

11126 6' PICNIC TABLE W/ UNATTACHED BENCHES ASSEMBLY INSTRUCTIONS

TOOLS NEEDED:

Drill with #2 Phillips Bit,
1/4" and 3/32" Drill Bits
2 - 7/16" Wrenches or Sockets
File

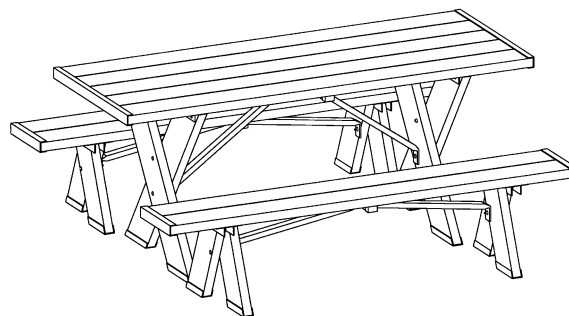

TABLE ASSEMBLY

TABLETOP ASSEMBLY

(Refer to Drawing 1)

On a flat, non-abrasive surface lay out the four tabletop rails and one middle tabletop rail found in Box 1 as shown on page 3. Set the four table brackets over pilot holes, making sure brackets are offset as shown. Fasten brackets to tabletop rails using 3/4" screws. Apply glue to the inside edges of the 7/8 x 1 1/2" molded end caps and push onto the ends of tabletop center brace. Lay the brace over pilot holes in center of tabletop rails and fasten using 1.5" Screws. Apply glue to the inside edges of the 7/8 x 1 1/2 x 28" end caps and push onto the ends of tabletop assembly, make sure edges are flush. **Do not slide end caps on from ends of tabletop.**

LEG ATTACHMENT AND TABLE FINISHING

(Refer to Drawing 2) (Make 2)

Loosely bolt two legs together, using 3 1/2" bolts, washers and nylock nuts (make sure pilot holes for brackets are at the same end).

Place one set of legs into the bracket slots; line up pilot holes and fasten legs to tabletop using 2 1/4" bolts, washers and nylock nuts as shown. Repeat for opposite side.

Remove bottom nylock nut on one leg and slide bolt through the hole on diagonal brace, replace nut and tighten snugly. Repeat for opposite side. Overlap the two diagonal braces in the center of table, drill two 3/32" pilot holes through the diagonal braces and into center brace. Fasten with 1.5" screws to the center tabletop brace.

Apply glue to the inside edges of the 7/8 x 1 1/2 x 7 1/4" angled end caps and push onto the bottoms of each table leg.

BENCH ASSEMBLY

SEAT ASSEMBLY

(Refer to Drawing 3) (Make 2)

Lay out two of the bench rails found in Box 2 as shown, leaving a 1/8" gap between rails. Set the two brackets over pilot holes and fasten brackets to bench rails using 3/4" screws. Apply glue to the 7/8 x 1 1/2" molded end caps and push onto ends of center bench brace. Lay the brace over the pilot holes in center of rails and fasten using 1.5" screws.

LEG ATTACHMENT AND FINISHING

(Refer to Bench Drawing 4)

Set one of the bench legs with pilot holes into bracket as shown, place a second leg on the inside of the bracket and loosely fasten bracket with 4" bolts, washers and nylock nuts. Set the angled bench brace in place on inside of legs, slide two washers in between legs and fasten with 4" bolt, washers and nylock nuts.

Repeat for opposite end of bench.

Join the diagonal bench braces, so they are overlapping in center, drill two 3/32" holes through the diagonal braces and into the center brace. Fasten using 1.5" screws.

Apply glue to the 7/8 x 1 1/2 x 11 1/8" end caps and push onto both ends of bench.

Tighten all bolts snugly. Apply glue to the eight 7 1/4" angled end caps and push onto the bottom of each leg.

Upon completion of table be sure to file or sand any sharp edges on the end caps to prevent cuts and scrapes.

If you encounter missing or defective parts, please contact manufacturer direct at toll free # below.

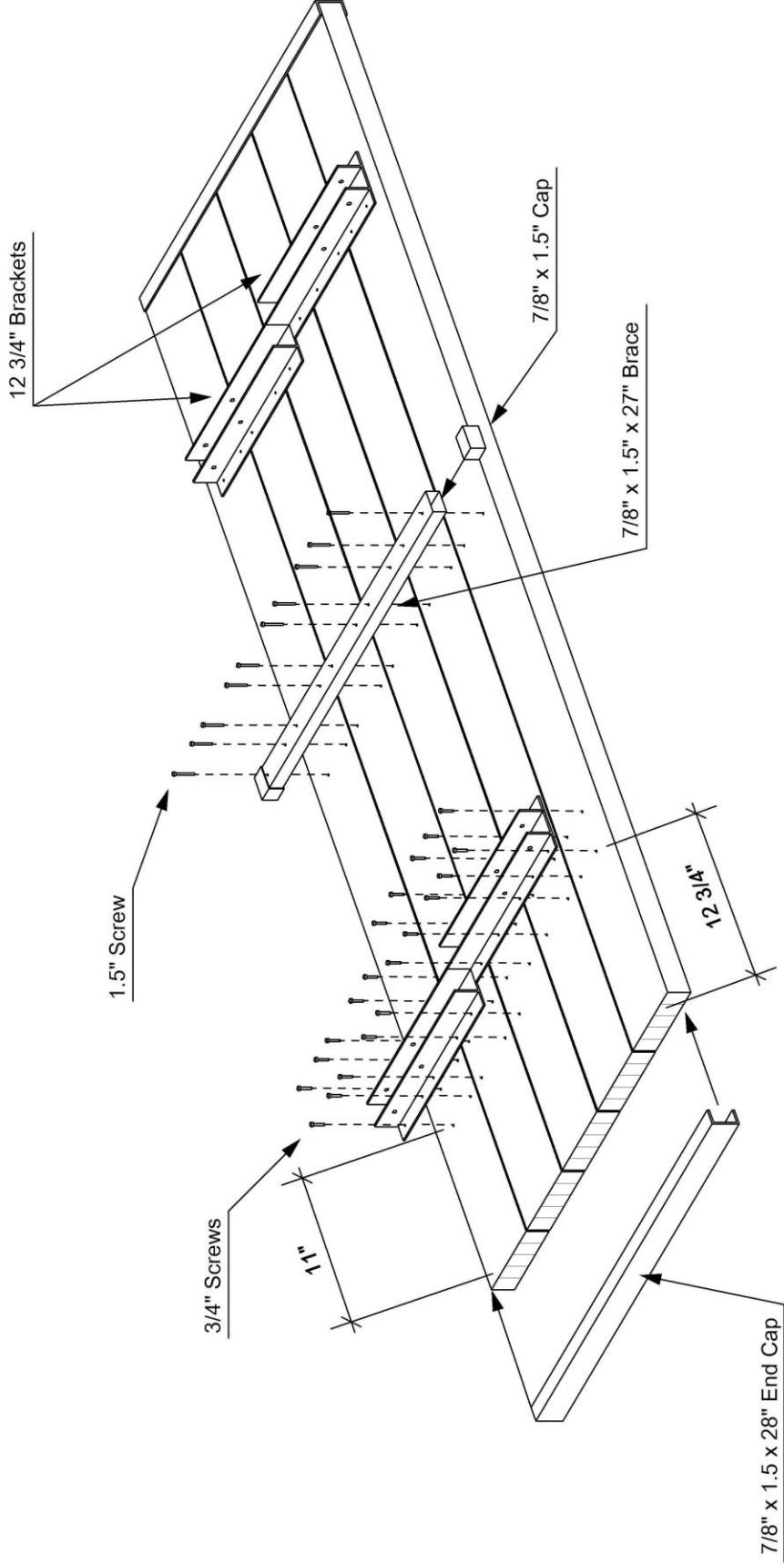

When laying out planks for table, be sure to use 5 planks from Box 1. The planks in Box 1 have holes that are not evenly spaced from each end. Lay out the planks as seen above.

Dura-Trel, Inc.

P.O. Box 122, Sheboygan Falls, WI 53085

6' Table with Benches Drawing 1

Scale: 1'-0" = 1"	Date: 8-27-99	Drawn By: RJS III
-------------------	---------------	-------------------

7/8" x 1.5" x 7 1/4" Leg End Caps

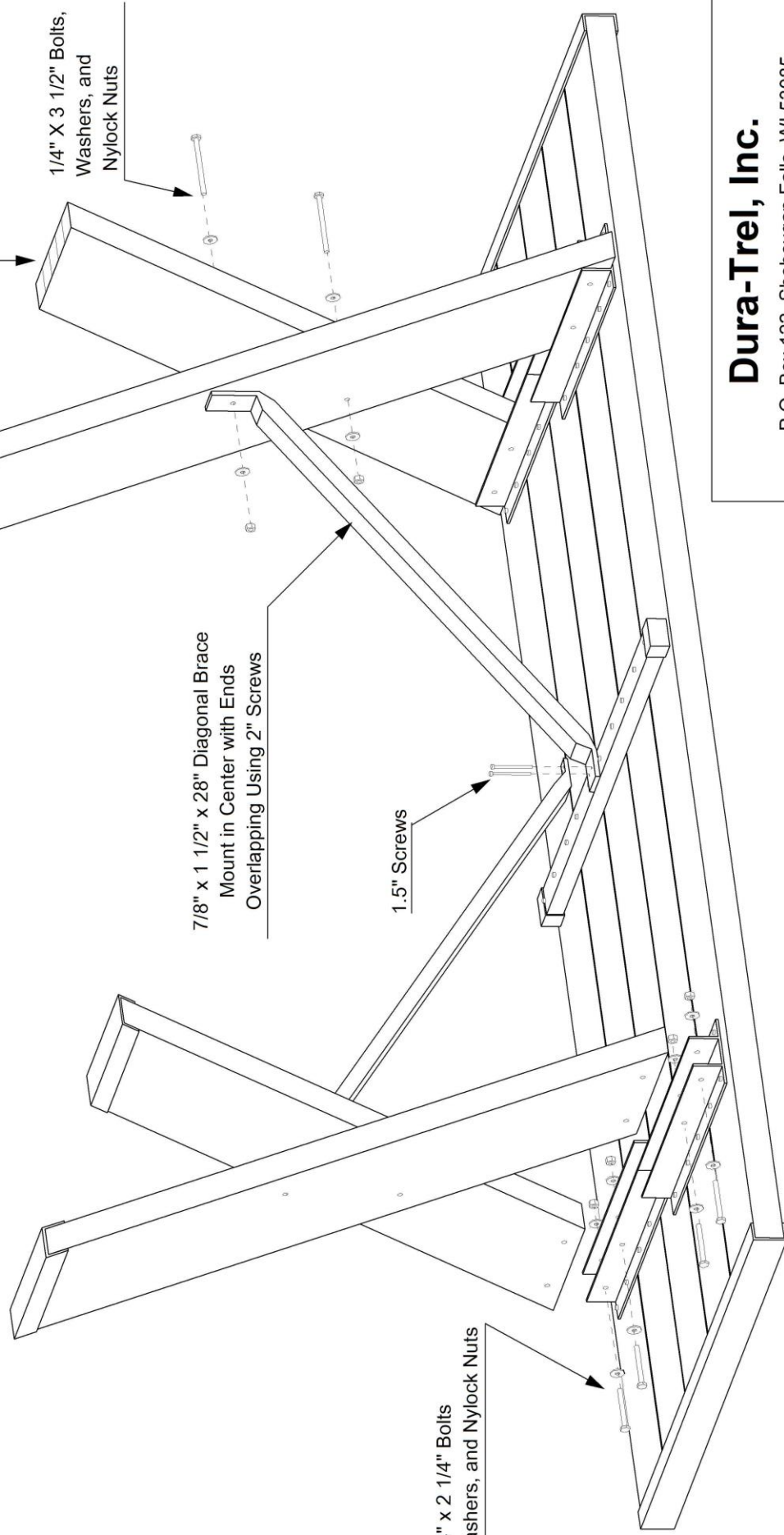

Dura-Trel, Inc.

P.O. Box 122, Sheboygan Falls, WI 53085

6' Table with Benches Drawing 2

Scale: 1'-0" = 1 1/2" Date: 8-27-99 Drawn by: RJS III

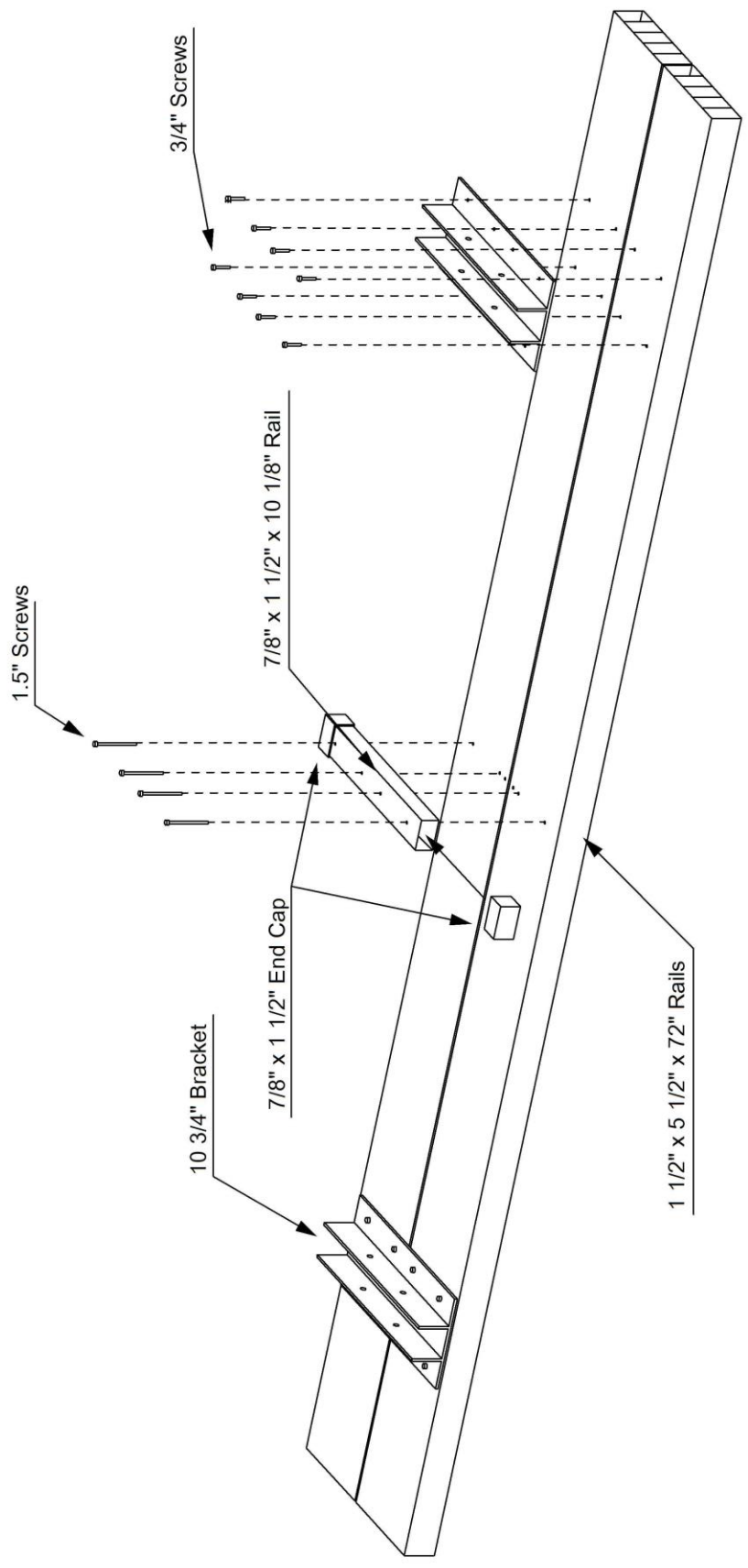

Dura-Trel, Inc.

P.O. Box 122, Sheboygan Falls, WI 53085

**6' Table with Benches
Drawing 3**

Scale: 1'-0" = 1 1/2"	Date: 4-21-02	Drawn by: RJS III
-----------------------	---------------	-------------------

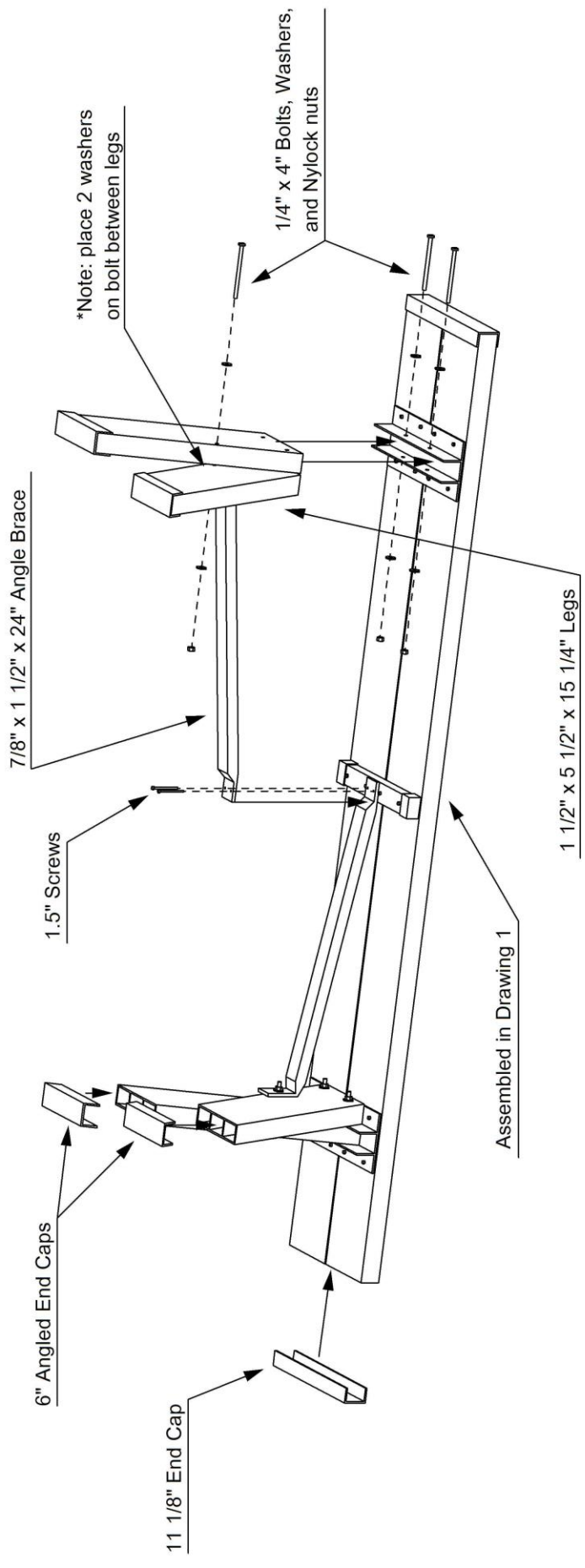

Dura-Trel, Inc.

P.O. Box 122, Sheboygan Falls, WI 53085

6' Table with Benches Drawing 4

Scale: 1'-0" = 1"

Date: 4-21-02

Drawn By: RJS III



PACKING LIST

#11126 6' Table w/ Benches

PARTS CONTAINED:

QTY.	PART #	PART DESCRIPTION	BOX#
4	41555-72002	1½ x 5½ x 72" TABLE RAIL	1
1	41555-72003W	1½ x 5½ x 72" CENTER TABLE RAIL	1
		Inner Box Includes:	1
4	4TBCK-12750	12¾" TABLE BRACKET	
4	4TBCK-10250	10¼" BENCH BRACKET	
1	47815-27000	7⁄8 x 1½ x 27" TABLE CROSS BRACE	
2	47815-10250	7⁄8 x 1½ x 10¼" BENCH CROSS BRACE	
2	57815-26500	7⁄8 x 1½ x 26½" TABLE ANGLE BRACE	
4	57815-24750	7⁄8 x 1½ x 24¾" BENCH ANGLE BRACE	
2	5ECAP-28000	7⁄8 x 1½ x 28" TABLE END CAP	
4	5ECAP-11180	7⁄8 x 1½ x 11½" BENCH END CAP	
4	5ECAP-07250	7⁄8 x 1½ x 7¼" TABLE LEG END CAP	
8	5ECAP-06000	7⁄8 x 1½ x 6" BENCH LEG END CAP	
		Hardware Bag Includes:	1
6	7CAPS-7815E	7⁄8 x 1½" END CAP	
72	7HDWR-06034	¾" SCREW	
24	7HDWR-06200	1½" SCREW	
8	7HDWR-14225	¼ x 2¼" BOLT	
4	7HDWR-14350	¼ x 3½" BOLT	
12	7HDWR-14400	¼ x 4" BOLT	
52	7HDWR-14WSH	¼" WASHER	
24	7HDWR-14NUT	¼" NYLOCK NUT	
2	7GLUE-4OZCN	Super Glue Tube	
4	41555-72004	W 1½ x 5½ x 72" BENCH RAIL	2
4	41555-34000	W 1½ x 5½ x 34" TABLE LEG	2
8	41555-15750	1½ x 5½ x 15¾" BENCH LEG	2

NOTE: Some parts may be packed inside of others.

If you encounter missing or defective parts, please contact manufacturer direct at toll free # below.