

REVISIONS

REV.	DESCRIPTION	DATE
AC	Removed Welding Operations	1/25/06
AD	Added 2" to tray	8/07/06
AE	Changed to .875 Bearing	8/21/07
AF	Changed to 1.0325 slot, changed tray sides, added rear rubber stops	7/23/12
AG	Moved front guide bearing hole back 2"	7/18/13
AH	Moved .265x.500 slot in tray stfmr to 1.125 from 1.0625	9/30/13
AI	Update to handle under tray	1/10/17

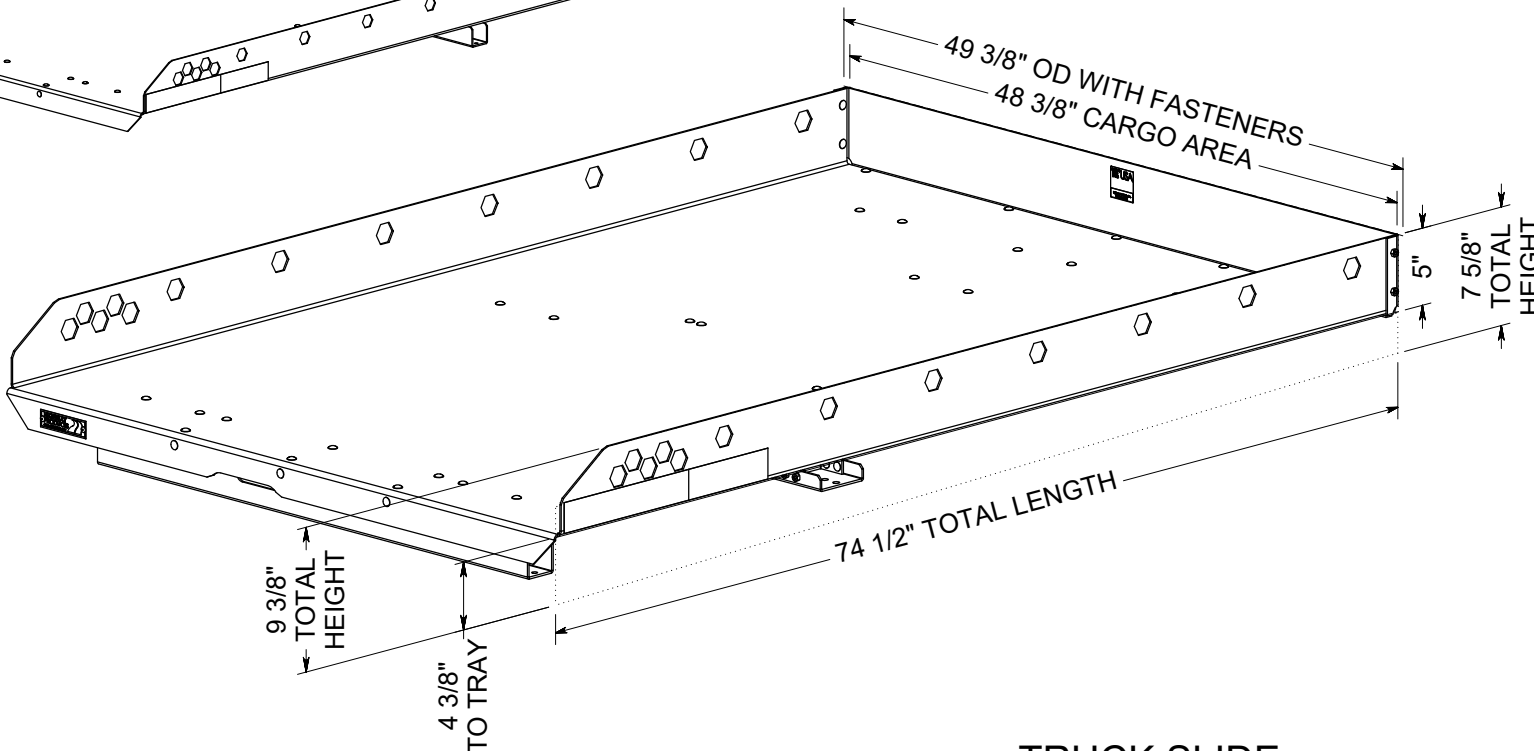
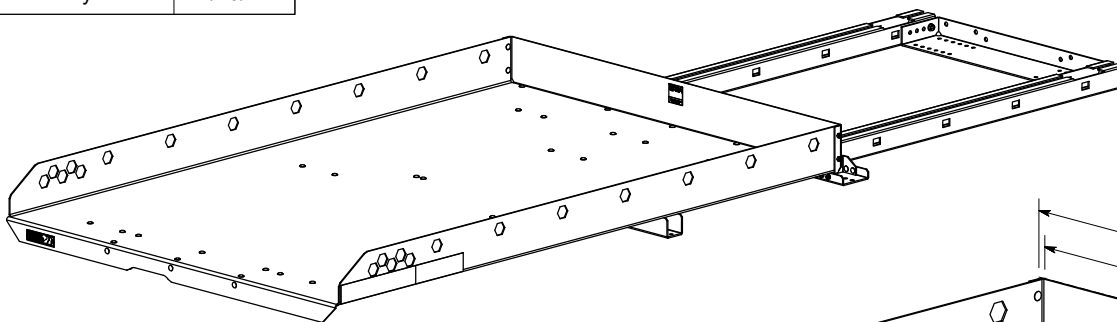
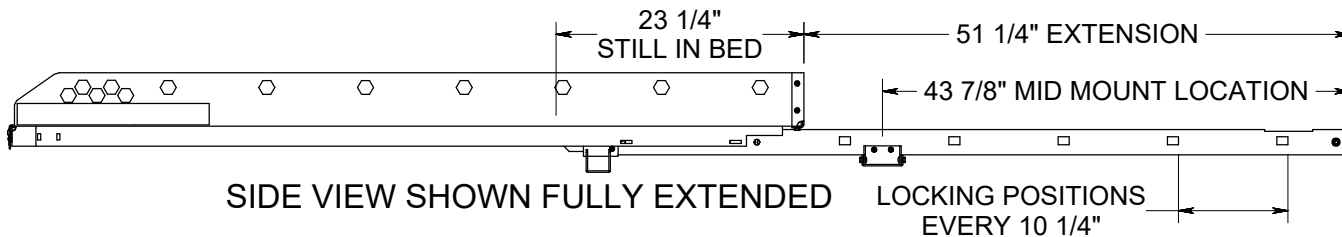

PC LX FI

CUSTOMER:

APPROVAL SIGNATURE _____

YOUR PRODUCTION LEAD TIME WILL BEGIN AS SOON AS WE RECEIVE YOUR SIGNATURE APPROVAL ON THE PRINTS WITHOUT ANY REQUESTS FOR CHANGES. THANK YOU.

CUSTOMER SPECIAL INSTRUCTIONS:

MATERIAL: AL & 10ga GALV		PROJECT #: 491
FINISH: SMOOTH		DRAWN BY: Sheldon Bywater
REVISION: AI	APVL BY: EBF	ENG DATE: 11/11/2016
Ov1	SALE BY:	TOLERANCES: ANGULAR $\pm 2^\circ$ FRACTIONAL $\pm 3/16"$ TWO PLACE DECIMAL $\pm .125$ THREE PLACE DECIMAL $\pm .0625$

SPECIAL INSTRUCTIONS:

**TRUCK SLIDE
OVERALL DIMENSIONS
49 3/8" x 9 3/8" x 74 1/2"**

HIGHWAY PRODUCTS
1-800-TOOL BOX
FAX 1-800-465-9545
800TOOLBOX.COM

