



Food Waste Disposers

STANDARD SERIES

Badger® 500



Submittal Sheet

This popular model offers the following features and benefits:

- 1/2 Horsepower Heavy Duty Motor (Quiet Dura-Drive® Induction Motor)
- *We Come To You*® 3-Year In-Home Limited Warranty
- Rugged Galvanized Steel Construction (For Disposer Durability)
- Space-Saving Compact Design

Specifications

| | |
|-----------------------------|---|
| Type of Feed | Continuous |
| On/Off Control | Wall Switch |
| Motor | Single Phase |
| HP | 1/2 |
| Volts | 120 |
| HZ | 60 |
| RPM | 1725 |
| Amp. (Avg. Load) | 6.3 |
| Time Rating | Intermittent |
| Lubrication | Permanently Lubricated Upper & Lower Bearings |
| Shipping Weight (Approx.) | 13 lbs. 10 oz. |
| Unit Finish | Waterborne Grey Enamel |
| Overall Height | 11-1/2" |
| Grind Chamber Capacity | 26 oz. |
| Motor Protection | Manual Reset Overload |
| Average Water Usage | Approx. 1 Gallon per Person Per Day |
| Average Electrical Usage | 3-4 kWh per Year |
| Drain Connection | 1-1/2" Cushioned Slip Joint |
| Dishwasher Drain Connection | Yes |

Dimensions

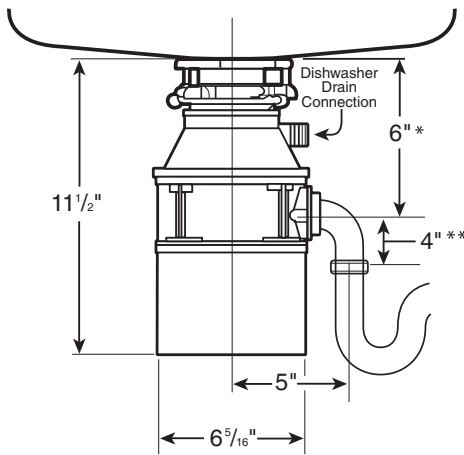

* Distance from bottom of sink to center line of disposer outlet. Add 1/2" when stainless steel sinks are used.

** Length of tailpipe from center line of disposer outlet to end of tailpipe. NOTE: Plumb waste line to prevent standing water in disposer motor housing.

Sample Specification

Food Waste Disposer(s) shall be InSinkErator Badger® 500, continuous feed, with 1/2 H.P. motor, galvanized steel grinding elements with two Stainless Steel 360° swivel lugs. Self-service wrench.

Limited Warranty:
3-Year parts and in-home service.

* The complete InSinkErator warranty is included in the Care & Use Booklet packed with each unit.



Food waste is roughly 80% water. By using your disposal regularly, you can help divert food waste from landfills and reduce greenhouse gas emissions. Make sustainability a family affair by using your disposal. After all, the smallest changes can make the biggest impact.

Job Specifications



The Emerson logo is a trademark and service mark of Emerson Electric Co. The mounting collar configuration is a trademark of Emerson Electric Co.

InSinkErator may make improvements and/or changes in the specifications at any time, in its sole discretion, without notice or obligation and further reserves the right to change or discontinue models.

1-800-558-5700
www.insinkerator.com



Food Waste Disposers

Accessories

STS-OOSN

SinkTop Switch™ Dual Outlet

Convenient Alternative to a Wall Switch.

The stylish SinkTop Switch is air-activated and easily mounts to the sink or countertop. It is perfect for island installations and works with any disposer.



Submittal Sheet

- Air-activated
- Mounts easily to sink or countertop
- Available in dual and single-outlet design
- For use with all InSinkErator disposers
- The unique dual-outlet design makes it a great power source for a hot water dispenser
- Finishes available to match most decors
- **Available in these designer finishes:** Satin Nickel, Chrome*, White*, Gloss Black*, Biscuit*, Mocha Bronze*, Oil-Rubbed Bronze*, Matte Black*, French Gold*, Brushed Bronze*, Classic Oil-Rubbed Bronze*, and Polished Nickel* (*Special Order Finish)

Specifications

| | |
|------------------------|---|
| Kit Includes: | <ul style="list-style-type: none"> • Power module with cord • 6-foot-long air tube • Button: Satin Nickel • Mounting Hardware: 2 1" #8 screws and 2 anchors |
| Power Cord Length | 33" |
| Required Hole Diameter | 1-1/4" |
| Counter Thickness | 2" |

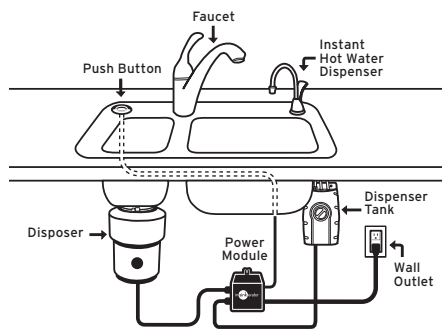

Warranty:

One Year over-the-counter replacement warranty.

Dimensions

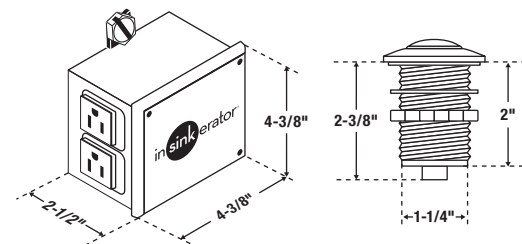

Job Specifications

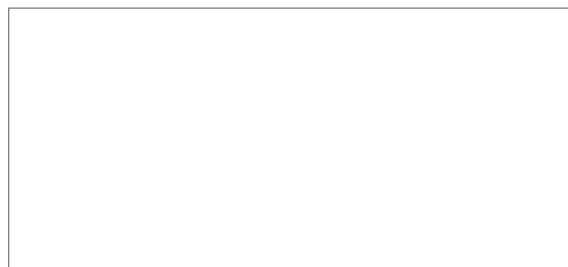

USA
1-800-558-5700
www.insinkerator.com

Canada
1-800-558-5700
www.insinkerator.ca

InSinkErator may make improvements and/or changes in the specifications at any time, in its sole discretion, without notice or obligation and further reserves the right to change or discontinue models.

© 2018 InSinkErator, InSinkErator® is a business unit of Emerson Electric Co. All Rights Reserved.