



# SERVICE PARTS LIST

**BULLETIN NO.**  
**54-40-2770**

SPECIFY CATALOG NO. AND SERIAL NO. WHEN ORDERING PARTS		REVISED BULLETIN	DATE
<b>M18™ FUEL™ 16" Chain Saw</b>			Aug. 2019
CATALOG NO.	<b>2727-20</b>	STARTING SERIAL NO.	<b>J36A</b>
		WIRING INSTRUCTION <b>SEE PAGE 4</b>	

**EXAMPLE:**  
Component Parts (Small #) Are Included  
When Ordering The Assembly (Large #).

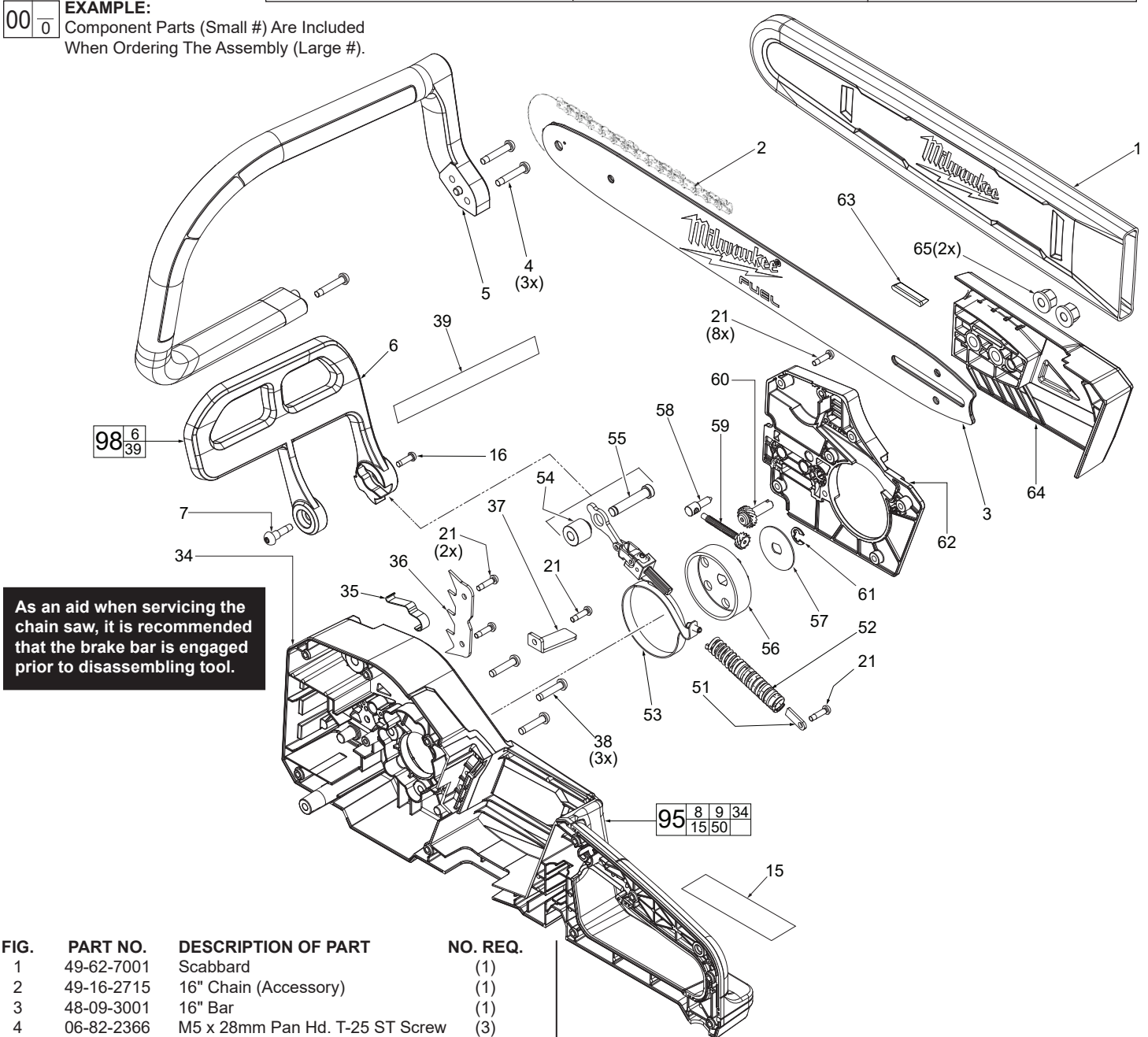

As an aid when servicing the chain saw, it is recommended that the brake bar is engaged prior to disassembling tool.

FIG.	PART NO.	DESCRIPTION OF PART	NO. REQ.
1	49-62-7001	Scabbard	(1)
2	49-16-2715	16" Chain (Accessory)	(1)
3	48-09-3001	16" Bar	(1)
4	06-82-2366	M5 x 28mm Pan Hd. T-25 ST Screw	(3)
5	43-62-9001	Bail Handle	(1)
6	-----	Brake Bar	(1)
7	06-82-4010	M5 x 21mm Pan Hd. ST T-25 Screw	(1)
15	10-20-2078	Spanish/French Warning Label	(1)
16	05-88-1210	M4 x 14mm Pan Hd. T-20 Mach. Screw	(1)
21	05-88-1200	M4 x 16mm Pan Hd. ST T-20 Screw	(14)
34	-----	Handle Support	(1)
35	42-36-1001	Hand Brake Tension Spring	(1)
36	43-72-3001	Spur Bracket	(1)
37	42-36-9001	Chain Catcher	(1)
38	06-82-3001	M5 x 24mm Pan Hd. T-25 Mach. Screw	(3)
39	10-20-2077	Icon Warning Label	(1)
51	44-66-7001	Brake Spring Support Plate	(1)
52	40-50-7111	Brake Spring	(1)
53	14-04-0110	Brake Assembly	(1)
54	42-40-3001	Bushing	(1)
55	44-94-7001	Brake Shaft	(1)
56	45-44-4002	Sprocket	(1)

FIG.	PART NO.	DESCRIPTION OF PART	NO. REQ.
57	45-88-7001	Chain Washer	(1)
58	05-89-2001	Chain Tensioning Post	(1)
59	05-89-8001	Chain Tensioner Main Screw	(1)
60	05-81-9001	Chain Tensioner Adjustment Screw	(1)
61	42-70-5268	Retaining E-Ring	(1)
62	42-92-5001	Chain Brake Cover	(1)
63	43-84-1001	Insert Block	(1)
64	43-72-9002	Bar Holder	(1)
65	05-55-5001	13mm M8 Flange Nut	(2)
95	14-34-0220	Handle Kit	(1)
98	42-18-7001	Brake Bar Assembly	(1)

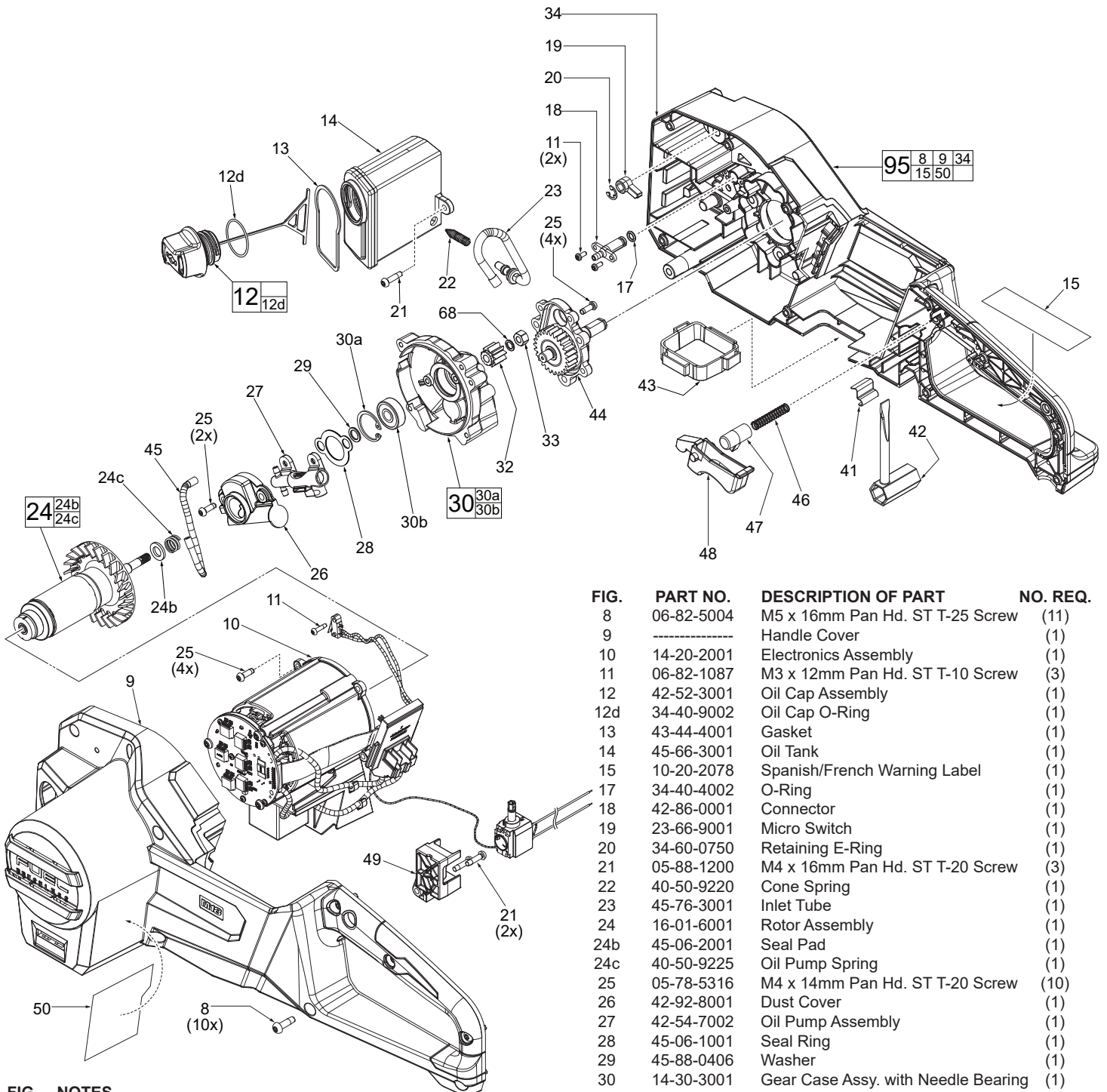

FIG.	PART NO.	DESCRIPTION OF PART	NO. REQ.
8	06-82-5004	M5 x 16mm Pan Hd. ST T-25 Screw	(11)
9	-----	Handle Cover	(1)
10	14-20-2001	Electronics Assembly	(1)
11	06-82-1087	M3 x 12mm Pan Hd. ST T-10 Screw	(3)
12	42-52-3001	Oil Cap Assembly	(1)
12d	34-40-9002	Oil Cap O-Ring	(1)
13	43-44-4001	Gasket	(1)
14	45-66-3001	Oil Tank	(1)
15	10-20-2078	Spanish/French Warning Label	(1)
17	34-40-4002	O-Ring	(1)
18	42-86-0001	Connector	(1)
19	23-66-9001	Micro Switch	(1)
20	34-60-0750	Retaining E-Ring	(1)
21	05-88-1200	M4 x 16mm Pan Hd. ST T-20 Screw	(3)
22	40-50-9220	Cone Spring	(1)
23	45-76-3001	Inlet Tube	(1)
24	16-01-6001	Rotor Assembly	(1)
24b	45-06-2001	Seal Pad	(1)
24c	40-50-9225	Oil Pump Spring	(1)
25	05-78-5316	M4 x 14mm Pan Hd. ST T-20 Screw	(10)
26	42-92-8001	Dust Cover	(1)
27	42-54-7002	Oil Pump Assembly	(1)
28	45-06-1001	Seal Ring	(1)
29	45-88-0406	Washer	(1)
30	14-30-3001	Gear Case Assy. with Needle Bearing	(1)
30a	34-40-0029	Retaining Ring	(1)
30b	02-04-0001	Ball Bearing	(1)
32	32-60-3002	Spur Pinion	(1)
33	05-55-1001	M6 Hex Nut	(1)
34	-----	Handle Support	(1)
41	44-66-9001	Wrench Catcher	(1)
42	45-96-1001	Wrench	(1)
43	42-92-3001	Wire Cover	(1)
44	14-73-7001	Spindle/Gear Assembly	(1)
45	45-76-2001	Outlet Tube	(1)
46	40-50-6010	Switch Spring	(1)
47	42-42-4001	Lock Off Button	(1)
48	45-72-3001	Trigger	(1)
49	45-60-9001	Switch Support	(1)
50	12-20-2727	Service Nameplate	(1)
68	45-88-0506	Washer	(1)
95	14-34-0220	Handle Kit	(1)

**FIG. NOTES**

- 24 Great care must be used when removing or installing rotor assembly. Magnet on rear end of rotor is very fragile.
- 33 Torque hex nut to 100kg.cm±3 (87in.lbs±2).
- 95 Prior to taking tool apart, use a sharp razor blade to score the center line of nameplate (33) and symbol labels (36 and 37). This will allow housing halves (15 and 29) to separate when housing screws are removed.
- 15,39,50 A clean, dry surface is essential for proper performance for any adhesive system. The area intended for application of any adhesive label or nameplate must be prepared by cleaning with isopropyl alcohol. The solvent is to be applied with a clean, lint free applicator and the surface allowed to dry before applying any label or nameplate.

**LUBRICATION:**

● = Type 'J' Grease, 49-08-4220 (1 lb. can)

● = 243 Blue Loctite, 44-22-0095

**When servicing, remove 90-95% of the existing grease prior to installing Type 'J'. Original grease maybe similar in color but not compatible with 'J'.**

**NOTE**  
Regarding parts to receive thread locking sealant:  
Place one to two drops of the recommended Loctite® thread locking sealant (or the equivalent) to the threads of parts shown prior to installation.

**NOTE**  
Regarding parts to be lubricated:  
Apply a light coating of grease to all highlighted parts shown prior to installation. Reference the key above for grease types.

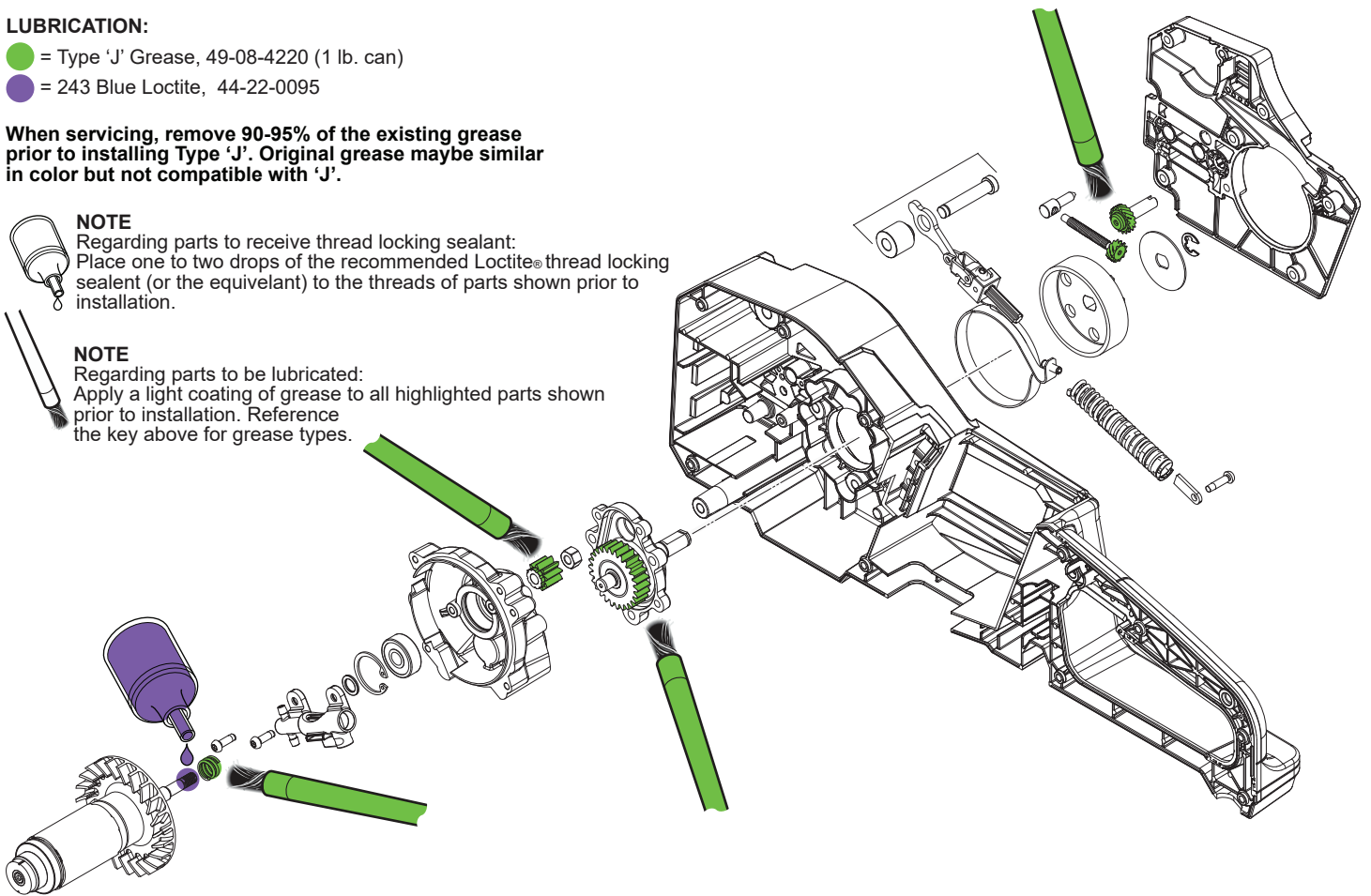

**SCREW TORQUE SPECIFICATIONS**

FIG.	PART NO.	WHERE USED	SEAT TORQUE	
			(KG/CM)	(IN/LBS)
4	06-82-2366	Bail Handle	24±3	20±3
7	06-82-4010	Brake Bar (left side)	15±2	13±2
8	06-82-5004	Handle Cover	26±3	22±3
11	06-82-1087	Connector	5.5±0.5	4±0.5
11	06-82-1087	Micro Switch	5.5±0.5	4±0.5
16	05-88-1210	Brake Bar (right side)	10±1	8±1
21	05-88-1200	Spur Bracket	15±2	13±2
21	05-88-1200	Switch Support	15±2	13±2
21	05-88-1200	Oil Tank	15±2	13±2
25	05-78-5316	Electronics Assembly	15±2	13±2
25	05-78-5316	Dust Cover	15±2	13±2
25	05-78-5316	Spindle/Gear Assembly	15±2	13±2
33	05-55-1001	Rotor Assembly	100±3	86±3
38	06-82-3001	Handle Support	33±3	28±3
65	05-55-5001	Bar Holder	26±3	22±3

- |   |       |                            |    |       |                         |
|---|-------|----------------------------|----|-------|-------------------------|
| 1 | Red   | Micro Switch/Control Board | 10 | Black | Terminal/SSD Board      |
| 2 | Green | Micro Switch/Control Board | 11 | Red   | Terminal/SSD Board      |
| 3 | Black | Gearcase/Control Board     | 12 | Red   | SSD Board/Power Board   |
| 4 | White | Ribbon Cable               | 13 | Blue  | SSD Board/Control Board |
|   |       | Control Board/Power Board  | 14 | Green | SSD Board/Control Board |
| 5 | Red   | Switch/Control Board       | 15 | Black | SSD Board/Control Board |
| 6 | Black | Switch/Control Board       |    |       |                         |
| 7 | White | Switch/Control Board       |    |       |                         |
| 8 | White | Switch/Control Board       |    |       |                         |
| 9 | White | Switch/Control Board       |    |       |                         |

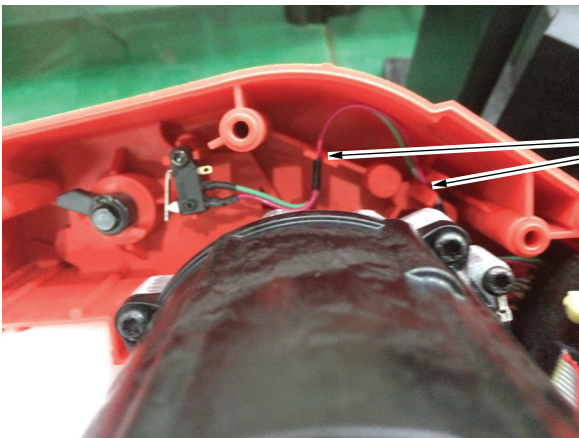
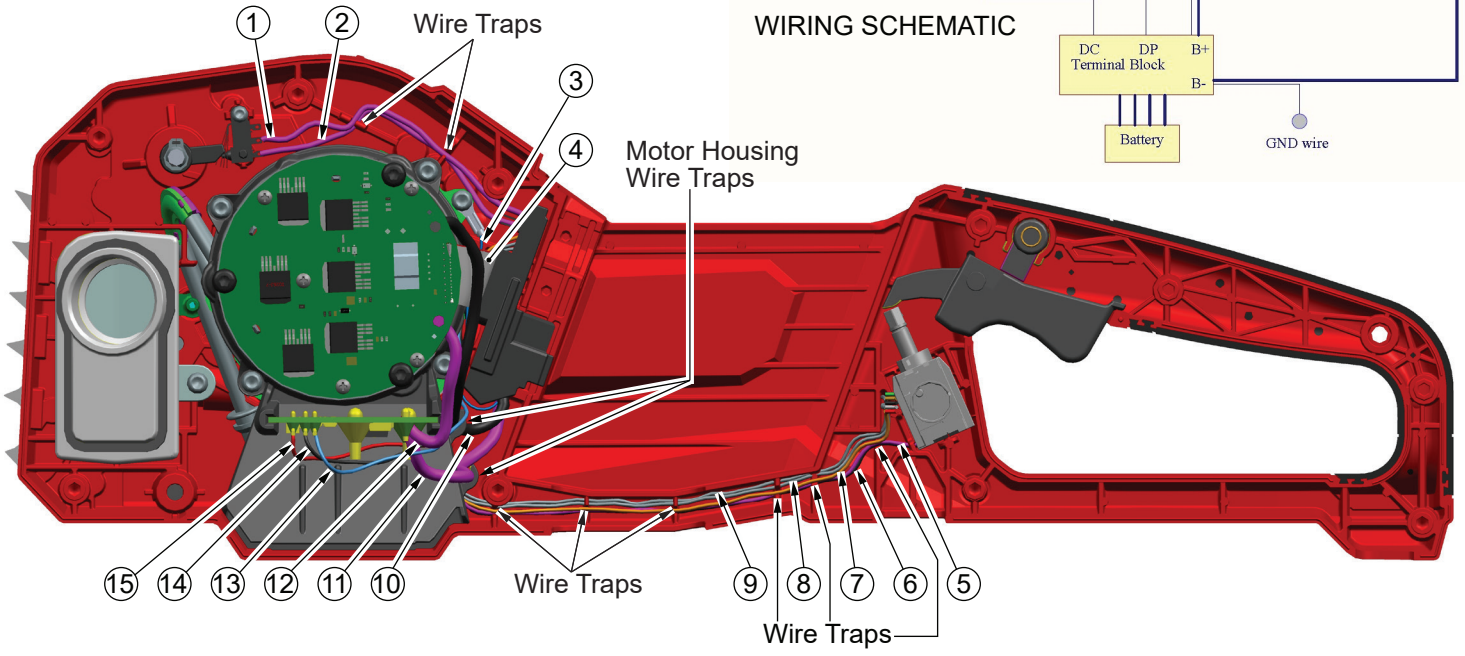
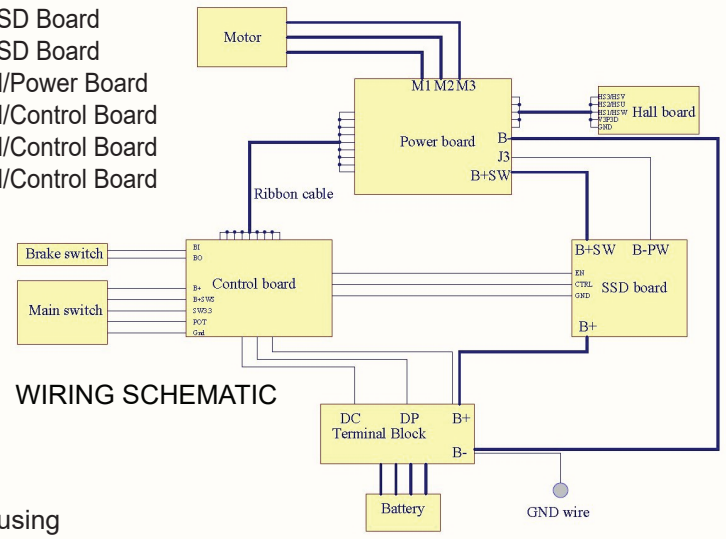

Place wires #1 and #2 completely in bottom of wire traps.

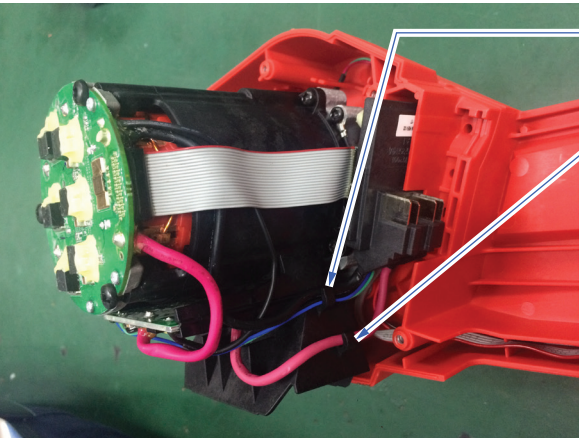

Place wires #10, #13, #14 and #15 in motor housing wire trap.

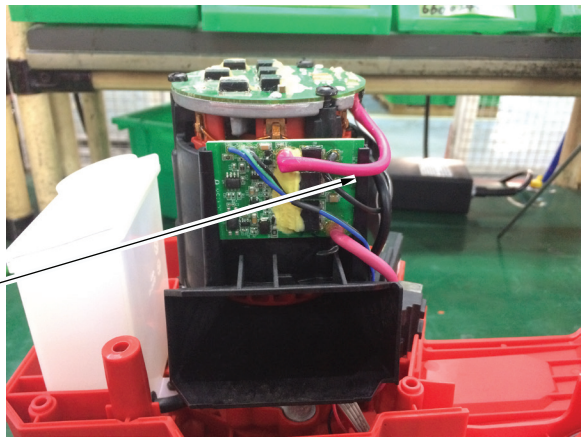

Route red wire #6 in wire trap of motor housing.

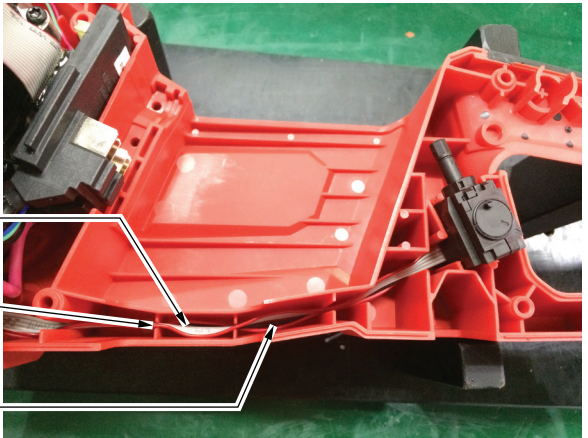

Place #11 red wire in motor housing wire trap.

Place ribbon cable in top of traps.

Place red wire #11 in the middle of traps.

Place black wire #12 in bottom of wire traps.