

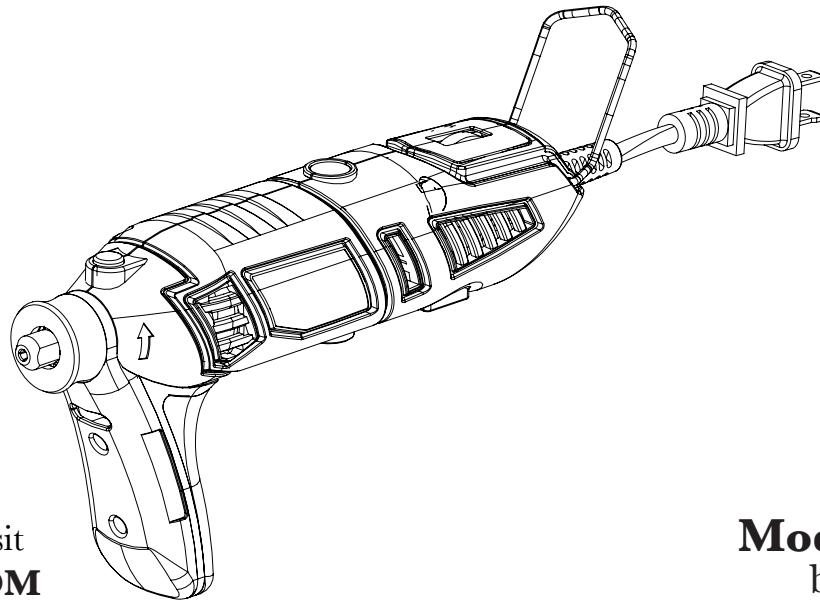

VARIABLE SPEED ROTARY TOOL KIT



Intertek
3065544

For replacement parts visit
WENPRODUCTS.COM

Model # 23190
bit.ly/wenvideo

IMPORTANT:

Your new tool has been engineered and manufactured to WEN's highest standards for dependability, ease of operation, and operator safety. When properly cared for, this product will supply you years of rugged, trouble-free performance. Pay close attention to the rules for safe operation, warnings, and cautions. If you use your tool properly and for its intended purpose, you will enjoy years of safe, reliable service.



NEED HELP? CONTACT US!

Have product questions? Need technical support?
Please feel free to contact us at:

 **800-232-1195** (M-F 8AM-5PM CST)

 techsupport@wenproducts.com

 **WENPRODUCTS.COM**

NOTICE: Please refer to wenproducts.com for the most up-to-date instruction manual.

TABLE OF CONTENTS

Product Specifications	2
Safety Introduction	3
General Safety Rules	4
Rotary Tool Safety Rules	6
Electrical Information	8
Know Your Rotary Tool	9
Know Your Accessories	10
Assembly & Adjustments	14
Operation	15
Maintenance	16
Warranty Statement	17
Exploded View & Parts List	18

PRODUCT SPECIFICATIONS

Model Number:	23190
Motor:	120V, 60 Hz, 1.3A
Speed:	8,000 to 35,000 RPM
Collet Sizes:	1/8", 3/32" & 1/16" (1.6 mm, 2.3 mm and 3.2 mm)
Product Weight:	1.5 lbs

Compatible Rotary Tool Accessories Kits:

150-Piece (Model 230151A), 282-Piece (Model 230282A),
320-Piece (Model 230321A), 327-Piece (Model 230327A).

Your rotary tool is also compatible with the WEN 2305-KC
Keyless Rotary Tool Chuck, available at wenproducts.com.

SAFETY INTRODUCTION

Thanks for purchasing the WEN Rotary Tool Kit. This is an exciting moment. You have received your new tool, opened the box, and are now about to read through the instruction manual. This manual provides information regarding potential safety concerns, as well as helpful assembly and operating instructions. Safe operation of this tool requires that you read and understand this operator's manual and all labels affixed to the tool.



SAFETY ALERT SYMBOL: Indicates danger, warning, or caution. The safety symbols and the explanations with them deserve your careful attention and understanding. Always follow the safety precautions to reduce the risk of fire, electric shock and personal injury. However, please note that these instructions and warnings are not substitutes for proper accident prevention measures.

NOTE: The following safety information is not meant to cover all possible conditions and situations that may occur. WEN reserves the right to change this product and specifications at any time without prior notice.

Keep this manual available to all users during the entire life of the tool and review it frequently to maximize safety for both yourself and others.

GENERAL SAFETY RULES

Safety is a combination of common sense, staying alert and knowing how your item works.

SAVE THESE SAFETY INSTRUCTIONS.



WARNING! Read all safety warnings and all instructions. Failure to follow the warnings and instructions may result in electric shock, fire and serious injury. To avoid mistakes and serious injury, do not plug in your tool until the following steps have been read and understood.

WORK AREA SAFETY

1. Keep work area clean and well lit. Cluttered or dark areas invite accidents. Do not work on floor surfaces that are slippery with sawdust or wax. Keep the ground clear of tripping hazards.
2. Do not operate power tools in explosive atmospheres, such as in the presence of flammable liquids, gases or dust. Power tools create sparks which may ignite the dust or fumes.
3. Keep bystanders at a safe distance from the work area. Never allow children or pets near the tool.

ELECTRICAL SAFETY

1. Do not expose power tools to rain or wet conditions. Water entering a power tool will increase the risk of electric shock. Do not touch the power plug with wet hands.
2. Power tool plugs must match the outlet. Never modify the plug in any way. Modified plugs with non-matching outlets will increase the risk of electric shock.
3. Check all power supplies periodically. Do not use defective cords. Damaged or entangled cords increase the risk of electric shock.
4. Do not abuse the cord. Never use the cord for carrying, pulling or unplugging the power tool. Keep cord away from heat, oil, sharp edges or moving parts.

PERSONAL SAFETY

1. Stay alert. Watch what you are doing and use common sense when operating a power tool. Do not use a power tool while you are tired or under the influence of drugs, alcohol or medication. A moment of inattention while operating power tools may result in serious personal injury.
2. Do not wear loose clothing, gloves, neckties, or jewelry (rings, watches, etc.) when operating the tool. Inappropriate clothing and items can get caught in moving parts and draw you in. Always wear non-slip footwear and tie back long hair.
3. Use personal protective equipment. Always wear safety goggles at all times that comply with ANSI Z87.1. Use ear protection such as plugs or muffs during extended periods of operation. Wear work gloves to protect your hands. Wear a face mask or dust mask to fight the dust.
4. Keep proper footing and balance at all times and do not overreach when operating the power tool.



WARNING: Dust generated from certain materials can be hazardous to your health. Always operate the tool in a well-ventilated area and wear a dust mask. Use dust collection systems when processing wood and plastics. Dust extractors or dust bags must not be connected when processing metals.

GENERAL SAFETY RULES

POWER TOOL USE AND CARE

1. Avoid accidental start-ups. Make sure the power switch is in the OFF position before connecting the plug to a power source or carrying the tool.
2. Check power tool for damaged parts. Check for misalignment of moving parts, jamming, breakage, improper mounting, or any other conditions that may affect the tool's operation. Do not use the power tool if the switch does not turn ON/OFF. Any part that is damaged should be properly repaired or replaced before use.
3. Do not force the tool to do a job for which it was not designed. Always use the correct tool/accessory for the job and follow instructions to prevent a hazardous situation.
4. Never stand on the tool. Serious injury could occur if the tool is tipped over or if parts of the tool are unintentionally contacted.
5. Remove adjustment tools. Always make sure all adjustment tools or wrenches are removed from the tool before turning on the power tool.
6. Keep guards in place and in working order before operating the tool. All protection and safety devices must be in place after completing repair and maintenance procedures.
7. Never leave a running tool unattended. Do not leave the tool until it has come to a complete stop.

POWER TOOL MAINTENANCE

1. Always disconnect the power cord plug from the electrical outlet when making adjustments, changing parts, or storing power tools. Such preventive safety measures reduce the risk of starting the power tool accidentally.
2. Maintain power tools properly. Safely store power tools out of the reach of children. Always keep tools clean and in good working order. Follow instructions for lubricating and changing accessories.
3. Use only identical replacement parts. Use of any other part can cause personal injury and damage to the tool. Only have your power tool serviced by a qualified repair person.

CALIFORNIA PROPOSITION 65 WARNING

This product and some dust created by power sanding, sawing, grinding, drilling, and other construction activities may contain chemicals, including lead, known to the State of California to cause cancer, birth defects, or other reproductive harm. Wash hands after handling.

Some examples of these chemicals are:

- Lead from lead-based paints.
- Crystalline silica from bricks, cement, and other masonry products.
- Arsenic and chromium from chemically treated lumber.

Your risk from these exposures varies depending on how often you do this type of work. To reduce your exposure to these chemicals, work in a well-ventilated area with approved safety equipment such as dust masks specially designed to filter out microscopic particles.

ROTARY TOOL SAFETY RULES



WARNING: Read and understand all warnings, cautions and operating instructions before using this equipment. Failure to follow all instructions listed below may result in personal injury and tool damage.

1. WORK ENVIRONMENT

- Do not operate the tool in wet or damp conditions; doing so significantly increases the risk of electrical shock.
- Do not operate the tool in the presence of flammable liquids or gases.

2. TOOL INSPECTION

- Before operation, check the tool for any damage or missing parts. Do not use the tool if any part is missing or damaged. Do not use the tool if the power switch is faulty, the plug or cable is damaged, or the tool produces sparks, smoke, or unpleasant odors (you may smell brushes burning for a few minutes as the tool breaks in during the first use, that is okay).
- Make sure all adjustments are correct and all connections are tight.

3. ACCESSORIES INSPECTION

- The accessory must have a rated speed higher than or equal to 35,000 RPM (the maximum tool operating speed of your rotary tool), otherwise there is a risk of injury.
- The spindle size of the accessory must properly fit the tool's collet in order to be mounted securely.
- Before operation, inspect the accessories for any chips, cracks or excess wear. Do not use damaged accessories.

4. WORKPIECE INSPECTION

- Check the workpiece for any cracks, bumps, nails or obstructions before commencing operation.
- Do not cut any workpiece that exceeds the rotary tool or the rotary tool bit's operation capacity.
- Check the position of all electrical wiring and plumbing equipment when drilling into walls, floors or ceilings.

5. SECURING THE WORKPIECE

Use clamps to secure the workpiece whenever possible to prevent wobble, damage to the workpiece, and personal injury.

6. PERSONAL SAFETY

- Always use ANSI Z87.1-approved safety goggles, a dust mask and hearing protection when using the rotary tool.
- Always maintain a firm grip on the rotary tool by the insulated gripping surfaces only.

7. SETTING THE SPEED

Set the suitable speed for your operation, workpiece and accessory. Use slow speeds for some plastics and precious metals to prevent damaging the material. Use slow speeds (15,000 RPM or less) for all brushing applications using wire wheels and polishing operations using felt polishing accessories. Use higher speeds for drilling, carving, cutting, routing, shaping, cutting dadoes or rabbets in wood, metal and glass.

8. USING THE FLEX SHAFT

- Never cross the flex shaft over itself during operation.
- Do not bend the flex shaft near its connection to the rotary tool.
- Do not operate the flex shaft with a sharp bend. The recommended minimum radius for the flex shaft is 5 inches. Bending the shaft farther than this can generate excessive heat and damage the flex shaft. Make sure to lubricate the flex shaft inner coil every couple of hours of operation.

9. TURNING ON THE TOOL

Before turning on the rotary tool, ensure that it is completely clear of the workpiece. Let the tool reach full speed before making contact with the workpiece.

ROTARY TOOL SAFETY RULES

10. DURING OPERATION

- Do not apply excessive pressure to the tool or attempt to make an excessive depth of cut. Overstressing the tool may cause kickback and damage the tool and accessories.
- Use special care when working corners, sharp edges etc. Avoid bouncing and snagging the accessory.
- Never touch any moving parts of the tool by hand.
- Never press in the spindle lock button when the rotary tool is running.

11. TURNING OFF THE TOOL.

Clear the tool from the workpiece before switching off the tool. Wait for the rotary bit to come to a complete stop before setting the tool down.

12. MAKING ADJUSTMENTS

- Always turn off the machine and disconnect from the power source before making adjustments or changing attachments. Do not remove the attachment from the tool until it has completely stopped rotating.
- Do not touch the accessory attachment immediately after operation, as it may be very hot. Allow time for the accessory to cool and calm down before removing it.

REDUCING KICKBACK

Kickback is a sudden reaction to a pinched or snagged rotating wheel, backing pad, brush or any other accessory. Pinching or snagging causes rapid stalling of the rotating accessory which in turn causes the uncontrolled power tool to be jump toward or away from the operator, depending on direction of the wheel's movement at the point of pinching. Take proper safety prevention methods to reduce the risk of kickback:

- Maintain a firm grip on the power tool and position your body and arm to allow you to resist kickback forces. Always use the auxiliary handle for maximum control over kickback or torque reaction during start-up. The operator can control torque reactions or kickback forces, if proper precautions are taken.
- Never place your hand near the rotating accessory. Accessories may kick back over your hand.
- Do not position your body in the area where power tool will move if kickback occurs. Kickback will propel the tool in direction opposite to the wheel's movement at the point of snagging.
- Use special care when working corners, sharp edges etc. Avoid bouncing and snagging the accessory. Corners, sharp edges or bouncing have a tendency to snag the rotating accessory and cause loss of control or kickback.

VIBRATION SAFETY

This tool vibrates during use. Repeated or long-term exposure to vibration may cause temporary or permanent physical injury, particularly to the hands, arms and shoulders. To reduce the risk of any vibration-related injury:

- First be examined by a doctor and then have regular medical check-ups to ensure medical problems are not being caused or worsened from use. Pregnant women or people who have impaired blood circulation to the hand, past hand injuries, nervous system disorders, diabetes, or Raynaud's disease should not use this tool.
- If you feel any symptoms related to vibration (such as tingling, numbness, and white or blue fingers), seek medical advice as soon as possible.
- Take vibration-free breaks during each day of work.

ELECTRICAL INFORMATION

DOUBLE INSULATION

Double insulation is a concept in safety in electric power tools, where two systems of insulation are provided. This eliminates the need for the usual three-wire grounded power cord. All exposed metal parts are isolated from the internal metal motor components with protecting insulation. Double insulated tools do not need to be grounded, nor should a means for grounding be added to the product.

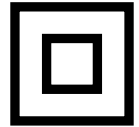

IMPORTANT: Servicing a double-insulated product requires extreme care and knowledge of the system, and should be done only by a qualified service personnel using identical replacement parts. Always use original factory replacement parts when servicing.

1. **POLARIZED PLUGS.** To reduce the risk of electric shock, this equipment has a polarized plug (one blade is wider than the other). This plug will fit in a polarized outlet only one way. If the plug does not fit fully in the outlet, reverse the plug. If it still does not fit, contact a qualified electrician to install a proper outlet. **DO NOT** modify the machine plug or the extension cord in any way.
2. **GROUND FAULT CIRCUIT INTERRUPTER PROTECTION (GFCI)** should be provided on the circuit or outlet used for this power tool to reduce the risk of electric shock.
3. **SERVICE AND REPAIR.** To avoid danger, electrical appliances must only be repaired by qualified service technician using original replacement parts.



WARNING: To avoid electrocution, do not use in wet or damp areas or expose to rain.

GUIDELINES FOR USING EXTENSION CORDS

When using an extension cord, be sure to use one heavy enough to carry the current your product will draw. An undersized cord will cause a drop in line voltage resulting in loss of power and overheating. The table below shows the correct size to be used according to cord length and nameplate ampere rating. When in doubt, use a heavier cord. The smaller the gauge number, the heavier the cord.

AMPERAGE	REQUIRED GAUGE FOR EXTENSION CORDS			
	25 ft.	50 ft.	100 ft.	150 ft.
1.3A	18 gauge	18 gauge	16 gauge	14 gauge

1. Examine extension cord before use. Make sure your extension cord is properly wired and in good condition. Always replace a damaged extension cord or have it repaired by a qualified person before using it.
2. Do not abuse extension cord. Do not pull on cord to disconnect from receptacle; always disconnect by pulling on plug. Disconnect the extension cord from the receptacle before disconnecting the product from the extension cord. Protect your extension cords from sharp objects, excessive heat and damp/wet areas.
3. Use a separate electrical circuit for your tool. This circuit must not be less than a 12-gauge wire and should be protected with a 15A time-delayed fuse. Before connecting the motor to the power line, make sure the switch is in the OFF position and the electric current is rated the same as the current stamped on the motor nameplate. Running at a lower voltage will damage the motor.

KNOW YOUR ROTARY TOOL

Carefully unpack the tool from the packaging. Check all components and compare against the diagram below. If any part is damaged or missing, please contact our customer service at (800) 232-1195, M-F 8-5 CST or email us at techsupport@wenproducts.com.

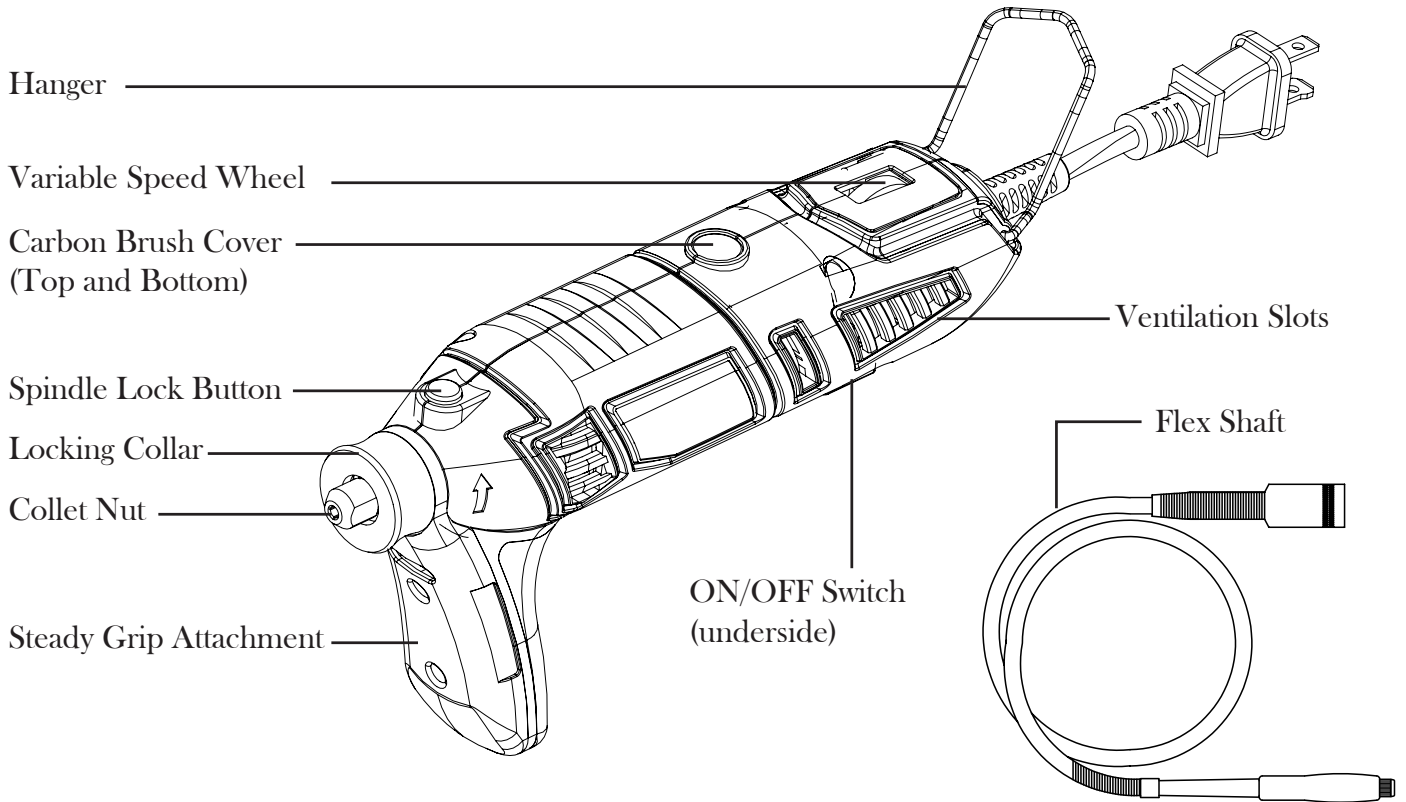

STEADY GRIP HANDLE ATTACHMENT (Fig. 1 & 2)

Your rotary tool can be used in two configurations, depending on your personal preference and the requirement of the project.

1. The tool comes assembled with the steady grip handle for extra control during operation.

2. Convert it to the regular configuration by unscrewing the locking collar (Fig. 1 - 1) and removing the steady grip attachment (Fig. 1 - 2). Find the wider locking collar included in your rotary tool kit, and thread it onto the end of the rotary tool (Fig. 2).

Hold the rotary tool in your hand to get a feel for this baby. For milling and engraving operations, holding the rotary tool like a pen will yield better control. For heavier work like drilling, holding the tool like a hammer will yield better results.

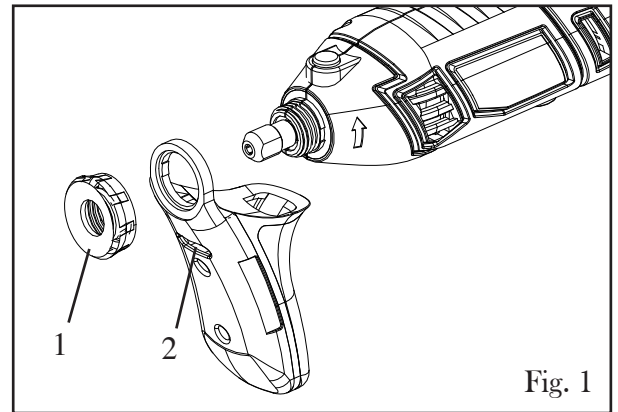

Fig. 1

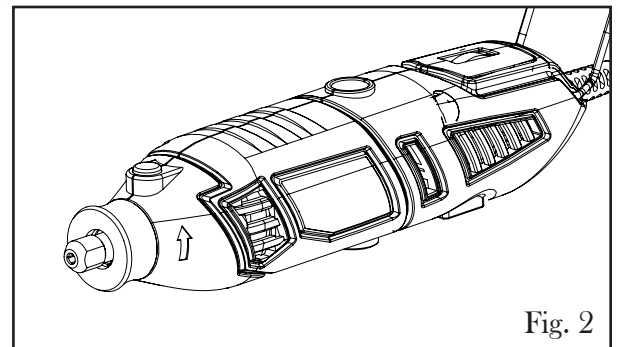
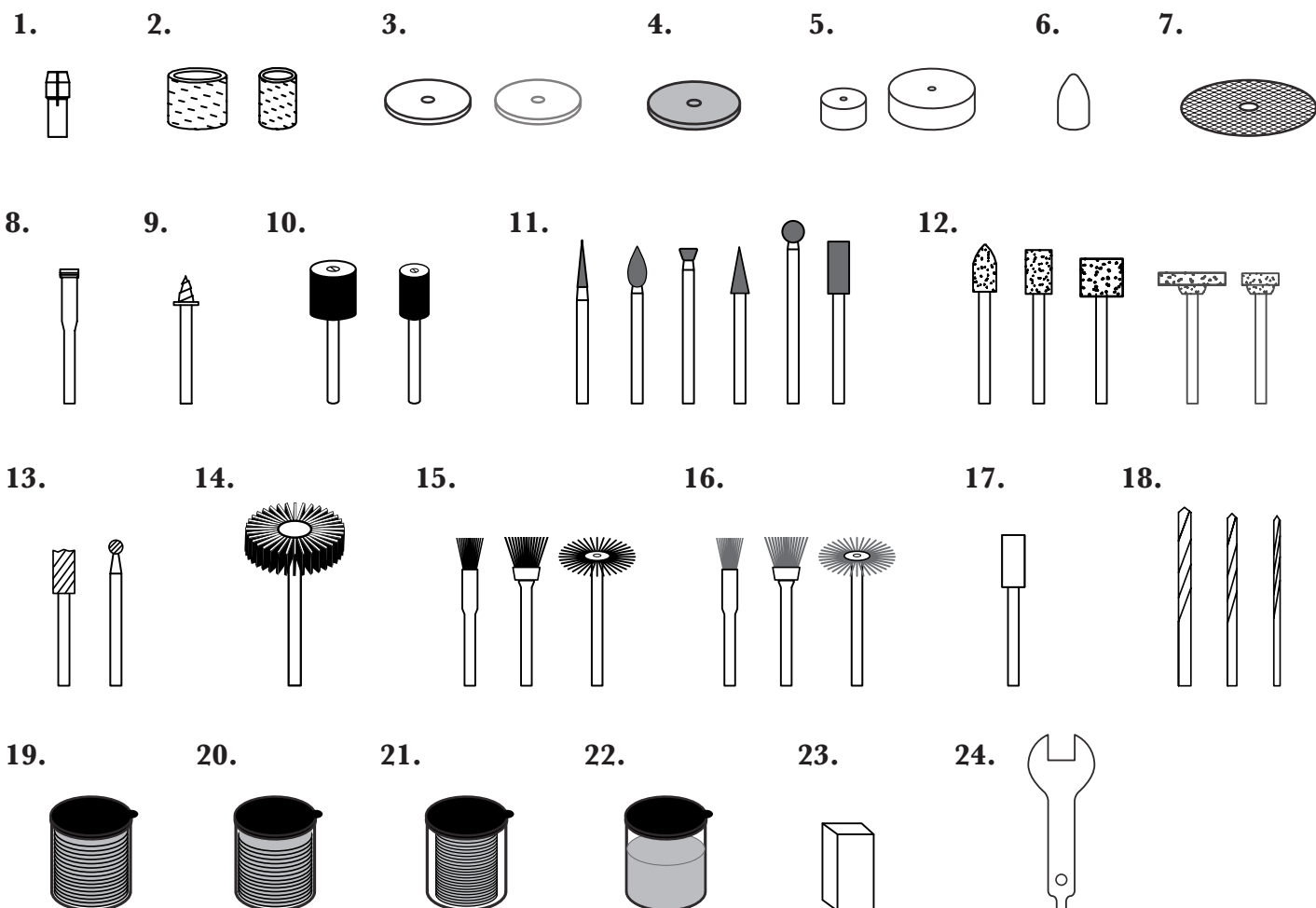

Fig. 2

KNOW YOUR ACCESSORIES

INCLUDED ACCESSORIES:



No.	Description	Qty.
1	Collet (Ø1/8", Ø3/32", Ø1/16")	4
2	Sanding Band, 120-Grit	16
3	Grinding Wheel (Red & Green)	10
4	Rubber Emery Wheel	1
5	Felt Polishing Wheel	7
6	Felt Polishing Tip	1
7	Fiberglass Cut-off Wheel	5
8	Small Screw Mandrel (Ø1/8")	2
9	Screw Mandrel (Ø1/8")	1
10	Sanding Drum Mandrel (Ø1/8")	2
11	Diamond Coated Bit (Ø1/8")	6
12	Grinding Stone Bit (Orange & Green, Ø1/8")	10

No.	Description	Qty.
13	HSS Cutter (Ø1/8")	2
14	Flap Wheel, 80 Grit (Ø1/8")	1
15	Nylon Wire Brush (Ø1/8")	3
16	Stainless Steel Wire Brush (Ø1/8")	3
17	Felt Polishing Bit (Ø1/8")	1
18	Drill Bit (Ø1/8", Ø3/32", Ø1/16")	6
19	Resin Cut-off Wheel, Regular	36
20	Resin Cut-off Wheel, Heavy Duty	30
21	Sanding Disc, 220-Grit	40
22	Polishing Compound, Paraffin	1
23	Dressing Stone	1
24	Wrench	1

KNOW YOUR ACCESSORIES

Refer to the chart below for explanations and recommended applications for your rotary tool accessory bits.

No.	Accessory	Explanation & Applications
1	Collet (Ø1/8", Ø3/32", Ø1/16")	For holding a rotary tool bit in place. Your tool comes with Ø1/8", Ø3/32", Ø1/16" sized collets. Always use the correct collet size that matches the shank diameter of the rotary tool bit.
2	Sanding Band (Big & Small)	Slides over the top of the sanding drum mandrel to sand and smooth around surfaces and inside curves. Replace the sanding bands when the grits are worn down. Do not use at speeds higher than 15,000 RPM. Attach to No. 10 Sanding Drum Mandrel (see page 13).
3	Grinding Wheel	<ul style="list-style-type: none"> • Aluminum Oxide Grinding Wheel (Red): Use for various grinding applications including sharpening blades and tools, removing flash from metal castings, deburring, smoothing welded joints, and removing rust. • Silicon Carbide Grinding Wheel (Green): For tougher materials such as glass and ceramics. Use for deburring, grinding and abrasive operations. <p>Attach to No. 8 Small Screw Mandrel (see page 13). Can be sharpened with No. 23 Dressing Stone.</p>
4	Rubber Emery Wheel	Use for removing rust, corrosion, paint from metal and other hard materials to produce a smooth, polished surface. Attach to No. 8 Small Screw Mandrel (see page 13).
5	Felt Polishing Wheel	Screws onto the top of the screw mandrel to clean, polish and buff metal, wood and plastics to a smooth and bright finish. Do not use at speeds higher than 15,000 RPM. Attach to No. 9 Screw Mandrel (see page 13).
6	Felt Polishing Tip	
7	Fiberglass Cut-off Wheel	Cut-off wheels reinforced with fiberglass. Use for cutting or slicing work on metal, wood and ceramics. Cut off bolt ends or make slots in stripped screws. Attach to No. 8 Small Screw Mandrel (see page 13).
8	Small Screw Mandrel (Ø1/8")	A mandrel with a threaded head and slotted tip for attaching wheel accessories (see page 13).
9	Screw Mandrel (Ø1/8")	A mandrel with a screw head for attaching felt polishing accessories (see page 13).
10	Sanding Drum Mandrel (Ø1/8")	A mandrel with a cylinder-shaped rubber tip for attaching sanding bands. Can be expanded or retracted using the back of No. 20 Wrench (see page 13).
11	Diamond Coated Bit (Ø1/8")	Bits of various shape to efficiently cut and engrave in wood, plastics, and soft metals such as aluminum, copper, and brass.

KNOW YOUR ACCESSORIES

No.	Accessory	Explanation & Applications
12	Grinding Stone Bit (Ø1/8")	<ul style="list-style-type: none"> • Aluminum Oxide Grinding Stone Bit (Orange): Bits of various shapes used for grinding and abrasive operations. Great for removing flash from metal castings, deburring metal after cutting, smoothing welded joints, grinding off rivets and removing rust. • Silicon Carbide Grinding Stone Bit (Green): For tougher materials such as glass and ceramics. <p>Attach to No. 8 Small Screw Mandrel (see page 13). Can be sharpened with No. 23 Dressing Stone.</p>
13	HSS Cutter Bit (Ø1/8")	Use for edge cutting, carving and creating slots and holes in plastics, wood and metals.
14	Flap Wheel, 80 Grit (Ø1/8")	Grinds and polishes flat or contoured surfaces for finishing operations. Do not use at speeds higher than 15,000 RPM.
15	Nylon Wire Brush (Ø1/8")	<ul style="list-style-type: none"> • Nylon Wire Brush: Comes in three shapes for general cleaning and polishing purposes. • Stainless Steel Wire Brush: For polishing aluminum, stainless steel and other metals.
16	Stainless Steel Wire Brush (Ø1/8")	<p>Do not use at speeds higher than 15,000 RPM. Can be used with No. 22 Polishing Compound for more efficient cleaning or polishing.</p> <p>CAUTION: Excessive pressure can damage the wires. Operate with light pressure and let the tips of the wire brush do the work.</p>
17	Felt Polishing Bit	Use for polishing and buffing jewelry, soft metal, wood and plastics.
18	Drill Bit (Ø1/8", Ø3/32", Ø1/16")	Drill into materials such as metal, hardwood, and plastics. Make sure to use the correct collet size for your drill bit.
19	Resin Cut-off Wheel, Regular	Thin disc used for slicing and cutting screws, sheet metal, thin wood and plastics. Only cut along the wheel's edge; do not use for sanding or cutting curves. Attach to No. 8 Small Screw Mandrel (see page 13).
20	Resin Cut-off Wheel, Heavy Duty	
21	Sanding Disc, 220-Grit	Disc-shaped sandpaper used for material removal and resurfacing. Attach to No. 8 Small Screw Mandrel (see page 13).
23	Dressing Stone	A solid block made of hard abrasive. Breathes new life back into old or worn grinding wheel and grinding stone bits.
24	Wrench	<p>Use the front of the wrench for loosening the collet nut to change collets.</p> <p>Use the back of the wrench for adjusting the screws on the sanding drum and small screw mandrel, and for opening the carbon brush covers.</p>

Compatible Rotary Tool Accessories Kits: 150-Piece (Model 230151A), 282-Piece (Model 230282A),
320-Piece (Model 230321A), 327-Piece (Model 230327A).

ASSEMBLY AND ADJUSTMENTS



WARNING: To avoid injury from accidental startups, always ensure that the tool is switched OFF and unplugged from the power supply before making adjustments or changing accessories.

INSTALLING WHEEL/DISC ACCESSORIES (Fig. 3)

Loosen and remove the screw at the top of the small screw mandrel. Remove the top red ring from the screw and slide the wheel or sanding disc above the bottom red ring (ensure the abrasive side of the disc is facing up for sanding disc). Slide the top red ring above the wheel/disc, so that there is one red ring on each side of the wheel. Reattach the screw onto the mandrel to secure the wheel/disc in place.

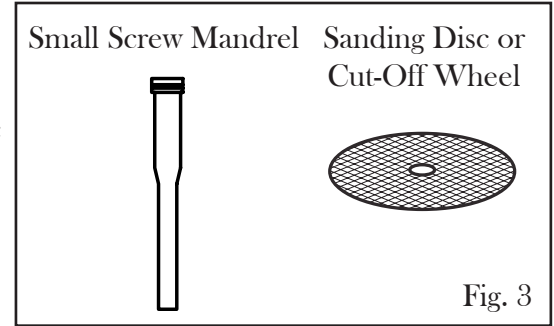

INSTALLING SANDING BANDS (Fig. 4)

Loosen the screw on the top of the sanding drum using the end of the included wrench to contract the width of the drum. Slide the sanding band onto the sanding drum. Fully tighten the screw to expand the width of the sanding drum to hold the sanding band in place. Make sure the sanding drum is sufficiently expanded to secure the band during use. If sanding band is loose on the drum, it may fly off during operation and cause injuries.

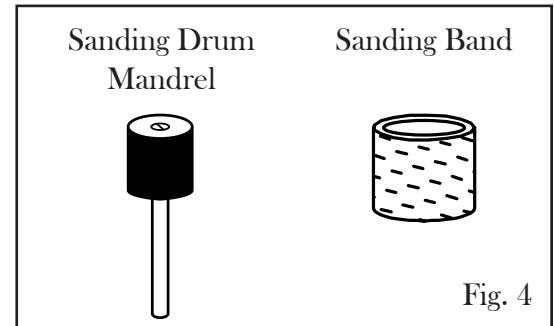

INSTALLING FELT POLISHING ACCESSORIES (Fig. 5)

Thread the felt polishing accessory straight down onto the tip of the screw mandrel. The accessory must be threaded all the way down to touch the collar of the screw mandrel.

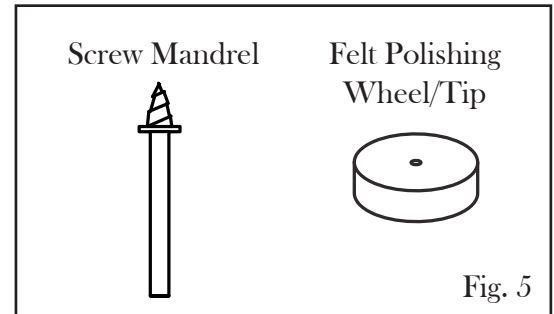

INSTALLING ROTARY TOOL BITS (Fig. 6)

1. Switch off and unplug the tool before making any adjustments.
2. Hold down the spindle lock button and rotate the collet nut until the spindle lock engages.
3. Using the included wrench, loosen and remove the collet nut by turning it counterclockwise. Release the spindle lock button.
4. An 1/8" collet is pre-installed inside the tool. Three collet sizes are included with your rotary tool as accessories: 1/8", 3/32" and 1/16". Select the suitable collet to match the spindle diameter of your desired rotary tool bit. Thread the selected collet onto the spindle and screw the collet nut back on, but do not tighten it all the way.
5. Fully insert the rotary bit into the spindle hole through the collet nut and collet. Press down the spindle lock button and fully tighten the collet nut using the included wrench. Pull on the rotary tool bit to check that it is firmly secured inside the tool.

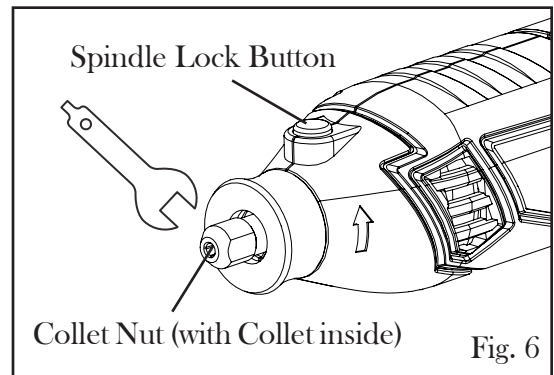

WARNING: Check to make sure that all accessories are assembled correctly and securely on the rotary tool. Do not use if any accessory or part is loose or damaged.

ASSEMBLY AND ADJUSTMENTS

ATTACHING THE FLEX SHAFT (Fig. 7 - 16)

FOR VIDEO INSTRUCTIONS ON ATTACHING THE FLEX SHAFT, VISIT: <http://bit.ly/wenflexshaft>

1. Unscrew and remove the locking collar from the end of the rotary tool (Fig. 7).



2. Use the 1/8" collet for attaching the flex shaft. Press down on the spindle lock button (Fig. 8) to unscrew the collet nut and check the collet size. Replace the collet nut.



3. Take the flex shaft from your tool kit and pull the inner core out about 2 to 3 inches (Fig. 9).



4. Insert the inner core of the flex shaft into the spindle hole through collet nut and collet (Fig. 10). Make sure that the golden metal ring is pressed tightly against the collet nut (Fig. 11). Press down on the spindle lock button, and fully tighten the collet nut with the included wrench.

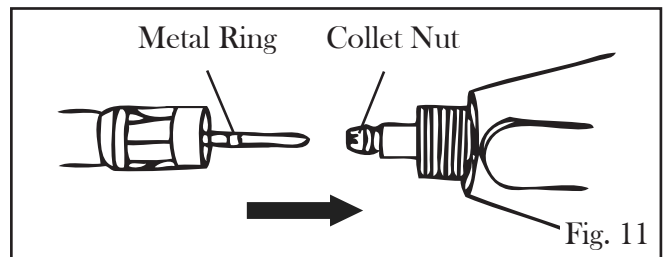

5. Now that the inner core is secured to the collet nut, slide down the silver flex shaft adapter and screw it onto the rotary tool by turning it clockwise (Fig. 12).



6. Take the L-shaped tool and insert it into the hole on the other end of the flex shaft handle to prevent the flex shaft spindle from rotating (Fig. 13).



7. Unscrew the flex shaft collet nut and check the size of the collet against your rotary bit. Use the correct size of collet for your desired rotary tool bit (Fig. 14).



8. Install the collet and collet nut, and fully insert the rotary bit into the center hole through the collet. Use the included wrench to fully tighten the collet nut and ensure that the bit is properly secured to the flex shaft (Fig. 15).



IMPORTANT: Follow the rules below when using your flex shaft to prevent overheating and causing personal injuries.

- Lubricate your flex shaft regularly to prevent overheating (see page 16).
- Do not bend the flex shaft near its connection to the rotary tool. Keep it straight.
- Never cross the flex shaft over itself during operation. Do not operate the flex shaft with a sharp bend. The recommended minimum radius for the flex shaft is 5 inches (Fig. 16). Bending the shaft farther than this can generate excessive heat and damage the flex shaft.

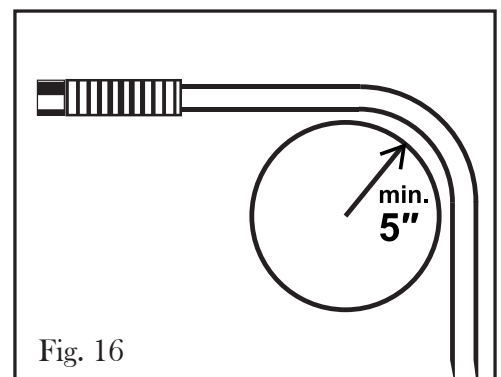

OPERATION



WARNING: Read and thoroughly understand all instructions and safety information before operating this rotary tool. Failure to do so may cause serious injury.

ADJUSTING THE SPEED OF THE ROTARY TOOL (Fig. 17)

The variable speed adjustment wheel on the top of the rotary tool is used to set the desired rotation speed. The speed for your rotary tool ranges from 8,000 to 35,000 RPM. To increase the speed, turn the wheel forward to a higher number. To decrease speed, turn the wheel backwards to a lower number.

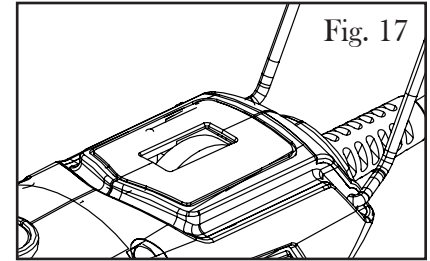

Set the suitable speed for your operation, workpiece and accessories:

- Use slow speeds for plastics, ceramics, precious metals and low-melting point materials to prevent damaging the material. All brushing applications and delicate polishing require slow rotary speeds lower than 15,000 RPM.
- Use higher speeds when working on wood, metal and glass. Drilling, carving, cutting, routing, shaping or rabbets are generally performed more efficiently at faster rotary speeds.

As a general rule, larger attachments should be used at a lower speed. The best way to determine the suitable speed is to test on a scrap piece of similar material, observe the results and adjust the speed accordingly.

OPERATING THE ROTARY TOOL

As with all power equipment, a rotary tool can be dangerous if it is not assembled or used properly. Do not operate this power tool if you have doubts or questions regarding operation safety. Call our customer service department at 1-800-232-1195 M-F 8-5 CST to address your questions or concerns.



WARNING: Always wear ANSI Z87.1-approved safety glasses, safety gloves and suitable work clothing. Do not wear jewelry, neckties or other loose clothing which could get caught in moving parts. Hold the tool away from your face and body in case parts and chips fly out unexpectedly during operation.



WARNING: Do not start or operate this tool in the presence of flammable liquids or gases. Sparks generated by the rotary tool could ignite these flammable materials.

1. Inspect the tool for any damage before use. Immediately discard any accessories with bent shafts or any other damage. Make sure that the ventilation slots on the tool are not obstructed, otherwise the motor may overheat.
2. The power switch is located on the underside of the handle. To switch on the tool, flip it to I (the ON position). To switch off the tool, flip the switch to O (the OFF position). Be certain the tool is in the OFF position when not in use and during all maintenance activities.
3. Set the suitable speed for your operation. Turn on the tool and let the motor reach full speed. Slowly lower the accessory bit onto the workpiece and guide the tool with light, even pressure.

NOTE: Do not exert excessive pressure on your tool as it may damage your workpiece and the accessory bit. Let the tool do the work. For better results, make several progressive passes until the desired cutting depth or finish is achieved.

4. Lift the tool away from the workpiece and turn OFF the switch. Wait for the tool to come to a complete stop before setting it down. Do not touch the rotary accessory or workpiece immediately after operation as they can be very hot. Follow the instructions on the next page for properly maintaining your tool and accessories.

MAINTENANCE



WARNING: Always switch OFF and disconnect the rotary tool from the power supply before carrying out any adjustments, service or maintenance.

IMPORTANT: Servicing of the tool requires extreme care and knowledge and should be performed only by a qualified service technician.

CLEANING AND INSPECTION

1. After each use, clean the tool and accessories using a clean cloth or a soft brush. **NEVER** use water or other liquids to clean the electrical portions of the tool.

2. Keep the ventilation openings free from dust and debris to prevent the motor from overheating.

3. Check the tool and accessories for any damage. Remove and dispose of damaged accessories.

LUBRICATING THE FLEX SHAFT

The flex shaft's inner coil rotates at high speed during operation, generating friction and heat. It is important to lubricate the inner coil of your flex shaft after several hours of operation to prevent it from overheating.

To lubricate the flex shaft, pull the inner coil out from the flex shaft. Apply an even coat of multi-purpose grease onto the entire surface of the inner coil. Insert the inner coil back into the flex shaft.

CARBON BRUSHES INSPECTION AND REPLACEMENT (Fig. 16 & 17)

To maintain efficiency of the motor, inspect the two carbon brushes routinely. The wear on the carbon brushes depends on how frequently and how heavily the tool is used. Replace the brushes when the brush length gets down to 1/8 of an inch or when the tool stops working.

NOTE: Replacement carbon brushes (Model 23190-009) can be purchased from wenproducts.com. Only genuine WEN replacement brushes designed specifically for your tool should be used.

1. The carbon brush caps are located on the top and bottom of the rotary tool (Fig. 16). To access the brushes, unscrew and remove the two brush caps using the end of the wrench included with your tool kit.

2. Take out and inspect the carbon brushes (Fig. 17). If the brushes are worn to under 1/8 inch in length, replace them with new carbon brushes and reinstall the brush caps. Both carbon brushes should be replaced at the same time. Fully tighten both brush caps with the wrench.

NOTE: Keep carbon brushes clean and ensure that they slide freely in the brush holders.

PRODUCT DISPOSAL

Used power tools contain recyclable materials and should not be disposed with household waste. Please take this product to your local recycling facility for responsible disposal and to minimize its environmental impact.

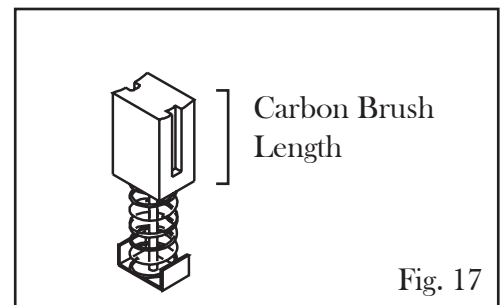
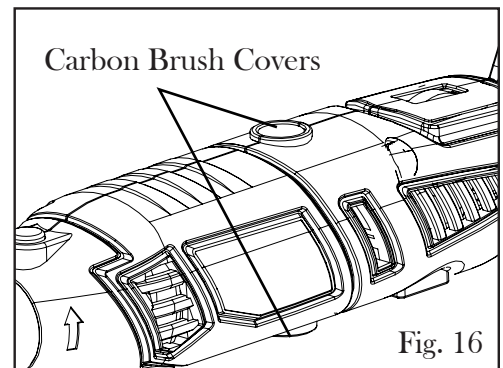

LIMITED ONE YEAR WARRANTY

WEN Products is committed to building tools that are dependable for years. Our warranties are consistent with this commitment and our dedication to quality.

LIMITED WARRANTY OF WEN CONSUMER POWER TOOLS PRODUCTS FOR HOME USE

GREAT LAKES TECHNOLOGIES, LLC (“Seller”) warrants to the original purchaser only, that all WEN consumer power tools will be free from defects in material or workmanship for a period of one (1) year from date of purchase. Ninety days for all WEN products, if the tool is used for professional use.

SELLER’S SOLE OBLIGATION AND YOUR EXCLUSIVE REMEDY under this Limited Warranty and, to the extent permitted by law, any warranty or condition implied by law, shall be the repair or replacement of parts, without charge, which are defective in material or workmanship and which have not been misused, carelessly handled, or misrepaired by persons other than Seller or Authorized Service Center. To make a claim under this Limited Warranty, you must make sure to keep a copy of your proof of purchase that clearly defines the Date of Purchase (month and year) and the Place of Purchase. Place of purchase must be a direct vendor of Great Lakes Technologies, LLC. Third party vendors such as garage sales, pawn shops, resale shops, or any other secondhand merchant void the warranty included with this product. Contact techsupport@wenproducts.com or 1-800-232-1195 to make arrangements for repairs and transportation.

When returning a product for warranty service, the shipping charges must be prepaid by the purchaser. The product must be shipped in its original container (or an equivalent), properly packed to withstand the hazards of shipment. The product must be fully insured with a copy of the warranty card and/or the proof of purchase enclosed. There must also be a description of the problem in order to help our repairs department diagnose and fix the issue. Repairs will be made and the product will be returned and shipped back to the purchaser at no charge.

THIS LIMITED WARRANTY DOES NOT APPLY TO ACCESSORY ITEMS THAT WEAR OUT FROM REGULAR USAGE OVER TIME INCLUDING BELTS, BRUSHES, BLADES, ETC.

ANY IMPLIED WARRANTIES SHALL BE LIMITED IN DURATION TO TWO (2) YEARS FROM DATE OF PURCHASE. SOME STATES IN THE U.S., SOME CANADIAN PROVINCES DO NOT ALLOW LIMITATIONS ON HOW LONG AN IMPLIED WARRANTY LASTS, SO THE ABOVE LIMITATION MAY NOT APPLY TO YOU.

IN NO EVENT SHALL SELLER BE LIABLE FOR ANY INCIDENTAL OR CONSEQUENTIAL DAMAGES (INCLUDING BUT NOT LIMITED TO LIABILITY FOR LOSS OF PROFITS) ARISING FROM THE SALE OR USE OF THIS PRODUCT. SOME STATES IN THE U.S. AND SOME CANADIAN PROVINCES DO NOT ALLOW THE EXCLUSION OR LIMITATION OF INCIDENTAL OR CONSEQUENTIAL DAMAGES, SO THE ABOVE LIMITATION OR EXCLUSION MAY NOT APPLY TO YOU.

THIS LIMITED WARRANTY GIVES YOU SPECIFIC LEGAL RIGHTS, AND YOU MAY ALSO HAVE OTHER RIGHTS WHICH VARY FROM STATE TO STATE IN THE U.S., PROVINCE TO PROVINCE IN CANADA AND FROM COUNTRY TO COUNTRY.

THIS LIMITED WARRANTY APPLIES ONLY TO PORTABLE ELECTRIC TOOLS, BENCH POWER TOOLS, OUTDOOR POWER EQUIPMENT AND PNEUMATIC TOOLS SOLD WITHIN THE UNITED STATES OF AMERICA, CANADA AND THE COMMONWEALTH OF PUERTO RICO. FOR WARRANTY COVERAGE WITHIN OTHER COUNTRIES, CONTACT THE WEN CUSTOMER SUPPORT LINE.

EXPLODED VIEW AND PARTS LIST

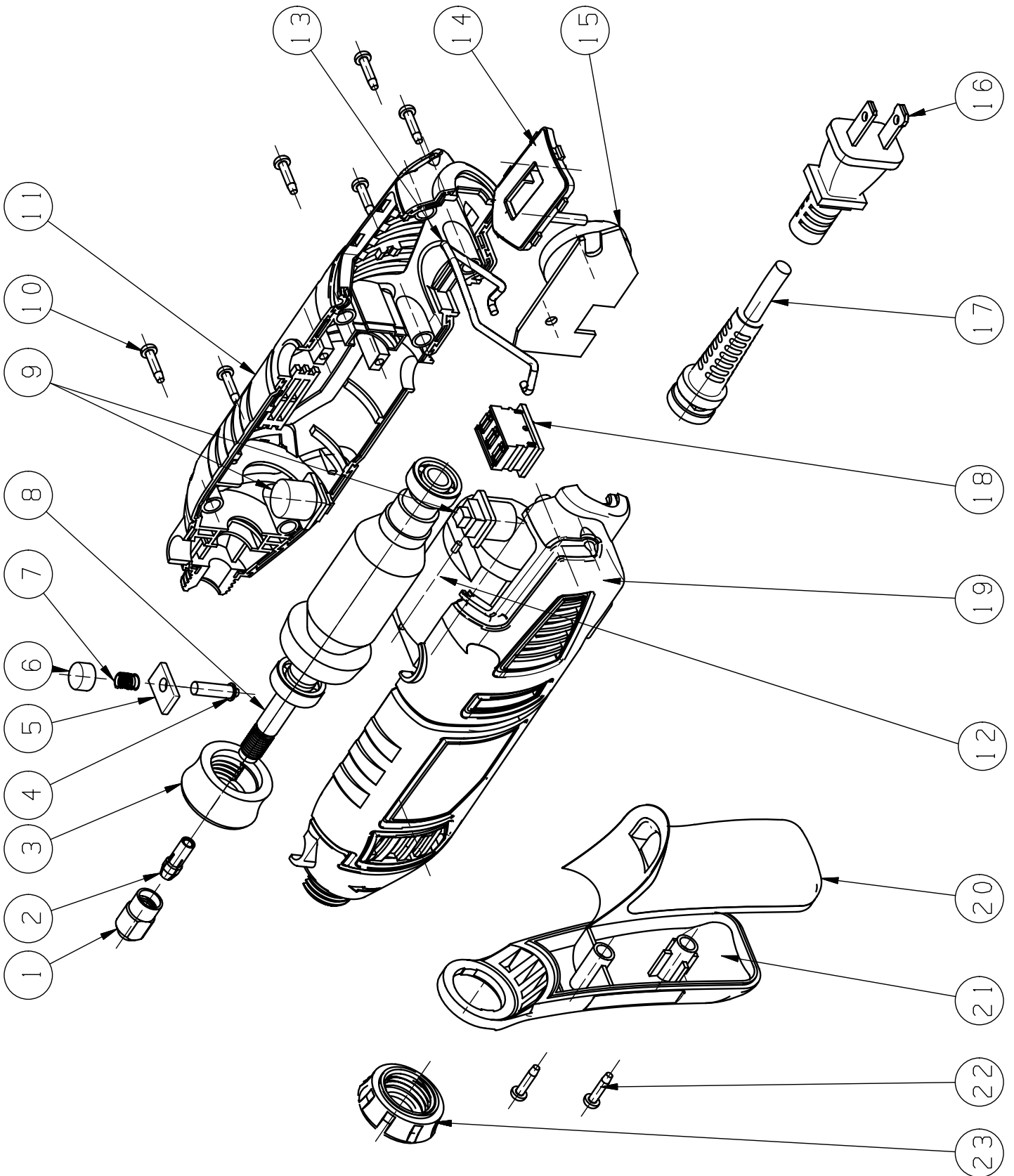

EXPLODED VIEW AND PARTS LIST

No.	Part No.	Description	Quantity
1	23190-001	Collet Nut	1
2	23190-002	Collet	1
3	23190-003	Cap Body	1
4	23190-004	Spindle Lock Button	1
5	23190-005	Gasket	1
6	23190-006	Spindle Locking Button	1
7	23190-007	Spindle Lock Spring	1
8	23190-008	Rotor	1
9	23190-009	Carbon Brush	2
10	23190-010	Screw	6
11	23190-011	Right Body	1
12	23190-012	Stator	1
13	23190-013	Hanger	1
14	23190-014	Speed Panel	1
15	23190-015	Circuit Board	1
16	23190-016	Plug	1
17	23190-017	Cord Sleeve	1
18	23190-018	Switch	1
19	23190-019	Left Body	1
20	23190-020	Right Handle	1
21	23190-021	Left Handle	1
22	23190-022	Screw	2
23	23190-023	Locking Collar	1

NOTE: Parts that wear down over the course of normal use (like accessories, carbon brushes, etc.) are not covered by the two-year warranty. Repairs and replacements should only be performed by an authorized technician.

**THANKS FOR
REMEMBERING**

