

Porto-Power Kit

Operating Instructions & Parts Manual

| Model Number | Capacity |
|--------------|----------|
| B65114 | 4 Ton |
| B65115 | 10 Ton |

Model B65114

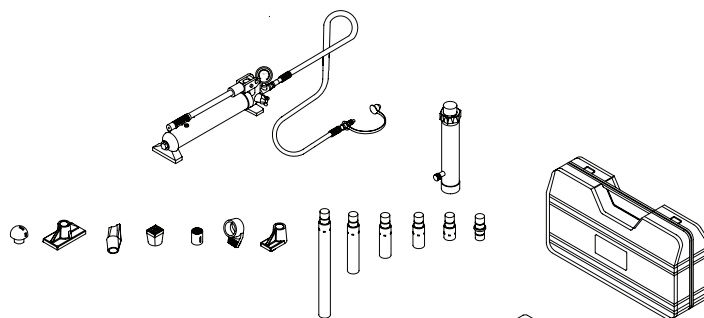

Model B65115

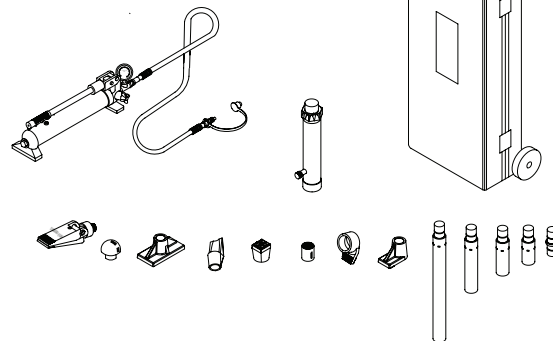

This is the safety alert symbol. It is used to alert you to potential personal injury hazards. Obey all safety messages that follow this symbol to avoid possible injury or death.

! ADVERTENCIA

- Leer, comprender, y seguir las instrucciones antes de utilizar el aparato.
- El manual de instrucciones y la información de seguridad deben estar comunicado en lengua del operador antes del uso.
- No seguir estas indicaciones puede causar daños personales o materiales.

SFA Companies
10939 N. Pomona Ave. Kansas City, MO 64153
sales@blackhawk-automotive.com

Read this manual and follow all the Safety Rules and Operating Instructions before using this product.

SAFETY and GENERAL INFORMATION

Save these instructions. For your safety, read and understand the information contained within. The owner and operator shall have an understanding of this product and safe operating procedures before attempting to use this product. Instructions and Safety information shall be conveyed in the operators native language before use of this product is authorized. Make certain that the operator thoroughly understands the inherent dangers associated with the use and misuse of the product. If any doubt exists as to the safe and proper use of this product as outlined in this factory authorized manual, remove from service.

Inspect before each use. Do not use if broken, bent, cracked or otherwise damaged parts are noted. If any component of this product has been or suspected to have been subjected to a shock load (a load dropped suddenly, unexpectedly upon it), discontinue use until checked out by an Porto-Power Blackhawk Automotive authorized service center. Owners and operators of this equipment shall be aware that the use and subsequent repair of this equipment may require special training and knowledge. It is recommended that an annual inspection be done by qualified personnel and that any missing or damaged parts, decals, warning/safety labels or signs be replaced with factory authorized replacement parts only. Any component of this Porto-Power Kit that appears to be damaged in any way, is worn or operates abnormally shall be removed from service immediately until such time as it can be repaired/replaced. Labels and Operator's Manuals are available from manufacturer.

PRODUCT DESCRIPTION

Porto-Power Kits are designed to be used for pushing, spreading, and pressing of vehicle body panels as well as various component parts and assemblies. A variety of attachments are included. B65114 is rated at 8,000 PSI; B65115 is rated at 10,000 PSI. Rams are rated from 4 to 10 tons respectively.

⚠ WARNING: *To reduce the risk of personal injury and/or property damage, ensure that the rated working pressure of each pressurized attachment be equal to or greater than the rated working pressure developed by the hydraulic pump.*

⚠ *Always check connections before using. Alteration of these products is strictly prohibited. Use only those adapters and attachments provided and approved by the manufacturer.*

Note: when extension tubes and/or offset attachments are used, the rated capacity is always reduced by 50% for each tube or offset attachment connected. See Parts Section for identification of "offset" attachments.

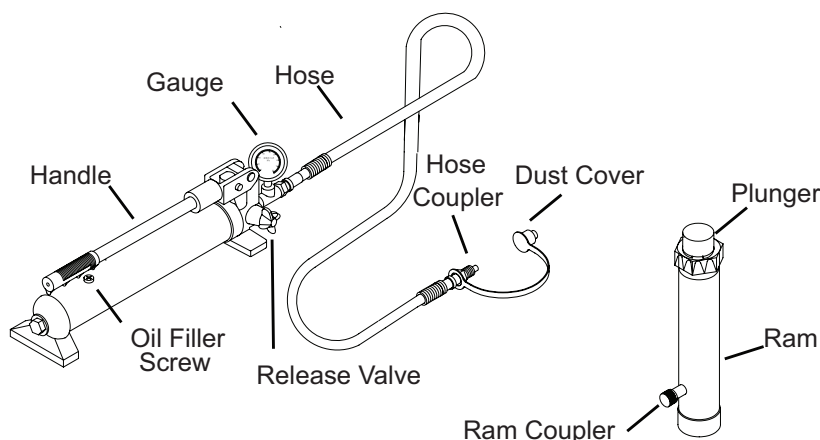

Figure 1 - Pump and Ram Components

SPECIFICATIONS

| Model | Pump Capacity (psi) | Ram Capacity (ton) | Ram | | | Number of Attachments | Weight (lb) |
|--------|------------------------|-----------------------|-----------------------|-------------------------|--------------------------------------|-----------------------|----------------|
| | | | Closed Height (in) | Extended Height (in) | Effective area (in ²) | | |
| B65114 | 8,000 | 4 | 11 | 15 3/4 | 0.998 | 14 | 46 |
| B65115 | 10,000 | 10 | 13 5/8 | 19 3/4 | 2.411 | 13 | 84 |

!WARNING



Failure to comply with the following warnings may result in **personal injury** as well as **property damage**.



- Study, understand, and follow all instructions provided with and on this device before use.
- The user must be a qualified operator familiar with the correct operation, maintenance, and use of rams.



Wear protective gear when operating hydraulic equipment.



This device is **NOT** suitable for use as **support** device! As the load is lifted, use blocking and cribbing to guard against a falling load. Stay clear of a lifted load before it is properly supported. Never rely on hydraulic pressure to support a load.



Crush Hazard. Keep hands and feet away from ram and workpiece during operation.



- Do not exceed rated capacity of the ram or any equipment in the system. The ram is designed for a max. pressure of 10,000 psi.
- Do not connect a ram to a pump with higher pressure rating.
- Do not subject ram to a shock loads, a load dropped suddenly, causing the system pressure to exceed rated pressure.



The system operating pressure must not exceed the pressure rating of the lowest rated component the system. Install a pressure gauge or other load measuring instrument to monitor the operating pressure. Burst hazard exists if hose, connection or any other component in the system exceed its rated pressure.



Avoid damaging hydraulic hose. Do not allow hose to kink, twist, curl, crush, cut or bend so tightly that fluid flow within the hose is blocked or reduced. Periodically inspect the hose for wear.



Do not pull, position or move ram setup by the hose. Use carrying handle or other means of safe transport.



Do not handle pressurized hoses. Never attempt to grasp a leaking pressurized hose. Ensure to release the system pressure before disconnecting hydraulic hose or connections.



Hydraulic fluid can ignite and burn. Keep hydraulic equipment away from flames and heat. Excessive heat will soften seals, resulting in fluid leaks. Heat also weakens hose materials.

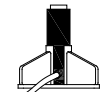

Ram must be on a stable base which is able to support the load while pushing or lifting. Use shims, friction material or constrains to prevent slippage of the base or load. Ensure ram is fully engaged into/onto adapters, extension accessories.

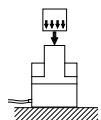

Center load on ram. Distribute load evenly across the entire saddle surface. Do not off-center loads on a ram. The load can tip or the ram can “kick out”.



Never try to disassemble a hydraulic ram, refer repairs to qualified, authorized personal. Contact Porto-power tech service for authorized service center.



Do not subject hose to sharp objects or heavy impact.



Hose material or seals must not come in contact with corrosive materials such as battery acid, creosote-impregnated objects and wet paint. Never paint a coupler or hose.



- No alteration shall be made to the ram.
- Use only factory authorized fasteners, accessories and hydraulic fluid.

BEFORE USE

1. Before using this product, read the owner's manual completely and familiarize yourself thoroughly with the product, its components and recognize the hazards associated with its use.
2. Inspect before each use. Do not use if bent, broken, leaking or damaged components are noted.
3. Check to ensure that all parts of your kit are included (see illustration and parts list).
4. Carefully remove the dust caps and plugs from hose coupler and ram coupler.
5. Connect hose coupler to ram coupler, ensure that there are no fluid leaks.
6. Locate and open release valve. Close release valve clockwise and pump handle until ram is fully extended, then open release valve counter-clockwise until ram has fully retracted.
7. With ram fully retracted and release valve open, place pump in horizontal position. Open oil filler screw (on reservoir body, near the back). This will release air trapped within the reservoir. Re-tighten the oil filler screw.
8. If using with air actuated units, an air source of at least 7.8 CFM @ 110 psi is required.

GENERAL SAFETY INFORMATION

1. Ensure that attachments are fully engaged before applying load.
2. Ensure that load is centrally applied to attachment or ram saddle. Do not load off center.
3. Always monitor the force applied to workpiece by using a load cell and indicator or you may monitor pressure developed in the ram by using an inline pressure gauge, then calculate the applied force using the formula:
 $F = P \times A$, where $F = \text{lb force}$, $P = \text{pressure in psi}$, and $A = \text{effective ram area in in}^2$.
Ram Area of Model B65114 is: 0.998 in²
Ram Area of Model B65115 is: 2.411 in²
Refer to Load-Pressure correlation chart on page 11.
If bowing or bending of ram or any attachment occurs during use, **"STOP"**, release pressure immediately and reconsider application. Application may not be compatible with product, a ram kit with a higher capacity may be needed.

OPERATION

! ALWAYS monitor pressure, load or position using suitable equipment. Pressure may be monitored by means of an optional manifold and gauge. Load may be monitored by means of a load cell and digital indicator.

Note: Any attachment that is not loaded centrally, as through the centerline of the ram, is considered to be "offset". When extension tubes and/or offset attachments are used, the rated capacity is always reduced by 50% for each tube or offset attachment connected.

1. Pump may be used in horizontal and vertical position as illustrated on figure 2 below.

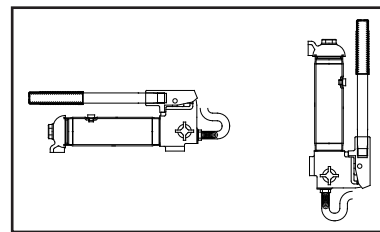

Figure 2 - Horizontal and Vertical position

2. Locate and close release valve by turning it clockwise until firmly closed. (Do not over tighten)
3. Operate by pumping handle. This will send fluid from the pump reservoir into the high pressure hose assembly and into the ram assembly.
4. Continue pumping until ram reaches desired position.

! NEVER operate pump with release valve closed and disconnected from application. If operated in this condition, the hose and connections become pressurized. This increases burst hazard. Damage may occur to pump and its components.

5. To Release Pressure on work piece: Slowly, carefully turn the release valve counter-clockwise until ram retracts to desired position. Never turn release valve more than 1/2 full turn. The ram return system is spring loaded and the release valve system is metered, allowing controlled retraction of the ram.

Basic Setup

The capacity of the body repair kit can be significantly affected by the number of attachments used and the type of load applied. The approximate load capacity of each function setup is illustrated below. When two or more extension tubes are used together, be sure to position the shortest tube further away from the ram.

Note: Not all accessories in the illustrations provided in the Porto-Power Kits.

A. Push & Stretch

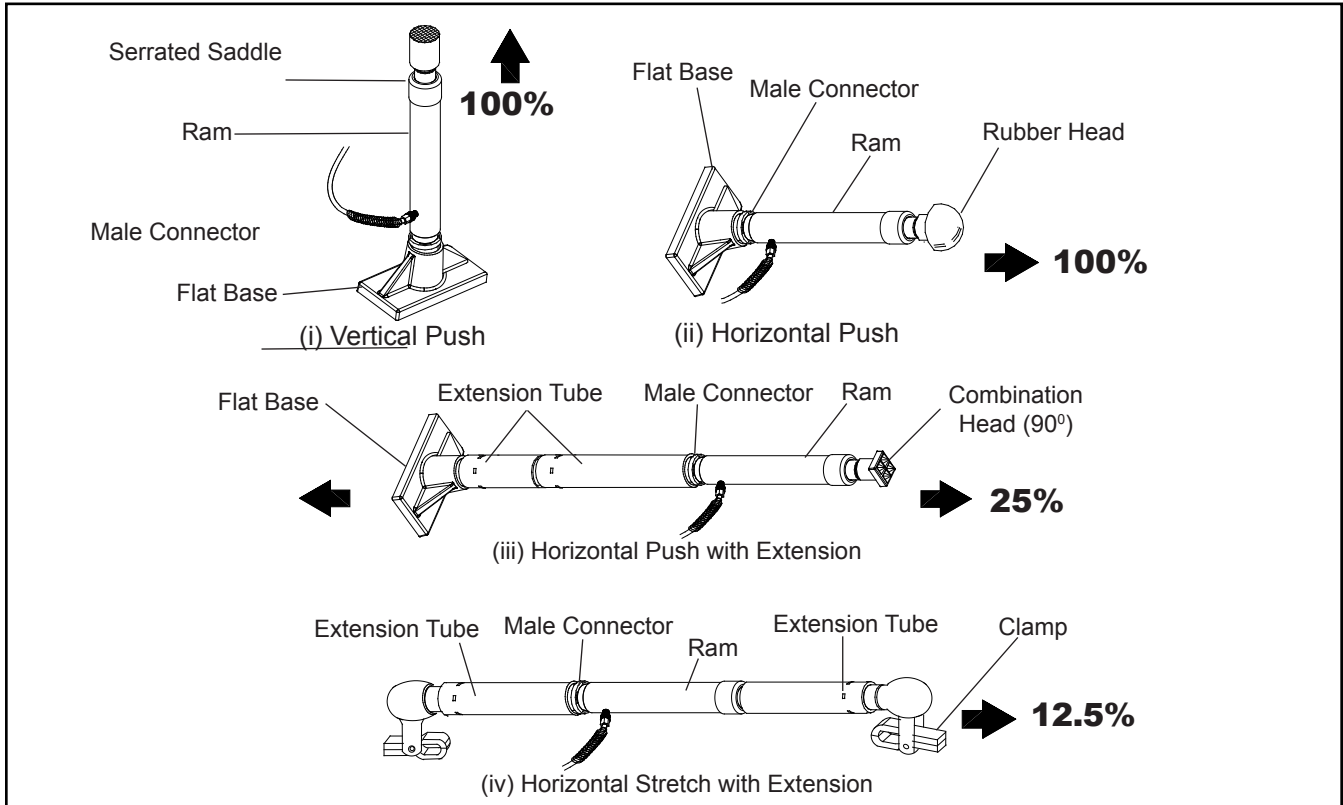

B. Clamp & Pull

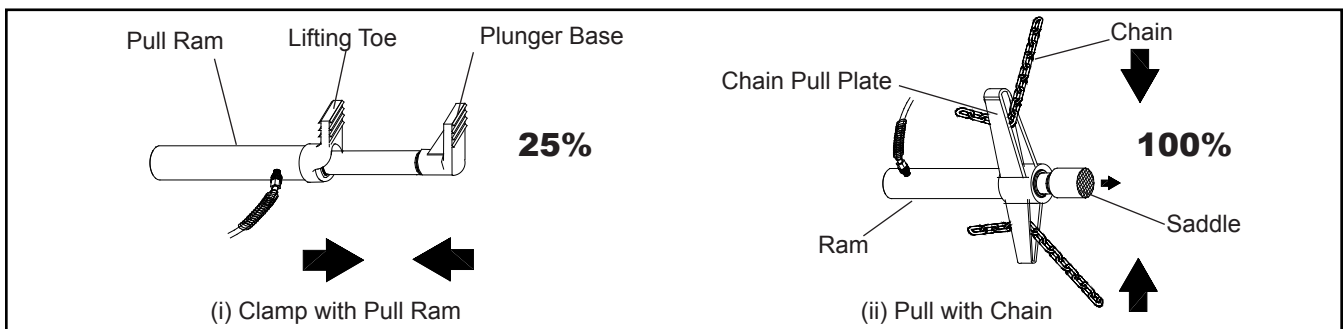

C. Spread

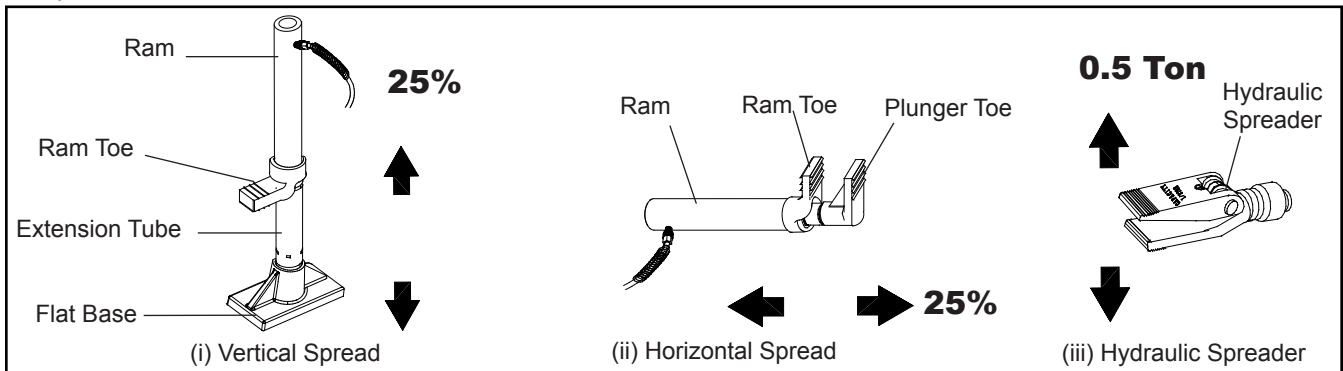

MAINTENANCE

1. Inspect hoses and connections daily. Replace damaged components immediately with Porto-Power Automotive Replacement Parts only.
2. Tighten connections as needed. Use pipe thread sealing compound when servicing connections.
3. Use only a good grade hydraulic oil. Avoid mixing different types of fluid and Never use brake fluid, turbine oil, transmission fluid, motor oil or glycerin. Improper fluid can cause premature failure of the ram and the potential for sudden and immediate loss of load. We recommend Hein-Werner HW93291 or equivalent.

Adding oil

1. With ram fully lowered, set pump unit in its normal, level position. Locate and remove oil filler screw.
2. Fill until oil is within 3/8" of the oil filler screw hole opening, re-install oil filler screw.

Changing oil

For best performance and increased system life, replace the complete fluid supply at least once per year.

1. With ram fully lowered, remove the oil filler screw from the pump reservoir as above.
2. Lay the pump on its side and drain the fluid into a suitable container.

Note: Dispose of hydraulic fluid in accordance with local regulations.

3. Set pump in its level upright position.
4. Fill with good quality jack oil to within 3/8" of the oil filler screw hole opening. Reinstall oil filler screw.

Lubrication

A coating of light lubricating oil to pivot points and hinges will help to prevent rust and assure that pump assemblies move freely.

Cleaning

Periodically check the pump piston and ram for signs of rust or corrosion. Clean as needed and wipe with an oily cloth.

Note: Never use sandpaper or abrasive material on these surfaces!

Storage

When not in use, store with the pump piston and ram fully retracted.

How to remove faulty coupler:

If ram does not retract,:

1. Secure load by other means.
2. Depressurize pump and hose
3. Remove the ram from application.
4. Disconnect and replace with new coupler.

Important: Do not attempt to grasp ram with pliers or wrench without first wrapping the jaws of such tool with rags or similar padding.

How to bleed air from system:

1. Place pump at a higher elevation than the hose and ram as shown in figure 3 below.
2. Operate pump to fully extend and retract the ram 2 or 3 times. The objective is to force the air bubbles up hill and back to the pump reservoir.
3. To bleed the air from pump reservoir, simply open the oil filler screw. Re-install after bleeding.

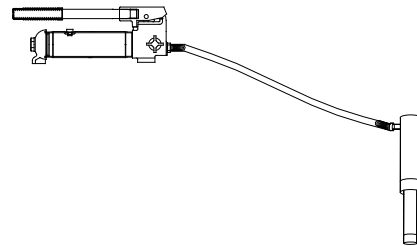

Figure 3 - Illustration to bleed air from system

TROUBLESHOOTING GUIDE

The following information is intended as an aid in determining if problem exists. Pump and ram should be repaired only by authorized Porto-Power Service Center. For repair service, contact service center in your area.

| Symptom | Possible Causes | Corrective Action |
|--|--|---|
| Erratic action | <ul style="list-style-type: none"> • Air in system or pump cavitation. • External leakage in ram. • Ram sticking or binding. | <ul style="list-style-type: none"> • Vent the system (refer to figure 3). • Contact service center. • Contact service center. |
| Ram will not extend, or respond to pressurized fluid | <ul style="list-style-type: none"> • Overload condition. • Loose/Faulty couplers. • Oil level in pump is low. | <ul style="list-style-type: none"> • Remedy overload condition. • Tighten/Replace couplers. • Fill and bleed the system. |
| Ram extend only partially | <ul style="list-style-type: none"> • Oil level in pump is low. • Overload condition. • Ram is sticking or binding. • Pump malfunction. | <ul style="list-style-type: none"> • Fill and bleed the system. • Remedy overload condition. • Contact service center. • Contact service center. |
| Ram move slower than normal | <ul style="list-style-type: none"> • Loose connection or coupler. • Restricted hydraulic line or fitting. • Pump not working correctly. • Ram seals leaking. | <ul style="list-style-type: none"> • Tighten connection or coupler. • Clean and replace if damaged. • Check pump's operating instructions. • Contact service center. |
| Ram responds to pressurized fluid, but system does not maintain pressure | <ul style="list-style-type: none"> • Overload condition. • Pump malfunctioning. • Ram seals leaking. | <ul style="list-style-type: none"> • Remedy overload condition. • Contact service center. • Contact service center. |
| Oil leaking from ram | <ul style="list-style-type: none"> • Worn or damaged seals. | <ul style="list-style-type: none"> • Contact service center. |
| Ram will not retract or retracts slower than normal | <ul style="list-style-type: none"> • Malfunctioning coupler, damaged application. • Pump reservoir overfilled. • Ram damage internally. | <ul style="list-style-type: none"> • Secure load by other means. Depressurize pump and hoses, remove application and replace coupler. • Secure load by other means. Depressurize pump and hoses, remove application, then drain fluid to proper level. • Contact service center. |
| Poor performance | <ul style="list-style-type: none"> • Oil level in pump is low. • Air trapped in system. | <ul style="list-style-type: none"> • Ensure proper oil level. • Vent the system (refer to figure 3). |

REPLACEMENT PARTS

Not all components of the porto-power kit are replacement items, but are illustrated as a convenient reference of location and position in the assembly sequence. When ordering parts, give Model number, serial number and description below. Call or write for current pricing: SFA Companies 10939 N. Pomona Ave. Kansas City, MO 64153, U.S.A. Tel:(888)332-6419 Fax:(816)891-6599 E-Mail: sales@blackhawk-automotive.com

Model B65114

| Item | Part No. | Description | Qty |
|------|----------------|--|-----|
| 1 | B65186 | Pump Assembly | 1 |
| 2 | B65187 | Ram Assembly | 1 |
| 3 | B65291 | Hose Assembly (with coupler) | 1 |
| 4 | B65067 | Blow Molded Case | 1 |
| 5 | B65123 | Hydraulic Spreader (1000 lb. capacity) | 1 |
| 6 | B65152 | Combination Head | 1 |
| 7 | B65178 | Rubber Head | 1 |
| 8 | B65155 | Ram Toe | 1 |
| 9 | B65154 | Plunger Toe | 1 |
| 10 | B65156 | Flat Base | 1 |
| 11 | B65151 | Serrated Saddle | 1 |
| 12 | B65153 | Wedge Head | 1 |
| 13 | B65177 | Male connector | 1 |
| 14 | B65157 | Extension Tube (3") | 1 |
| 15 | B65158 | Extension Tube (6-1/8") | 1 |
| 16 | B65159 | Extension Tube (8-1/2") | 1 |
| 17 | B65160 | Extension Tube (16-1/2") | 1 |
| 18 | B65161 | Extension Tube (19-1/2") | 1 |
| 19 | F040-21000-000 | Release Valve Knob | 1 |
| 20 | B69477 | Ram Coupler Assy, Female | 1 |
| 21 | F040-20012-000 | Dust Cover - Hose | 1 |
| 22 | F040-90009-K03 | Pump Handle | 1 |
| 23 | F040-90107-K02 | Oil Filler Screw | 1 |
| 24 | F100-80001-000 | Gauge | 1 |
| - | F0400S-85 | Repair Kit | - |
| - | B65114-L0 | Label | 1 |
| - | B65114-M0 | Manual | 1 |

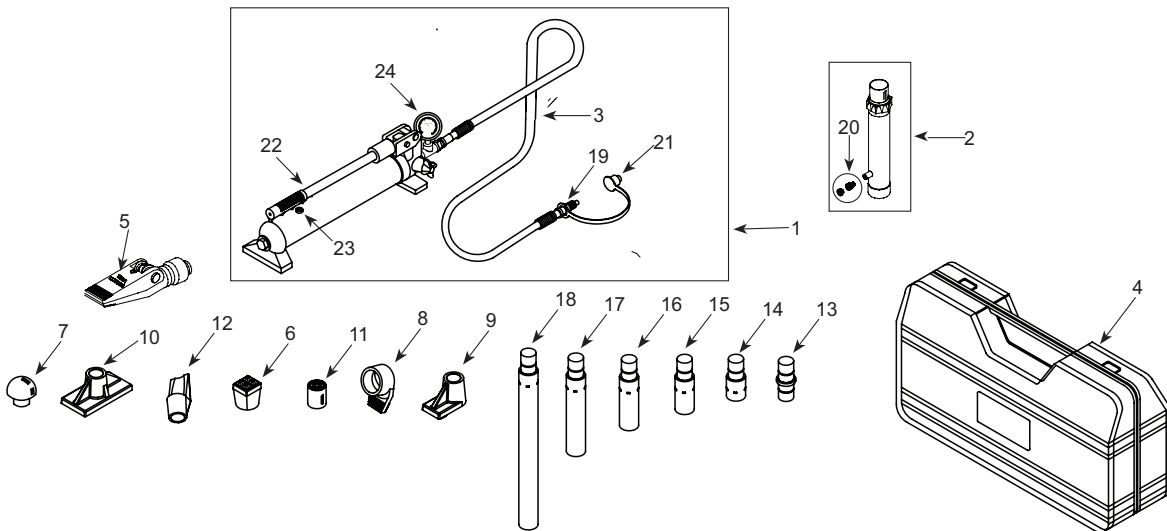

Figure 4 - Replacement Parts Illustration for Model B65114

Model B65115

| Item | Part No. | Description | Qty |
|------|----------------|--|-----|
| 1 | B65188 | Pump Assembly | 1 |
| 2 | B65189 | Ram Assembly | 1 |
| 3 | B65291 | Hose Assembly | 1 |
| 4 | B65068 | Blow Molded Case | 1 |
| 5 | B65123 | Hydraulic Spreader (1000 lb. capacity) | 1 |
| 6 | B65173 | Combination Head (90°) | 1 |
| 7 | B65180 | Rubber Head | 1 |
| 8 | B65169 | Ram Toe (offset) | 1 |
| 9 | B65172 | Plunger Toe (offset) | 1 |
| 10 | B65168 | Flat Base | 1 |
| 11 | B65167 | Serrated Saddle | 1 |
| 12 | B65166 | Wedge Head (offset) | 1 |
| 13 | B65179 | Male Connector | 1 |
| 14 | B65165 | Extension Tube (4") | 1 |
| 15 | B65164 | Extension Tube (10") | 1 |
| 16 | B65163 | Extension Tube (18") | 1 |
| 17 | B65162 | Extension Tube (27") | 1 |
| 18 | F040-90107-K02 | Oil Filler Screw | 1 |
| 19 | B69478 | Hose Coupler, Male | 1 |
| 20 | B69477 | Ram Coupler Assy, Female | 1 |
| 21 | F040-20012-000 | Dust Cover - Hose | 1 |
| 22 | F100-90009-K01 | Pump Handle | 1 |
| 23 | F100-80001-000 | Gauge | 1 |
| - | F1000S-85 | Repair Kit | - |
| - | B65115-L0 | Label (not shown) | 1 |
| - | B65114-M0 | Manual | 1 |

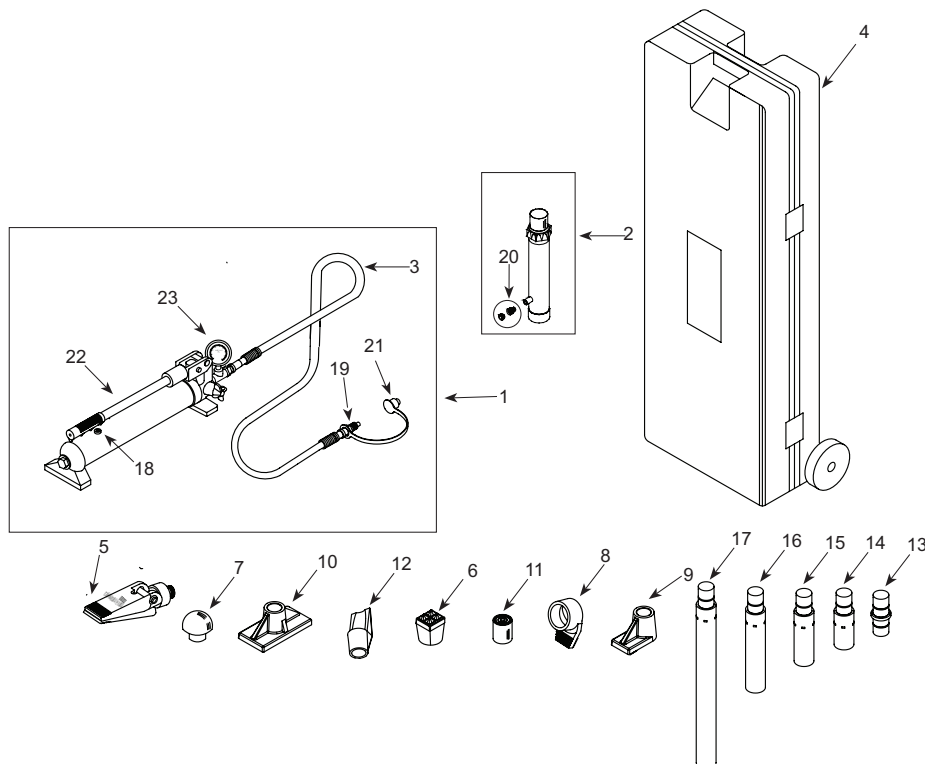

Figure 5 - Replacement Parts Illustration for Model B65115

ONE YEAR LIMITED WARRANTY

For a period of one (1) year from date of purchase, SFA Companies will repair or replace, at its option, without charge, any of its products which fails due to a defect in material or workmanship under normal usage. This limited warranty is a consumer's exclusive remedy.

Performance of any obligation under this warranty may be obtained by returning the warranted product, freight prepaid, to SFA Companies Warranty Service Department, 10939 N. Pomona Ave., Kansas City, MO 64153.

Except where such limitations and exclusions are specifically prohibited by applicable law.

- (1) THE CONSUMER'S SOLE AND EXCLUSIVE REMEDY SHALL BE THE REPAIR OR REPLACEMENT OF DEFECTIVE PRODUCTS AS DESCRIBED ABOVE.
- (2) SFA COMPANIES SHALL NOT BE LIABLE FOR ANY CONSEQUENTIAL OR INCIDENTAL DAMAGE OR LOSS WHATSOEVER.
- (3) ANY IMPLIED WARRANTIES, INCLUDING WITHOUT LIMITATION THE IMPLIED WARRANTIES OF MERCHANTABILITY AND FITNESS FOR A PARTICULAR PURPOSE, SHALL BE LIMITED TO ONE YEAR, OTHERWISE THE REPAIR, REPLACEMENT OR REFUND AS PROVIDED UNDER THIS EXPRESS LIMITED WARRANTY IS THE EXCLUSIVE REMEDY OF THE CONSUMER, AND IS PROVIDED IN LIEU OF ALL OTHER WARRANTIES, EXPRESS OR IMPLIED.
- (4) ANY MODIFICATION, ALTERATION, ABUSE, UNAUTHORIZED SERVICE OR ORNAMENTAL DESIGN VOIDS THIS WARRANTY AND IS NOT COVERED BY THIS WARRANTY.

Some states do not allow limitations on how long an implied warranty lasts, so the above limitation may not apply to you. Some states do not allow the exclusion or limitation of incidental or consequential damages, so the above limitation or exclusion may not apply to you. This warranty gives you specific legal rights, and you may also have other rights which vary from state to state.



SFA Companies
10939 N. Pomona Ave. Kansas City, MO 64153
816-891-6390
sales@blackhawk-automotive.com

Load - Pressure Correlation For Model B65114 & B65115

Always monitor the force applied to workpiece by using a load cell and indicator or you may monitor pressure developed in the ram by using an inline pressure gauge, then calculate the applied force using the formula:

$F = P \times A$

where F = Force/ Load (lb);
 P = Hydraulic working pressure (psi) and;
 A = Ram effective area (in²)

For model B65114, A = 0.998 in² ;
 For model B55115, A = 2.411 in²

Example1

Model B65114 lifting 5,000 lb will require what pressure?

Pressure = 5,000 lb / 0.998 in² = 5,010 psi

Example2

Model B65115 operating at 6,000 psi will generate what force?

Force = 6,000 psi x 2.411 in² = 14,466 lb

| Load (lb) | Pressure of 4 Ton Ram, where A = 0.998 in ² (psi) | Pressure of 10 Ton Ram, where A = 2.411 in ² (psi) |
|--------------|--|---|
| 1,000 | 1,002 | 415 |
| 2,000 | 2,004 | 830 |
| 3,000 | 3,006 | 1,244 |
| 4,000 | 4,008 | 1,659 |
| 5,000 | 5,010 | 2,074 |
| 6,000 | 6,012 | 2,489 |
| 7,000 | 7,014 | 2,903 |
| 8,000 | 8,016 | 3,318 |
| 9,000 | \ | 3,733 |
| 10,000 | | 4,148 |
| 11,000 | | 4,562 |
| 12,000 | | 4,977 |
| 13,000 | | 5,392 |
| 14,000 | | 5,807 |
| 15,000 | | 6,221 |
| 16,000 | | 6,636 |
| 17,000 | | 7,051 |
| 18,000 | | 7,466 |
| 19,000 | | 7,881 |
| 20,000 | | 8,295 |

Load - Combination Correlation For Model B65114 & B65115

Always consider the number of attachments that you are using and follow the combination load suggestions in the Basic Setup section on page 5. Follow the below table for correlation between percentage, load and pressure.

| | B65114 | | B65115 | |
|--------------|-----------|----------------|-----------|----------------|
| Percentage % | Load (lb) | Pressure (psi) | Load (lb) | Pressure (psi) |
| 100% | 8,000 | 8,016 | 20,000 | 8,295 |
| 50% | 4,000 | 4,008 | 10,000 | 4,148 |
| 25% | 2,000 | 2,004 | 5,000 | 2,074 |
| 12.5% | 1,000 | 1,002 | 2,500 | 1,037 |

SFA Companies
10939 N. Pomona Ave. Kansas City, MO 64153
Tel: 888-332-6419
E-mail: sales@blackhawk-automotive.com