

MODEL 765H80L HEATER / FAN / LIGHT

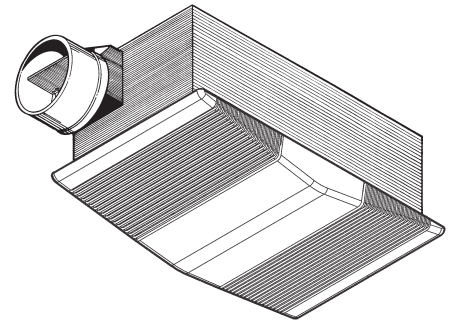

Quiet combination unit, built with high performance blower and attractive styling.

FEATURES

GRILLE:

- Bright white grille
- Snap-in light diffusing lens for 14W (max.) LED bulb (bulb not included)

VENTILATOR:

- Resilient anti-vibration mounts
- Plug-in, permanently lubricated motor
- Low sound, high performance blower wheel

HEATER:

- 1300 watts, with metal blower wheel for efficient, even heating
- Plug-in, permanently lubricated motor - functions independent of ventilator

HOUSING:

- Adjustable mounting brackets span up to 24"
- Polymeric damper/duct connector with 2" long tapered sleeve and no metallic clatter
- Compact 23 gage steel housing finished with powder coat paint

NOTE: For installation in ceilings up to 12/12 pitch

- Suitable for use in insulated ceilings (Type I.C.).
- Use supply wiring rated for at least 90°C.

TYPICAL SPECIFICATION

Combination unit shall be NuTone Model 765H80L.

Unit shall have steel housing finished in powder coat paint and adjustable mounting brackets.

Unit shall be rated to handle an E26 base LED bulb, 14W (max.).

Fan, heater and light shall be separately controllable. Motors shall be permanently lubricated.

Air delivery shall be no less than 80 CFM and sound level no greater than 2.0 Sones. All air and sound ratings shall be certified by HVI.

Units shall be U.L. Listed.

Suitable for use in insulated ceilings. (Type I. C.)



Broan Hartford, Wisconsin www.nutone.com 888-336-3948

REFERENCE	QTY.	REMARKS	Project
			Location
			Architect
			Engineer
			Contractor
			Submitted by Date