

REVISIONS		
REV.	DESCRIPTION	DATE
AB	Added 2" to tray and changed BA	9/27/06
AC	Changed to .875 Bearing	2/12/08
AD	Changed to 1.0325 slot, changed tray sides, added rear rubber stops	8/13/12
AE	Moved front guide bearing hole back 2"	8/16/13
AF	Moved .265x.500 slot in tray stfnr to 1.125 from 1.0625	10/16/13
AG	Changed ba and tray material (3/16)	8/24/15
AH	Update handle under tray	1/10/17

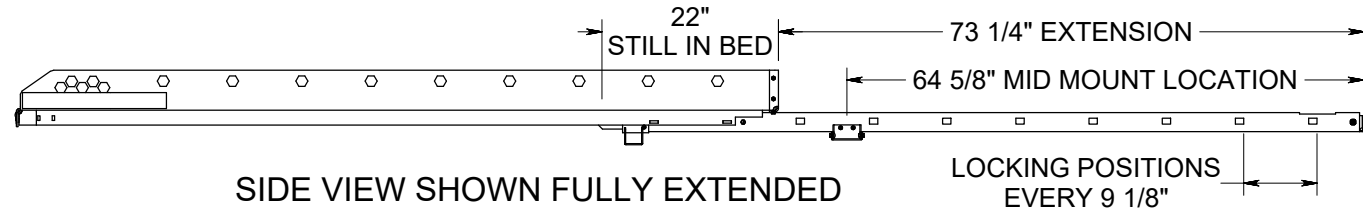

SIDE VIEW SHOWN FULLY EXTENDED

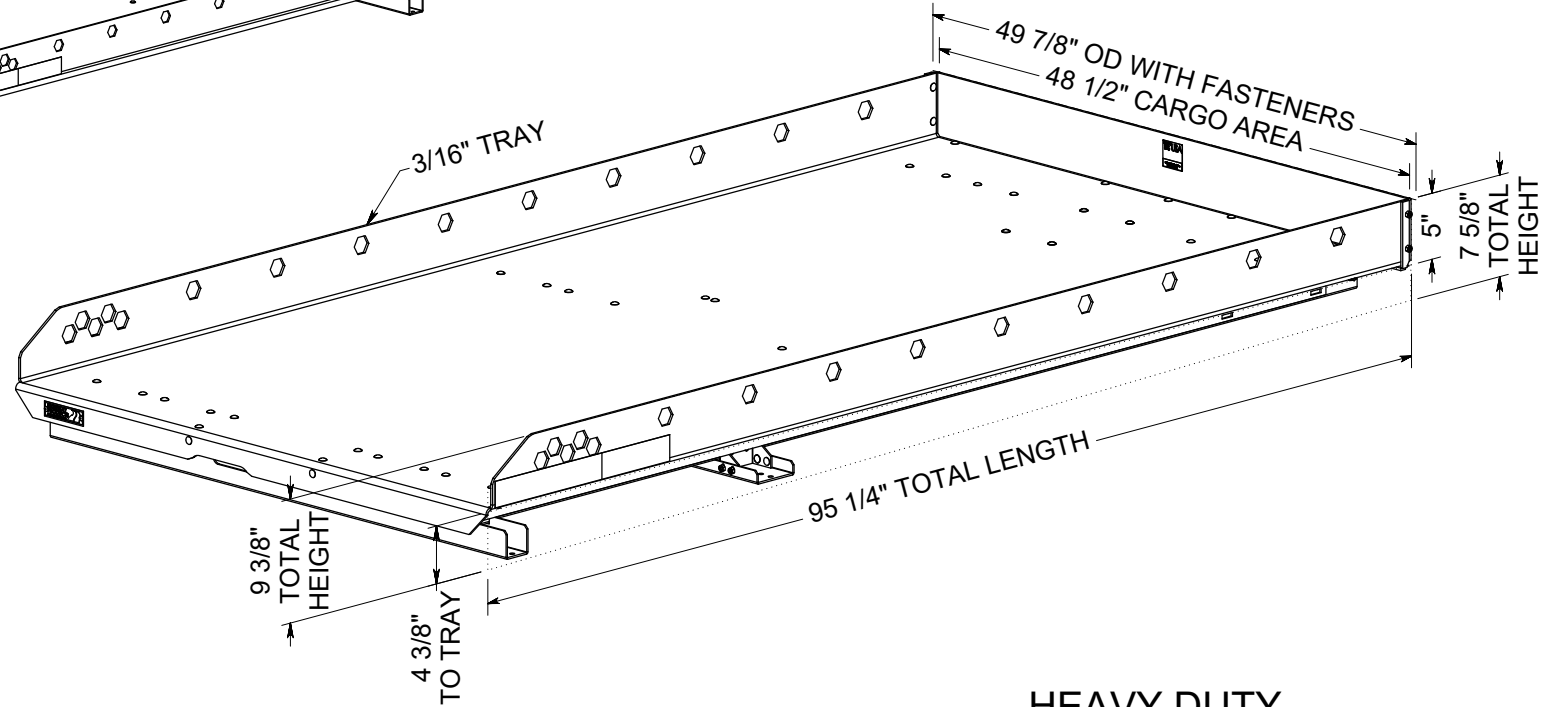
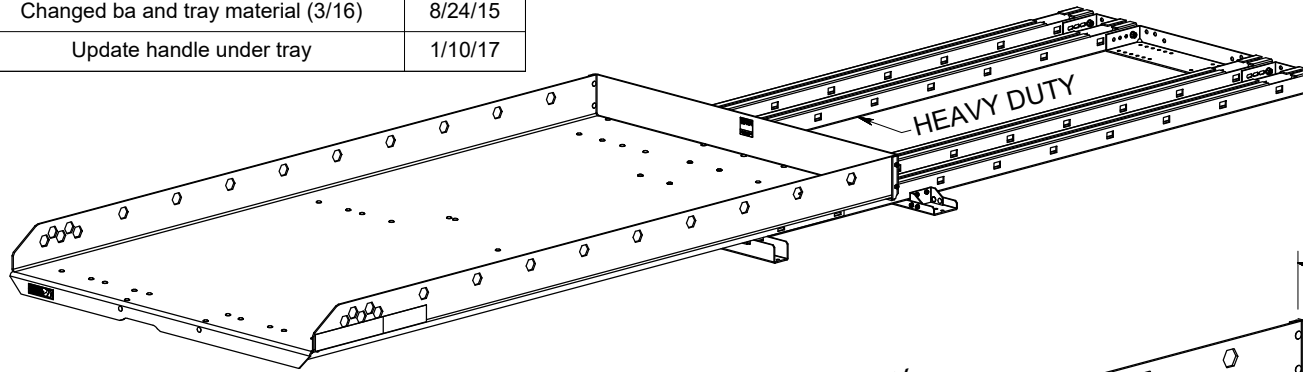

**HEAVY DUTY
TRUCK SLIDE
OVERALL DIMENSIONS
49 7/8" x 9 3/8" x 95 1/4"**

MATERIAL: AL & 10ga GALV		PROJECT #: 513
FINISH: SMOOTH		DRAWN BY: Sheldon Bywater
REVISION: AH	APVL BY: EBF	ENG DATE: 03/08/2006
Ov1	SALE BY:	TOLERANCES: ANGULAR $\pm 2^\circ$ FRACTIONAL $\pm 3/16"$ TWO PLACE DECIMAL $\pm .125$ THREE PLACE DECIMAL $\pm .0625$

SPECIAL INSTRUCTIONS:

HIGHWAY
PRODUCTS
1-800-TOOL BOX
FAX 1-800-465-9545
800TOOLBOX.COM

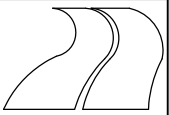

CUSTOMER:

APPROVAL SIGNATURE

YOUR PRODUCTION LEAD TIME WILL BEGIN AS SOON AS WE RECEIVE YOUR SIGNATURE APPROVAL ON THE PRINTS WITHOUT ANY REQUESTS FOR CHANGES. THANK YOU.

CUSTOMER SPECIAL INSTRUCTIONS:

PC LX FI