

OPERATION

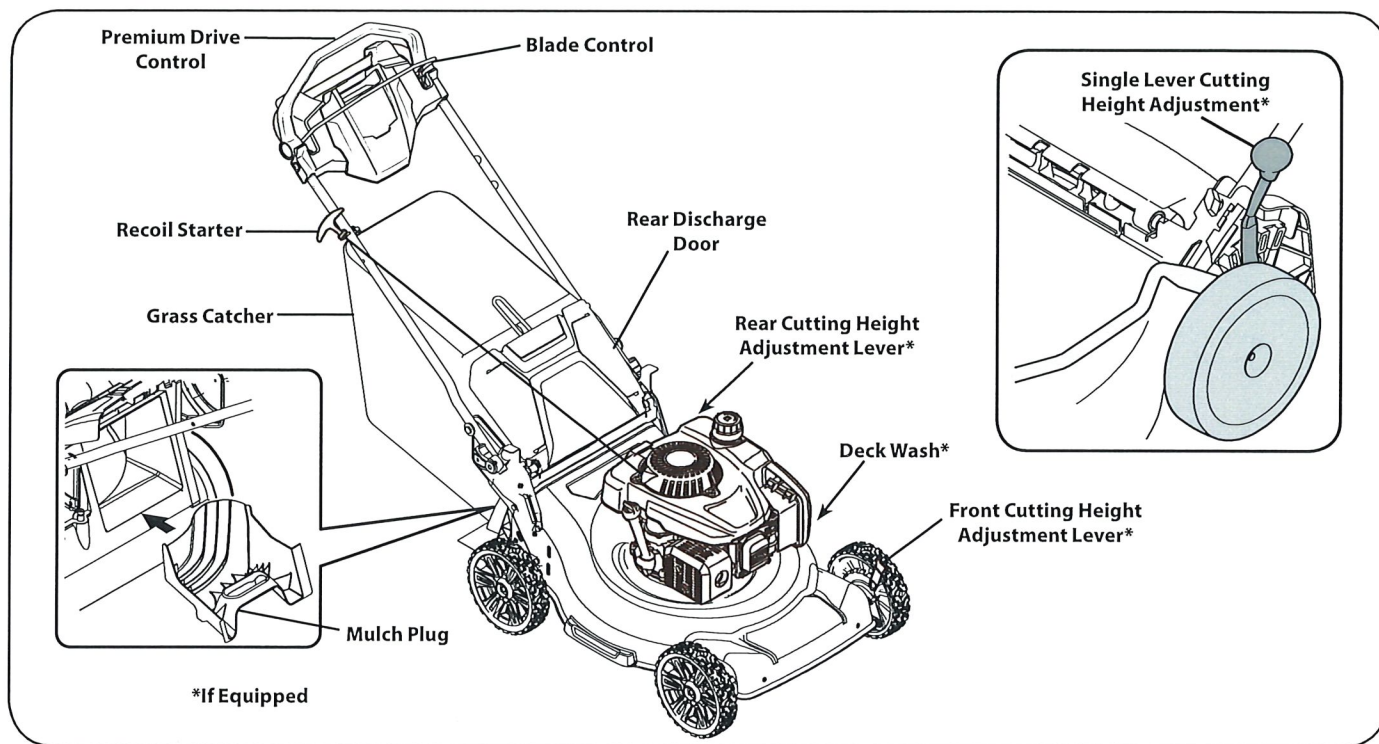

Figure 10

Blade Control

The blade control is attached to the upper handle of the mower. Depress and squeeze it against the upper handle to operate the mower. Release it to stop engine and blade.

⚠ WARNING

This blade control is a safety device. Never attempt to bypass its operation.

Premium Drive Control

The premium drive control is located on the upper handle and is used to engage the drive. Pushing the control forward will engage the drive. The farther the control is pushed forward, the faster the mower will propel. Once pressure is released from the control it will return to the neutral position and the drive will be disengaged.

Cutting Height Adjustment Lever

There are three cutting height adjustment configurations.

Single Lever

The cutting height adjustment lever is located above the rear left wheel. To adjust the cutting height, refer to Cutting Height Adjustment on page 9.

Dual Lever

The dual lever cutting height adjustment levers are located above the front and rear left wheels. To adjust the cutting height, refer to Cutting Height Adjustment on page 9.

Grass Catcher

The grass catcher, located at the rear of the mower, is used to collect the grass clippings for disposal at another site. Once the bag is full, remove it up through the handles and empty it before any further mowing.

Mulch Plug

The mulch plug is used for mulching purposes. Instead of collecting grass clippings in a grass catcher the mower has the option of recirculating the clippings back to the lawn. This is called mulching.

Trail Shield

The trail shield is attached to the rear of the mower and is there to protect the operator from flying debris. Do not use the mower unless the shield is fully functional and in place.

Recoil Starter

The recoil starter is attached to the right upper handle. Stand behind the mower and pull the recoil starter rope to start the mower.

Oil Fill Cap/Dipstick

Refer to the Engine Operator's Manual packed with your mower for detailed oil filling, checking and changing instructions.

Deck Wash (If Equipped)

Your mower's deck may be equipped with a fast attach deck wash nozzle on its surface as part of its deck wash system. Use the deck wash to rinse grass clippings from the deck's underside.

OPERATION

GAS AND OIL FILL-UP

IMPORTANT: Refer to the separate Engine Operator's Manual for additional engine information.

This mower is shipped without gasoline or oil in the engine. Be certain to service engine with gasoline and oil as instructed before starting or operating your lawn mower.

1. Add provided oil before starting mower for the first time as instructed in the separate Engine Operator's Manual.
2. Service the engine with gasoline as instructed in the separate Engine Operator's Manual.

⚠ WARNING

Be sure no one other than the operator is standing near the lawn mower while starting engine or operating mower. Never run engine indoors or in enclosed, poorly ventilated areas. Engine exhaust contains carbon monoxide, an odorless and deadly gas. Keep hands, feet, hair and loose clothing away from any moving parts on engine and lawn mower.

To Start Engine

Refer to the Engine Operator's Manual for instructions on starting and stopping the engine.

To Stop Engine

Release blade control to stop the engine and blade.

⚠ WARNING

Wait for the blade to stop completely before performing any work on the mower or to remove the grass catcher.

Using Your Lawn Mower

Be sure lawn is clear of stones, sticks, wire, or other objects which could damage lawn mower or engine. Such objects could be thrown by the blade in any direction and cause serious personal injury to the operator and helpers.

1. Once the engine is running and while continuing to hold the blade and drive controls together, push the drive control forward to propel mower. The farther the control is pushed forward, the faster the mower will propel. See Figure 11.
2. Once pressure is released from the drive control it will return to the neutral position and the mower will stop.

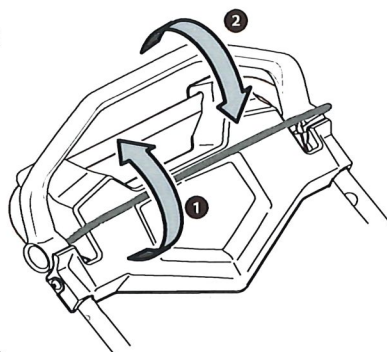

Figure 11

NOTE: For ease of use, while gripping the controls, simply lock your wrist and elbows and walk - the mower will automatically adjust to your speed.

⚠ WARNING

The operation of any lawn mower can result in foreign objects being thrown into the eyes, which can damage your eyes severely. Always wear safety glasses while operating the mower, or while performing any adjustments or repairs.

Using Mower as a Mulcher

For mulching grass, remove the grass catcher from the mower. When you remove the grass catcher from the mower, ensure the mulch plug (if equipped) is installed and allow the rear discharge door to close completely. For effective mulching, do not cut wet grass. If the grass has been allowed to grow in excess of four inches, mulching is not recommended. Use the grass catcher to collect clippings instead.

Using Mower with Grass Catcher

You can use the grass catcher to collect clippings while you are operating the mower.

1. Attach grass catcher following instructions in the Assembly section. Grass clippings will automatically collect in bag. Operate mower until grass bag is full.
2. Stop engine by releasing the blade control. Make sure that the engine has come to a complete stop.
3. Lift rear discharge door and pull grass bag up and away from the mower to remove the bag. Dispose of the grass clippings and reinstall the bag when complete.

⚠ WARNING

If you strike a foreign object, stop the engine. Disconnect the spark plug wire, thoroughly inspect mower for any damage, and repair damage before restarting and operating. Extensive vibration of mower during operation is an indication of damage. The mower should be promptly inspected and repaired.

SERVICE AND MAINTENANCE

MAINTENANCE SCHEDULE

⚠ WARNING

Before performing any type of maintenance/service, disengage all controls and stop the engine. Wait until all moving parts have come to a complete stop. Allow the engine to cool. Disconnect spark plug wire and ground it against the engine to prevent unintended starting.

Follow the maintenance schedule given below. This chart describes service guidelines for the mower only. Use the Service Log column to keep track of completed maintenance tasks. To locate the nearest Service Center or to schedule service, contact your dealer or see the service/warranty supplement packed with the mower.

IMPORTANT: See the Engine Operator's manual packed with the mower for engine specific service and maintenance schedule.

	Each use	Annually	Before Storage	Service Log
Check engine oil level	✓			
Check that all hardware is in place & secure and tight	✓	✓		
Clean grass, chaff and/or accumulated debris from around the engine, exhaust and the top of the mower.	✓			
Check blade stopping time is within 3 seconds	✓			
Lube control linkages/pivots and wheels with light oil		✓		
Clean underside of mower deck		✓		
Check mower blade and engine mounting bolt torque*		✓		
Run engine until it stops from lack of fuel, or add stabilizer to a full tank of fresh fuel prior to storage.			✓	

*Mower blade bolt torque: Min. 37.5 ft-lbs (50.8 N-m), Max. 50.0 ft-lbs (67.8 N-m). Engine mounting bolt torque: Min. 29.2 ft-lbs (39.6 N-m), Max. 41.7 ft-lbs (56.3 N-m).

TROUBLESHOOTING

⚠ WARNING

Disconnect the spark plug wire and ground it against the engine to prevent unintended starting. Before performing any type of maintenance/service, disengage all controls and stop the engine. Wait until all moving parts have come to a complete stop. Always wear safety glasses during operation or while performing any adjustments or repairs.

Problem	Cause	Remedy
Engine fails to start	<ol style="list-style-type: none"> Blade control disengaged. Spark plug boot disconnected. Fuel tank empty or stale fuel. Engine not primed (If equipped with primer). Faulty spark plug. Engine flooded. Blocked fuel line. 	<ol style="list-style-type: none"> Engage blade control. Connect wire to spark boot. Fill tank with clean, fresh gasoline. Prime engine as instructed in the Operation section. Clean, adjust gap, or replace. Wait a few minutes to restart. Contact your Parts & Repair Center to have fuel line cleaned.
Engine runs erratic	<ol style="list-style-type: none"> Spark plug boot loose. Stale fuel. Vent in gas cap plugged. Water or dirt in fuel system. Dirty air cleaner. Blocked fuel line. 	<ol style="list-style-type: none"> Connect and tighten spark plug boot. Fill tank with clean, fresh gasoline. Clear vent. Run engine until it stops from lack of fuel. Refill with fresh fuel. Refer to Air Cleaner Maintenance in the Engine Manual. Contact your Parts & Repair Center to have fuel line cleaned.
Engine overheats	<ol style="list-style-type: none"> Engine oil level low. Air flow restricted. 	<ol style="list-style-type: none"> Fill crankcase with proper oil. Clean area around and on top of engine.
Occasional skips (hesitates)	<ol style="list-style-type: none"> Spark plug gap too close. 	<ol style="list-style-type: none"> Adjust gap. Refer to Spark Plug Maintenance in Engine Manual.
Idles poorly	<ol style="list-style-type: none"> Spark plug fouled, faulty, or gap too wide. Dirty air cleaner. 	<ol style="list-style-type: none"> Reset gap or replace spark plug. Refer to Air Cleaner Maintenance in the Engine Manual.

SERVICE AND MAINTENANCE

Problem	Cause	Remedy
Excessive vibration	<ol style="list-style-type: none"> 1. Cutting blade loose or unbalanced. 2. Bent cutting blade. 	<ol style="list-style-type: none"> 1. Tighten blade and adapter. Balance blade. 2. Replace blade.
Mower will not mulch grass	<ol style="list-style-type: none"> 1. Wet grass. 2. Excessively high grass. 3. Dull blade. 	<ol style="list-style-type: none"> 1. Do not mow when grass is wet; wait until later to cut. 2. Mow once at a high cutting height, then mow again at desired height or make a narrower cutting path. 3. Sharpen or replace blade.
Uneven cut	<ol style="list-style-type: none"> 1. Wheels not positioned correctly. 2. Dull blade. 	<ol style="list-style-type: none"> 1. Adjust cutting height lever on right front and right rear wheel to same position. 2. Sharpen or replace blade.
Mower will not self propel	<ol style="list-style-type: none"> 1. Belt not installed properly. 2. Debris clogging drive operation. 3. Damaged or worn belt. 	<ol style="list-style-type: none"> 1. Check belt for proper pulley installation and movement. 2. Stop engine, disconnect spark plug boot, and clean out debris. 3. Inspect and, if necessary, see your Parts & Repair Center to have belt replaced.

General Recommendations

- Always observe safety rules when performing any maintenance.
- The warranty on this lawn mower does not cover items that have been subjected to operator abuse or negligence. To receive full value from warranty, operator must maintain the mower as instructed here.
- Changing of engine-governed speed will void engine warranty.

Lubrication

Blade Control

Lubricate pivot points on the blade control at least once a season with light oil. This control must operate freely in both directions. See Figure 12.

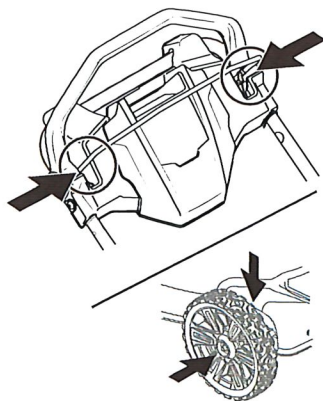

Figure 12

Wheels

Lubricate all wheel hubs/axles at least once a season with light oil. See Figure 12.

Engine Maintenance

Refer to the Engine Operator's Manual packed with your mower for a detailed description of all engine-related service specifications.

Clean Engine

- Daily or before every use, clean grass, chaff or accumulated debris from engine. Keep linkage, spring, and controls clean. Keep area around and behind muffler free of any combustible debris.
- Keeping engine clean allows air movement around engine.
- Engine parts should be kept clean to reduce the risk of overheating and ignition of accumulated debris.

⚠ CAUTION

Do not use water to clean engine parts. Water could contaminate fuel system. Use a brush or dry cloth.

Mower Maintenance

Deck Wash (If Equipped)

Your mower's deck may be equipped with a deck wash system. Use the deck wash to rinse grass clippings from the deck's underside and prevent the buildup of corrosive chemicals. Complete the following steps AFTER EACH MOWING:

1. Push the mower to a level, clear location on your lawn. Ensure your garden hose can reach your mower.

⚠ CAUTION

Make certain the mower's discharge chute is directed AWAY from your house, garage, parked cars, etc.

2. Remove the fast attach deck wash nozzle from the mower deck and thread it onto the end of your garden hose.
3. Attach garden hose with the deck wash nozzle to the water port on your deck's surface. See Figure 13.
4. Turn the water ON.
5. Start the engine as described in the Engine Operator's Manual.
6. Run the engine for a minimum of two minutes, allowing the underside of the cutting deck to thoroughly rinse.
7. Release blade control to stop the engine and blade.
8. Turn the water OFF and detach the deck wash nozzle from the water port on your deck's surface.
9. After cleaning your deck, restart the mower. Keep the engine and blade running for a minimum of two minutes, allowing the underside of the cutting deck to thoroughly dry.

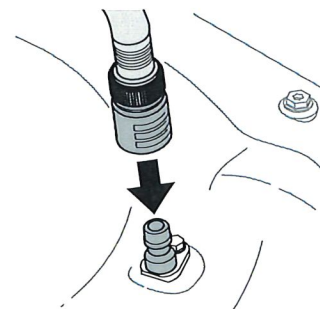

Figure 13

SERVICE AND MAINTENANCE

Deck Cleaning

At least once a season clean the underside of the mower deck to prevent build-up of grass clippings or other debris.

1. Allow the engine to run until it is out of fuel. Do not attempt to pour fuel from the engine. Disconnect spark plug wire. Refer to Engine Operator's Manual.
2. Turn mower on its side keeping the muffler side down and making sure that the air filter and the carburetor are facing up. Hold mower firmly.
3. Scrape and clean the underside of the deck with a suitable tool. Do not spray with water.

IMPORTANT: Do not use a pressure washer or garden hose to clean your mower. These may cause damage to bearings, or the engine. The use of water will result in shortened life and reduce serviceability.

4. Put the mower back on its wheels on the ground.

Drive Adjustment

The drive system consists of pulleys, a belt, and a cable linking the transmission to the drive control. As these components wear, adjustment may be needed. To adjust the drive perform the following:

1. Weak drive. See Figure 14 -
 - a. Loosen jam nut (a).
 - b. Thread adjustment nut (b) down, towards the mower base to lengthen the drive cable.
 - c. Securely tighten jam nut.
2. Drive control is tight or difficult to pull back. See Figure 15 -
 - a. Loosen jam nut (a).
 - b. Thread adjustment nut (b) up, towards the handle to shorten the drive cable.
 - c. Securely tighten jam nut.

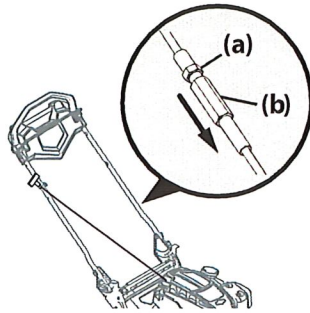

Figure 14

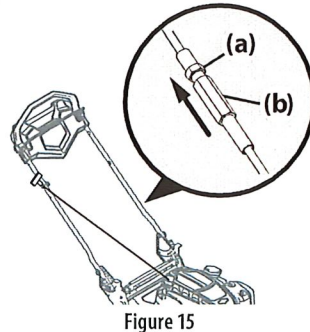

Figure 15

Blade Care

⚠ WARNING

When removing the cutting blade for sharpening or replacement, protect your hands with a pair of heavy gloves or use a heavy rag to hold the blade.

Periodically inspect the blade adapter for cracks, especially if you strike a foreign object. Replace when necessary. Follow the steps below for blade service.

1. Allow the engine to run until it is out of fuel. Do not attempt to pour fuel from the engine.
2. Disconnect spark plug wire. Refer to Engine Operator's Manual.
3. Turn mower on its side keeping the muffler side down and making sure that the air filter and the carburetor are facing up.
4. Remove bolt (a) and blade bell support (b) which hold the blade and the blade adapter to the engine crankshaft. See Figure 16.
5. Remove blade (c) and adapter (d) from the crankshaft. See Figure 16.

6. Remove blade from the adapter for testing blade balance.
 - a. Balance the blade on a round shaft screwdriver to check.
 - b. Remove metal from the heavy side until it balances evenly.

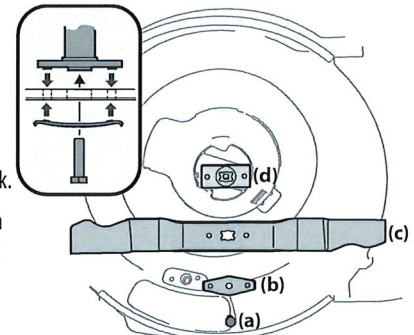

Figure 16

NOTE: When sharpening the blade, follow the original angle of grind. Grind each cutting edge equally to keep the blade balanced.

⚠ WARNING

An unbalanced blade will cause excessive vibration when rotating at high speeds. It may cause damage to engine and blade could break causing personal injury.

7. Lubricate the engine crankshaft and the inner surface of the blade adapter with light oil. See Figure 16 inset.
 - a. Slide the blade adapter (d) onto the engine crankshaft.
 - b. Place the blade on the adapter such that the side of the blade marked "Grass Side" (or with part number) faces the ground when the mower is in the operating position.
 - c. Make sure that the blade is aligned and seated on the blade adapter flanges.
8. Place blade bell support (b) on the blade (c). Align notches on the blade bell support with small holes in blade.
9. Replace hex bolt (a) and tighten hex bolt to torque: Min. 37.5 ft-lbs (50.8 N-m), Max. 50.0 ft-lbs (67.8 N-m).

NOTE: To ensure safe operation of your mower, periodically check the blade bolt for correct torque.

Belt Care

NOTE: Several components must be removed in order to change the mower's self-propulsion drive belt. See an authorized Service Center to have your belt replaced.

Off-Season Storage

The following steps should be taken to prepare your lawn mower for storage.

- Clean and lubricate mower thoroughly as described in Lubrication section on page 13.
- Apply a coat of chassis grease to mower's cutting blade to prevent rusting.
- Refer to Engine Operator's Manual for correct engine storage instructions.
- Do not use a pressure washer to clean your mower.
- Store mower in a dry, clean area. Do not store next to corrosive materials, such as fertilizer.

When storing any type of power equipment in a poorly ventilated or metal storage shed, care should be taken to rust-proof the equipment. Using a light oil or silicone, coat the equipment, especially cables and all moving parts of your lawn mower before storage.