

OPERATOR'S MANUAL

KUBOTA EXCAVATOR

MODEL K008-3

T4
TIER

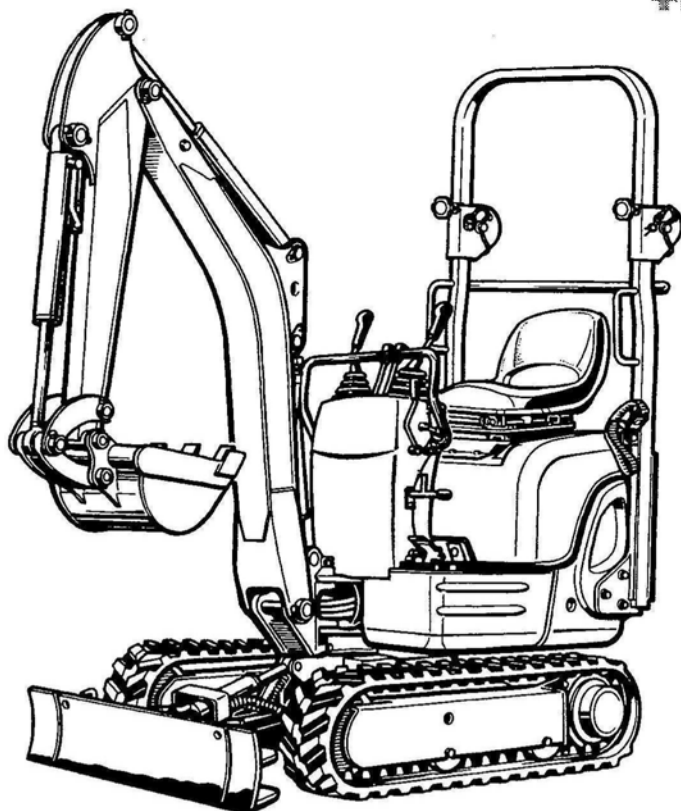

L-5013

READ AND SAVE THIS MANUAL

Kubota

LIST OF ABBREVIATIONS

Abbreviations	Description
API	American Petroleum Institute
ASTM	American Society for Testing and Materials, USA
DIN	German Institute for Standards, Federal Republic of Germany
Front	"Front" means the front view towards the boom and dozer
ISO	International Standards Organization
JIS	Japanese Industrial Standard
L	Volume (Litre)
L/min	Litre per minute
MIL	Military Standards
rpm	Revolutions Per minute
SAE	Society of automotive Engineering
ROPS	Roll-Over Protective Structures

GENERAL SYMBOLS

The instruments and operation elements have been marked with a series of symbols in order to simplify the operation of your excavator. These symbols are listed below with the respective descriptions.

	Safety alert Symbol		Boom swing (left)
	Alarm lamp "Fuel level too low"		Boom swing (Right)
	Alarm lamp "Engine oil pressure"		Dozer raise
	Alarm lamp "Water temperature warning"		Dozer lower
	Alarm lamp "Battery charge"		Operation direction of control lever
	Horn		Operation direction of control lever
	Diesel		Read operator's manual
	Hydraulic fluid		Lock
	Fast		Unlock
	Slow		Reducing / Increasing track width
	Excavator - Overhead movement toward the front		
	Excavator - Overhead movement toward the rear		
	Boom raise		
	Boom lower		
	Arm out		
	Arm in		
	Bucket dig / rollback		
	Bucket dump		

FOREWORD

You are now the proud owner of a KUBOTA excavator. This excavator is a product of KUBOTA quality engineering and manufacturing. It is made of quickly fine materials and under rigid quality control systems. It will give you long, satisfactory service. To obtain the best use of your excavator, please read this manual carefully. It will help you become familiar with the operation of the excavator and contains many helpful hints about excavator maintenance. It is KUBOTA's policy to utilize as quick as possible every advance in our research. The immediate use of new techniques in the manufacture of products may cause some small parts of this manual to be outdated. KUBOTA distributors and dealers will have the most up-to-date information. Please do not hesitate to consult with them.

SAFETY FIRST

This symbol, the industry's "Safety Alert Symbol", is used throughout this manual and on labels on the machine itself to warn of the possibility of personal injury. Read these instructions carefully. It is essential that you read the instructions and safety regulations before you attempt to assemble or use this unit.



DANGER : Indicates an imminently hazardous situation which, if not avoided, will result in death or serious injury.



WARNING : Indicates a potentially hazardous situation which, if not avoided, could result in death or serious injury.



CAUTION: Indicates a potentially hazardous situation which, if not avoided, may result in minor or moderate injury.

IMPORTANT : Indicates that equipment or property damage could result if instructions are not followed.

NOTE : Gives helpful information.

CONTENTS

▲ SAFE OPERATION	1
DEALER SERVICE	11
TECHNICAL DATA	12
Operating Instructions	
DESCRIPTION OF MACHINE PARTS	13
INSTRUMENT PANEL AND CONTROL ELEMENTS	14
BEFORE START	16
HANDLING THE SAFETY DEVICES	16
DAILY CHECKS	16
OPERATION OF THE ENGINE	17
STARTING THE ENGINE	17
STARTING THE ENGINE UNDER COLD CONDITIONS	19
STOPPING THE ENGINE	20
STARTING WITH AN AUXILIARY BATTERY	20
EXCAVATOR OPERATION	22
CONTROL OBSERVATIONS DURING OPERATION	22
RUNNING-IN OF THE NEW EXCAVATOR	22
STARTING	23
CONTROLS FOR ATTACHMENTS	24
OPERATION OF THE BOOM	27

OPERATION OF THE ARM	28
OPERATION OF BUCKET	28
SWIVEL (UNIT SWING) OPERATION	29
BOOM SWING OPERATION	29
BOOM SWING PEDAL	30
OPERATION OF TRACK WIDTH CHANGE AND DOZER	30
DRIVING	32
TURNS	33
UP AND DOWNHILL TRAVELLING	35
PARKING ON A SLOPE	36
DRIVE SPEED PEDAL	36
SERVICE PORT OPERATION	36
IMPORTANT INFORMATION ON EXCAVATOR OPERATION ..	37

TRANSPORTING THE EXCAVATOR ON A TRUCK	38
--	-----------

LIFTING OF THE EXCAVATOR	40
---------------------------------------	-----------

Care and Maintenance

MAINTENANCE	42
MAINTENANCE INTERVALS	42
OPENING AND CLOSING OF PARTS	44
DAILY CHECKS	44
REGULAR CHECKS AND MAINTENANCE WORK	49
EVERY 50 SERVICE HOURS	49
EVERY 100 SERVICE HOURS	51

EVERY 200 SERVICE HOURS	52
EVERY 500 SERVICE HOURS	54
EVERY 1000 SERVICE HOURS ...	54
EVERY 1000 SERVICE HOURS OR ONCE A YEAR	56
EVERY 1500 SERVICE HOURS ...	56
EVERY 2000 SERVICE HOURS ...	56
EVERY 3000 SERVICE HOURS ...	56
ANNUAL SERVICING	56
BIENNIAL SERVICING	56
OTHER SERVICING	58
OTHER ADJUSTMENTS AND REPLACEMENTS	59
PURGING OF THE FUEL SYSTEM	59
ADJUSTMENT OF CRAWLERS	59
CHANGING THE BUCKET	61
FUSES	61
TROUBLESHOOTING	62
OPERATION IN COLD WEATHER CONDITIONS	64
PREPARATION FOR OPERATION IN COLD WEATHER	64
PROCEDURE AFTER WORK CARRIED OUT	64
LONG STORAGE	65
RECOMMENDED OILS	67
MAIN DIMENSIONS	68
LIFTING CAPACITY	69

SAFE OPERATION

The best insurance against accidents is to abide by the safety regulations.

Read and understand this section carefully, before operating the excavator.

Every user, however experienced, should carefully read and understand this section and those of the attachments and accessories before taking the excavator into operation. The owner is obliged to inform the operators of these instructions in detail. Keep this manual in the toolbox.

1. BEFORE OPERATION

1. Make yourself acquainted with the excavator and be aware of its limits. Read this operator's manual carefully before starting the excavator.
2. Obey the danger, warning and caution labels on the machine.
3. For your safety, ROPS (Roll-Over Protective Structure) with a seat belt is installed. Always use seat belt when the machine is equipped with a ROPS. Do not modify structural members of ROPS by welding, drilling, bending, grinding or cutting, as this may weaken the structure. If any component is damaged, replace it. Do not attempt repairs. If ROPS is loosened or removed for any reason, make certain all parts are reinstalled correctly. Tighten mounting bolts to proper torque.
4. The seat belt must be inspected regularly and replaced if damaged.

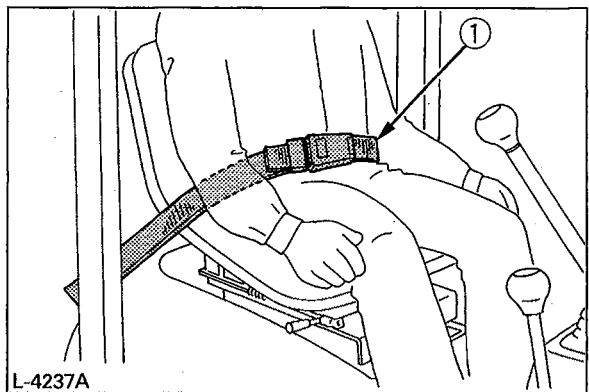

L-4237A

(1) Seat belt

5. Track can be set at the narrow width 700mm and the standard width 860mm. (for details see "OPERATION OF TRACK WIDTH CHANGE AND DOZER")

Do not operate in narrow track width 700mm, there is a risk of the excavator tipping over, always operate in standard track width 860mm, except to pass through a narrow space on even ground.

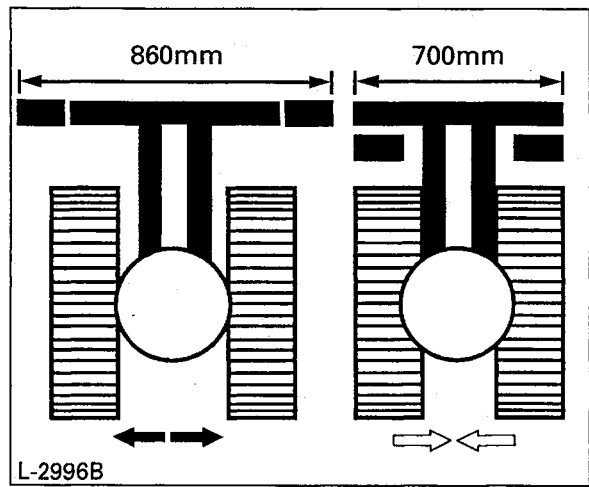

L-2996B

6. Do not use the excavator under the influence of alcohol, medication or other substances. Fatigue is also dangerous.
7. Check the surroundings carefully before using the excavator or when attachments are being attached.
 - Pay attention to the overhead clearance with electric wires.

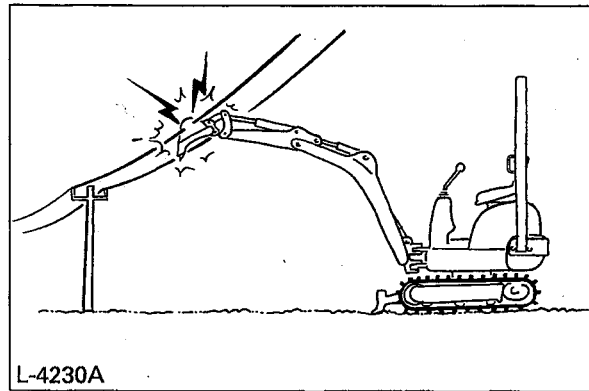

L-4230A

- Check for pipes and buried cables.
- Check for hidden holes, hindrances, soft ground and overhangs.

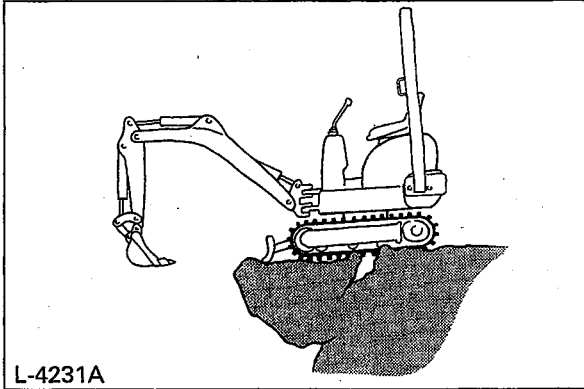

- During excavator use do not allow any persons within the working range.
- 8. Do not allow other persons to use the machine before having informed him on the exact operation and work instructions, and be assured that the operator's manual has been read and understood.
- 9. Do not wear baggy, torn or too large clothing when working with the excavator. Clothing can get caught in rotating parts or control elements which can cause accidents or injuries. Wear adequate safety clothing, e.g. safety helmet, safety shoes, eye protection, ear protection, working gloves, etc., as necessary and as prescribed by laws or statutes.

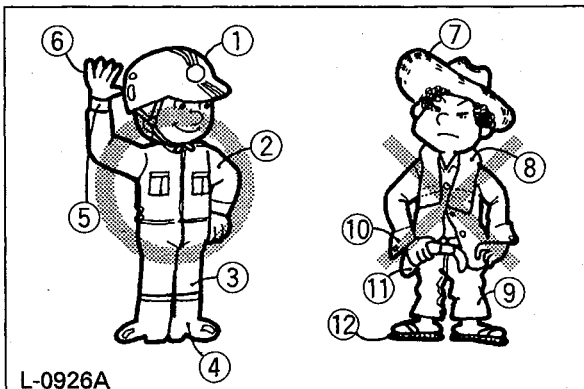

- (1) *Helmet*
- (2) *Clothing fit for work*
- (3) *Tight seams*
- (4) *Good grip footwear*
- (5) *Well fitting cuffs*
- (6) *Working gloves*
- (7) *Straw hat*
- (8) *Towel*
- (9) *Baggy trousers*
- (10) *Loose cuffs on shirt*
- (11) *Baggy shirt*
- (12) *Rubber sandals*

- 10. Do not allow passengers to get on any part of the excavator seat during operation.
- 11. Check mechanical parts for correct adjustments and wear. Exchange worn or damaged parts immediately. Check nuts and bolts regularly for tight fitment. (for details see "Care and Maintenance").
- 12. Keep your excavator clean. Heavy soiling, grease, dust and grass can inflame and cause accidents or injuries.
- 13. Use only KUBOTA authorized attachments.
- 14. Before starting the excavator, be absolutely sure that the excavator has been filled with fuel, lubricated, greased and undergone other maintenance work.
- 15. Do not modify the excavator, otherwise it could lead to unforeseen safety problems.

2. STARTING OF THE EXCAVATOR

- 1. Get into and out of the machine safely. Always face the machine. Always use handrails and available steps and keep yourself well balanced. Do not hold any of the control levers and switches. Do not jump on or off the machine, whether stationary or in motion.
- 2. Start and control the excavator only from the operator's seat. The driver should not lean out of his seat when the engine is running.
- 3. Before starting the engine, make sure that all control levers (including auxiliary control levers) are in their neutral positions.
- 4. Do not start the engine by jumping the starter connections. Do not try to circumvent using the starter switch, otherwise the engine could start suddenly and the excavator could move.

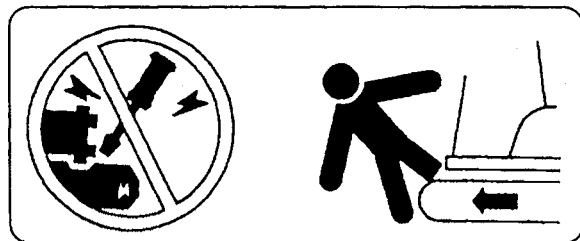

5. Make sure that the dozer is on the front side. (The dozer must be raised.) If the swing frame has been turned 180°, i.e. the dozer is, seen from the operator, "behind", then the travel direction is opposite to the drive direction of the levers (when activating the drive lever forwards, the excavator, seen from the operator, will move backwards).

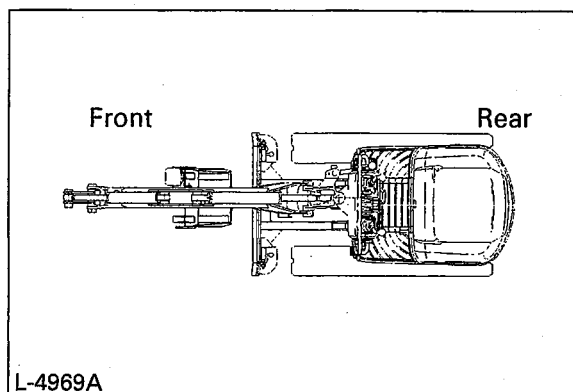

L-4969A

6. Do not run the engine in closed or badly ventilated rooms. Carbon monoxide is colourless, odourless and deadly.

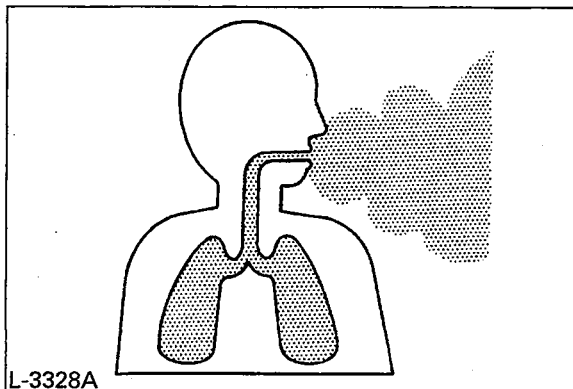

L-3328A

7. Keep all safety equipment and covers in place. Replace damaged or missing safety devices.
8. Precautions against tipping over. In order to secure safe operation, keep away from steep slopes and embankments. Do not swing the bucket downwards. Lower the dozer during digging. Keep the bucket as low as possible while driving upwards. Turn slowly on slopes. Do not keep the excavator near the edges of trenches and banks, as the earth can give way due to the weight of the excavator.
9. Watch out at all times where the excavator is being moved to. Keep an eye out for hindrances.
10. Keep enough distance from trench and bank edges.

◆ Safety for children

Tragedy can occur if the operator is not alert to the presence of children. Children generally are attached to machines and the work they do.

11. Never assume that children will remain where you last saw them.
12. Keep children out of the work area and under the watchful eye of another responsible adult.
13. Be alert and shut your machine down if children enter the work area.
14. Never carry children on your machine. There is no safe place for them to ride. They may fall off and be run over or interfere with your control of the machine.
15. Never allow children to operate the machine even under adult supervision.
16. Never allow children to play on the machine or on the implement.
17. Use extra caution when backing up, look behind and down-make sure area is clear before moving.
18. When parking your machine if at all possible park on a firm, flat and level surface; if not, park across a slope. Set the parking brake(s), lower the implements to the ground, remove the key from the ignition and lock the cab door (if equipped) and chock the crawlers or the wheels.

3. AFTER OPERATION

Before leaving the machine,

- Bring the excavator to hard even ground.
- Lower the attachments and the dozer blade on the ground.
- Stop the engine.
- Lock all control levers.
- Remove the key.

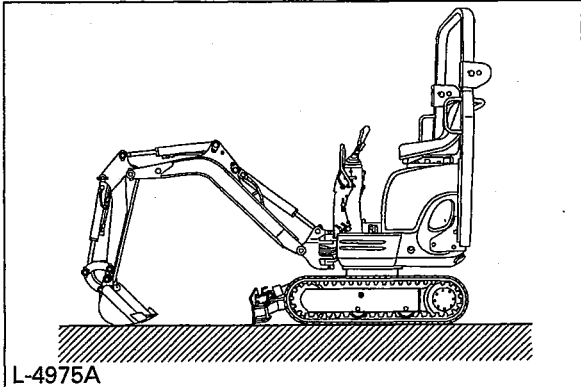

L-4975A

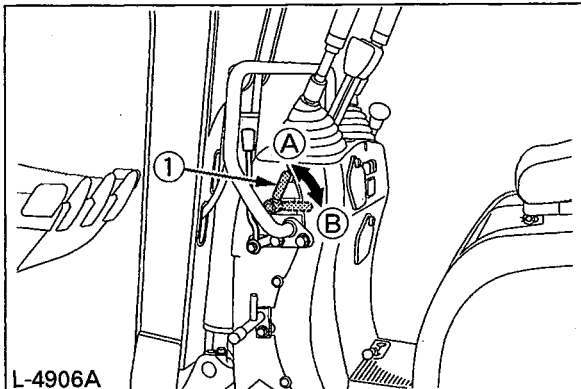

L-4906A

(1) Lock lever

(A) "Lock"

(B) "Unlock"

4. SAFE LOADING AND TRANSPORT OF THE EXCAVATOR

1. Observe all regulations concerning the transport of excavators on public roads.
2. Use adequately long and robust ramps when loading on a truck. (for details see "TRANSPORTING THE EXCAVATOR ON A TRUCK")
3. Do not change the running direction and to avoid a tipping over, do not try to swing the attachment crosswise to the loading ramps.
4. After loading of the excavator on a truck, engage the swing lock pin. Lower the attachment on the loading plane and release the pressure from the hydraulic system. Block the crawlers with blocks and wire down the excavator. After loading the excavator on a truck, tie down the undercarriage of the excavator with a strong steel wire on the truck.

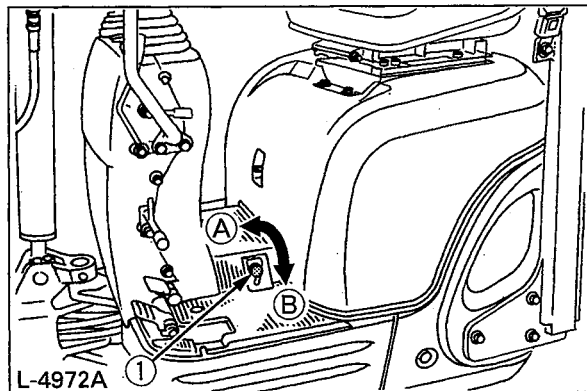

L-4972A

(1) Swing lock pin

(A) "Unlock"

(B) "Lock"

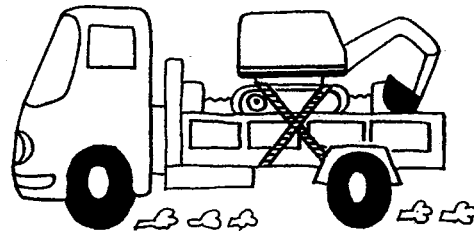

L-4200A

5. Do not brake abruptly with the excavator loaded. Fatal accidents could happen.

6. If the excavator is to tow another machine, the load must be smaller than the strength of the hook.

Max. drawbar pull at coupling hook	35.3 kN
Max. vertical load at coupling hook	4.1 kN

5. MAINTENANCE

Before doing maintenance work on the excavator, place the machine on even solid ground, lower the attachments on the ground, stop the engine and release the cylinder pressure by actuating the levers. When dismantling hydraulic parts, make sure that the hydraulic oil has cooled down sufficiently to avoid burns.

Start maintenance work carefully, e.g. loosen screws slowly so that oil will not squirt out.

1. Before doing work on the engine, the exhaust system, the radiator and the hydraulics, let the excavator cool down sufficiently.
2. Turn off the engine at all times when filling with fuel. Avoid spilling and over-filling of fuel.
3. Smoking is prohibited while fuelling and handling the battery! Keep sparks and fire away from the fuel tank and battery. Flammable gases escape from the battery, especially during charging.
4. Do not use or charge the refillable type battery if the fluid level is below the LOWER (lower limit level) mark. Otherwise, the battery component parts may prematurely deteriorate, which may shorten the battery's service life or cause an explosion. Check the fluid level regularly and add distilled water as required so that the fluid level is between the UPPER and LOWER levels.
5. Read and follow "STARTING WITH AN AUXILIARY BATTERY" in "OPERATION OF THE ENGINE", when starting with an auxiliary battery.
6. To avoid short-circuiting the battery, always remove the earth cable first and attach the plus cable first.
7. Keep a first-aid box and a fire extinguisher at hand at all times.

8. Do not open the radiator cap before the radiator has cooled down sufficiently. First loosen the cap to the first stop and allow the system enough time to release the remaining pressure. Then loosen the cap completely.
9. Leaking hydraulic fluid has enough pressure to penetrate the skin and cause serious injuries. Leakages from pin holes can be totally invisible. Do not use the bare hand for checking on possible leakages. Always use a piece of wood or cardboard. It is strongly recommended you use a face mask or eye protection. Should injuries occur with leaking hydraulic fluid, contact a doctor immediately. This fluid can cause gangrene or serious allergic reactions.

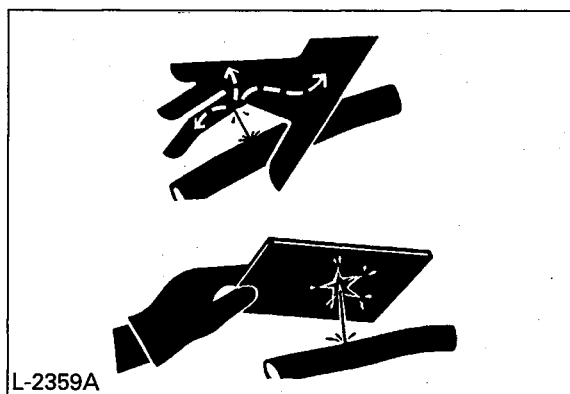

10. To avoid leakage of battery acid which contains heavy metals, do not throw the battery away.
11. Observe all laws and regulations concerning the disposal of used oil, coolants, solvents, hydraulic fluids, battery acids and batteries.
12. To avoid fire, do not heat the hydraulic components (tanks, pipes, hoses, cylinders) before they have been drained and washed.

13. Use a face mask or eye protection to protect the eyes and respiratory system against dust and other foreign particles.

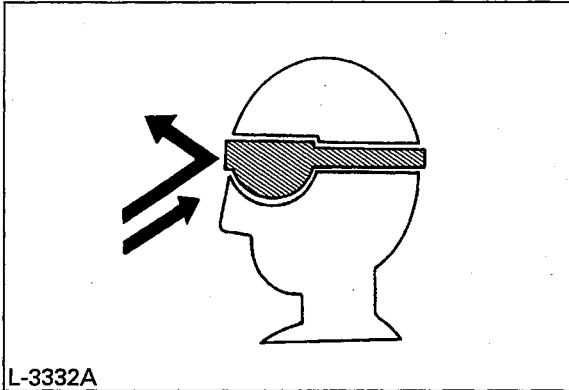

14. Do not crawl under the excavator if the excavator is only supported by the boom and arm or the dozer. The excavator can tip over or lower itself due to hydraulic pressure loss. Always use safety struts or other appropriate supports.
15. KUBOTA uses no parts which are lined with asbestos. Do not use these kind of parts even if they can be installed.

6. DANGER, WARNING AND CAUTION LABELS

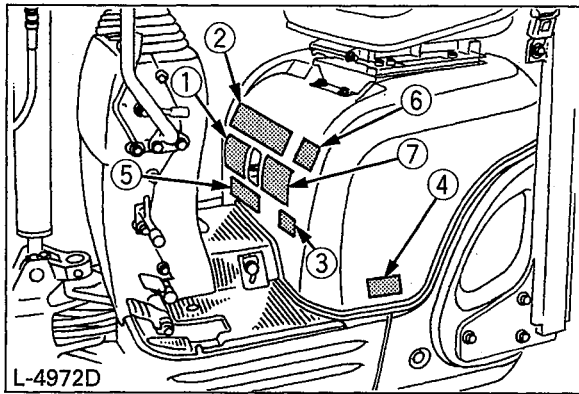

- ① Part No. RC108-5718-1
 Start the engine only from the operator's seat.
 Do not start the engine by jumping the starter connections.

	⚠ DANGER
	<p>TO AVOID PERSONAL INJURY OR DEATH FROM A MACHINE RUNAWAY.</p> <p>1. Do not start engine by shorting across starter terminals.</p> <p>2. Start engine only from operator's seat.</p>

- ② Part No. 69198-5773-2

⚠ CAUTION
<p>TO AVOID PERSONAL INJURY:</p> <ol style="list-style-type: none"> 1. Read and understand operator's manual before attempting to start or operate the excavator. 2. Before starting the engine, make sure all control levers are in neutral and the operating area is clear of all bystanders. 3. Never allow passengers on any part of the excavator while operating. 4. Know your work area before starting operation. <ul style="list-style-type: none"> ● Check underground lines and cables. ● Stay off slopes too steep for safe operation. ● Check overhead clearance with electric wires. ● Check for hidden holes, obstacles or drop-offs and overhangs. 5. Make sure all shields are in place and securely fastened. 6. Before dismantling from the excavator, lower all attachment to the ground, stop the engine and remove the key. 7. Before storing or transporting the excavator, install the swing lock pin.

- ③ Part No. 69198-5717-1

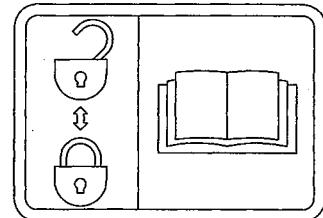

- ④ Part No. RD148-5736-1
 Diesel fuel only No fire

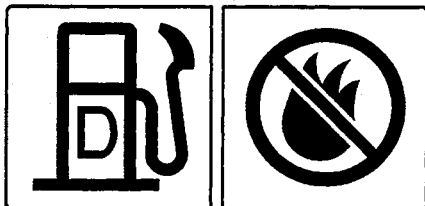

**LOW SULFUR FUEL OR
 ULTRA LOW SULFUR
 FUEL ONLY**

- ⑤ Part No. 69198-5774-1
 Before moving the excavator,
KNOW THE LOCATION OF THE DOZER BLADE.

⚠ WARNING
<p>TO AVOID PERSONAL INJURY OR DEATH: Before moving the excavator, KNOW THE LOCATION OF THE DOZER BLADE. The excavator will travel in the direction of the dozer blade when steering levers are moved away from the operator</p>

- ⑥ Part No. 69198-5778-1

⚠ CAUTION
<p>Maintain a three point contact with the steps and handrails.</p>

- ⑦ Part No. 69198-5777-1

⚠ CAUTION	
<p>TO AVOID PERSONAL INJURY: Do not open engine hood before stopping engine. Only when engine does not stop by key, open engine hood and push the stop lever back and hold it until the engine stops.</p>	

Do not open the engine bonnet before stopping the engine.

[Not Two Pattern Selection Type]

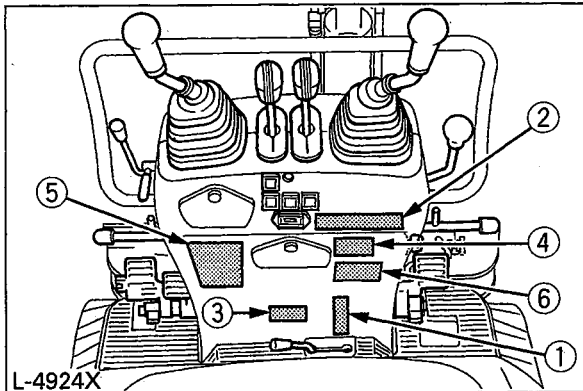

[Two Pattern Selection Type]

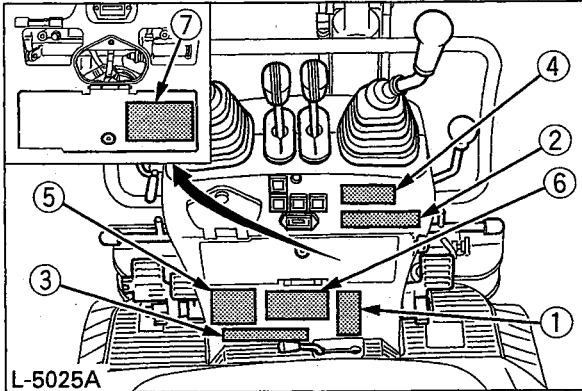

① Part No. RA118-5776-1
Do not stick your toes out of foot step.

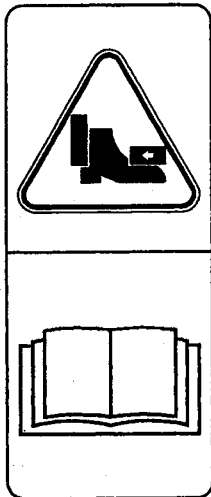

② Part No. 69198-5772-1

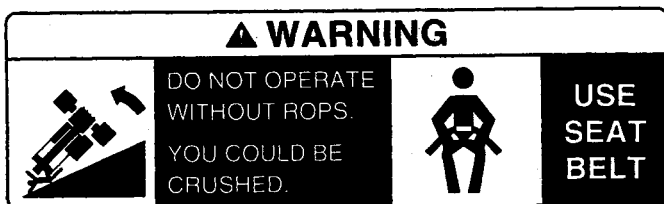

③ Part No. 69198-5784-1
Read and understand operator's manual before attempting to start or operate the excavator.

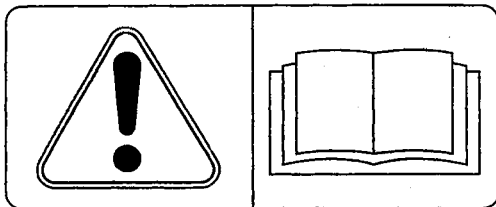

④ Part No. 69198-5771-1

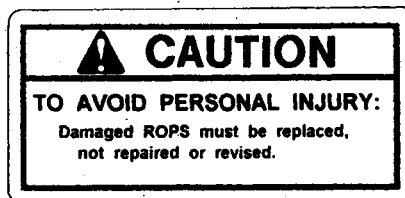

⑤ Part No. 69198-5763-1

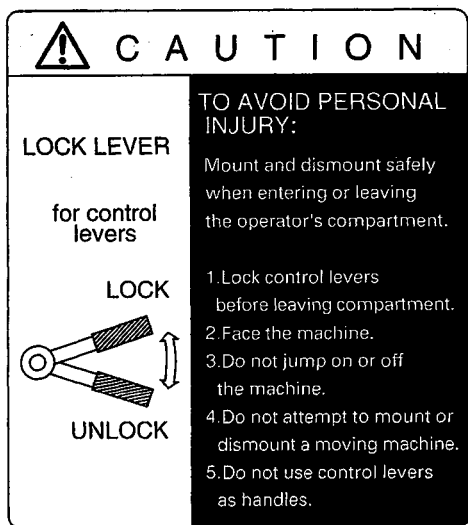

⑥ Part No. 69198-5776-1

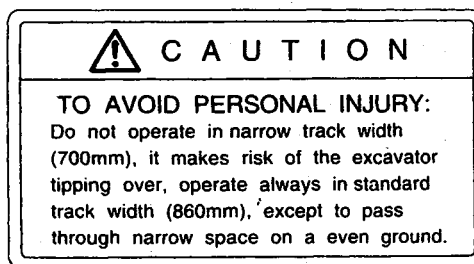

⑦ Part No. RA028-5793-1

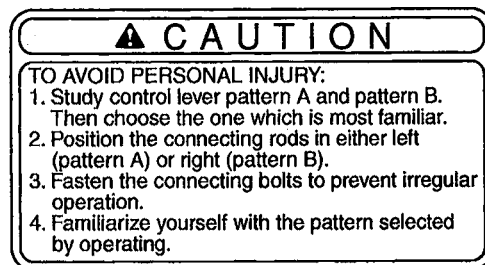

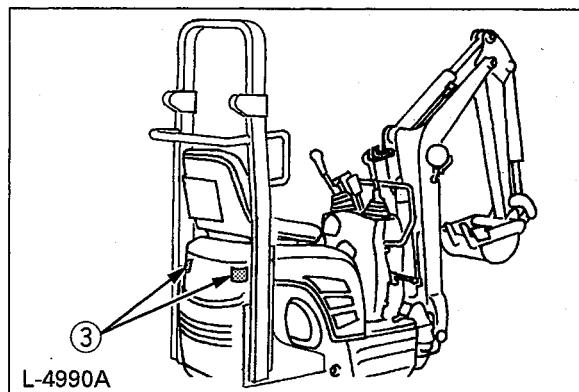
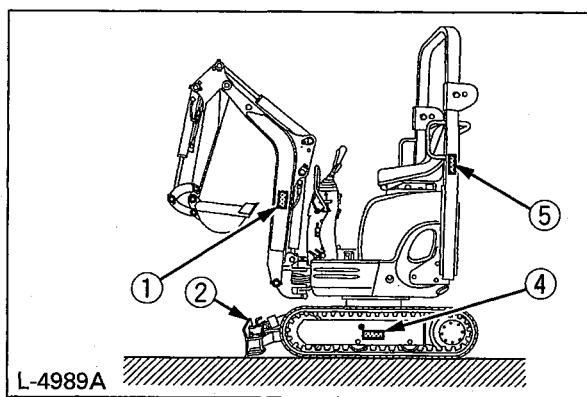

① Part No. 68328-5735-1

[Both sides]

Do not enter into the boom swing area.

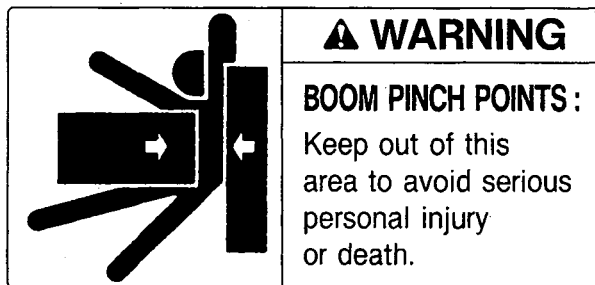

② Part No. RC108-5796-1

[Both sides]

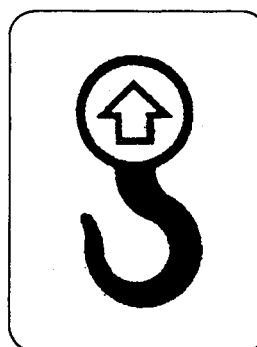

③ Part No. RA028-5728-1

[Both sides]

Do not allow any persons within the working range.

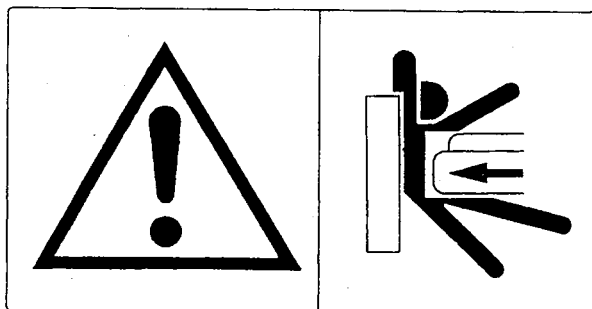

⑤ Part No. RA028-4514-1

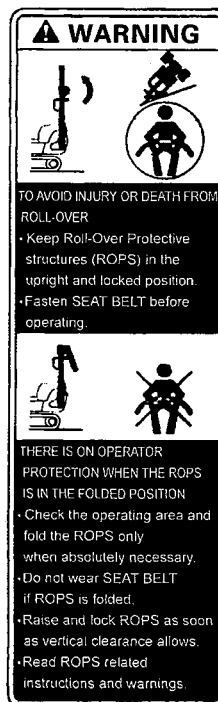

④ Part No. RD517-5795-1 [Both sides]

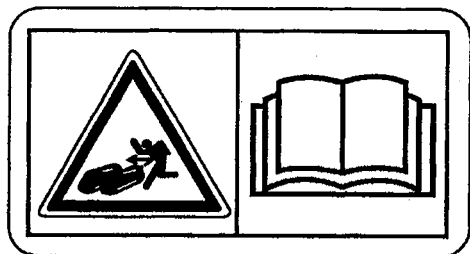

Labels : inside engine bonnet

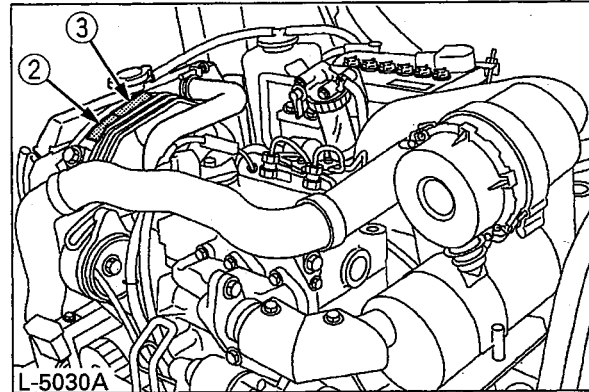
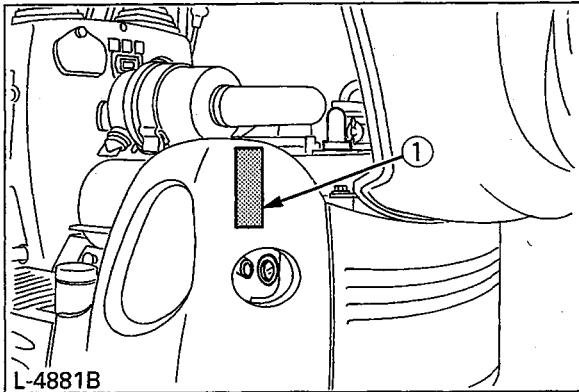

- ① Part No. TA040-4958-1
Do not touch hot parts
such as exhaust etc.

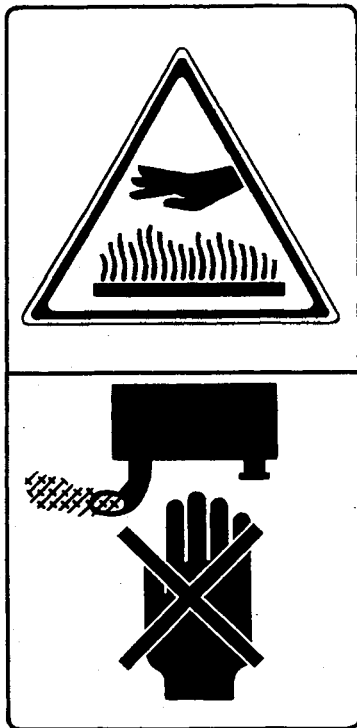

- ③ Part No. RA128-5776-1
Keep away from fan and
fan belt.



- ② Part No. RA028-5724-1
Radiator : Be aware of
the danger of burning.



7. CARE OF DANGER, WARNING AND CAUTION LABELS

- (1) Keep danger, warning and caution labels, clean and free from obstructing material.
- (2) Clean danger, warning and caution labels with soap and water, dry with a soft cloth.
- (3) Replace damaged or missing danger, warning and caution labels with new labels from your KUBOTA dealer.
- (4) If a component with danger, warning and caution label (s) affixed is replaced with new part, make sure new label (s) is (are) attached in the same location (s) as the replaced component.
- (5) Mount new danger, warning and caution labels by applying on a clean dry surface and pressing any bubbles to outside edge.

DEALER SERVICE

Your KUBOTA dealer is always ready to help so that your excavator offers the best performance. After having carefully read this manual, you will realize that much of the routine maintenance can be done by yourself. Your KUBOTA dealer is responsible for servicing and the delivery of spare parts. When ordering spare parts from your KUBOTA dealer, always mention the serial number of the excavator and the engine. Note these numbers right away in the supplied lines.

Model Serial No.
 Excavator _____
 Engine _____
 Dealer's name
 (To be filled in through the owner)

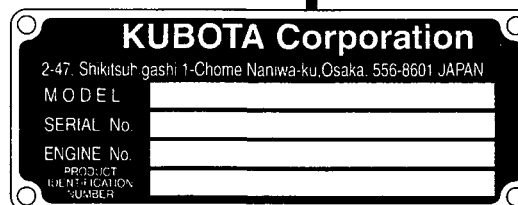
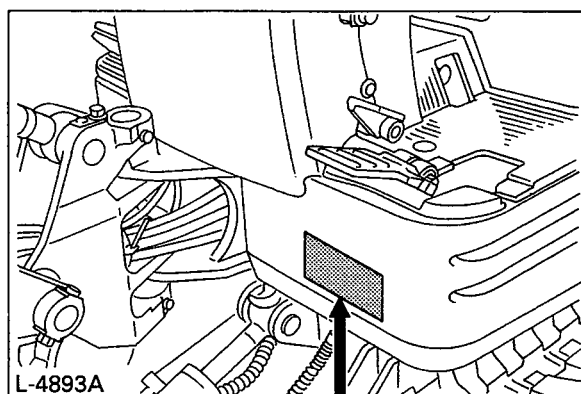

1BAAABSAP099A

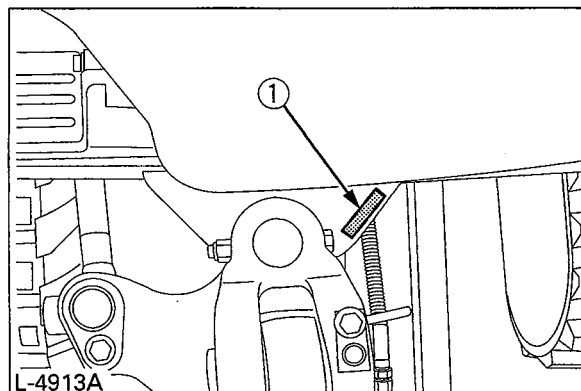

(1) Serial No.

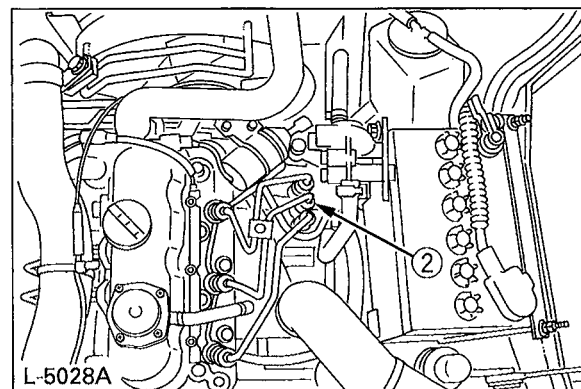

(2) Engine serial No.

TECHNICAL DATA

		KUBOTA EXCAVATOR	
Model name		K008-3	
Type		Rubber tracks	
Machine weight		kg	920
Standard bucket	Volume (CECE)	m ³	0.022
	Width	mm	350
Engine	Type	Water cooled 3 cylinder Diesel	
	Model name	*KUBOTA D722-EBH-3 **KUBOTA D722-E3-BH-3	
	Total displacement	m ³	719
	Engine power	HP (kW)	10.2 (7.4)
	Rated speed	rpm	2050
Performance	Swing speed	rpm	8.3
	Travel speed	km/h	2.0/4.0
	Ground pressure	kgf/cm ²	0.24
	Climbing angle	% (deg)	27 (15)
Dozer (width & height)		mm	700 x 200, 860 x 200
Boom swing angle	Left	rad (deg)	0.96 (55)
	Right	rad (deg)	1.05 (60)
Pressure connection for attachments	Displacement	L/min	21.0
	Max. pressure	kgf/cm ²	170
Fuel tank capacity		L	12

NOTE:

- Above dimensions are based on the machine with JPN bucket.
JPN = made in Japan
- * "Tier2" will be installed on the engines of the machines from the January 2005 production lot.
K008-3 #/ 013972-
- ** "Tier4" will be installed on the engines of the machines from the January 2008 production lot.
K008-3 #/ 018702-

DESCRIPTION OF MACHINE PARTS

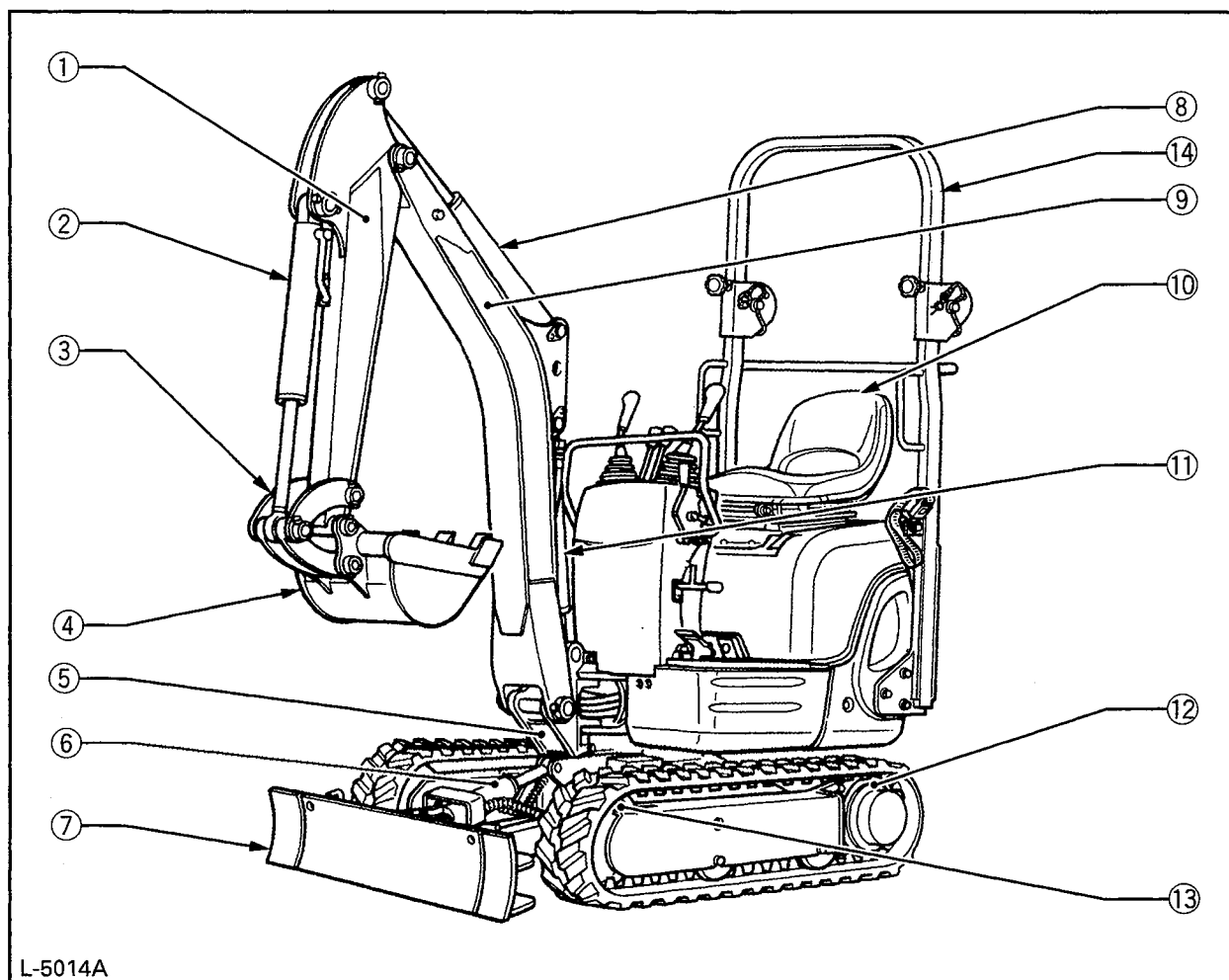

L-5014A

DEPICTED CONTENTS

- (1) Arm
- (2) Bucket cylinder
- (3) Bucket link
- (4) Bucket
- (5) Swing bracket
- (6) Dozer cylinder
- (7) Dozer
- (8) Arm cylinder
- (9) Boom
- (10) Operator's seat
- (11) Boom cylinder
- (12) Drive sprocket
- (13) Front idler
- (14) ROPS

INSTRUMENT PANEL AND CONTROL ELEMENTS

■ Instrument Panel, Switches

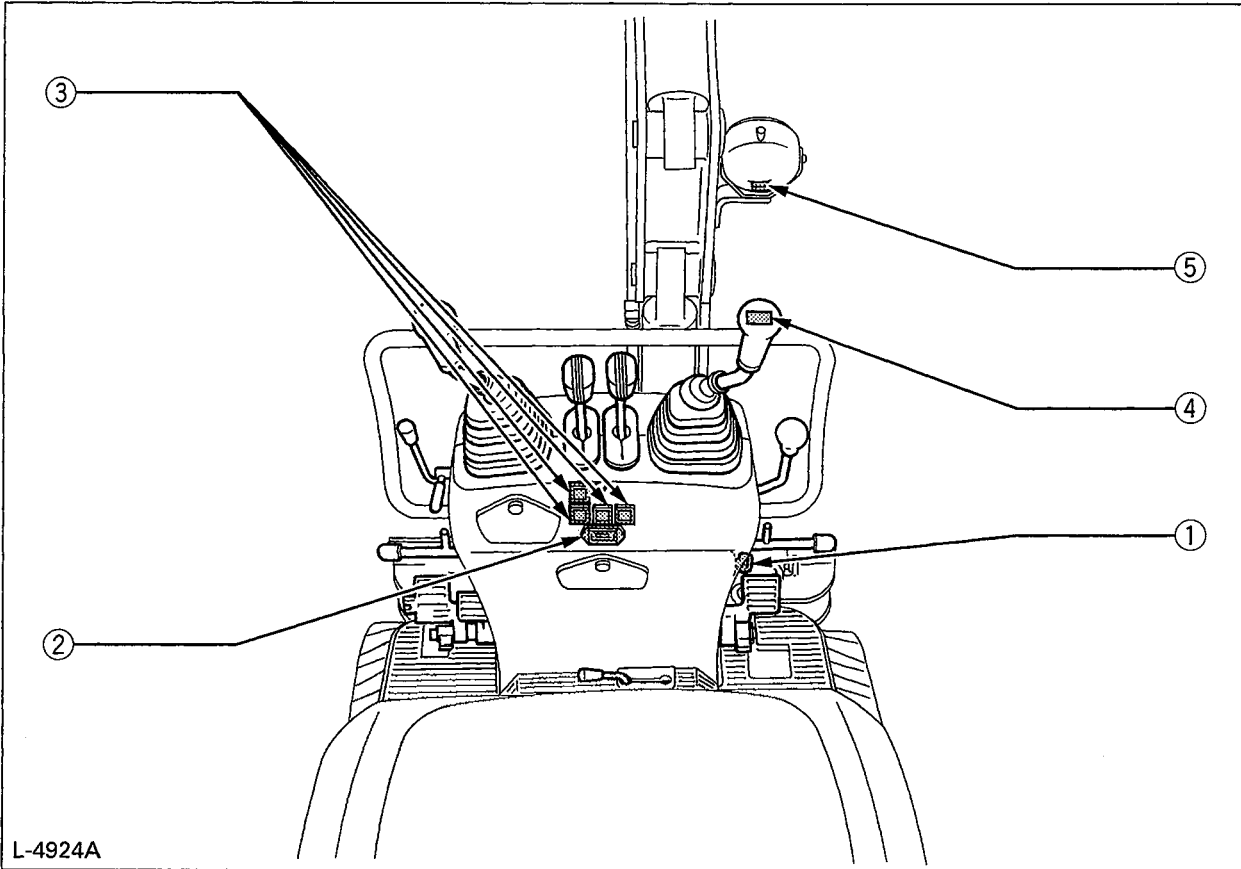

DEPICTED CONTENTS

- (1) *Starter switch*
- (2) *Hour meter*
- (3) *Alarm lamp*
- (4) *Horn switch*
- (5) *Working light switch*

Control Pedals and Levers

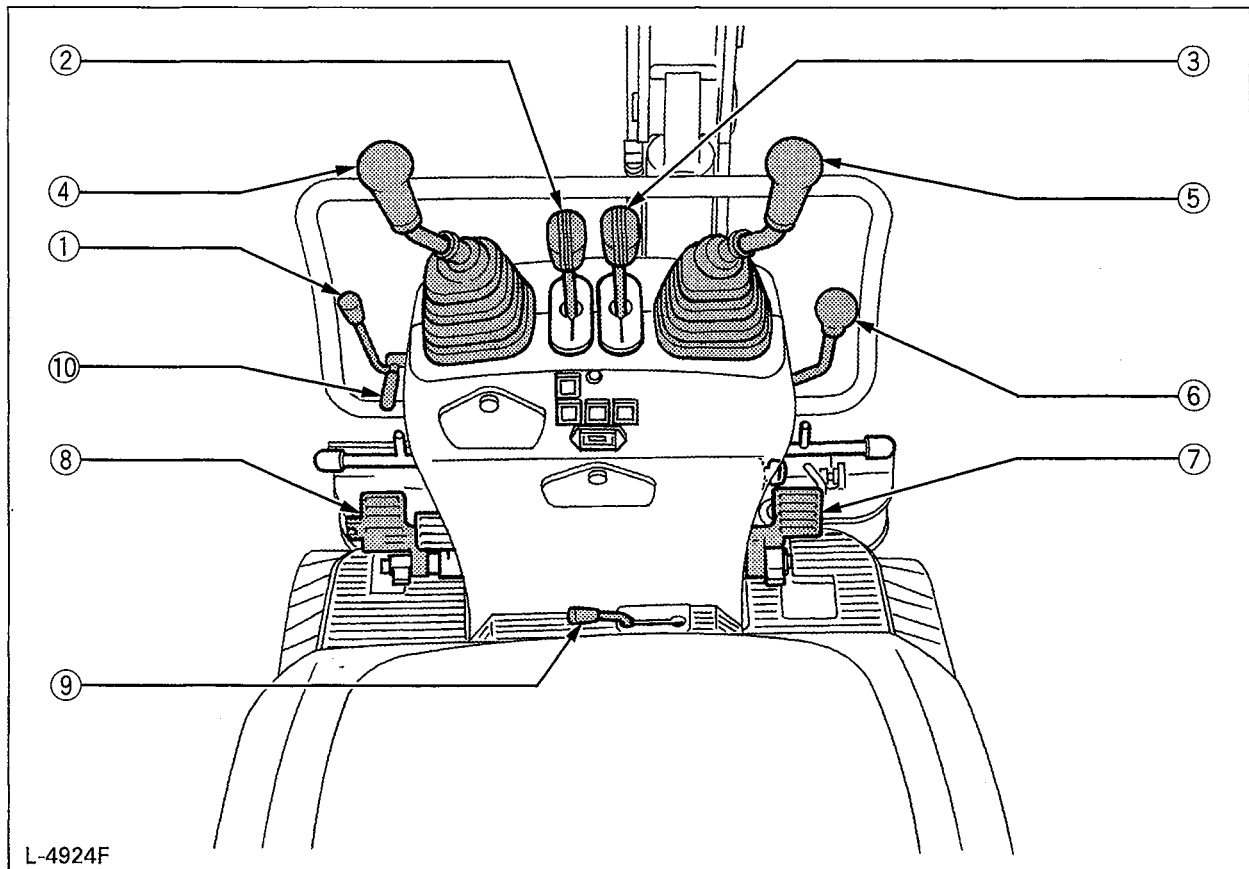

DEPICTED CONTENTS

- (1) Throttle lever
- (2) Drive lever (left)
- (3) Drive lever (right)
- (4) Control lever for front attachments (left)
- (5) Control lever for front attachments (right)
- (6) Control lever for dozer or track width
- (7) Swing pedal
- (8) Service port pedal
- (9) Track width change / dozer select lever
- (10) Lock lever

BEFORE START

HANDLING THE SAFETY DEVICES

Control lever lock



CAUTION

- When the excavator is not used or left unattended, be sure to place the bucket on the ground and lock the control levers. The front attachment may fall : it's dangerous. Also remove the key.

The attachment control lever lock is located on the left side alike.

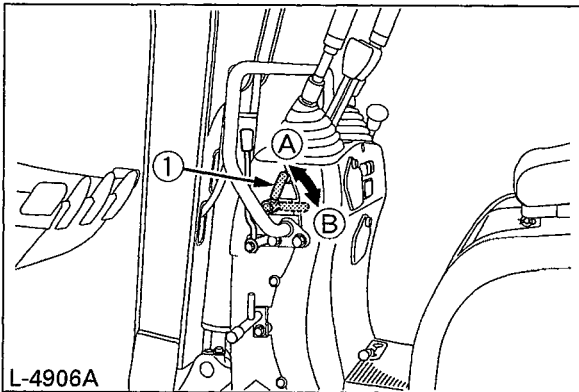

(1) Lock lever

(A) "Lock"

(B) "Unlock"

Swing lock pin

This pin is used to lock the swing frame. Set the lock pin to the "Lock" position and the swing frame gets locked to the track frame.

IMPORTANT:

- Before locking the lock pin, be sure to place the swing frame and the track frame parallel with each other.

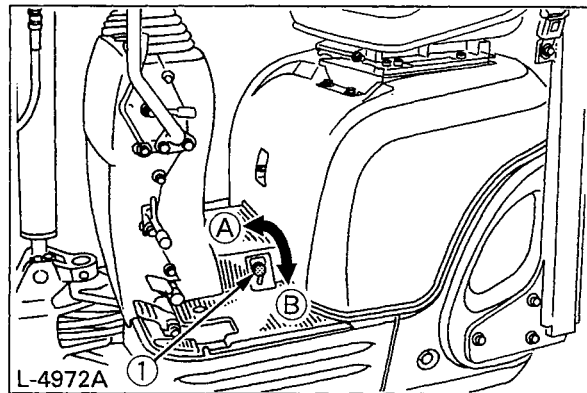

(1) Swing lock pin

(A) "Unlock"

(B) "Lock"

DAILY CHECKS

In order to avoid damage, it is important to check the condition of the excavator before starting.



CAUTION

To avoid personal injury:

- Do maintenance work on the excavator only on even ground with the engine off and the safety devices in the "Lock" position.

Checks

Walk around the excavator and check for visual damage and wear.

Check coolant level. (See regular checkpoints in "MAINTENANCE".)

Check fuel level.

Check engine oil level.

Check hydraulic fluid level.

Check air filter for clogging.

Check all alarm lamps and hour meter.

Check the light system.

Check the condition of the danger, warning and caution labels. (See "DANGER, WARNING AND CAUTION LABELS" in "SAFE OPERATION" .)

OPERATION OF THE ENGINE



CAUTION

To avoid personal injury:

- Read "SAFE OPERATION" at the beginning of this operator's manual.
- Obey the danger, warning and caution labels on the excavator.
- Exhaust gases are poisonous. Do not let the engine run in closed quarters without sufficient and adequate ventilation.
- Always start the engine from the operator's seat. Do not start the engine while standing next to the excavator. Before starting the engine, sound the horn to get the attention of persons standing nearby.

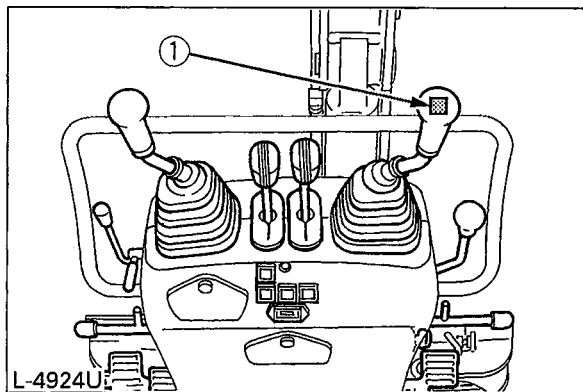

(1) Horn switch

IMPORTANT:

- Do not use start help spray or similar fluids.
- In order not to overload the battery and starter, avoid start-ups of more than 10 sec.
- When the engine does not start in 10 sec., please set the interval to 20 sec. or more, and restart.

STARTING THE ENGINE



CAUTION

To avoid personal injury:

- The operator should not depend solely on the alarm lamps, but should always conduct the routine checks (see "MAINTENANCE").

Start the engine in the following manner:

1. Make sure that the fuel cock is in the "Open" position.

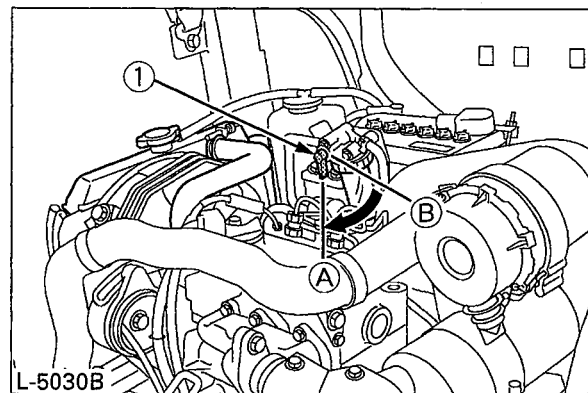

(1) Fuel cock

(A) "Open"

(B) "Closed"

2. Before starting the engine, make sure that all control levers are in the neutral positions.

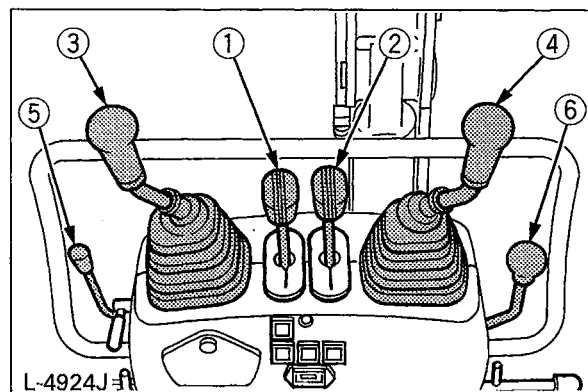

(1) Drive lever (left)

(2) Drive lever (right)

(3) Attachment control lever (left)

(4) Attachment control lever (right)

(5) Throttle lever

(6) Control lever for dozer or track width

3. Pull the throttle lever all the way back.
4. Insert the key into the starter switch and turn it to position "ON".

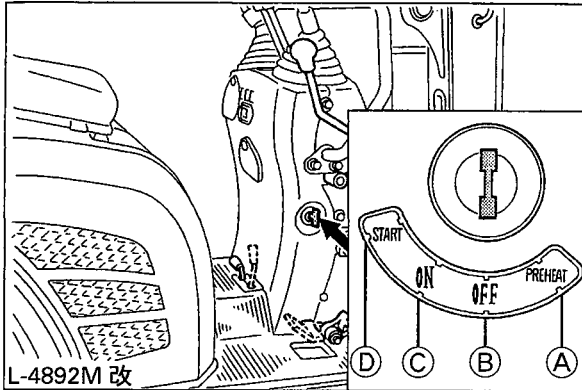

- (A) "PREHEAT"
 (B) "OFF"
 (C) "ON"
 (D) "START"

5. Turn the key to position "Preheat". (approx. 5 seconds)
6. Turn the key to position "Start" and release after the engine has started; it will automatically return to the position "ON".
7. Check if all alarm lamps have gone out. Should an alarm lamp still be lit up, stop the engine and check for the cause.

Malfunction Indicator (Quick Diagnosis)

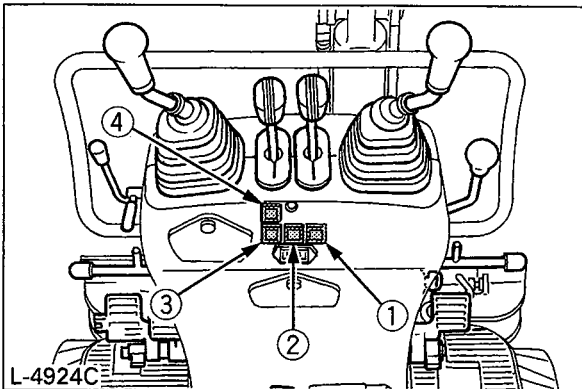

① Alarm Lamp "Battery Charge"

This lamp lights up when there is a malfunction in the electrical system. The lamp lights up when the key is in the "ON" position and goes out as soon as the engine starts.

② Alarm Lamp "Engine Oil Pressure"

This lamp lights up when there is an abnormality in the engine oil circulation. It lights up when the key is in the "ON" position and goes out as soon as the engine starts running. Should the lamp light up while the engine is running, check the engine oil level.

③ Alarm Lamp "Fuel Level too Low"

This lamp lights up when the fuel level in the fuel tank is lower than 2 L. The lamp lights up for three seconds to check the dead lamp when the key is in the "ON" position while the engine is stopped.

The lamp goes out when the key is in the "START" position while the dead lamp check is lit.

④ Alarm Lamp "Water temperature warning"

This lamp lights up if the cooling system gets in trouble while the engine is running. The lamp lights up for three seconds to check the dead lamp when the key is in the "ON" position while the engine is stopped.

The lamp goes out when the key is in the "START" position while the dead lamp check is lit. If the lamp stays on with the engine running, interrupt the operation and keep the engine at idling speed for about 5 minutes and then stop the engine. Now check the following points.

- (1) Check for cooling water shortage and leak.
- (2) Check the fan belt for looseness.
- (3) See if the radiator is covered with mud or dirt.

Hourmeter

The hourmeter shows the total operating hours of the excavator.

◆ Meter reading

The meter counts up 1 for one operating hour. The electric meter is still counting if the engine stops but the key is in the "ON" position.

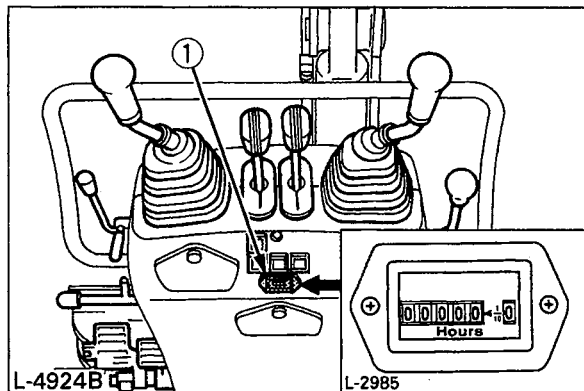

(1) Hourmeter

Checkpoints after Starting the Engine

After starting the engine, but before starting operation, check following points:

1. Put the throttle lever in the "LOW" position and let the engine idle for approx. 5 minutes. This allows the engine lubricant to warm up and penetrate every part of the engine.

NOTE:

- This idling is usually called "Warm-up".
- 2. Once the engine has warmed up, check:
 - the alarm lamp "Engine oil pressure" has gone out.
 - the alarm lamp "Battery charge" goes out when accelerating the engine.
 - the colour of the exhaust gas is normal and no abnormal noises or vibrations are heard or felt.
 - no fluid is leaking from pipes or hoses.

◆ Should any following conditions arise, stop the engine immediately.

- The engine revolution increases or decreases suddenly.
- Sudden abnormal noises.
- Exhaust gas is black.
- Alarm lamp for engine oil lights up during operation.

IMPORTANT:

- In these cases, the excavator must be checked and serviced according to the directions of the KUBOTA dealer.

STARTING THE ENGINE UNDER COLD CONDITIONS



CAUTION

To avoid personal injury:

- Make sure that the lock lever is in the lock position during warm up.

Start the engine in the following manner;

1. Pull the throttle lever completely all the way back.
2. Turn the key to the "PREHEAT" position. (approx. 10 sec.)
3. Turn the key to the "START" position; the engine will start.
4. Release the key after the engine has started; it will automatically return to the "ON" position.

IMPORTANT:

- Let the engine warm up after start-up.
- Let the engine warm up after start-up for approx. 10 minutes under no load conditions. If the hydraulic fluid temperature is too low, the operation will be affected.

Do not operate the excavator under full load before the engine is warmed up enough.

STOPPING THE ENGINE



WARNING

To avoid personal injury or death:

- Do not keep the bucket or dozer in the lifted position, as a person could accidentally touch the levers and cause serious accidents.
- Lower all work attachments on to the ground, otherwise accidents could occur.

Let the engine idle for approx. 5 minutes to let it cool down.

1. Put the throttle lever in idle position.
2. Lower the work attachments carefully on the ground by activating the levers.
3. To stop the engine, turn the key to the "OFF" position and remove the key.

Engine Stop Lever



CAUTION

To avoid personal injury:

- In the case of an emergency, or should the engine in idle position and key in the off position, still run, do like as below.

Open the engine bonnet and push the stop lever back and hold until the engine stops.

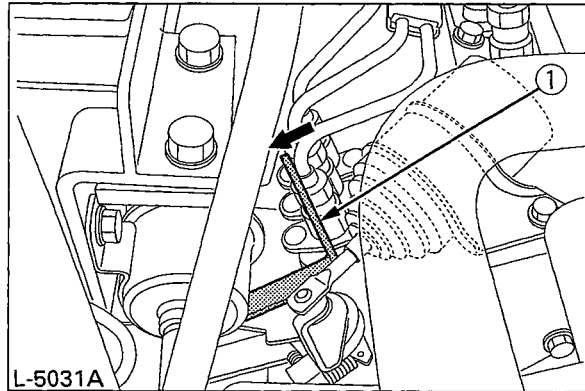

(1) Engine stop lever

IMPORTANT:

- If the throttle lever is not in the idle position, the engine will continue to turn even if the key is in the "OFF" position. Make sure that the throttle lever is in the idle position before turning the key.
- If the engine does not stop with the key, contact your KUBOTA dealer.

STARTING WITH AN AUXILIARY BATTERY



CAUTION

To avoid personal injury:

- Battery gases can explode. Do not smoke and keep sparks and flames away .
- Do not start the engine with an auxiliary battery if excavator battery is frozen.
- Do not connect the black minus bridge cable to the minus terminal of the excavator battery.

■ Observe Following Guidelines when Starting with an Auxiliary Battery.

1. Bring the second machine with the same battery voltage as near as possible to the excavator.
THE MACHINES MUST NOT COME IN CONTACT WITH EACH OTHER.
2. Put the levers and pedals of both vehicles in the neutral position and the lock lever in the "Lock" position.
3. Wear eye protection and rubber gloves.
4. Remove the battery caps from both batteries. (If present)
5. Cover the battery opening with a cloth. Make sure that the cloth does not touch the battery terminals.
6. Connect the terminal of the red jump lead with the plus terminal of the empty battery and connect the other end of the cable to the plus terminal of the auxiliary battery.
7. Connect the black cable to the minus terminal of the auxiliary battery.
8. Connect the other end of the black cable (coming from the auxiliary battery) with the excavator frame as far away as possible from the empty battery.
9. Start the engine of the second machine and let it run for a while. Start the excavator with the empty battery.
10. Disconnect the jump leads in the opposite sequence (Steps 8, 7, 6).
11. Remove the cloth and replace the battery caps.

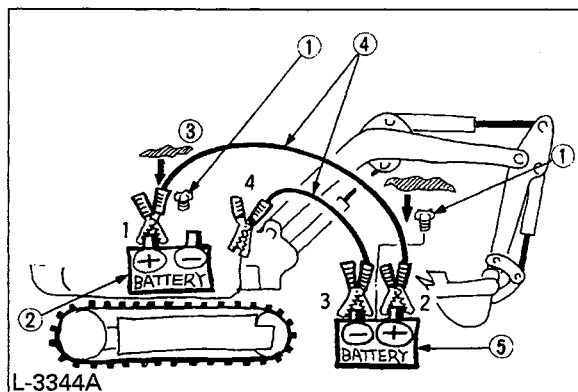

- (1) Remove battery caps (if present)
- (2) Empty battery
- (3) Put a cloth over the battery openings
- (4) Jump leads
- (5) Auxiliary battery

IMPORTANT:

- This excavator has a negative earthed 12 Volt starting system.
- Only use the same voltage when using an auxiliary battery.
- Using a higher voltage will cause serious damage to the electrical system. When using an auxiliary battery, only the compatible (same) voltage is permissible.

■ Precautions in case of overheat



CAUTION

To avoid personal injury:

- Do not open the radiator cap during and just after operation. Hot water may gush out and get you burned. Wait long enough until the radiator cools down.

If by any change cooling water gets heated up to the boiling point or over (overheated), the whistle at the reserve tank drain hose end blows. In such case, take the following steps.

1. Stop operation in a safe condition. (Disconnect the engine's load.)
2. Do not stop the engine suddenly. Keep the engine idling under no load for about 5 minutes and turn it off.
3. Keep yourself enough away from the machine for another 10 minutes or while steam is given off.
4. Make sure there is no hazard of getting burned. Pinpoint and remove the cause of overheat, referring to "TROUBLESHOOTING". Then get the engine restarted.

EXCAVATOR OPERATION

CONTROL OBSERVATIONS DURING OPERATION

■ Stop the Engine immediately if:

- Sudden increase or decrease in engine revolution occurs.
- Sudden abnormal noises occur.
- Exhaust gases turn suddenly very dark.

Make following control observations during operation to be sure that everything functions normally.

■ Alarm Lamps

Should an alarm lamp light up during operation, stop the engine immediately and as described below, check for the cause. Do not use the excavator when an alarm lamp is lit up. Explanation of alarm lamp is described as "Malfunction Indicator (Quick Diagnosis)" under "STARTING THE ENGINE" in "OPERATION OF THE ENGINE".

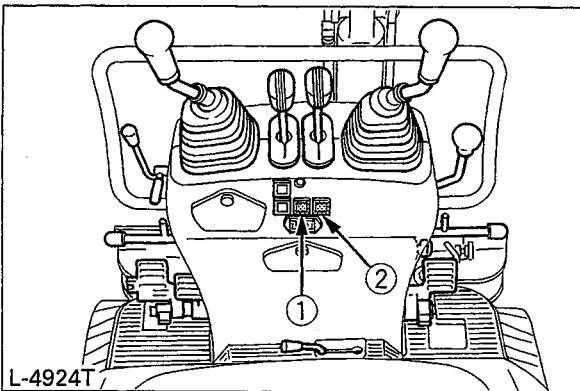

① Engine Oil Pressure

When the engine oil pressure sinks below the prescribed level, the alarm lamp will light up. Should this occur during operation and not go out even if the engine revolution is increased by 1000 rpm, check the engine oil level. (see "Check Engine Oil Level" under "DAILY CHECKS" in "MAINTENANCE").

② Battery Charge

If the battery is not charged by the generator, the alarm lamp will light up. Should this occur during operation, check the electrical system or contact your KUBOTA dealer. (see "TROUBLESHOOTING")

RUNNING-IN OF THE NEW EXCAVATOR

The operation and care of the new excavator influences its life span. Your new excavator has been carefully checked and tested before leaving the factory. In spite of this, all movable components must run-in during the first 50 work hours. Do not work with full revolution and full loads during this period. It is most important to run-in your excavator properly in order to achieve its full performance and longevity. During the running-in, the following points should be adhered to in all cases.

■ Do not Work with Full Revolutions or Full Loads during the First 50 Working Hours.

- Let the engine warm up sufficiently in the cold season.
- Do not let the engine rev-up more than necessary.

■ Oil Change in the Run-in Stage.

The lubrication oil plays a specially important role during the run-in phase of the excavator. The numerous movable parts are not yet run-in, so that many fine metal particles can develop and cause damage or shorten the lifetime of many components. Pay attention to the oil-change intervals and execute them sooner rather than later as necessary. See the subject "Care and Maintenance" for more details on the oil-change intervals.

STARTING



CAUTION

To avoid personal injury:

- No persons, other than those familiar with the excavator, are allowed to use the excavator.
- Do not allow any person other than the operator to ride on the excavator.

■ Seat Belt and Adjusting the Operator's Seat



WARNING

To avoid personal injury or death:

- Always use the seat belt if a ROPS protection construction is built in. Adjust the seat to the optimal position and buckle up.

1. Adjusting the Operator's Seat



CAUTION

To avoid personal injury:

- Before adjusting the operator's seat, make sure that no one puts hands on the engine bonnet behind the seat.
- After having adjusted the seat, make sure that the seat adjuster has clicked into position.

To and fro: While holding up the to-and-fro adjustment lever, reposition the seat to and fro.

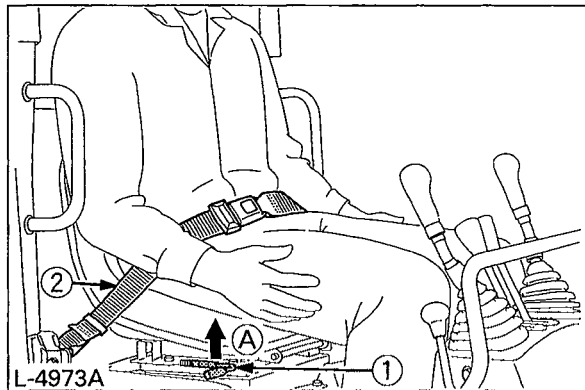

(1) To-and-fro adjustment lever

(A) "Hold up"

(2) Seat belt

2. Bring the lock lever into the "Unlock" position.



CAUTION

To avoid personal injury:

- Check safety aspects all around the excavator.

Please bring the lock lever into the "Unlock" position, and raise the lower side of the bucket from the ground by 20 to 40 cm.

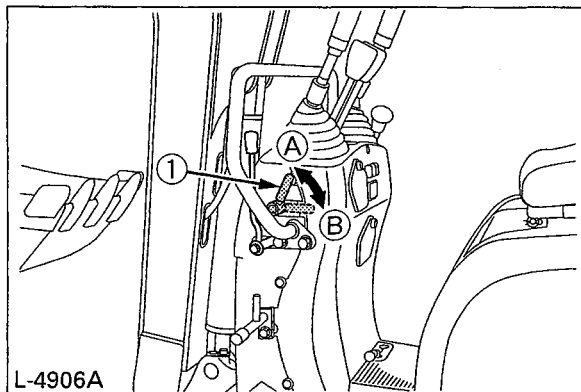

(1) Lock levers

(A) "Lock"

(B) "Unlock"

Working Light Switch

If the key is in the "ON" position, the lights will be switched on by tipping the switch.

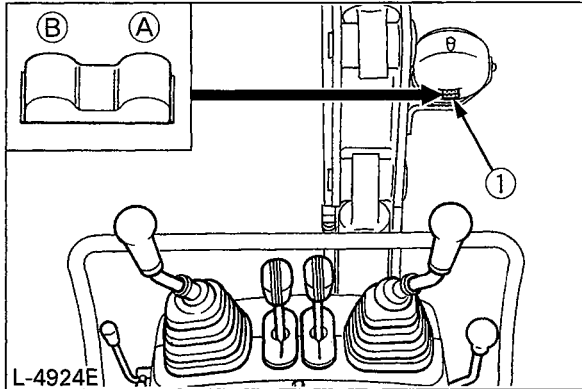

(1) Working light switch (A) "ON"
(B) "OFF"

Night operation



CAUTION

To avoid personal injury:

- Visibility is reduced in darkness, so that the working light alone is not enough. Prepare additional lighting, observe safety rules as well as special regulations for night work.

CONTROLS FOR ATTACHMENTS

The levers move the boom, arm and bucket as well as the swing frame. The lever positions and functions are as follows:

[NOT TWO PATTERN SELECTION TYPE]



CAUTION

To avoid personal injury:

- Study and familiarize control lever functions by operating slowly.
- Be sure to check the operating pattern in the label on the front bonnet before operating the excavator.

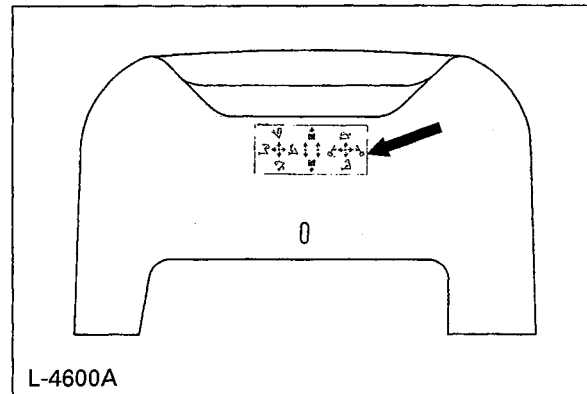

L-4600A

[TWO PATTERN SELECTION TYPE]



WARNING

To avoid personal injury or death:

- The control lever pattern on this machine is changeable. Before operation, check the current pattern. Otherwise the machine may get in trouble or you may get injured.
- Before changing the control lever pattern, be sure to stop the engine.
- Before operation, be sure to look around for safety. Move the levers slowly.
- Make sure the control lever pattern has been changed as specified.

◆ **Pattern Change**
Switching from [Pattern A] to [Pattern B]

1. Stop the engine and place the front attachment on the ground. Release pressure out of the cylinders.
2. Turn the knob on the control box to open the cover.

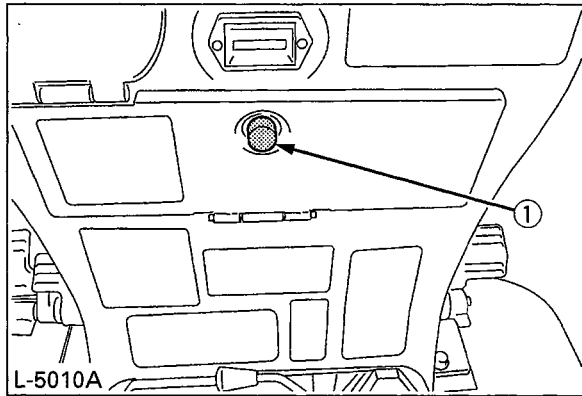

(1) Knob

3. Remove the bolts (1) and (2).

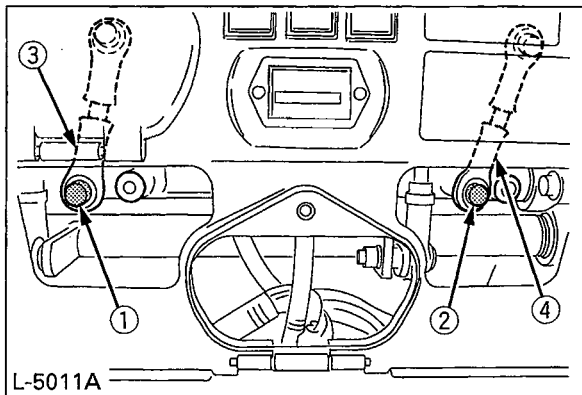

(1) Bolt1
 (2) Bolt2

(3) Joint(C)
 (4) Joint(D)

4. Shift the joints (C) and (D) to the right, and apply and tighten up the bolts (1) and (2).

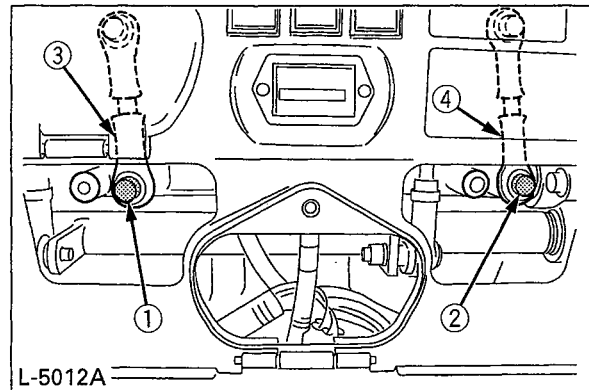

(1) Bolt1
 (2) Bolt2

(3) Joint(C)
 (4) Joint(D)



CAUTION

To avoid personal injury:

- The bolts (1) and (2) are of special type. Do not use general bolts, because otherwise the machine may malfunction and get damaged.

Switching from [Pattern B] to [Pattern A]

1. Stop the engine and place the front attachment on the ground. Release pressure out of the cylinders.
2. Turn the knob on the control box to open the cover.

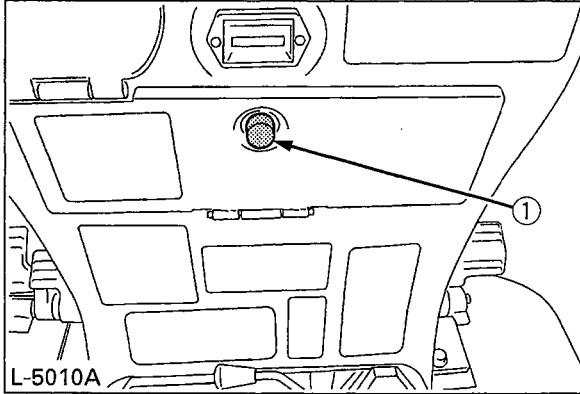

(1) Knob

3. Remove the bolts (1) and (2).

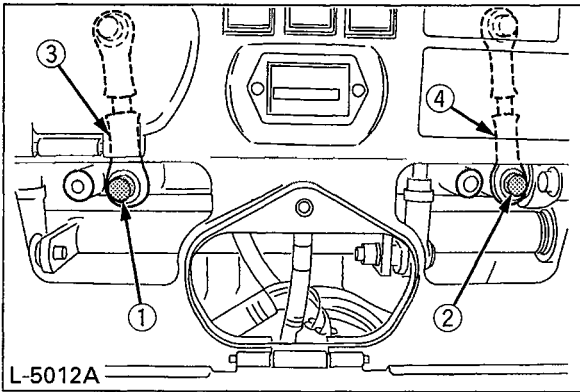

(1) Bolt1
(2) Bolt2

(3) Joint(C)
(4) Joint(D)

4. Shift the joints (C) and (D) to the left, and apply and tighten up the bolts (1) and (2).

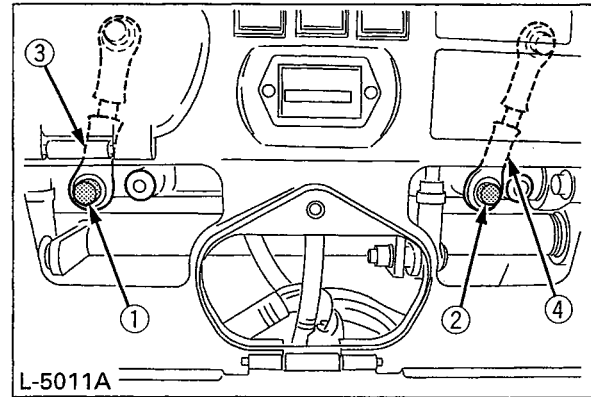

(1) Bolt1
(2) Bolt2

(3) Joint(C)
(4) Joint(D)



CAUTION

To avoid personal injury:

- The bolts (1) and (2) are of special type. Do not use general bolts, because otherwise the machine may malfunction and get damaged.

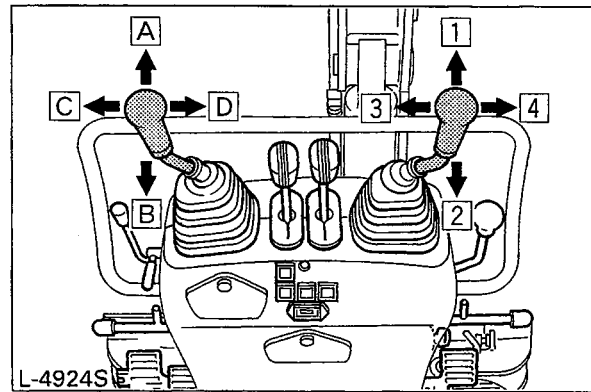

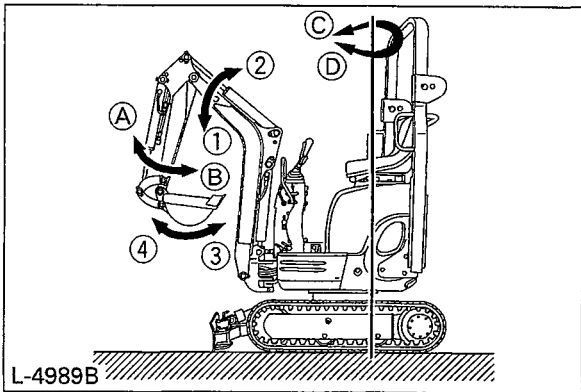
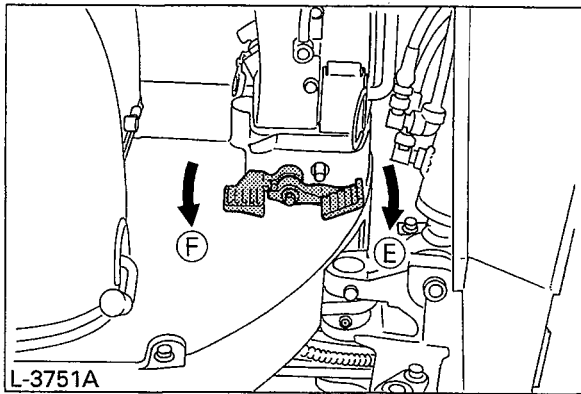

Lever Position		Movement	
		Pattern A(JD)	Pattern B (ISO)
Left Front Attachment Control Lever	A	Boom lower	Arm out
	B	Boom raise	Arm in
	*C	Swivel to left	Swivel to left
	*D	Swivel to right	Swivel to right
Right Front Attachment Control Lever	1	Arm out	Boom lower
	2	Arm in	Boom raise
	3	Bucket dig	Bucket dig
	4	Bucket dump	Bucket dump

***NOTE:**

- See "SWIVEL MOVEMENT AND SWING MOVEMENT".

OPERATION OF THE BOOM

To raise the boom, pull the attachment control lever back.

The boom is equipped with a cushion cylinder which prevents excavated material in the bucket from fall-in out. By low hydraulic oil temperature, (e.g. right after starting the engine) the cushioning function will only be effected after a certain delay (approx. 3 to 5 seconds). This condition results from the viscosity of the hydraulic oil and is no sign of a malfunction.

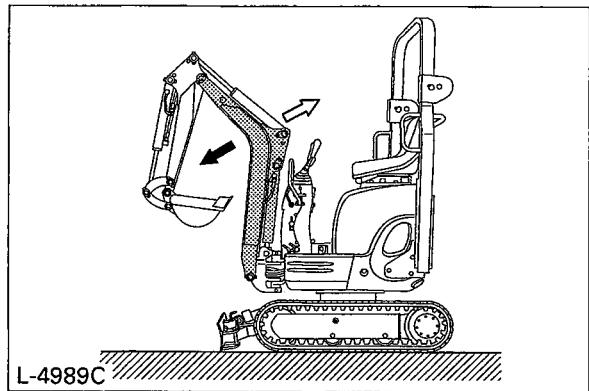
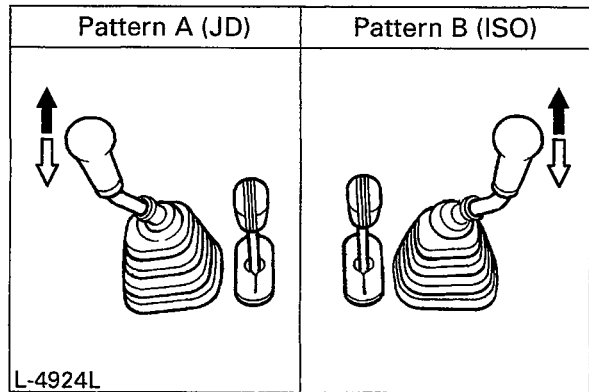

IMPORTANT:

- When lowering the boom, make sure that it does not hit the dozer and that the bucket teeth do not touch the dozer.

OPERATION OF THE ARM

Pull back the left attachment control lever and the arm will be pulled in. To move the arm out, push the control lever towards the front.

IMPORTANT:

- When pulling in the arm, the movement may stop for a short moment when the arm is in its vertical position. This is caused by the fact that at this position the maximum load for the arm and bucket is reached, and the hydraulic pressure in the cylinder is not high enough. This is a characteristic of the hydraulic system and is not a sign of a malfunction.

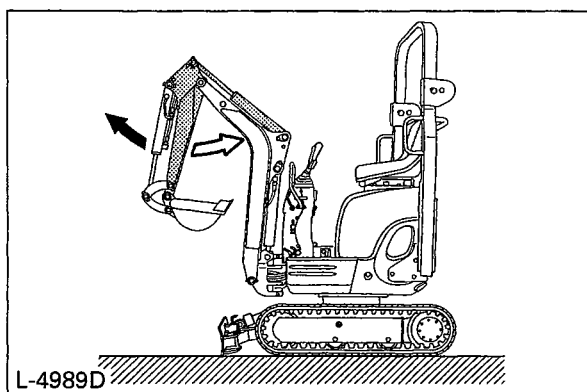
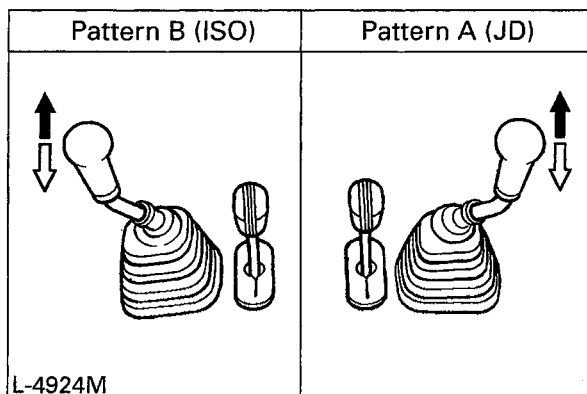

OPERATION OF BUCKET

To dig with the bucket, move the right attachment control lever from the neutral position towards the left. Moving the control lever towards the right pushes the bucket outwards and dumps its contents.

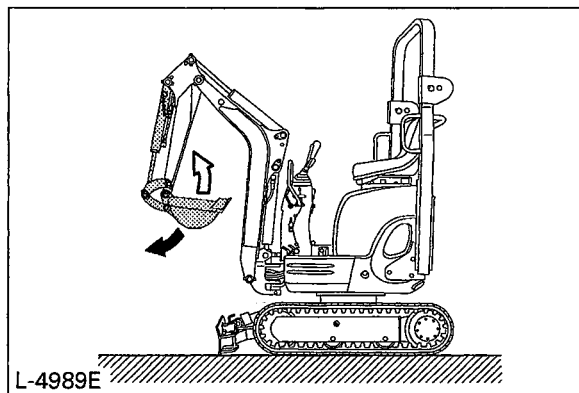
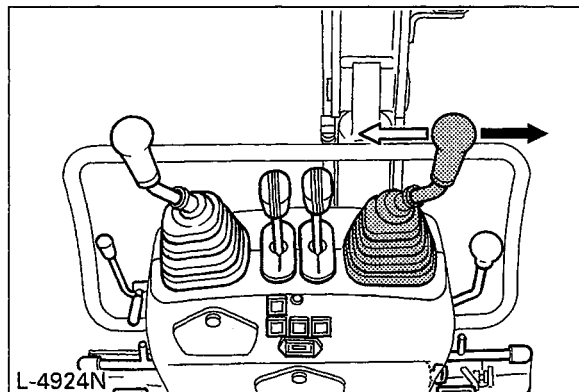

SWIVEL (UNIT SWING) OPERATION



CAUTION

To avoid personal injury:

- When working in groups, always let the others know what you are going to do before you do it.
- Keep away from the working area.

IMPORTANT:

- Do not operate the left attachment control lever abruptly from the right to the left (or vice versa). Because of the law of inertia, this causes an impact load on the swing gear and the swing motor. Additionally, the lifetime of the excavator will be shortened.
 - Unlock the swing lock pin before carrying out swivel operations.
1. Tilt the control lever to the left and the upper structure will turn to the left.
 2. Tilt the control lever to the right and the upper structure will turn to the right.

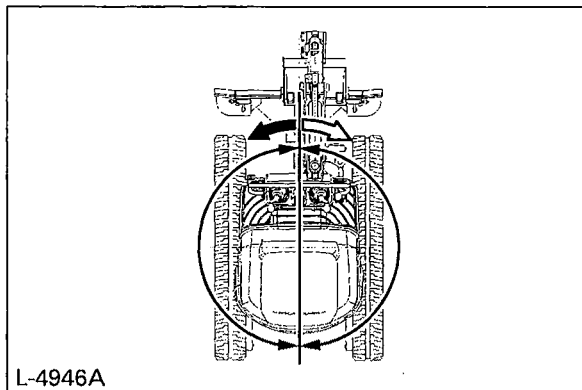
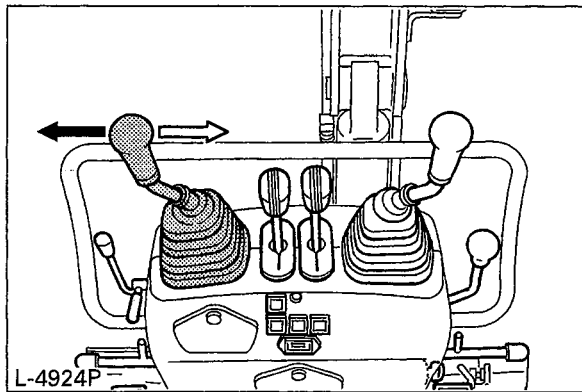

BOOM SWING OPERATION

1. Step on the front of the pedal to swing the boom to the left.
2. Step on the rear of the pedal to swing the boom to the right.

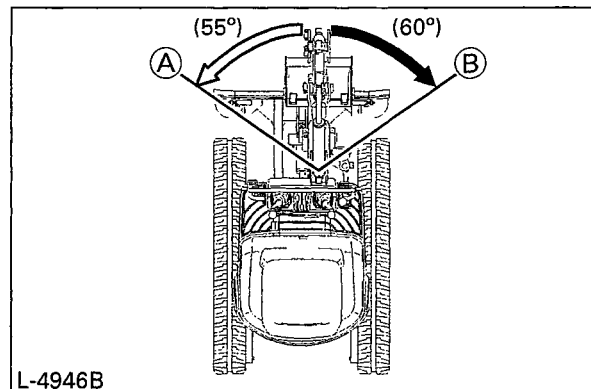
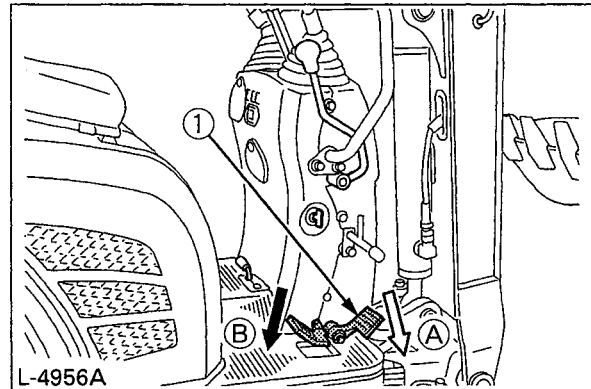

(1) Boom swing pedal

(A) Swing to left
(B) Swing to right

BOOM SWING PEDAL



WARNING

To avoid personal injury or death:

- Always keep your toes within the edge of foot step; otherwise there is a possibility that your toes will be caught between swing frame and boom or boom cylinder.



CAUTION

To avoid personal injury:

- When boom swing operation is not in use, fold the boom swing pedal forward to fix the pedal from unexpected moves.

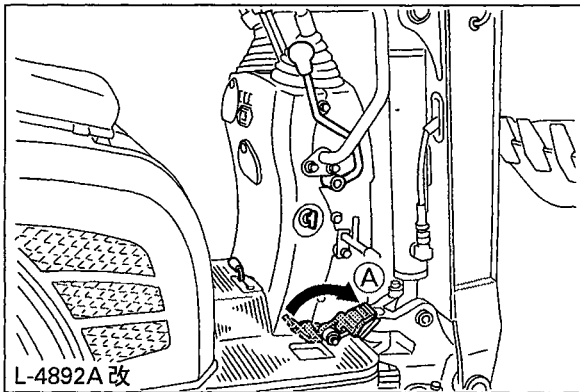

(A) "Fix"

OPERATION OF TRACK WIDTH CHANGE AND DOZER



CAUTION

To avoid personal injury:

- Do not operate in narrow track width 700mm, there is a risk of the excavator tipping over, always operate in standard track width 860mm, except when passing through narrow spaces on a even ground.
 - For changing the track width or using the dozer, set the track width change/dozer select lever fully.
- If not, the excavator may unintentionally move.

Operation of the Track Width

1. Set the track width change/dozer select lever to the "Track width change" position (B).

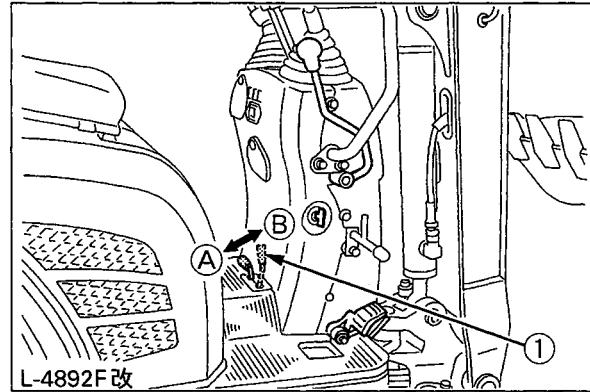

(1) Track width change / dozer select lever (A) "Dozer" (B) "Track width change"

2. Push the control lever forward.
... The track width reduces from 860mm to 700mm.
Pull the control lever backward.
... The track width increases from 700mm to 860mm.

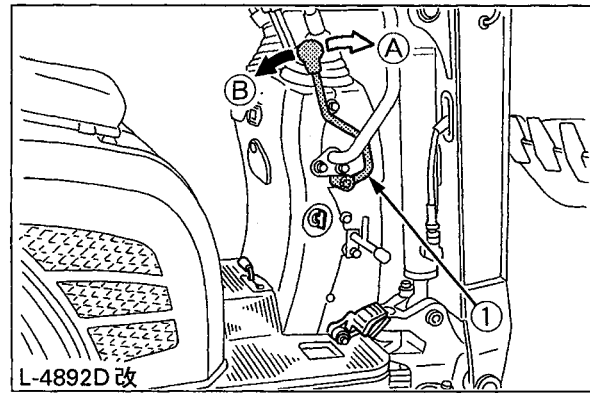

(1) Control lever (A) "Reduce" (B) "Increase"

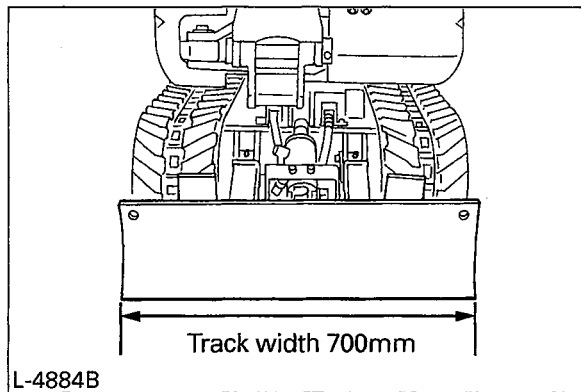
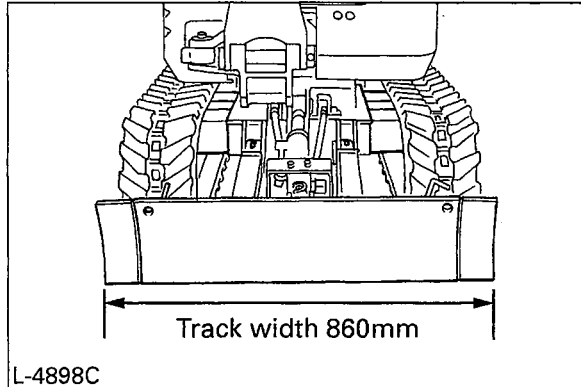

3. After track width change, be sure to set the track width change/dozer select lever to the "Dozer" position (A).

■ Operation of the Dozer Width

For changing from standard width to narrow width:

1. Pull out the fixing pin ② and remove the extension dozer ①.
2. Set the extension dozer ①, insert fixing pin ② as illustration.
3. It is the same operations for opposite side (left or right), and also for changing from narrow width to standard width.

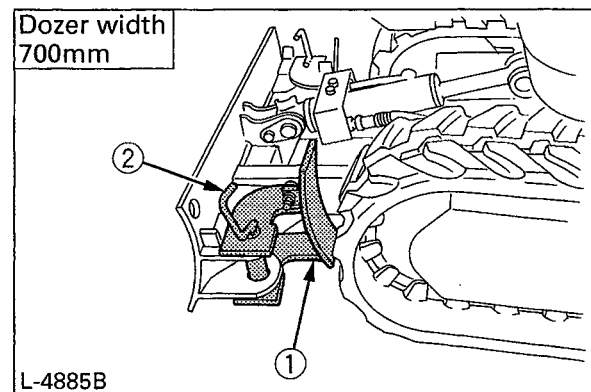
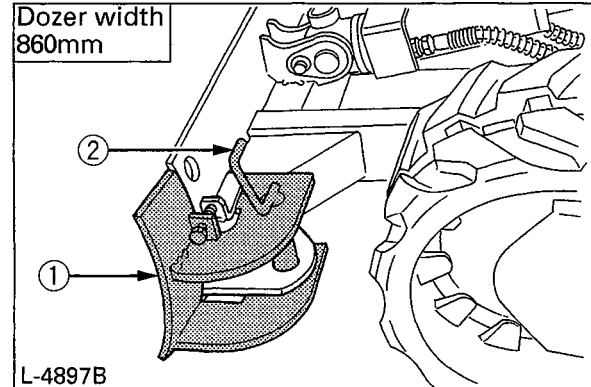

- (1) Extension dozer
(2) Fixing pin

■ Operation of the Dozer

NOTE:

- While operating the dozer, the track width change / dozer select lever must be set position (A).

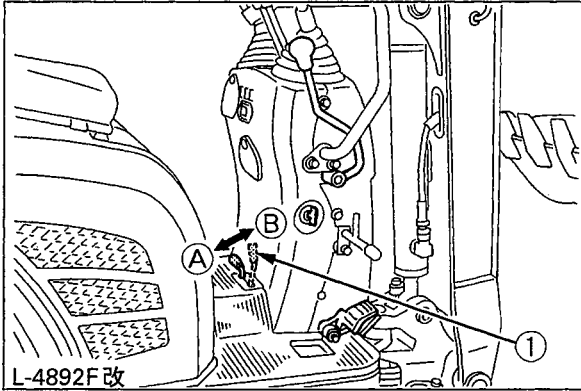

(1) Track width change / dozer select lever (A) "Dozer" (B) "Track width change"

1. To raise the dozer, pull back the control lever. Pushing the control lever forwards, lowers the dozer.

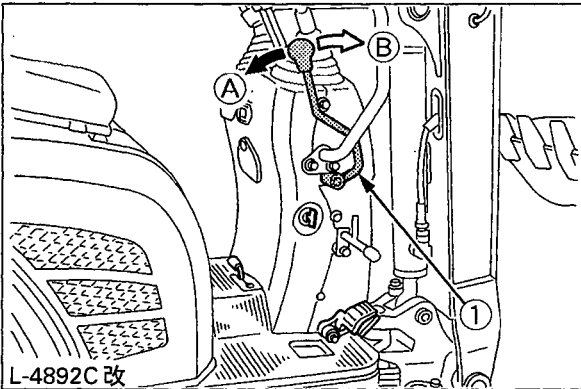

L-4892C 改

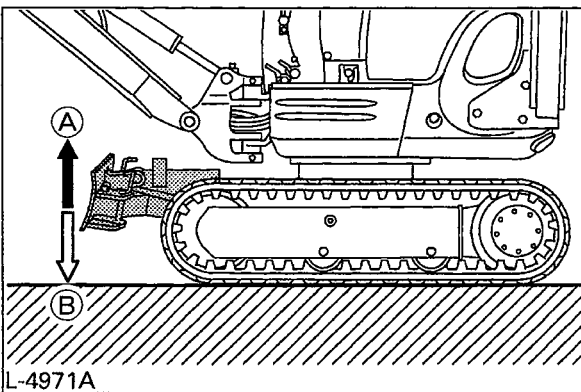

L-4971A

(1) Control lever (A) "Raise" (B) "Lower"

2. While undertaking earth moving work, control both drive levers with the left hand and the control lever with the right hand.

DRIVING



WARNING

- To avoid personal injury or death:
- Before starting the engine, make sure that no further persons are in the excavator surroundings.
 - Before operating the excavator, check the crawler direction. (Idler and dozer to the front of the excavator).

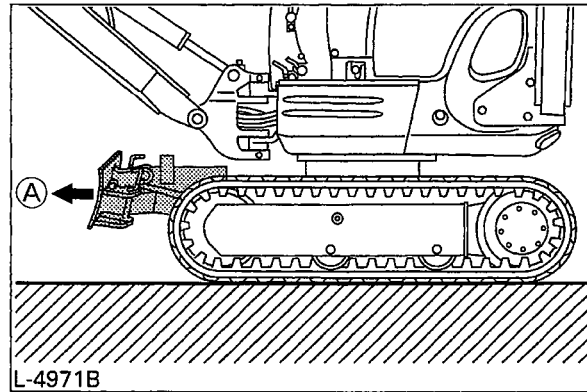

L-4971B

(A) "Front"

- Avoid travelling across a slope or working sideways on a slope.

1. To lock the swing frame with the track frame, engage the swing lock pin.
2. Adjust the engine speed from idling to an intermediate speed.
3. Raise the dozer and hold the bucket about 20 to 40 cm off the ground.

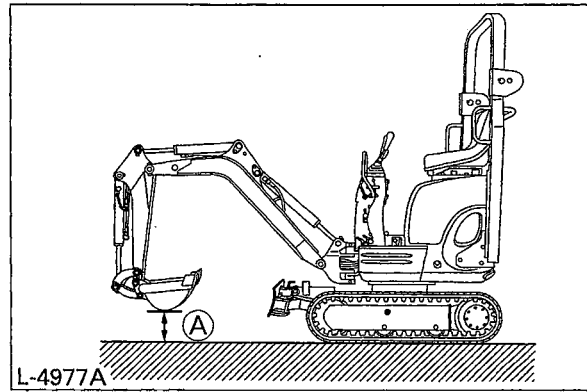

L-4977A

(A) 20 to 40 cm

Drive Levers (Right, Left)



WARNING

To avoid personal injury or death:

- If the swing frame has been turned 180°, i.e. the dozer is, seen by the operator, "behind", then the travel direction is opposite to the drive direction of the levers (when activating the drive lever forwards, the excavator, seen by the operator, will move backwards).

5. Pushing the drive lever forward, moves the excavator forward, and vice-versa. The front of the excavator is the direction where the dozer is present.

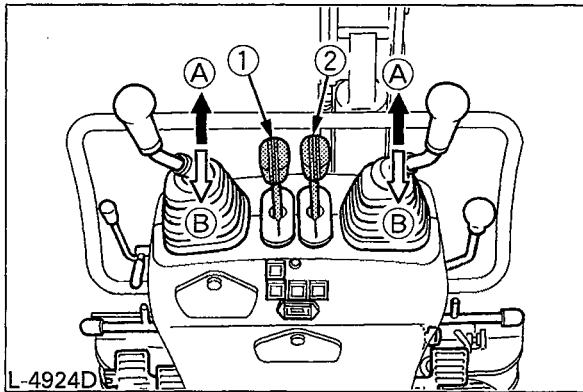

(1) Drive lever (left)
(2) Drive lever (right)

(A) "Forward"
(B) "Backward"

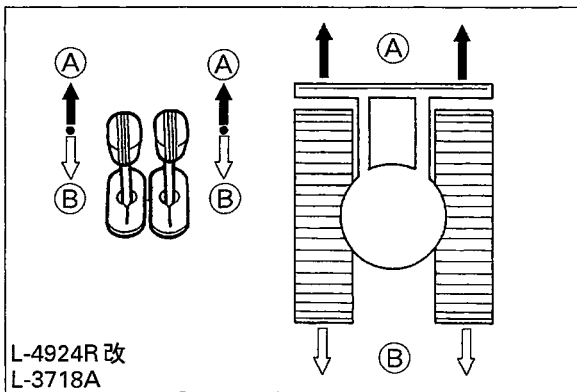

(A) "Forward"
(B) "Backward"

IMPORTANT:

- If the crawler is clogged with sand or gravel while working on soft ground, lift up one crawler with the help of the boom, arm and bucket and let the crawler rotate to shake off the sand and gravel.

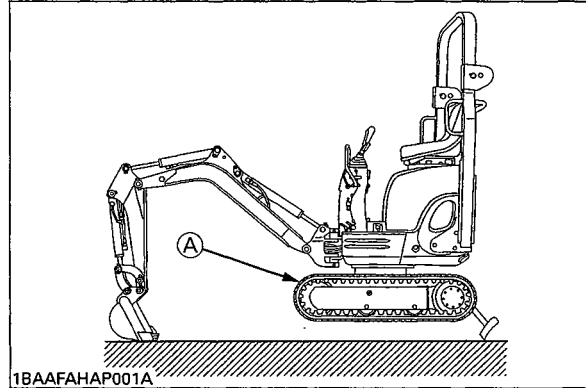

(A) "Rotate to shake off sand and gravel"

TURNS



CAUTION

To avoid personal injury:

- Do not change direction on steep slopes, or the excavator could tip over.
- Before changing direction, beware of persons in the working area.

Pivot Turn

NOTE:

- Movement as illustrated shows turning motion with the dozer positioned facing the front.

When the dozer is facing the back, the turning direction is reversed.

(For example, push the left (right) drive lever forward; right (left) crawler, seen by the operator, will move backward from the operator.)

◆ **Change of Direction while Stationary**

1. Push the left (right) drive lever forward; the excavator will turn to the right (left).

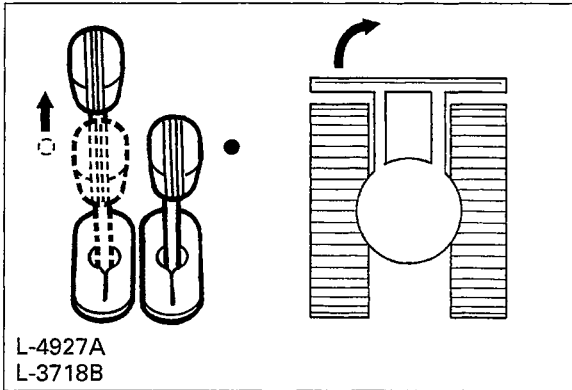

2. Pull the left (right) drive lever backward; the excavator will turn to the left (right).

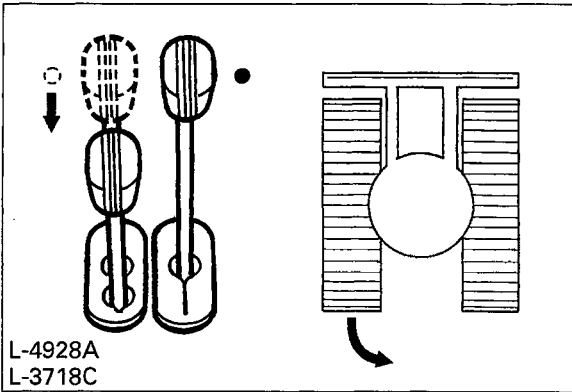

◆ **Change of Direction while Travelling**

1. While travelling forwards, bring the left (right) drive lever in the neutral position; the excavator will turn to the left (right).

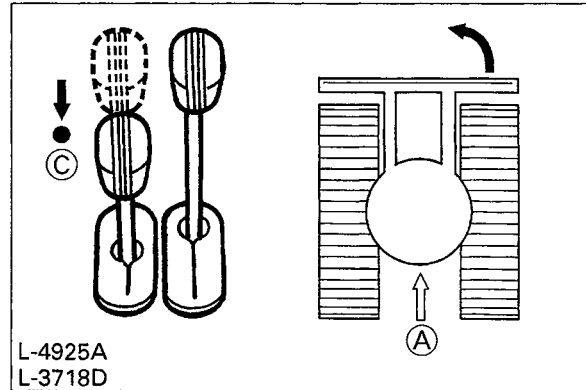

(A) "Travelling forward"
(C) "Neutral position"

2. While travelling backwards, bring the left (right) drive lever in the neutral position; the excavator will turn to the right (left).

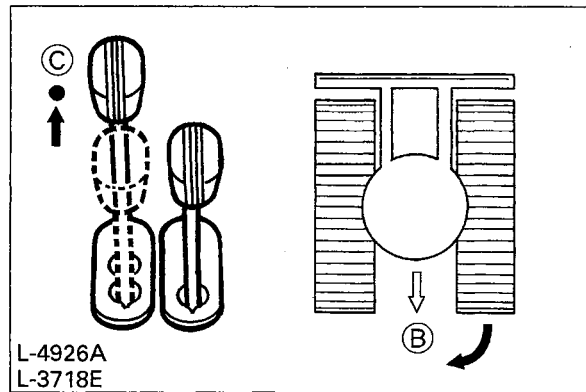

(B) "Travelling backward"
(C) "Neutral position"

Spin Turn

When both drive levers are activated in the opposite directions, both crawlers will rotate with the same speed but in opposite directions. Centre of rotation is the centre of the excavator.

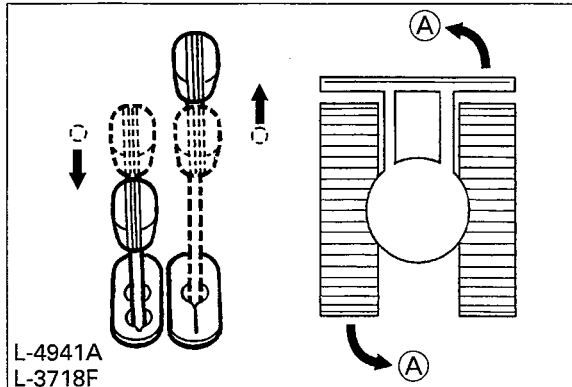

(A) "Left spin turn"

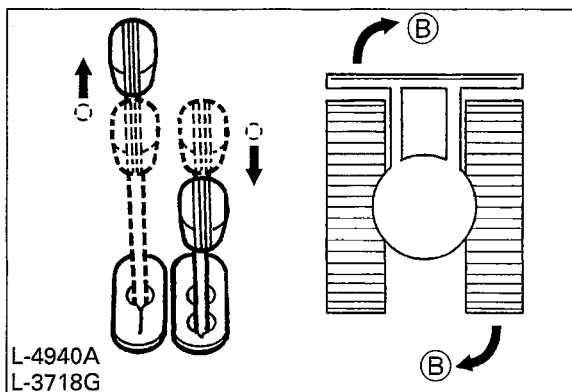

(B) "Right spin turn"

UP AND DOWNHILL TRAVELLING



CAUTION

To avoid personal injury:

- Before travelling up and downhill, be sure to be in standard track width 860mm.
- When travelling up or down a slope for long periods of time, be sure to engage the swing lock pin. Also engage the swing lock pin when standing on a slope for a long time or whilst the excavator is being transported.

While travelling uphill, keep the lower edge of the bucket approx. 20 to 40cm above the ground. Although the KUBOTA excavator will not slip easily because of the crawlers, it is safer to let the bucket slide over the ground while travelling downhill. Always choose slow speed for uphill and downhill travelling.

[UPHILL TRAVELLING]

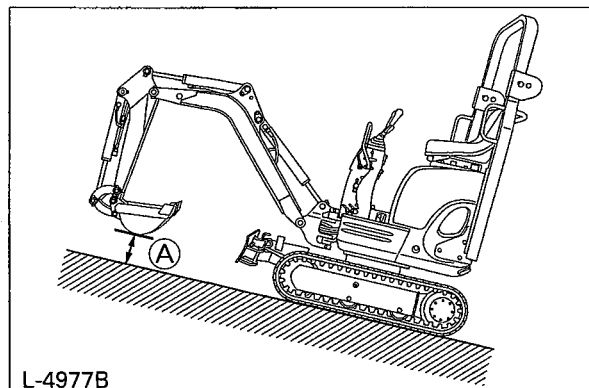

(A) 20 to 40 cm

[DOWNHILL TRAVELLING]

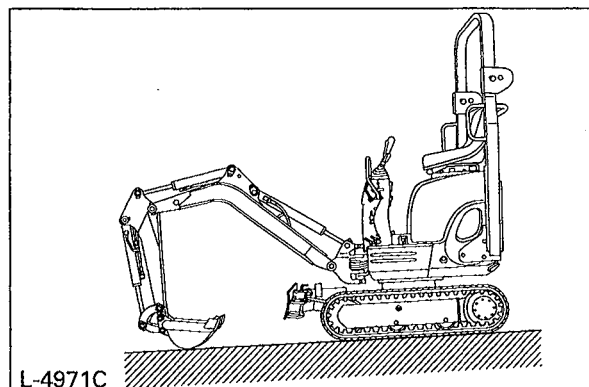

PARKING ON A SLOPE



WARNING

To avoid personal injury or death:

- When the excavator is parked or left unattended on a slope, be sure to put the bucket on the ground and place all control levers in neutral position, then brace the crawlers with chocks.

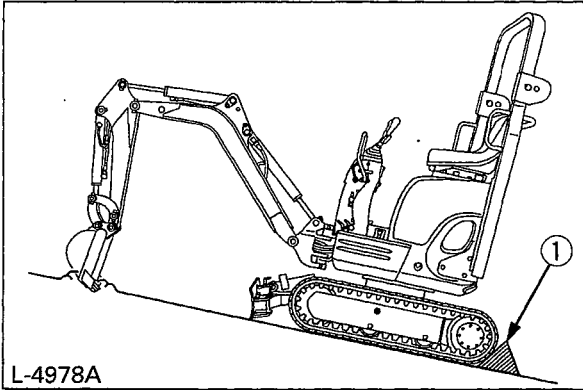

L-4978A

(1) Chock

DRIVE SPEED PEDAL



CAUTION

To avoid personal injury:

- If the travel resistance is high as in running uphill or on an uneven ground, do not use the drive speed pedal.

Operate the travel lever, step on the drive speed pedal, and the vehicle speed will increase. Release the pedal, and the machine will get from the acceleration mode back to the normal speed.

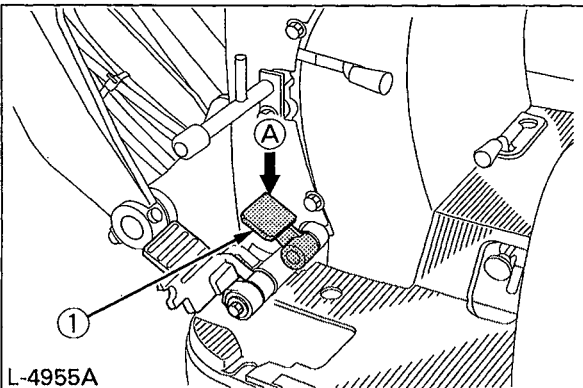

L-4955A

(1) Drive speed pedal (A) "To increase speed push down"

SERVICE PORT OPERATION

This pedal is used to operate attachments such as breakers.

◆ Service port pedal

Step on the service port pedal and pressured oil starts flowing through the "P" port from the control valve. The oil then returns through the "T" port into the tank.

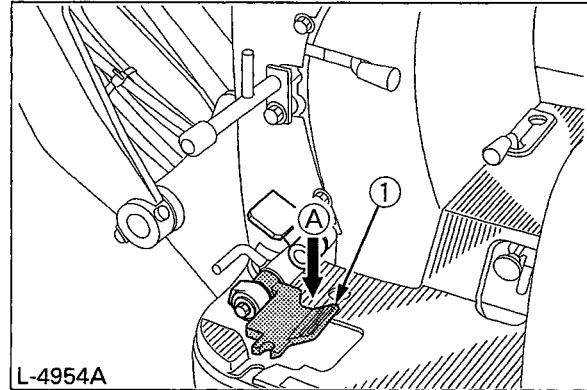

L-4954A

(1) Service port pedal

(A) "Operate"

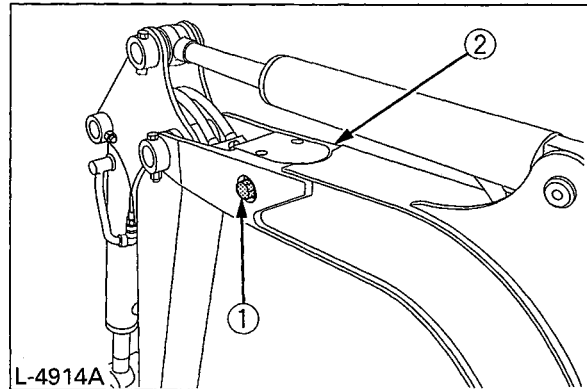

L-4914A

(1) "P" (Pressure) port

(2) "T" (Return) port

NOTE:

- When the service port is not use, put the cover on the pedal. The pedal gets fixed and can be used as footrest.

◆ Locking the service port pedal

The service port pedal can be locked downward in order to use an attachment such as hand breaker and hand auger. Please make a hole to pass the bolt through the floor mat with a knife etc. when you lock the service port pedal. The bolt which fixes the pedal is in the tool kit. Please tighten the bolt until you are able to depress the service port pedal.

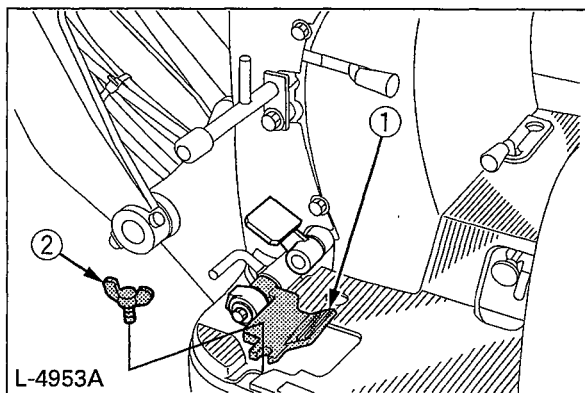

(1) Service port pedal
(2) Bolt

IMPORTANT:

- When the service port is not being used, be careful not to lock the pedal. Because the hydraulic oil temperature will rise abnormally, causing problems with the hydraulic components.

IMPORTANT INFORMATION ON EXCAVATOR OPERATION



CAUTION

To avoid personal injury:

- After work, clean the machine and lubricate all movable parts.
- Check oil level.

IMPORTANT:

- Do not try to crush concrete or boulders using side swings with the bucket. Also avoid using side sweeps of the bucket to move earth piles.

- Under all circumstances avoid the following operations:
 - Excavation using the gravitational impact of the machine.
 - Compacting of gravel or soil using the dropping action of the bucket.
 - Excavation using the travelling power of the machine.
- Do not try to drop or shake of soil adhering to the bucket in the manner shown in the explanation below. This can cause damage to the machine. Adhering soil can be shaken off when the bucket is being emptied by moving the bucket out to the maximum stroke of the cylinder. Should this not suffice, swing out the arm as far as possible and operate the bucket back and forth.
- Do not hit the dozer with the boom cylinder! Make sure that the boom cylinder does not hit the dozer when carrying out deep excavation. If necessary swivel the upper structure so that the dozer is at the back of the machine.
- Pay attention when pulling in the bucket! When pulling in the bucket (for driving or transportation) avoid hitting the dozer.
- Avoid collisions! When moving the excavator, pay attention so that the dozer does not collide with obstructions such as boulders etc.. Such collisions substantially shorten the life span of the dozer and the cylinder.
- Support the machine correctly! When stabilizing the machine with the dozer, lower the whole dozer fully on to the ground.
- If the water or mud level reaches higher than the top of the tracks, the swivel bearing, swivel motor gear and ring gear may be exposed to mud, water and other foreign objects. The excavator must be properly pressure washed after each use.
 - Thoroughly clean the area around the swivel bearing, swivel motor gear and ring gear to remove foreign objects.
 - Inspect the swivel motor oil sump (if equipped) for water contamination. If water is present, refer to operator's manual for lubricant replacement procedure.
 - Refer to operator's manual for proper swivel bearing, swivel motor gear and ring gear lubrication procedures.
 - Reinstall any protective covering if removed earlier.

TRANSPORTING THE EXCAVATOR ON A TRUCK



DANGER

To avoid personal injury or death:

- No directional changes should be made when the excavator is on the ramp. Should a change of direction be necessary, drive off the ramp completely and make the turn.
- When driving forwards or backwards onto the truck, or when swinging the upper body, make sure that neither the cabin or the gates of the truck will be damaged.

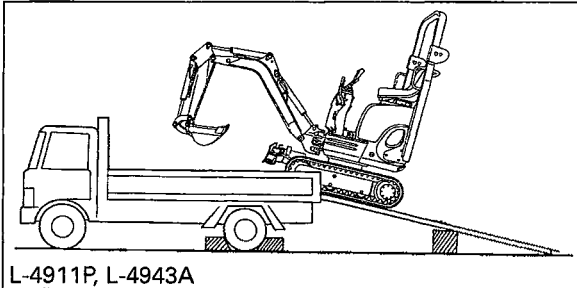

- When the excavator reaches the point between the ramps and the truck bed, halt and then move very slowly until the excavator reaches the horizontal position.
- Move the excavator onto the truck only with the arm completely pulled in. Otherwise the truck cabin could be damaged when swinging the upper body around.
- Do not jack up the machine using its boom to load or unload the excavator from the truck. Dangerous situation could arise.

■ Transporting on a Truck



WARNING

To avoid personal injury or death:

- After loading the machine on the truck, lower the bucket and dozer onto the truck bed. Lock the swing frame with the swing lock pin.

Prepare a platform to load or unload the excavator. Take following steps when using ramps.

1. Apply the parking brakes of the truck, and block the drive wheels from both sides.

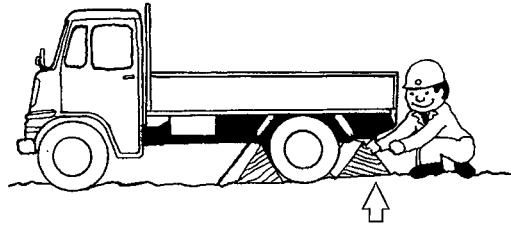

L-0039A

2. Use fixing plates to secure the ramp properly. Connect the ramps directly with the truck bed.

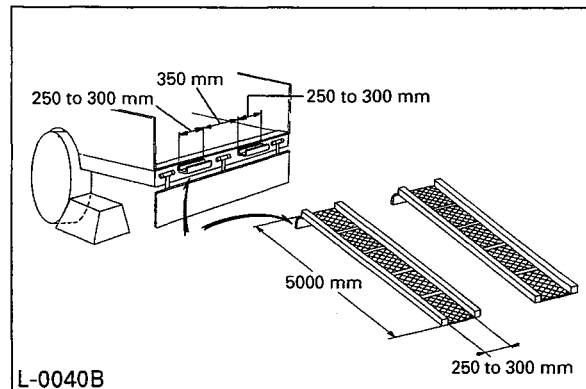

- For additional safety, use blocks or struts under the ramps and the truck bed.

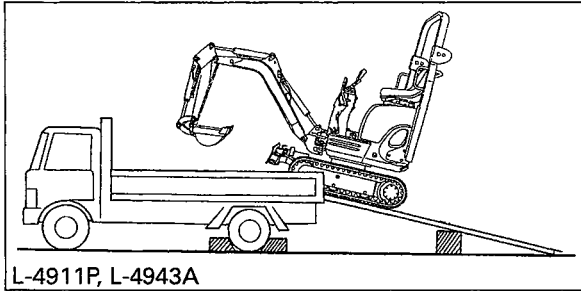

- Completely align the ramps and the crawlers and then drive the excavator slowly up the ramps with the dozer in the front. After ensuring that the crawlers are completely on the truck bed, swivel the upper body around to the back of the truck.
- Lock the swing frame with the swing lock pin.

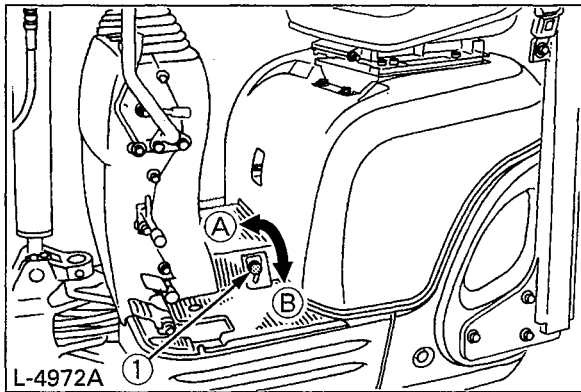

(1) Swing lock pin

(A) "Unlock"

(B) "Lock"

- Block the crawlers and tie down the excavator.

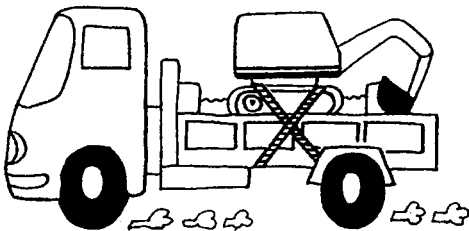

- Before unloading, remove the swing lock pin and then raise the dozer and bucket from the truck bed.

LIFTING OF THE EXCAVATOR



DANGER

To avoid personal injury or death:

- The correct instructions for safe handling are described here. Read these carefully before moving the machine. Make sure that the operating personnel read the operator's manual carefully.

■ **Basics when Lifting with Chains / Straps**

1. The lifting and crane operation is to be undertaken according to the guidelines described.
2. As the accessories for lifting mentioned in this instruction are only given as reference, the standards concerning strength, control and other details are based on the respective applicable guidelines.

■ **Safety Aspects when Lifting with Chains / Straps**

Abide by following steps when lifting:

1. Do not lift loads that exceed the maximum load capacity of the crane.
2. Choose correct tackle suitable to the weight, size and form of the load.
3. First assess the centre of gravity of the load, position the hook directly over the load and lift the load so that the centre of gravity of the load lies as low as possible.
4. The steel wires must be fixed in the middle of the hook.
5. The load must be lifted vertically from the ground.
6. Do not enter the working area under suspended loads and do not move the load over other persons. The load must be moved in an area where the equilibrium can be balanced out easily.

■ Lifting Procedure for the Excavator



WARNING

To avoid personal injury or death.

- Do not lift the excavator other than at the 3 points as illustrated.
- Do not use the ROPS for lifting the excavator.

◆ General guidelines for lifting

1. Lifting position. (see right illustration)
 - 1) Pull in the boom completely towards rear.
 - 2) Pull in the arm completely.
 - 3) Pull in the bucket completely.
 - 4) Swing the boom 0.17 to 0.26 rad. (10 to 15 degrees) to the right from the central position.
 - 5) Insert the swing lock pin.
2. Attaching the chains / straps.
 - 1) Always hook the excavator at three points. (one on the boom and right and left of the dozer blade)
 - 2) Always use a shackle on each lifting hole when attaching the straps.
 - 3) Use cushioning material at all places where the straps contact the machine.
3. Tackle

Choose components with enough strength.
4. Lifting
 - 1) Lift slowly and safely
 - 2) Do not enter the excavator area when lifting.
 - 3) Lift the excavator horizontally. (Modify connections according to needs)

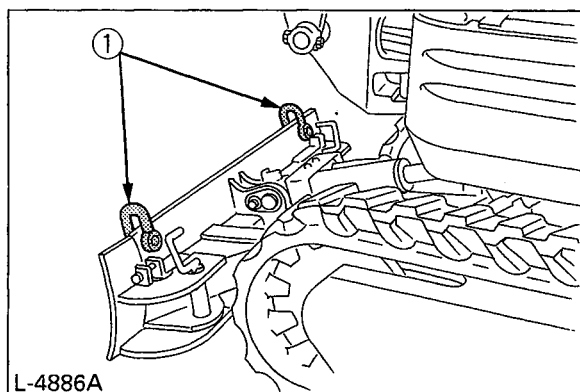
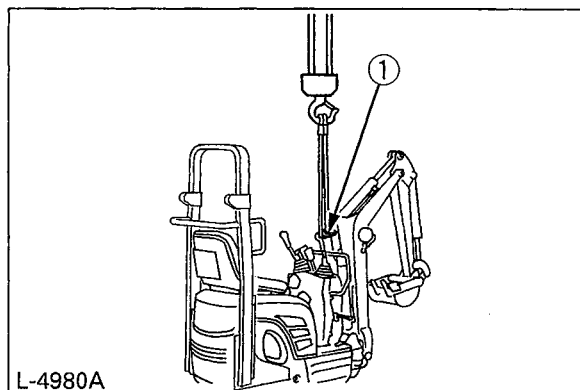

(1) Shackle

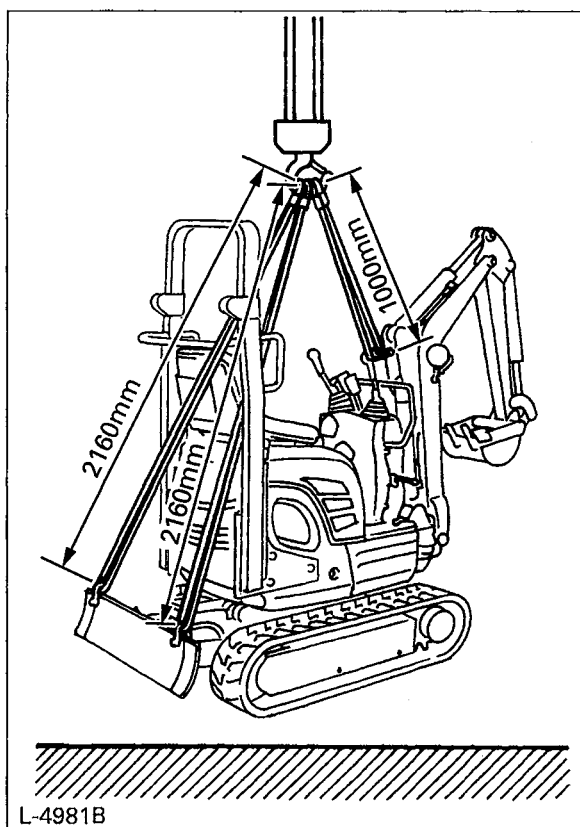

MAINTENANCE

MAINTENANCE INTERVALS

No.	Checkpoints	Intervals	Hour meter indicator														Consequently	Ref. page
			50	100	150	200	250	300	350	400	450	500	550	600	1000	2000		
1	Fuel	check	Daily check															45
2	Engine oil	check	Daily check															46
		change	○		○		○		○		○		○				every 100 hrs	51
3	Hydraulic oil**	check	Daily check															46
		change													○		every 1000 hrs	54,55
4	Coolant	check	Daily check															44
		change															every 2 years	57
5	Lubrication points	check	Daily check															47
6	Radiator	check	Daily check															48
7	Battery condition	check	○	○	○	○	○	○	○	○	○	○	○	○	○	○	every 50 hrs	49,50
8	Electrical lines	check	Daily check, Annual servicing															48,56
9	Greasing of swing bearing teeth	—	○	○	○	○	○	○	○	○	○	○	○	○	○	○	every 50 hrs	50
10	Fan belt tension	adjust			○				○					○	○	○	every 200 hrs	52
11	Radiator hoses and clamps	check			○				○					○	○	○	every 200 hrs	52
		change															every 2 years	56
12	Air filter element*	clean			○				○					○	○	○	every 200 hrs	53
		change												○	○		every 1000 hrs	56
13	Greasing of swing ball bearings				○				○					○	○	○	every 200 hrs	54
14	Fuel pipes and hoses	check			○				○					○	○	○	every 200 hrs	—
		change															every 2 years	57
15	Engine oil filter	change	○			○			○								every 200 hrs	52,53
16	Fuel filter	check	○	○	○	○	○	○	○	○	○	○	○	○	○	○	every 50 hrs	49
		change									○			○	○		every 500 hrs	54
17	Hydraulic return filter element	change												○	○	every 1000 hrs	54 55	
18	Hydraulic suction filter element	change												○	○	every 1000 hrs	54 55	
19	Front idler and track roller oil	change													○	every 2000 hrs	56	
20	Dynamo and starter motor	check													○	every 2000 hrs	56	
21	Radiator system	rinse														every 2 years	57	
22	Fuel injection nozzle (Injection pressure)	check														every 1500 hrs	56	
23	Injection pump	check														every 3000 hrs	56	

IMPORTANT:

- * Clean the air filter more frequently if used in dusty conditions. With heavy soiling, replace the filter.
- ** When using a hydraulic breaker, change hydraulic oil and return filter according to the table on "Hydraulic Oil Change (Including Exchange of the Suction Filter in the Hydraulic Tank) under "EVERY 1000 SERVICE HOURS" in "REGULAR CHECKS AND MAINTENANCE WORK".
- The items listed above (@ marked) are registered as emission related critical parts by KUBOTA in the U.S.EPA nonroad emission regulation. As the engine owner, you are responsible for the performance of the required maintenance on the engine according to the above instruction.
Please see the Warranty Statement in detail.

OPENING AND CLOSING OF PARTS

■ Opening/Closing of the Engine Bonnet



CAUTION

To avoid personal injury:

- Do not open the engine bonnet before stopping engine.
- Do not touch the exhaust muffler or the exhaust pipe; serious burns can occur.

For opening, pull up the lever and open the bonnet.

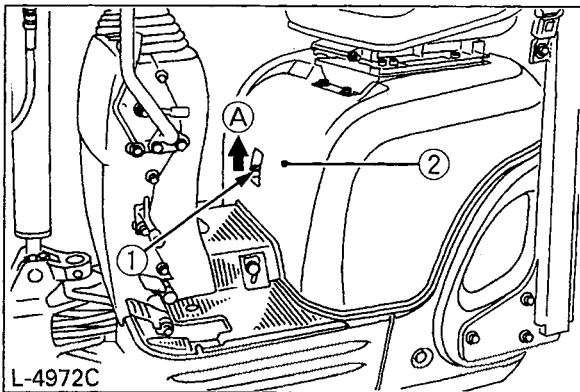

(1) Lever

(A) "Open"

(2) Engine bonnet

■ Keep the Tools and Operator's Manual in the Toolbox

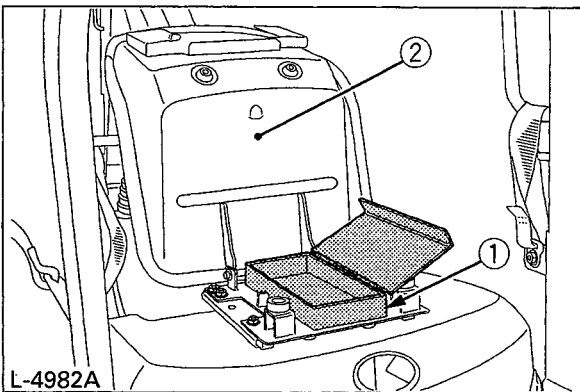

(1) Tool box

(2) Operator's seat

DAILY CHECKS

For your own safety and to assure the long life span of your machine, a careful check should be made before each operation.

■ Coolant Check



CAUTION

To avoid personal injury:

- Move the excavator on to even ground.
- Make sure that the engine is turned off.
- Do not open the radiator cap immediately after the engine has been stopped; Serious burns can occur with squirting hot coolant fluid.
- Check the coolant level in the reserve tank only after the engine has cooled down.
- Remove the radiator cap only if absolutely necessary.

The radiator has a reserve tank. Should the coolant level in the radiator sink, the water will be automatically be forwarded to the radiator.

Check the coolant level in the reserve tank and fill up if necessary. The coolant level should be between the marks "FULL" and "LOW".

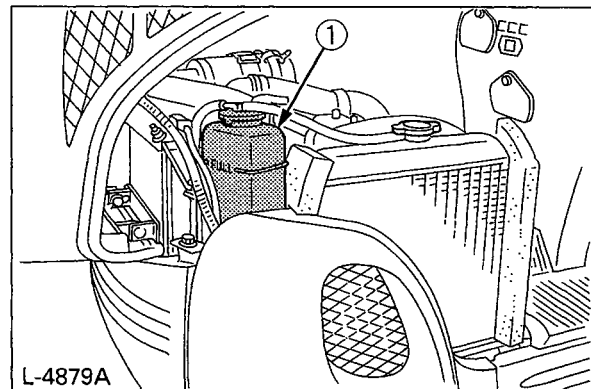

(1) Reserve tank

IMPORTANT:

- Before delivery coolant was filled with 50 % water and 50 % antifreeze.
- Do not fill with dirty or salty water.

Check Fuel Level



CAUTION

To avoid personal injury:

- Stop the engine before fuelling.
- Do not smoke while fuelling.

IMPORTANT:

- With temperatures over 23°F (-5°C), use No.2-D diesel fuel, while with temperatures under 23°F (-5°C), use No.1-D diesel fuel.
- Make sure that the fuel tank is not run empty. Air enters into the fuel system, and must be purged before restarting.

1. Check the fuel level in fuel tank.
2. Open the tank cap, and fill with fuel.

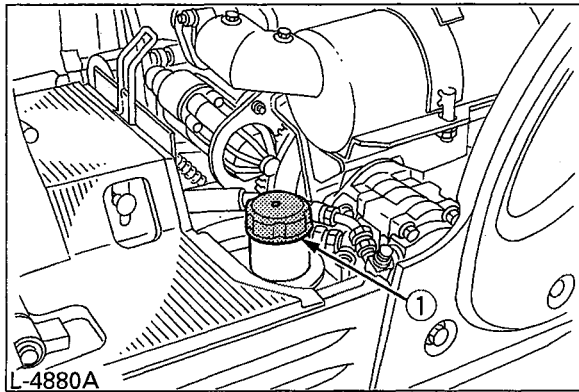

(1) Tank cap

Fuel tank capacity	11 L
--------------------	------

IMPORTANT:

- Always fill up fuel after a day's work.
- See "PURGING OF THE FUEL SYSTEM" in "OTHER ADJUSTMENTS AND REPLACEMENTS".
- Fuel tank cap has an air breather. Make sure to clean the air breather when filling up with fuel.

If the air breather is clogged with mud, the fuel tank becomes under-pressurized.

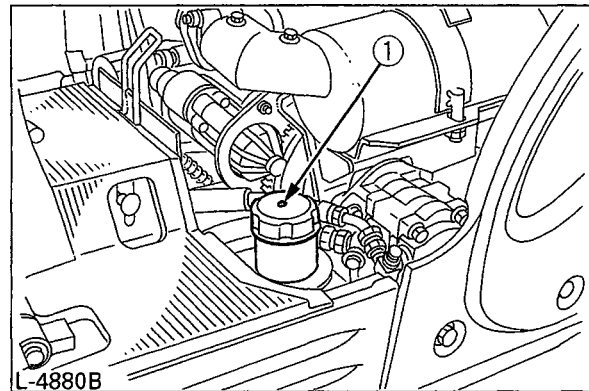

(1) Air breather

■ Check Engine Oil Level



CAUTION

To avoid personal injury:

- Stop the engine before checking the oil level.

Insert the oil gauge rod fully into the prepared opening, remove again and check the oil level; if necessary fill with oil. The machine must be on level ground when checking the oil level.

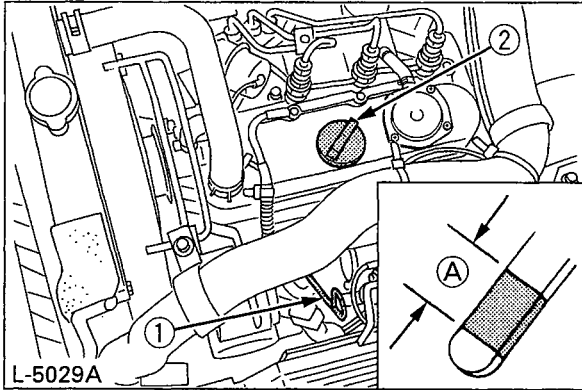

(1) Oil gauge
(2) Filling port

(A) Required level

IMPORTANT:

- Use engine oil with the correct viscosity. (according the outside temperature)
- After stopping the engine, wait five minutes, then check oil level. (Excavator must be on level ground.)

■ Check Hydraulic Oil Level



CAUTION

To avoid personal injury:

- First lower all attachments on the ground then stop the engine.

IMPORTANT:

- Before filling with oil, wipe away all sand and dust from around the oil port. Make sure you use an identical type of hydraulic fluid.
- The excavator has been filled with hydraulic fluid before delivery. See "RECOMMENDED OILS". (Do not mix different makes!)

1. Move the excavator on to level ground. Extend every cylinder rod up to its centre position, track width increases 860 mm and place the bucket in contact with the ground.
2. Check the oil level as to whether it lies on the centre mark under normal temperature 50 to 86°F (10 to 30°C).
3. Enough oil is present if the oil level lies between the markings.
4. Should the oil level be too low, fill with oil through the oil port before starting the engine. This step is important for the protection of the hydraulic system.

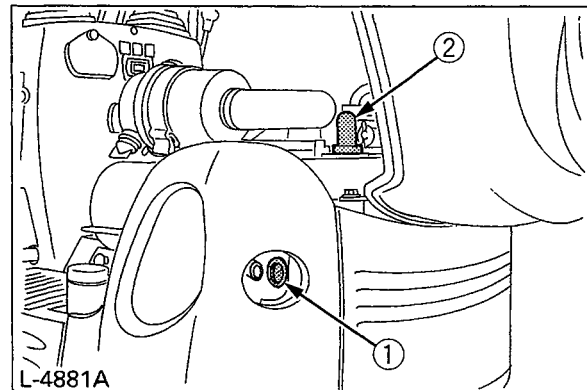

(1) Specified oil level
(2) Tank cap

Lubrication Points



CAUTION

To avoid personal injury:

- First lower all attachments on the ground then stop the engine.
- While greasing, take care not to step on the bucket teeth.
- When doing excavation work in water, generously grease the following points. After finishing work, grease again.

Grease the marked grease nipples shown by arrows in the illustration below.

1. Boom bottom linkage..... 1 place
2. Arm bottom linkage 1 place
3. Boom cylinder boss..... 2 places
4. Arm cylinder boss 2 places
5. Bucket cylinder pin 1 place
6. Boom swing fulcrum 2 places
7. Swing cylinder boss 1 place
8. Dozer linkage pin 2 places
9. Dozer cylinder boss 1 place
10. Bucket link pin 2 places

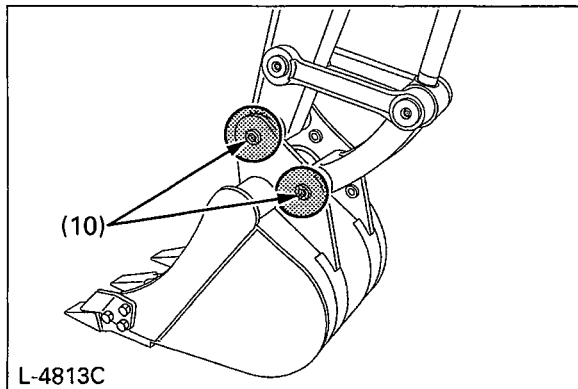
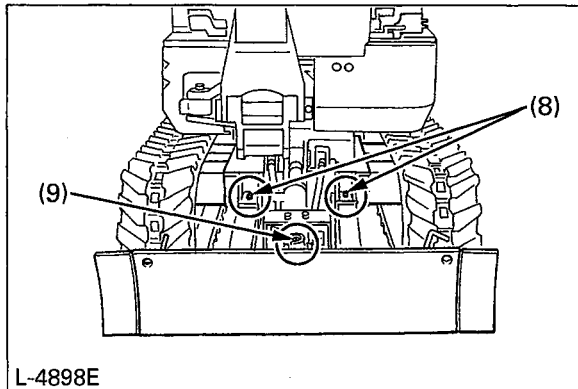
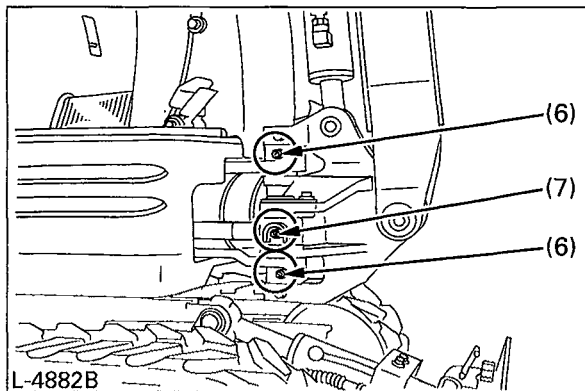
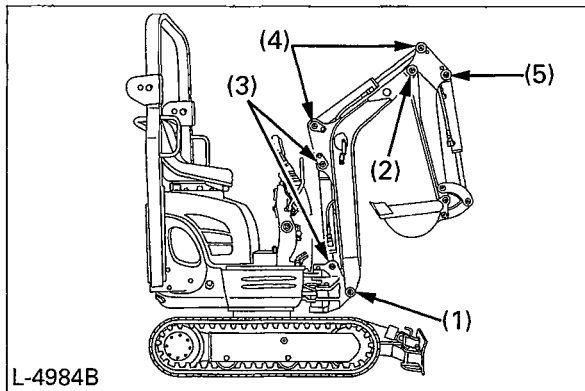

■ Check Radiator



CAUTION

To avoid personal injury:

- Always stop the engine before checking the radiator.
- Wear eye protection when cleaning with compressed air.

1. Check if the fins and ribs are clogged. If so clean with compressed air or steam.
2. Check the rubber hoses for damage and replace if cracked or old. Check if the hose clamps are tight enough.

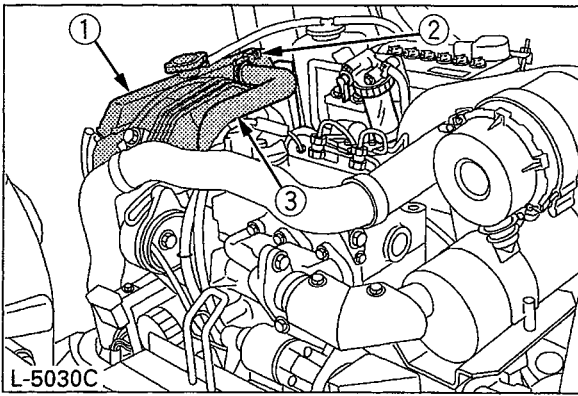

(1) Radiator

(2) Hose clamps

(3) Rubber hoses

IMPORTANT:

- Radiator fins and ribs must be clean in order not to overheat the engine and allow free flow of air through the cooling elements.

■ Cleaning of Engine and Electrical Wiring



CAUTION

To avoid personal injury:

- Always stop the engine before cleaning the wiring, cables and engine.

Before starting, check whether flammable substances have gathered on the battery, the cables and wiring, the muffler or on the engine. Remove thoroughly.

■ Checking the Electrical Circuit

Check the electrical circuitry for disconnections, shorts or loose terminals.

■ Washing the Whole Machine

IMPORTANT:

- Do not wash the excavator with the engine running. Water could enter the air filter and damage the engine. Make sure that the air filter is kept dry.

REGULAR CHECKS AND MAINTENANCE WORK

EVERY 50 SERVICE HOURS

■ Draining the Fuel Tank

Loosen the drain plug at the bottom of the fuel tank to let sediments, impurities and water out of the tank. Finally tighten up the plug.

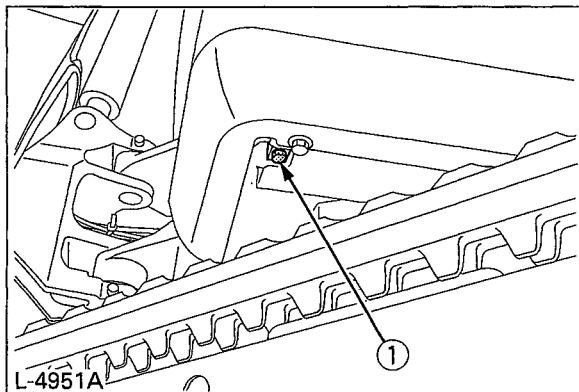

(1) Drain plug

■ Draining of the Fuel Filter



CAUTION

To avoid personal injury:

- Before draining the fuel filter, be sure to stop the engine.
- Do not smoke during inspection.

Check if water or impurities are in the fuel filter cup, if so clean inside of cup with light oil. For details see the chapter on "Fuel Filter Change".

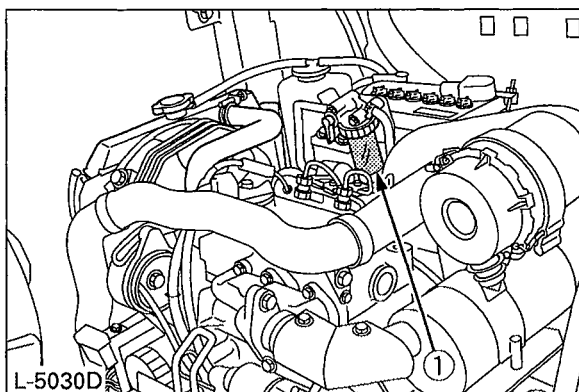

(1) Fuel filter cup

■ Battery Service



CAUTION

To avoid personal injury:

- Batteries contain sulphuric acid which can cause severe burns. Avoid all contact with skin, eyes or clothing. Antidote - External: Rinse with plenty of water. Internal: Drink large quantities of water or milk. Call a physician immediately. Eyes: Rinse with plenty of water for 15 minutes and get prompt medical attention. Keep batteries out of the reach of children.
- Before inspection or dismantling the battery, be sure to turn off the engine and turn the starter switch to the "OFF" position.
- When removing the battery, always disconnect the negative ground cable first. The reverse when installing a battery, always connect the ground cable last. This prevents a possible explosion caused by sparks.
- Always wear eye protection when working with the battery.

1. Check the battery fluid level and add distilled water if necessary.
2. Should battery fluid be spilt, fill with sulphuric acid solution of the same concentration.
3. Clean the battery caps (ventilation holes) also.

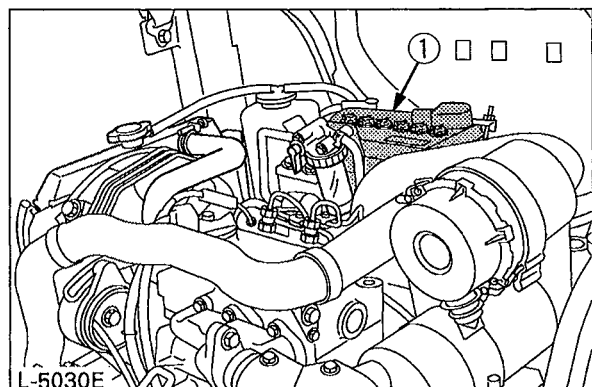

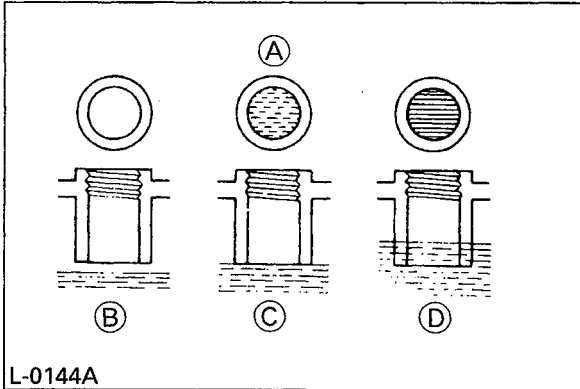

L-0144A

(1) Battery

(A) Battery fluid level

(B) "Too low"

(C) "Correct"

(D) "Too high"

Battery Charging



To avoid personal injury:

- When the battery is being activated, hydrogen and oxygen gases in the battery are extremely explosive. Keep open sparks and flames away from the battery at all times, especially when charging the battery.
- When charging battery, remove battery vent plugs.
- When disconnecting the cable from the battery, start with the negative terminal first. When connecting the cable to the battery, start with the positive terminal first.
- Do not check battery charge by placing a metal object across the terminals.
Use a voltmeter or hydrometer.

1. Make sure each electrolyte level is to the bottom of vent wells. If necessary add distilled water in a well-ventilated area.
2. The water in the electrolyte evaporates during recharging. Liquid shortage damages the battery. Excessive liquid spills over and damages the excavator body.
3. To slow charge the battery, connect the battery positive terminal to the charge positive terminal and the negative to the negative, then recharge in the standard fashion.

4. A boost charge is only for emergencies. It will partially charge the battery at a high rate and in a short time. When using a boost-charged battery, it is necessary to recharge the battery as early as possible. Failure to do this will shorten the battery's service life.
5. When the specific gravity of electrolyte reaches between 1.27 and 1.29 the charge is completed.
6. When exchanging an old battery for new one, use battery of equal specification.

Greasing of Swing Bearing Teeth

1. Fill with grease through the grease nipple (at the right end side).
2. Grease at each 90° (1.58 rad.) position of the swing frame.
3. Fill with approx. 50g of grease (approx. 20 pumps with the grease gun). Distribute the grease over the teeth.

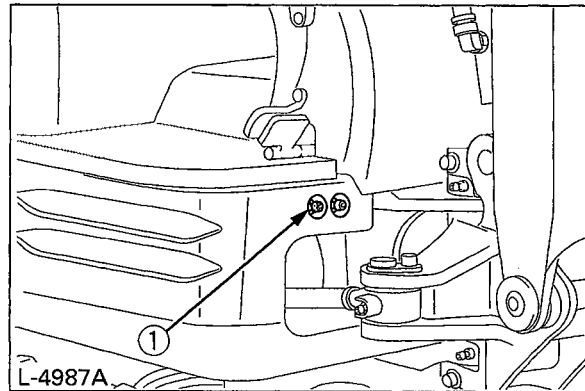

(1) Grease nipple (for Bearing teeth)

L-4987A

EVERY 100 SERVICE HOURS

Do all 50 hour servicing at the same time.

■ Engine Oil Change (First Engine Oil Change after 50 Service Hours)



CAUTION

To avoid personal injury:

- First stop the engine and wait long enough for the oil to cool down.

1. Remove the drain plug on the underside of the engine and drain all oil.
2. Re-tighten the drain plug.

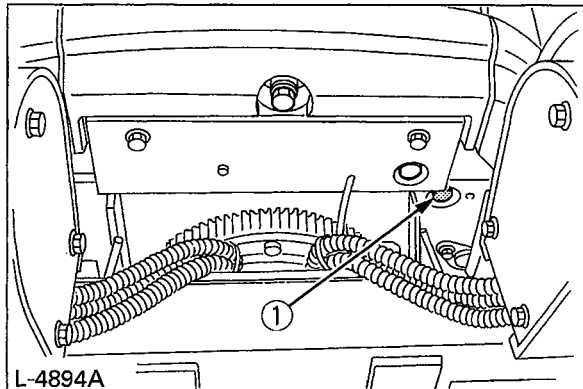

(1) Drain plug

3. Fill with new oil up to the required level.

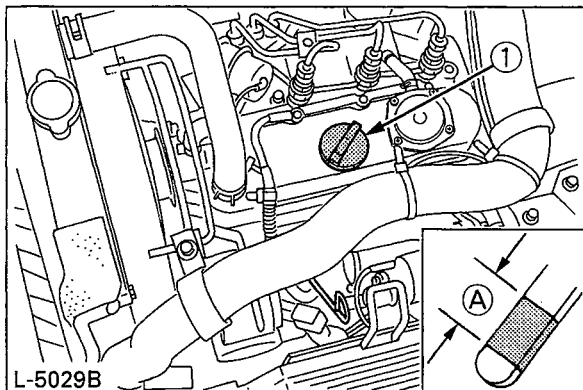

(1) Oil filling port

(A) Required level

4. Let the engine idle for approx. 5 min. Check the engine oil level. To check the engine oil level, insert the oil gauge completely into the respective port opening and pull out again. If the oil level lies between both markings, no oil must be added.

IMPORTANT:

- Regardless of the service hours, an engine oil change is due every six months.

Engine oil volumes (with engine oil filter)	approx. 2.2 L
--	---------------

EVERY 200 SERVICE HOURS

Do all 50 hour servicing at the same time.

■ Checking the Fan Belt Tension

◆ Check and adjustment of the fan belt tension



CAUTION

To avoid personal injury:

- First stop the engine.
- After servicing, make sure to replace the belt cover in its original position.

1. Press the fan belt ④ down in the middle, with a force of approx. 10 kg. The belt tension is correct if it deflects about 8 mm. If otherwise, loosen bolt ① and ② and shift the dynamo ③ in the direction shown by the arrow.
2. Replace the fan belt if worn out, cracked or torn.

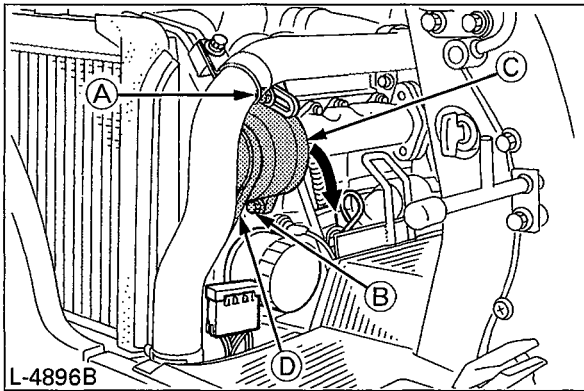

IMPORTANT:

- If the engine is run with a loose fan belt, the belt could slip and cause overheating of the engine or insufficient battery charging. Check fan belt tension regularly.
- Should the fan belt snap or jump out, the lamp for battery charge will light up. Stop the engine immediately.

■ Checking the Radiator Hoses



CAUTION

To avoid personal injury:

- Wait long enough for the radiator coolant to cool down.

Check the water hoses are properly attached. This check should be carried out every 200 hours or every 6 months, whichever comes first.

1. Should the hose clamps be loose or water leak, tighten the hose clamps properly.
2. Should the radiator hoses be swollen, aged or cracked, they must be replaced and the hose clamps tightened again properly.

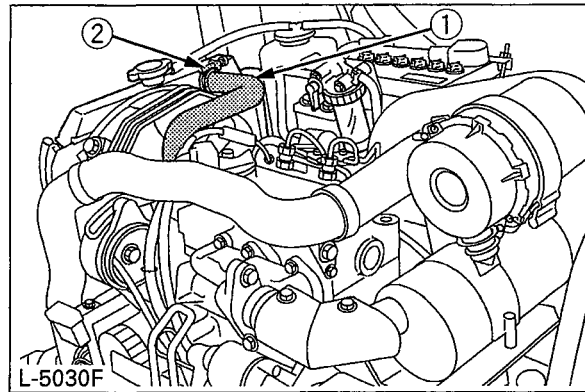

(1) Radiator hoses

(2) Hose clamps

■ Replacing Engine Oil Filter (First Engine Oil Filter Change after 50 Service Hours)

1. Remove the cartridge with the supplied filter wrench.

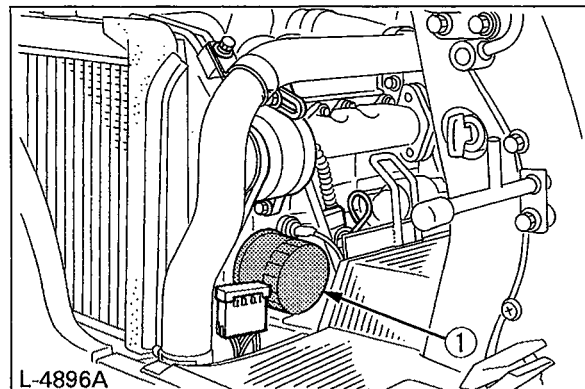

(1) Oil filter cartridge

2. Oil the O-ring of the new oil filter cartridge lightly. Then tighten the oil filter cartridge by hand.
3. Fill engine oil to the specified level.
4. Let the engine run for approx. 5 min. and make sure that the engine oil control lamp does not light up. Then stop the engine.
5. The engine oil level will sink parallel to the oil filter capacity after the engine is started. It is necessary to add oil.

IMPORTANT:

- Always check the oil level when replacing the filter.

Inspection and Cleaning of the Air Filter Element

Open the engine bonnet and remove the dust-cover. Take out only outer element, clean the element, case interior and reassemble. During reassembly, take care to install the dust-cover so that its TOP mark (arrow) faces upwards. Do not remove the inner element.

IMPORTANT :

- Should the machine be used in extremely dusty areas, the air filter element must be inspected and cleaned more frequently than in the specified maintenance periods.
- The air filter has a dry element, keep free from oil.
- Do not run the engine without the air filter.

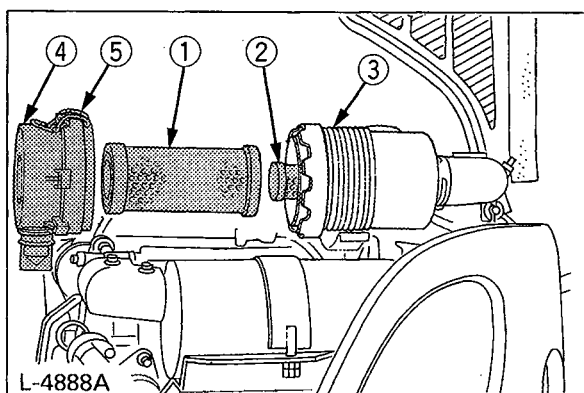

- (1) Outer element
 (2) Inner element
 (3) Case
 (4) Dust-cover
 (5) Clamps

Air Filter Maintenance



CAUTION

To avoid personal injury:

- Wear eye protection.

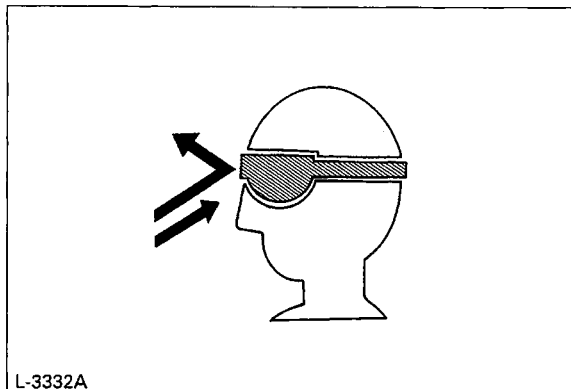

L-3332A

◆ Cleaning with compressed air

Pressure of compressed air must be under 205kPa(2.1kgf/cm²), and the cartridge should be blown clean from the inside to the outside until the dust deposits are completely clear.

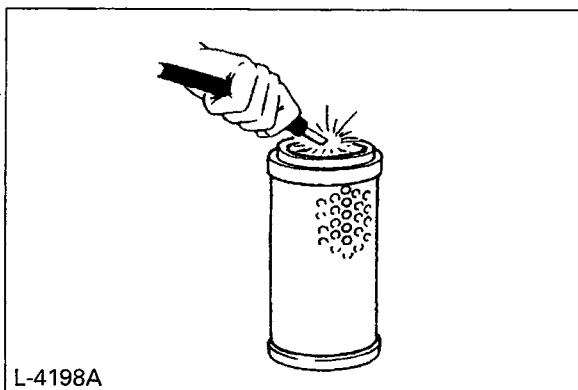

L-4198A

IMPORTANT:

- If the air suction is still inadequate, or the colour of the exhaust gases is abnormal even after the cleaning, the air filter element must be replaced.

■ Greasing of the Swing Bearing

1. Grease through the respective grease nipple.
2. Grease at each 90° (1.58 rad.) position of the swing frame.

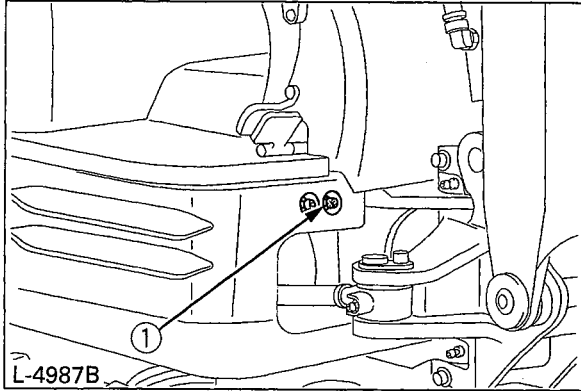

(1) Grease nipple

■ Checking Fuel Line and Intake Air Line

1. Check to see that all lines and hose clamps are tight and not damaged.
2. If hoses and clamps are found worn or damaged, replace or repair them at once.

EVERY 500 SERVICE HOURS

Do all 50 hour servicing at the same time.

■ Replacing Fuel Filter Element



CAUTION

To avoid personal injury:

- Keep away from fire.

1. Close the fuel cock.

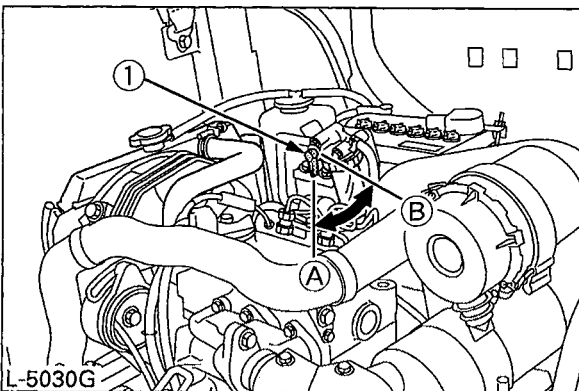

(1) Fuel cock

(A) "Open"

(B) "Closed"

2. Unscrew the retaining ring and remove the filter cup. Clean the inside of the cup with light oil.
3. Remove and replace the element with new one into position and tighten a up by hand.
4. Reassemble the filter cup and the retaining ring.
5. Open the fuel cock again.

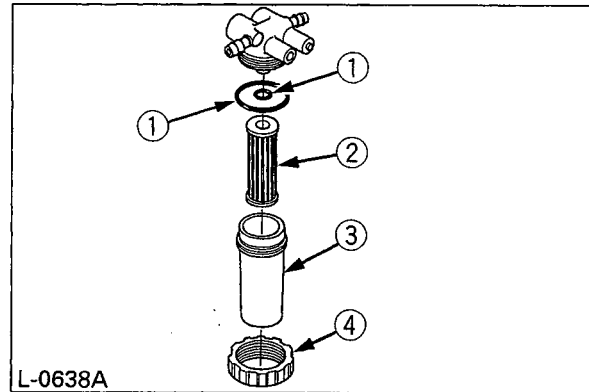

(1) O rings

(2) Element

(3) Filter cup

(4) Retaining ring

IMPORTANT:

- After replacement of the element, the fuel system must be purged.

EVERY 1000 SERVICE HOURS

Do all 50, 200 and 500 hour servicing at the same time.

■ Hydraulic Oil Change (Including Replacing of the Suction Filter and the Return Filter in the Hydraulic Tank)

NOTE:

Contact your KUBOTA dealer for details.

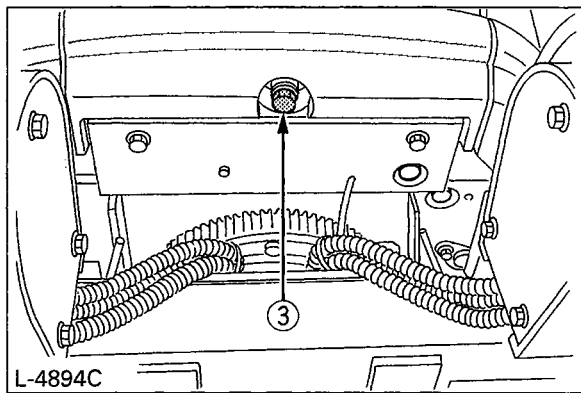
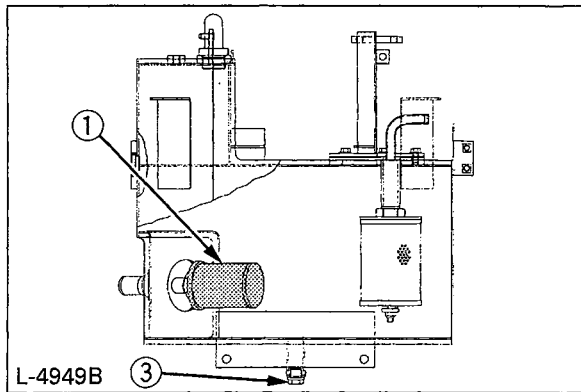
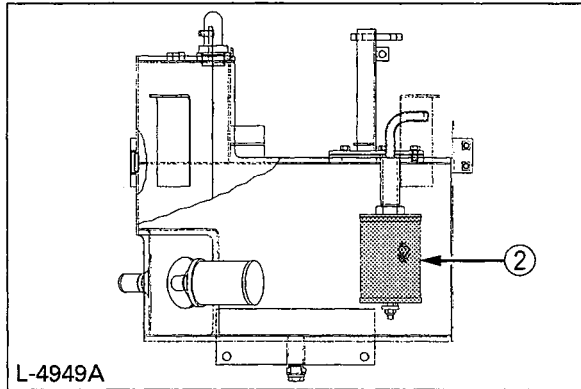

- (1) Suction filter
- (2) Return filter
- (3) Drain plug

Hydraulic oil volumes	Hydraulic tank	approx. 12.4 L
	Whole oil volumes	approx. 14.4 L

Hydraulic Oil Check with Hydraulic Breakers

The hydraulic oil change after 1000 operating hours in the operator's manual is based on the type of work done. The following inspection measures are valid when hydraulic breakers are used:

1. Changing and filling up of hydraulic oil
 - 1) The hydraulic oil must be changed more often when breakers are used because the machine is subject to harder conditions than at normal excavating work.
 - 2) Use only the recommended oils mentioned in the operator's manual when changing or topping up oil.
 - 3) When filling up oil, do not mix oils of different makes.
2. Changing the return filter and oil
 - 1) The filter must be changed more often because of contamination resulting from the frequent assembly and disassembly of the hoses.
 - 2) Use the correct replacement filter.
 - 3) Oil change according to operating hours.

		Hydraulic oil Return Filter	Suction Filter
Normal excavator work		every 1000 Hrs.	1000 Hrs.
Breaker work portion	20%	every 800 Hrs.	
	40%	every 400 Hrs.	
	60%	every 300 Hrs.	
	more	every 200 Hrs.	

EVERY 1000 SERVICE HOURS OR ONCE A YEAR

■ Replacing Air Filter Element

Open the engine bonnet and remove the dust-cover.

Remove and replace the outer element and inner element with new elements.

When reassembling, install the dust-cover so that its TOP mark (arrow) faces up-wards.

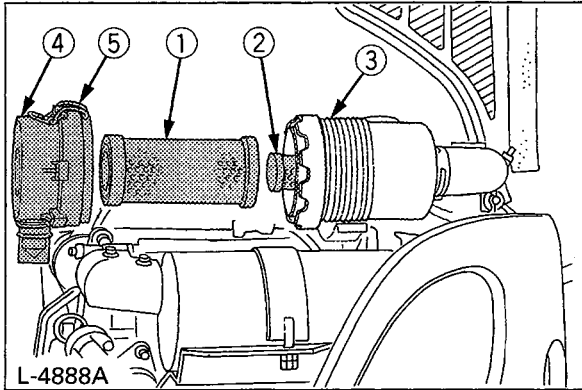

- (1) Outer element
 (2) Inner element
 (3) Case
 (4) Dust-cover
 (5) Clamps

IMPORTANT:

- Shorten the replacement period if using in lots of dust or sandy areas.

EVERY 1500 SERVICE HOURS

■ Checking Fuel Injection Nozzle (Injection Pressure)

Consult your local KUBOTA Dealer for this service.

EVERY 2000 SERVICE HOURS

Do all 50, 200, 500 and 1000 hour servicing at the same time.

■ Changing Front Idler and Track Roller Oil

NOTE:

Contact your KUBOTA dealer for details.

■ Checking the Dynamo and Starter Motor

NOTE:

Contact your KUBOTA dealer for details.

EVERY 3000 SERVICE HOURS

■ Checking Injection Pump

Consult your local KUBOTA Dealer for this service.

ANNUAL SERVICING

■ Electrical Wiring and Fuses

Check the terminals periodically for proper connections. Loose wiring or damaged cables can cause improper functioning of the electrical system. Short circuiting, electrical leaks and other expensive problems could arise. Check wiring and replace damaged components immediately. If a fuse blows out soon after having been replaced, contact your nearest KUBOTA dealer. Never use a fuse other than specified.

BIENNIAL SERVICING



CAUTION

To avoid personal injury:

- Do not loosen the radiator cap before the radiator has cooled down sufficiently. Then only loosen the cap and allow enough time for the pressure in the system to be released. Now remove the cap completely.

■ Replacement of Radiator Hoses

Replace radiator hoses and hose clamps ever two years. If the hoses are swollen, hard or cracked, they must be replaced earlier.

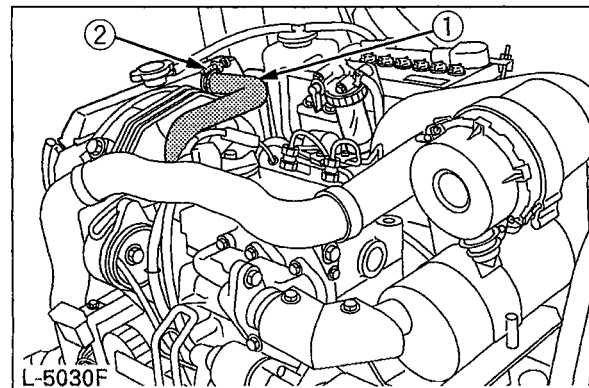

- (1) Radiator hoses
 (2) Hose clamps

■ Changing Radiator Coolant

(In case of long-life coolant fluid)

Stop the engine and wait until it has cooled down completely.

1. Open the drain plugs on the bottom of the radiator and drain coolant completely.
2. To clean, rinse the radiator with water.
3. Close the drain plug and fill the radiator with coolant fluid. Let the engine idle for about 5 min., stop the engine and check the coolant level.
4. The machine has been shipped filled with 50% anti-freeze solution.

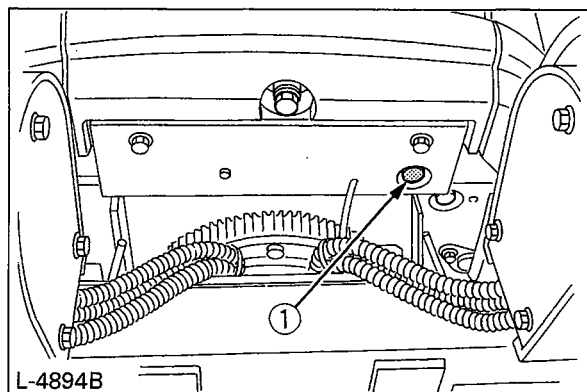

(1) Drain plugs

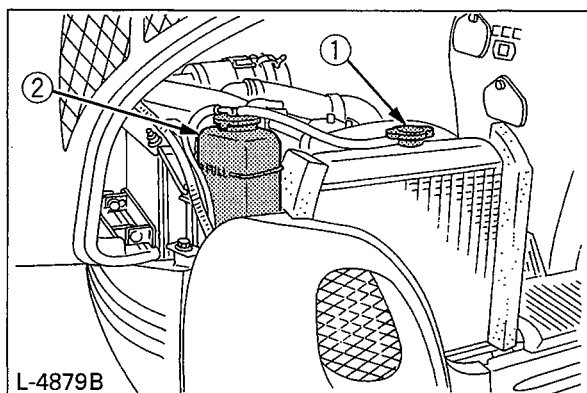

(1) Radiator cap
(2) Reserve tank

Radiator	approx. 2.3 L
Reserve tank	approx. 0.5 L

IMPORTANT:

- Do not operate the engine without coolant.
- To fill the radiator system use fresh water and anti-freeze fluid.
- When the anti-freeze is mixed with water, the ratio must not exceed 50%. (a 50/50 mix is recommended)
- Tighten the radiator cap properly. If the cap is loosely or not properly fitted, overheating of the engine can result due to coolant fluid loss.

■ Replacing Fuel Hose

Replace the hoses and clamps.

(See "Checking Fuel and Intake Air Line" every 2000 hours maintenance.)

■ Replacing Intake Air Line

Replace the hoses and clamps, if necessary.

(See "Checking Fuel and Intake Air Line" every 2000 hours maintenance.)

OTHER SERVICING

■ Cleaning the Track Frame Telescopic Beams

When the track frame telescopic beams are clogged or covered with soil or sand, clean the slide pipes as follows according to need.



WARNING

To avoid the personal injury or death:

- Place the machine on even ground when cleaning the track frame telescopic beams.

1. First lift the machine off the ground using the dozer blade and boom functions.
2. Switch the track width change / dozer select lever to the "Track width change" position.
3. Pull the control lever backward, and expand the track width to 860mm.
4. Remove soil and sand adhered to the telescopic beams, then put grease evenly around the pipes. Make sure all 4 telescopic beams are greased.
5. Retract and expand the track width repeatedly a few times by moving the control lever, so that the grease is spread adequately.
6. Switch the track width change / dozer select lever to the "Dozer" position.
7. Place the machine down on the ground carefully by moving the dozer blade and the boom.

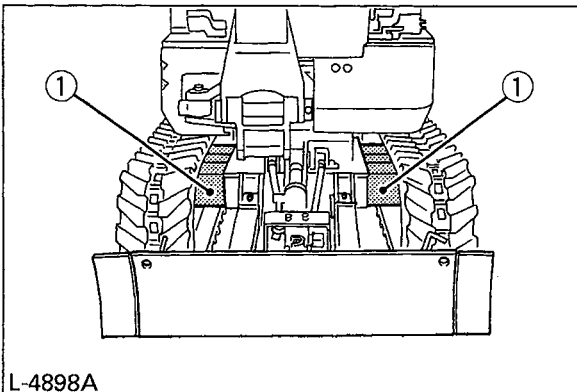

L-4898A

(1) Track frame telescopic beams

OTHER ADJUSTMENTS AND REPLACEMENTS

PURGING OF THE FUEL SYSTEM

1. Fill up the excavator with fuel.
2. Turn the starter key to the position "ON".
3. The air in the fuel system will be purged within one minute.

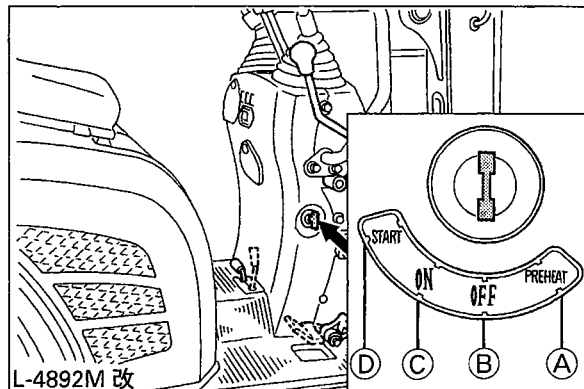

- (A) "PREHEAT"
 (B) "OFF"
 (C) "ON"
 (D) "START"

IMPORTANT:

- If the purging was insufficient, and the engine dies immediately after starting. In this case repeat steps (2) to (3) again.

ADJUSTMENT OF CRAWLERS

- ◆ To loosen the crawlers, follow the following procedure:



CAUTION

To avoid personal injury:

- Do not loosen the grease nipple completely or too quickly. Otherwise grease under high pressure in the tension cylinder could squirt out.
- Do not crawl under the excavator.

1. Using a socket wrench, loosen the grease nipple a few turns.

2. When grease oozes out from the thread, rotate the crawler and loosen the crawler in the lifted position (see illustration).

After adjustment is completed:

Using the socket wrench, tighten the grease nipple.

Tightening torque must be between 98 to 108 N·m (10 to 11 kgf·m).

IMPORTANT:

- If the crawlers are too tight, wear is increased.
- If the crawlers are too loose, the crawler shoes may collide with the sprocket, and wear is increased.
The crawler may dislocate or come off.
- Clean the crawler after every use.
- Should the crawler tension be heightened due to mud sticking, lift the crawler with the help of the boom, arm and bucket, idle the engine and remove the mud from the crawler, especially from the openings of the link plate, carefully.

◆ Tension the crawlers as specified:

1. Apply grease (2) to the grease nipple (1).

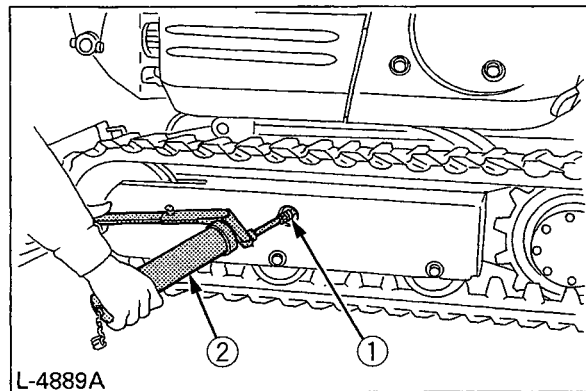

- (1) Grease nipple
 (2) Grease gun

- Tension the crawler in the lifted position, so that the distance "A" (clearance between the track roller and the inside surface of the crawler) is 10 to 15mm (see illustration), (In this case, the crawler seam is positioned on the top centre between the idler and the sprocket.

**DANGER**

To avoid serious injury or death:

- Do not work under the machine in this condition.
- For your safety do not rely on hydraulically supported devices, they may leak down suddenly drop or be accidentally lowered.

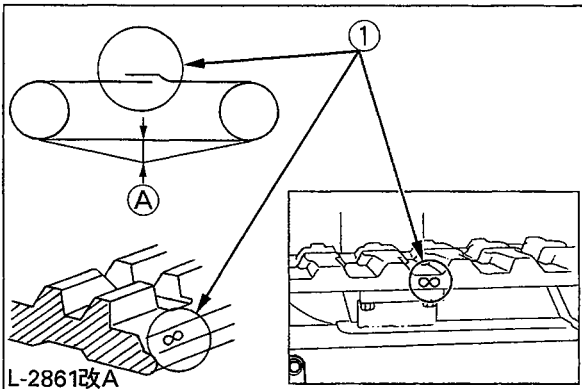
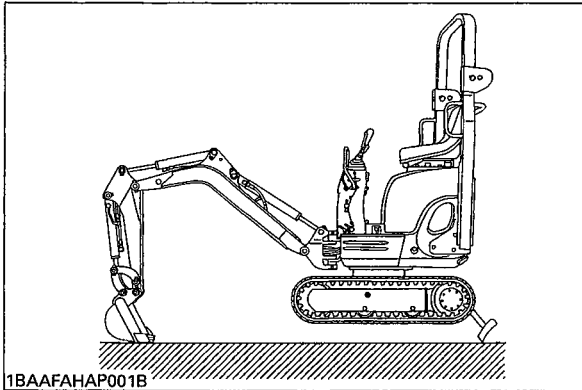

(1) Seam (Mark "∞") (A) 10 to 15 mm

IMPORTANT:

- Make sure that no obstacles, such as stones, are caught in the crawler. Remove such obstacles before adjusting the crawler tension.

- Crawler seam

The ends of the rubber crawler are joined with a seam. When adjusting the crawlers, the seam must be positioned on the top centre between the idler and the sprocket.

If the seam is positioned incorrectly, the crawlers will be tensioned too loosely, and a further readjustment will be necessary.

- Rotate the crawler after adjustment one to two times to check the tension.
- Additionally the following points are to be observed when adjusting rubber crawlers.
 - If the crawler slackens more than 25mm, readjust them.
 - Check crawler tension 30 hours after initial use and readjust if necessary. Check and adjust thereafter every 50 service hours.

Special Information when Using Rubber Crawlers

- When turning, preferably make a slow swing turn. Avoid spin turns to lessen lug wear and ingress of dirt.
- The relief valve may be activated if too much dirt and sand clog the crawlers. In this case move the machine for a short distance straight backwards to let the earth and sand fall off, then a turn can be made.
- Avoid using rubber crawler on riverbeds, stony underground, ferro-concrete and iron plates. The rubber can be damaged as well as crawler wear increasing.

CHANGING THE BUCKET



CAUTION

To avoid personal injury:

- When the coupling pins are removed or installed, chips may come off. Always use gloves, goggles and a helmet.
- When the change of the equipment must be performed with the engine running, always work as a 2-person team.

One person sits in the operator's seat and the other works on the machine.

- Do not use your fingers to center the holes, since they may be injured or even cut in case of sudden or uncontrolled movements.
- Read the manual of the attachment to do a correct operation safely when other attachments are installed instead of Kubota specified bucket.

FUSES

Replacing Fuses

1. Remove the cover of the fuse box.
2. Replace the burnt out fuse with a fuse having the same capacity.

Fuse Capacities and Circuits

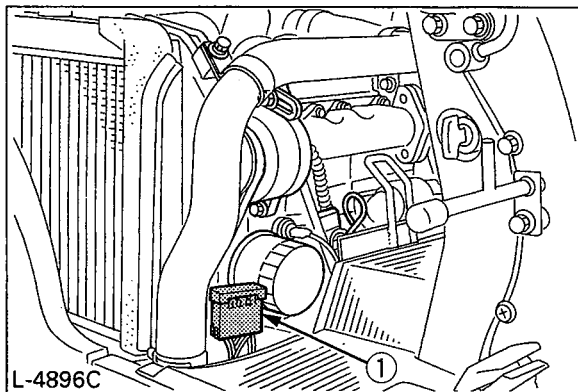

(1) Fuse box

No.	Capacity	Circuit
1	15A	Fuel cut solenoid
2	10A	Working lamp, Horn
3	5A	Hour meter, Fuel pump, Control lamps, Regulator
4	5A	Timer relay
	15A, 10A, 5A	Spare fuses

Slow Blow Fuse

Slow blow fuse is provided to protect the electrical circuits. If the fusible link is blown, check the electrical circuits for problems and then replace with a new compatible slow blow fuse.

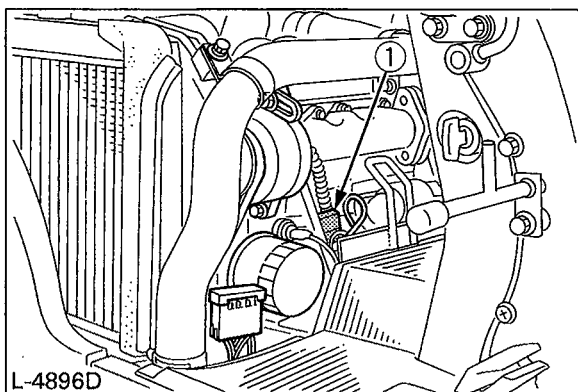

(1) Slow blow fuse

TROUBLESHOOTING

If the excavator does not give the desired performance, or when problems arise, refer to the table below and take appropriate measures.

Trouble		Cause	Countermeasure
Engine	Starting difficulties	Fuel is too viscous	* Check fuel tank and filter * Remove impurities and water * If necessary, replace filter
		Air or water in the fuel system	* Remove water from the fuel tank * Check fuel pipe joint bolts and nuts for looseness * Purging of the fuel system (for fuel filter and injection pump, see "PURGING OF THE FUEL SYSTEM" in "OTHER ADJUSTMENTS AND REPLACEMENTS".)
		Oil viscosity is too high so that the engine runs sluggishly in winter	* Pour hot water over the radiator * Use oils of different viscosities depending on the ambient temperature. (Use SAE10W, SAE10W-30 or SAE10W-40)
		Battery is almost dead; insufficient compression	* Recharge battery
	Insufficient engine power	Low fuel level	* Check fuel and add if necessary
		Clogged air cleaner	* Clean the air filter element
	Engine suddenly stops	Low fuel level	* Check fuel and add if necessary * Purge the fuel system
	Abnormal exhaust gas colour	Poor fuel	* Use high quality fuel
		Too much engine oil	* Drain engine oil to prescribed oil level
	Water temperature warning lamp ON (Temperature too high for overheating)	Worn or torn fan belt	* Adjust or replace
		Coolant level too low	* Fill to prescribed level
		Radiator grill or fins are clogged	* Clean
		Coolant is contaminated with rust from the cylinder head or crank case	* Replace coolant fluid and add anti-rust
		Defective radiator cap (Evaporation)	* Replace
		Corroded coolant pipes	* Clean
Continuous operation under full load		* Reduce load	
Engine oil level too low		* Fill to prescribed level	
Use of poor fuel	* Use prescribed fuel		

Trouble		Cause	Countermeasure
Hydraulic System	Boom, arm, bucket, drive, swing and dozer power is too low	Hydraulic oil level too low	* Add oil
		Leakages of hoses and / or joints	* Replace hose or joint
	Non-function of swing motor	Swing lock pin is in lock position	* Remove swing lock pin in unlock position
Drive System	Deviation of drive direction	Blocked through stones	* Remove
		Crawler too loose or too tight	* Adjust accordingly

OPERATION IN COLD WEATHER CONDITIONS

PREPARATION FOR OPERATION IN COLD WEATHER

1. Replace engine oil and hydraulic oil with those of viscosities suitable for cold weather.
2. In cold weather, battery power drops, and the battery fluid may freeze if the battery is not sufficiently charged. To prevent the battery fluid from freezing, be sure to keep the battery charged at least 75% or more of its capacity after operation. To ease next starting, it is recommended to keep the battery stored in closed or heated rooms. If the battery fluid level is too low, do not add after operation, but add with the engine running before the next operation.
3. Add anti-freeze to coolant in the radiator and reserve tank, if the ambient temperature is expected to drop below 32°F (0°C). Mixing ratio of water and anti-freeze depends on the expected ambient temperature. However, a 50/50 mix is recommended.

- Mixing ratio between water and anti-freeze

Ambient Temperature	°C	-5	-10	-15	-20	-25	-30	-35
	(°F)	(+23)	(+14)	(+5)	(-4)	(-13)	(-22)	(-31)
Antifreeze	%	30	30	30	35	40	45	50
Water	%	70	70	70	65	60	55	50

IMPORTANT:

- Use permanent anti-freeze or long-life coolant.
- Drain the coolant completely and clean the radiator inside then fill with the water and anti-freeze mixture.
- As the anti-freeze also acts as an anti-corrosive, it is not necessary to add an additive to the water and anti-freeze mixture.
- See "Coolant check" under "DAILY CHECKS" in "MAINTENANCE" for radiator fill volumes.

PROCEDURE AFTER WORK CARRIED OUT

Clean the excavator thoroughly after work and wipe dry. Otherwise mud and earth on the crawlers could freeze if the temperature drops below the 32°F (0°C) mark. Operation of the excavator is then not possible. Store the excavator in a dry place; if not possible, store on wooden planks or on mats. If the excavator is kept on damp or muddy ground, the crawlers could freeze overnight. Operation of the excavator is then not possible. Furthermore the reduction gear may be damaged.

Additionally, the hydraulic cylinders piston rods must be rubbed dry. Otherwise severe damage could occur if dirty water seeps through the seals.

LONG STORAGE



CAUTION

To avoid personal injury:

- Do not clean the excavator with the engine running.
- To avoid the danger of exhaust fume poisoning, do not operate the engine in a closed building without proper ventilation.
- When storing, remove the key from the starter switch to avoid unauthorized persons from operating the excavator and getting injured.

■ Should the Excavator be Stored for a Longer Period of Time, Observe Following Procedures:

1. The whole excavator should be cleaned thoroughly and in all cases stored indoors. If the excavator has to be kept outdoors, lay out wooden planks on even ground, place the excavator on the planks and cover completely.
2. Do an oil change and grease the excavator.
3. Heavily grease the visible sections of the piston rods.
4. Remove the battery and store indoors.
5. If it is expected that the temperature will sink below the 32°F (0°C) mark, add anti-freeze or drain coolant completely.

IMPORTANT :

- Wash the excavator after stopping the engine.
If you wash the excavator while running the engine, water may get into the air cleaner through the intakes causing engine problems.
Carefully, wash but do not splash water over the air cleaner.

■ Observe Following Procedures when the Machine is to be Operated after Long Storage.

1. Wipe off the grease from the hydraulic cylinder rods.
2. Turn on the engine and activate the attachments and the drive mechanisms without load in order to circulate the hydraulic oil . (If the machine is stored for longer than one month, undertake steps (1) and (2) once every month)

Periodic replacement of important component parts

To ensure safety in operation, you are strongly requested to inspect and service the machine at regular intervals. For added safety, ask your KUBOTA dealer to replace the following important component parts.

These parts are prone to degradation in material or subject to wear and tear with time. It is difficult to judge how much they have been affected at regular inspection. It is therefore necessary to replace them with new ones, whether wear is visible or not after a specified time of use.

If any of them is found worn even before the specified use, it must be repaired or replaced the same way as other parts.

If any of the hose clamps is found deformed or cracked, the hose clamp must also be replaced. For the hydraulic hoses other than the ones to be replaced periodically, inspect them for the following points. If found unusual, tighten them up, replace them.

When replacing the hydraulic hoses, change their O rings and sealings with new ones.

For replacement of the important parts, contact your KUBOTA dealer.

- At the following periodic inspections, check the fuel hoses and hydraulic hoses as well.

Inspection Interval	Check Points
Daily Checks	Oil leak at fuel and hydraulic hose connections and points
Every month	Oil leak at fuel and hydraulic hose connections and points Damages at fuel and hydraulic hose (cracks, chafing)
Every year	Oil leak at fuel and hydraulic hose connections and points Interference, deformation, degradation, twist and other damages (cracks, chafing) of fuel and hydraulic hoses

List of important component parts

No.	Component Parts	Used Place	Q'ty	Period
1	Fuel hose	Fuel tank-Fuel filter	2	Every 2 years or 4000 hours
		Fuel filter-Fuel pump	1	
		Fuel pump-Fuel filter	1	
		Fuel filter-Fuel nozzle	2	
		Fuel nozzle-Fuel tank	1	
2	Hydraulic hose (suction)	Tank-Main pump	1	
3	Hydraulic hose (delivery)	Main pump-Control valve	2	
4	Hydraulic hose (Boom cylinder)	Control valve-Boom cylinder	2	
5	Hydraulic hose (Arm cylinder)	Control valve-Arm cylinder	2	
6	Hydraulic hose (Bucket cylinder)	Control valve-Bucket cylinder	2	
7	Hydraulic hose (Swing cylinder)	Control valve-Swing cylinder	2	
8	Hydraulic hose (Dozer cylinder & Track cylinder)	Control valve-Rotary joint	4	
		Rotary joint-Dozer cylinder	4	
		Rotary joint-Tank cylinder	2	
9	Hydraulic hose (Service port)	Control valve-Joint	1	
		Joint-Return pipe	1	
10	Hydraulic hose (Swivel motor)	Control valve-Swivel motor	2	

To prevent serious damage to the hydraulic system, use only a KUBOTA genuine hydraulic hose.

RECOMMENDED OILS

IMPORTANT

1. Before delivery, the hydraulic oil used was an ISO 46 viscosity grade.
2. Use engine oil API service classification CD, CE or CF.
3. Use SAE 90 (API, CLA/GL5) as drive unit oil for all seasons.

	Application	Viscosity	Shell	Mobil	Exxon	MIL-Standard
Engine oil	In winter or low temperatures	SAE 10W	Shell Rotella T10W Shell Rimula 10W	Mobil Delvac 1310	XD-3 10W XD-3 Extra 10W	MIL-L-2104C MIL-L-2104D
		SAE 20W	Shell Rotella T20W-2 Shell Rimula 20W-20	Mobil Delvac 1320	XD-3 20W-20 XD-3 Extra 20W-20	
	In summer or high ambient temperatures	SAE 30	Shell Rotella T30 Shell Rimula 30	Mobil Delvac 1330	XD-3 30 XD-3 Extra 30	
		SAE 40	Shell Rotella T40 Shell Rimula 40	Mobil Delvac 1340	XD-3 40 XD-3 Extra 40	
	All-Season engine oil	Multi-purpose	Shell Rimula 50	Mobil Delvac 1350		
Gear oil	In winter or low temperatures	SAE 75		Mobilube HD80W-90		MIL-L-2105C
			Shell oil S8643			
	In summer or high ambient temperatures	SAE 80		Mobilube HD80W-90		MIL-L-2105
			Shell Spirax HD80W			
		SAE 90		Mobilube 46		
	All-weather gear oil	Multi-purpose	SAE 140	Shell Spirax HD90	Mobilube HD80W-90	
			Shell Spirax HD140	Mobilube HD85W-140		
Hydraulic oil	In winter or low temperatures	ISO 32	Shell Tellus T32	Mobil DTE-Oil 13	NUTO H32	
		ISO 46	Shell Tellus T46	Mobil DTE-Oil 15	NUTO H46	
	In summer or high ambient temperatures	ISO 68	Shell Tellus T68	Mobil DTE-Oil 16	NUTO H68	
Grease			Shell Alvania EP2	Mobilux EP2	BEACON Q2	
Fuel			Light oil No. 2-D (ASTM D975)			
Fuel under -23°F (-5°C)			Light oil No. 1-D (ASTM D975)			

MAIN DIMENSIONS

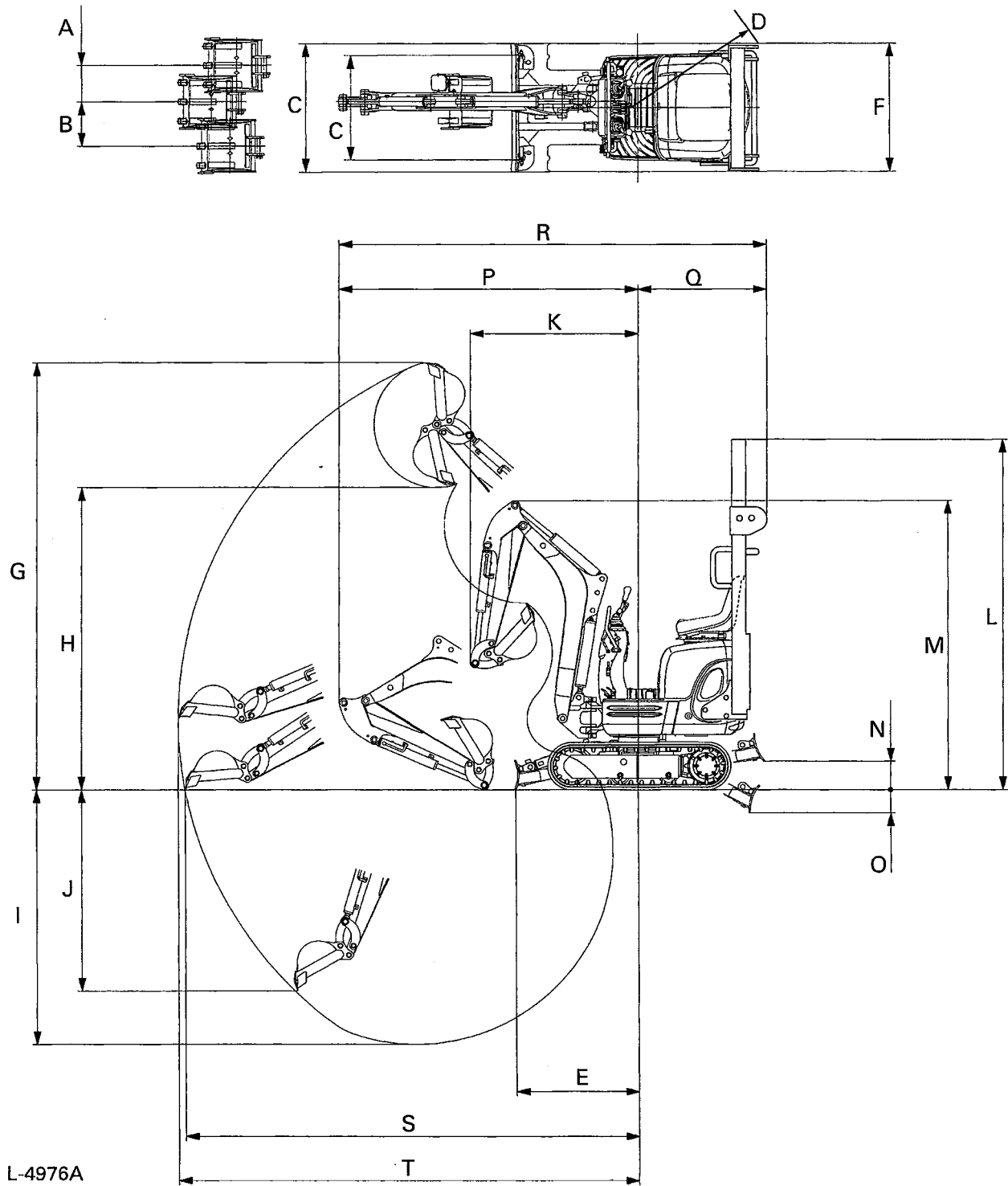

L-4976A

mm

	(A)	(B)	(C)	(D)	(E)	(F)	(G)	(H)	(I)	(J)	(K)	(L)	(M)	(N)	(O)	(P)	(Q)	(R)	(S)	(T)
K008-3	245	300	700/ 860	880	825	800	2870	2035	1715	1375	1120	2230	1945	200	180	2000	790	2790	3025	3075

LIFTING CAPACITY

1. The lifting capacities are based on ISO 10567 and do not exceed 75% of the static tilt load of the machine or 87% of the hydraulic lifting capacity of the machine.
2. The strokes are as follows.
 - 1) The load point corresponds to the front bolt part of the arm.
 - 2) The machine positions are (i) over – front (Blade up), (ii) over – front (Blade down), and (iii) over – side.
 - 3) The operating cylinder is the boom cylinder.
3. The bucket of the excavator, the hook, the sling and other lifting accessories are taken into consideration for the loads.

Machine conditions:

No bucket, all others according to standard regulations.



WARNING:

To avoid personal injury or death:

- It is forbidden to lift loads greater than those values mentioned in the lifting capacity tables.
- The values mentioned in the table are valid only on even, hard ground. When lifting on soft ground, the machine 'can tilt over due to the fact that the load is concentrated only on one side of the machine.
- The table values are calculated at the end of the arm without the bucket. In order to find the allowable loads for machines with bucket, the bucket weight must be subtracted from the values in the table.

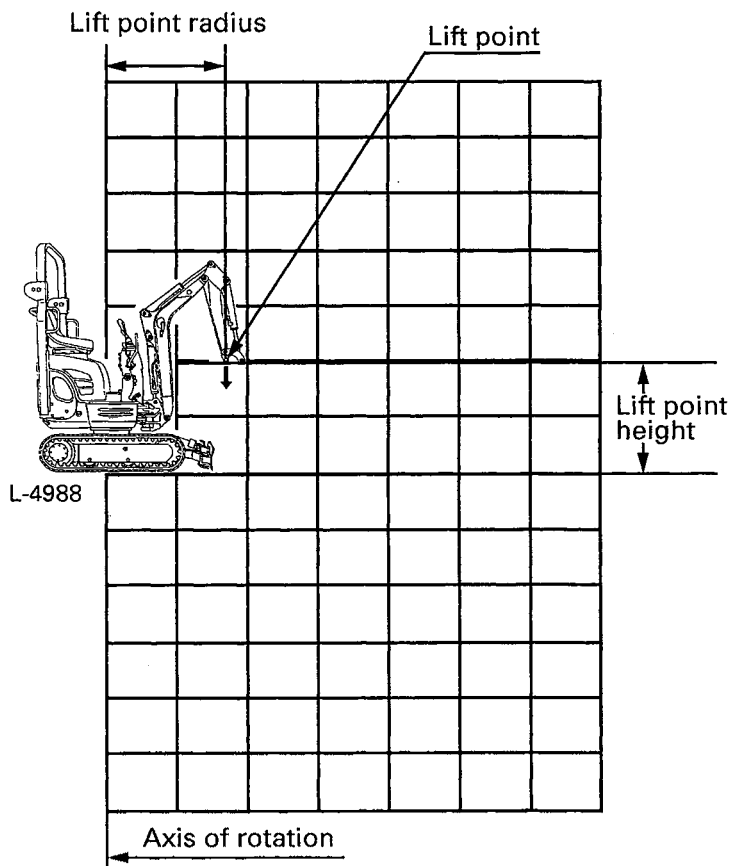

LIFTING CAPACITY

MODEL	K008-3	SPEC	RUBBER
-------	--------	------	--------

(i) OVER FRONT (BLADE UP) KN (ton)

HEIGHT (mm)	LOAD RADIUS (mm)						
	0	500	1000	1500	2000	2500	3000
GL	2500						
	2000				1.5 (0.15)		
	1500				1.5 (0.15)		
	1000			2.3 (0.24)	1.5 (0.15)	1.0 (0.10)	
	500			2.1 (0.22)	1.4 (0.14)	1.0 (0.10)	
	0		3.8 (0.39)	2.0 (0.20)	1.3 (0.14)	1.0 (0.10)	
	-500		3.8 (0.39)	1.9 (0.20)	1.3 (0.13)		
	-1000		3.6 (0.37)	2.0 (0.20)	1.3 (0.13)		
	-1500						

(iii) OVER SIDE (TRACK WIDTH 860 mm) KN (ton)

HEIGHT (mm)	LOAD RADIUS (mm)						
	0	500	1000	1500	2000	2500	3000
GL	2500						
	2000				1.2 (0.13)		
	1500				1.2 (0.13)		
	1000			1.9 (0.19)	1.2 (0.12)	0.8 (0.09)	
	500			1.7 (0.17)	1.1 (0.12)	0.8 (0.08)	
	0		2.9 (0.29)	1.6 (0.16)	1.1 (0.11)	0.8 (0.08)	
	-500		2.9 (0.29)	1.5 (0.16)	1.0 (0.11)		
	-1000		2.9 (0.30)	1.5 (0.16)	1.0 (0.11)		
	-1500						

(ii) OVER FRONT (BLADE DOWN) KN (ton)

HEIGHT (mm)	LOAD RADIUS (mm)						
	0	500	1000	1500	2000	2500	3000
GL	2500						
	2000				1.9 (0.20)		
	1500				1.8 (0.18)		
	1000			2.4 (0.24)	2.0 (0.21)	1.7 (0.17)	
	500			3.4 (0.34)	2.3 (0.23)	1.7 (0.17)	
	0		6.0 (0.61)	3.4 (0.35)	2.2 (0.23)	1.5 (0.16)	
	-500		4.9 (0.50)	2.9 (0.30)	1.9 (0.20)		
	-1000		3.6 (0.37)	2.1 (0.22)	1.3 (0.13)		
	-1500						



KUBOTA TRACTOR CORPORATION

CORPORATE OFFICE: 3401 DEL AMO BOULEVARD, TORRANCE, CA 90503

WESTERN DIVISION: 1175 S. Guild Ave., Lodi, CA 95240 • (209) 334-9910

CENTRAL DIVISION: 14855 F.A.A. Blvd., Fort Worth, TX 76155 • (817) 871-0900

NORTHERN DIVISION: One Kubota Way, Groveport, OH 43125 • (614) 835-1100

SOUTHEAST DIVISION: 1025 Northbrook Parkway, Suwanee, GA 30024 • (770) 995-8855

Copyright (c) 2010 by Kubota Tractor Corporation - All Rights Reserved

This manual may not be copied in whole or in part without the written consent of Kubota Tractor Corporation



REPRINTED IN U.S.A.
September 2010
Code No. RA028-82217

