

White-Rodgers™

Single-Stage Thermostat

with **5-1-1 DAY** scheduling

Install Guide

Want to install the easy way?

EASY DIY **WIZARD** INSTALL

Go to **thermostatwizard.com**

GUIDE CONTENTS

Preparations	3
Thermostat details	4
Removal of your old thermostat.....	5
Mounting and wiring your new thermostat..	10
Checking thermostat operation.....	12
Programming your thermostat.....	16
Specifications	33
Troubleshooting	35



WARNING

Failure to follow and read all instructions carefully before installing or operating this control could cause personal injury and/or property damage.

1. PREPARATIONS

1.1 Check package contents

This package should contain the following items:

- Thermostat
- Mounting screws and wall anchors (x2)
- 2 AAA batteries
- Terminal wire label stickers
- Installation instructions

1.2 Gather tools

Required tools:

- Flat-head Screwdriver
- Small pliers (needle-nose)
- Drill with 3/16" (4 mm) bit

Optional tools:

- Wire cutters/stripper
- Hammer

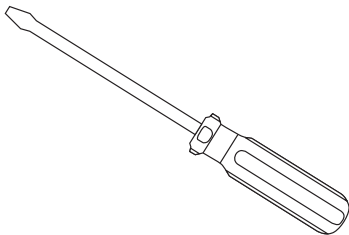

2. THERMOSTAT DETAILS

The thermostat buttons and switches

- ① Raises temperature setting.
- ② Lowers temperature setting.
- ③ TIME button.
- ④ PRGM (program) button.
- ⑤ RUN (run program) button.
- ⑥ HOLD temperature button.
- ⑦ FAN switch (ON, AUTO).
- ⑧ SYSTEM switch (COOL, OFF, HEAT).

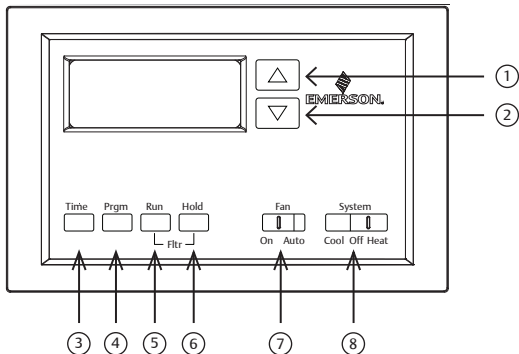

3. REMOVING OLD THERMOSTAT

3.1 Turn off power

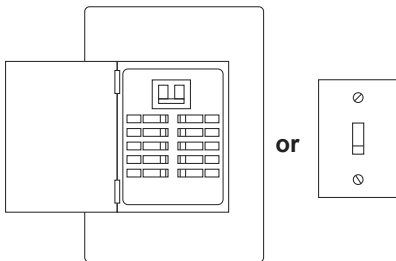

WARNING

To prevent electrical shock and/or equipment damage, disconnect electrical power to the system at the main fuse or circuit breaker box, or by flipping a switch at the air handler. Do not restore power until installation is complete.

To ensure the power to your heating and cooling system has been turned off, try to turn on heating or cooling by changing the temperature on your old thermostat.

3.2 Remove the old thermostat cover

Remove the old thermostat's front cover from the wall base. Some covers pull off easily, while others may need to be removed by prying the cover off with a screwdriver.

CAUTION

Your old thermostat may have a sealed glass tube containing mercury. Be careful not to damage the tube or dispose of the tube in your trash. For safe disposal information, please see Mercury Notice on page 43.

3.3 Label wires

Tip: Taking a picture with a camera or smartphone can help you not only remember how wires are connected to the terminals, but can also ensure that you label your wires correctly.

Using your screwdriver, carefully unscrew one wire at a time from the terminal block and attach the corresponding wire label sticker.

Please note that not all terminals may be used, and that there's no standard color code for thermostat wires, so your wire colors may vary. For your reference, we've included a terminal label reference chart on page 7 to help you connect the wires in your old thermostat to your new thermostat in case you get stuck.

Terminal labeling reference chart

If your current terminal has the following letter	Label the wires with the following letters	Terminal function
RH, R, R5, 5	RH	24V Power (Heating)
RC	RC	24V Power (Cooling)
W, W1, 4	W	Heating Relay
Y, Y1	Y	Cooling Relay
G	G	Fan Relay
O	O	Reversing Valve (for heat pump applications energized in Cool mode)
B	B	Reversing Valve (for heat pump applications energized in Heat mode)

3.4 Identify jumper wire

On your old thermostat, if...	Then, on your new thermostat...
Terminal RC and RH are connected with a jumper wire	Leave the jumper wire in its place
There's only one R wire (RC, RH, R or R5) coming out of the wall	Leave the jumper wire in its place
Terminal RC and RH (or 5 or R5) are NOT connected by a jumper wire	Remove the jumper wire between RC and RH

For terminal Y and W:

If you have a heat pump with reversing valve, connect Y and W with a jumper wire on your new thermostat.

If you need help with labeling and wiring, please contact Customer Support at 877.654.9394 or email wr.techsupport@emerson.com — we're here to help!

3.5 Remove old thermostat base

With all of your wires disconnected and properly labeled, you may now safely remove the thermostat base from your wall.

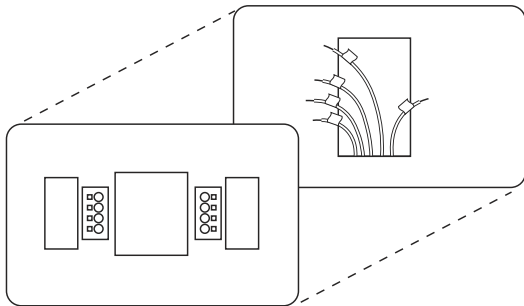

Tip: Worried about having your wires falling into your wall? Keep the wires secure by wrapping the them around a pencil.

4. MOUNTING AND WIRING YOUR NEW THERMOSTAT

4.1 Install new thermostat base

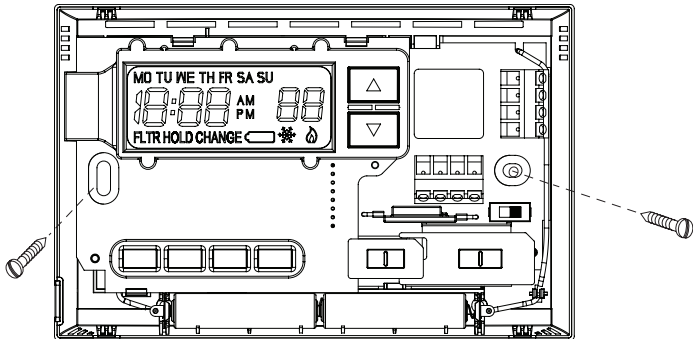

Mount your new thermostat base using the supplied screws. Drill holes and insert wall anchors to secure the thermostat base to the wall, if necessary.

4.2 Connect wires to corresponding terminal blocks

Match each labeled wire to its corresponding terminal on the mounted thermostat base. Insert each labeled wire into the hole of its matching terminal, and using the screwdriver, tighten the screw on the terminal block securely.

CAUTION

Take care when securing and routing wires so they do not short to adjacent terminals or rear of thermostat. Personal injury and/or property damage may occur.

4.3 Set switch and advanced wiring

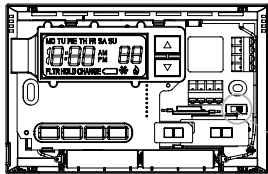

Electric / Gas
switch

If you have either a gas or oil furnace, set the switch to GAS.

If you have an electric furnace, set the switch to ELEC.

4.4 Install the batteries and attach front cover

Install the included AAA alkaline batteries and push the front cover on to the thermostat base until it's secure.

4.5 Turn on power

Turn on your power at the source.

Congratulations! You've completed the thermostat installation process

5. CHECK THERMOSTAT OPERATION



Tip: If at any time during testing your system does not operate properly, please contact Customer Support at 877.654.9394 or email wr.techsupport@emerson.com

5.1 Fan operation

If your system **does not** have a **G** terminal connection, skip to **5.2 Heating system**.

1. Move FAN switch to **ON** position. The blower should begin to operate.
2. Move FAN switch to **AUTO** position. The blower should stop immediately.



5.2 Heating system

1. Move SYSTEM switch to **HEAT** position. If the heating system has a standing pilot, be sure to light it.
2. Press  to adjust thermostat setting room temperature. The heating system should begin to operate.
3. Press  to adjust temperature setting below room temperature. The heating system should stop operating.

5.3 Cooling system

CAUTION

To prevent compressor and/or property damage, if the outdoor temperature is below 50°, DO NOT operate the cooling system

1. Move SYSTEM switch to **COOL** position.
2. Press  to adjust thermostat setting below room temperature. The blower should come on immediately on high speed, followed by bold air circulation.
3. Press  to adjust temperature setting above room temperature. The cooling system should stop operating.

5.4 Typical wiring diagrams

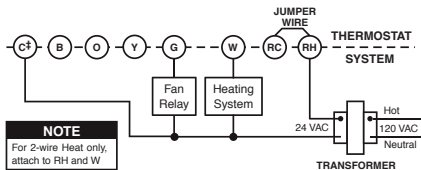

Typical wiring diagram for heat only,
3-wire, single transformer systems

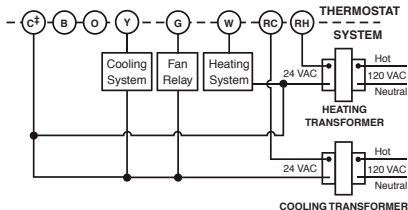

Typical wiring diagram for heat/cool,
5-wire, two-transformer systems

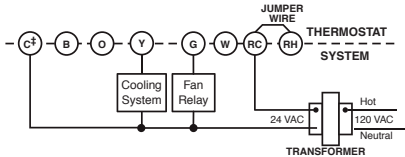

Typical wiring diagram for cool only,
3-wire, single transformer systems

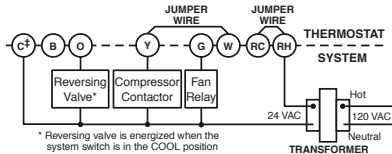

Typical wiring diagram for heat pump
with reversing valve energized in COOL

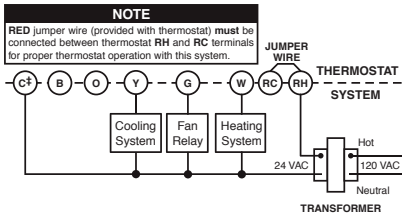

Typical wiring diagram for heat/cool,
4-wire, single transformer systems

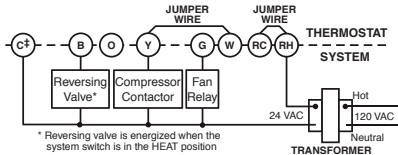

Typical wiring diagram for heat pump
with reversing valve energized in HEAT

‡ c-wire not required

6. PROGRAMMING YOUR THERMOSTAT

Before you begin programming your thermostat, you should be familiar with its features and with the display and the location and operation of the thermostat buttons. Your thermostat consists of two parts: the thermostat cover and the base. To remove the cover, pull it straight out from the base. To replace the cover, line up the cover with the base and press until the cover snaps onto the base.

6.1 The thermostat buttons and switches

- ① Raises temperature setting.
- ② Lowers temperature setting.
- ③ TIME button.
- ④ PRGM (program) button.
- ⑤ RUN (run program) button.
- ⑥ HOLD temperature button.
- ⑦ FAN switch (ON, AUTO).
- ⑧ SYSTEM switch (COOL, OFF, HEAT).

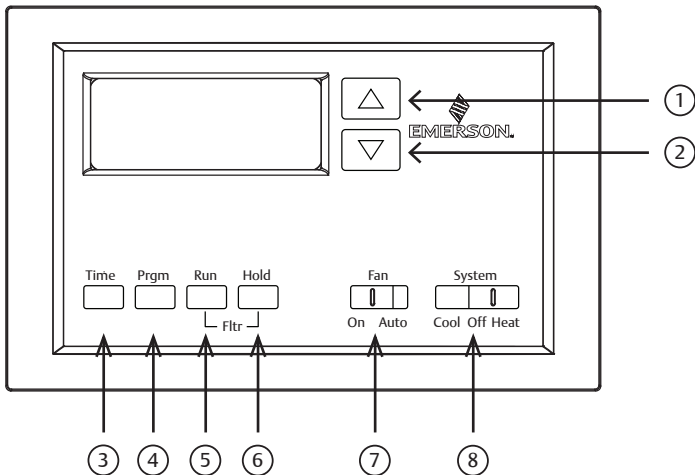

6.2 The display

- ⑨ Indicates day of the week.
- ⑩ **Flame icon** (🔥) is displayed when the SYSTEM switch is in the HEAT position. **Snowflake icon** (❄️) is displayed (non-flashing) when the SYSTEM switch is in the COOL position. **Snowflake** is displayed (flashing) if the thermostat is in lockout mode to prevent the compressor from cycling too quickly.
- ⑪ Displays “**CHANGE** ⏪” when the 2 "AAA" batteries are low and should be replaced. Only “**CHANGE** ⏪” and “**LO**” in the minutes field are displayed when batteries are low with no system power.
- ⑫ Alternately displays current time and temperature. Displays “**LO**” in the minutes field when batteries are low.
- ⑬ The word “**HOLD**” is displayed when the thermostat is in the HOLD mode. “**HOLD**” is displayed flashing when the thermostat is in a temporary HOLD Mode.
- ⑭ Displays currently programmed set temperature (this is blank when SYSTEM switch is in the **OFF** position).
- ⑮ Displays “**FLTR**” when the system has run for the programmed filter time period as a reminder to change or clean your air filter.

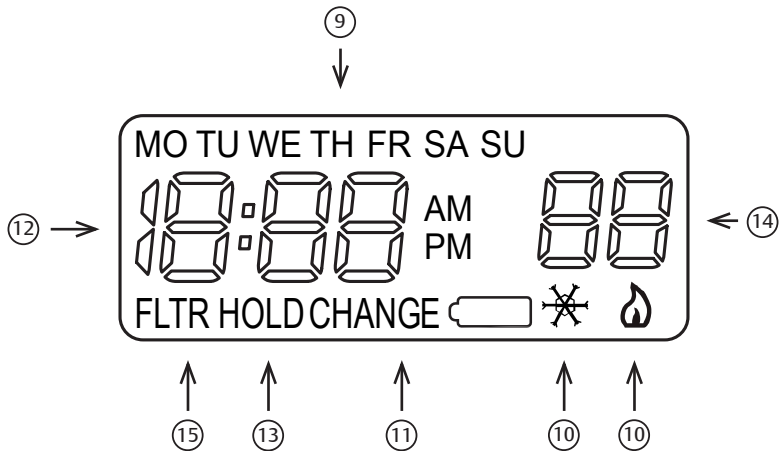

6.3 Configuration menu

The configuration menu allows you to set certain thermostat operating characteristics to your system or personal requirements.

Press RUN to make sure the thermostat is in the run program mode, then press PRGM and RUN at the same time to enter the configuration menu. The display will show the first item in the configuration menu.



The configuration menu table summarizes the configuration options. An explanation of each option follows.

Press HOLD to change to the next menu item or press TIME to go backwards to the previous item in the menu. To exit the menu and return to the program operation, press RUN. If no keys are pressed within fifteen minutes, the thermostat will revert to normal operation.

1. **Select Temporary Hold Time** – The thermostat can hold any temperature you set it to for the amount of time you select on this option. Your choices are 0:00 to 8:00 hours in 15 minute increments. 0:00 disables the function

Example:

1. You have selected 3:00 hours for the Temporary Hold time period.
2. With the thermostat set to Heat or Cool, press HOLD **for approximately five seconds** until HOLD time (3:00 indicating 3 hours) appears as a setting reminder.



3. After releasing the button, “**HOLD**” on the display will blink.
4. Use  or  to set the temperature to your preference. The thermostat will maintain this temperature setting for 3 hours with “**HOLD**” blinking to remind you it is in Temporary Hold. After 3 hours the thermostat will go back to the program temperature and “**HOLD**” will no longer blink or display.
2. **Select FA or SL (Fast or Slow) Heating Cycle Rate** – The FA setting is frequently used for gas, oil or electric heat. The SL setting produces a longer heating cycle which is normally for hot water or steam (hydronic) systems. Both settings produce very accurate temperature control and can be set to your personal preference. FA cycles the system just under 1°F and the SL setting cycles at approximately 1.5°F.
3. **Select backlit display** – The display backlight improves display contrast in low lighting conditions. Selecting backlight **ON** will keep the light on for a short period of time after any key is pressed. Selecting **OFF** will keep the light off.
4. **Select Energy Management Recovery OFF or ON** – Energy Management Recovery (EMR) causes the thermostat to start heating or cooling early to make the building temperature reach the program setpoint at the time you specify. Heating will start 5 minutes early for every 1° of temperature required to reach setpoint.

Example:

You select EMR and have your heating programmed to 65° at night and 70° at 7 AM. If the building temperature is 65° the difference between 65° and 70° is 5°. Allowing 5 minutes per degree the thermostat setpoint will change to 70° at 6:35 AM. Cooling allows more time per degree because it takes longer to reach temperature.

- 5. Select filter replacement run time** – The thermostat will display “FLTR” after a set time of operation. This is a reminder to change or clean your air filter. This time can be set from 0 to 1950 hours in 50 hour increments. **A selection of 000 will cancel this feature.** When “FLTR” is displayed, you can clear it by pressing HOLD and RUN at the same time. This resets the timer and starts counting the hours until the next filter change. Changing the time in the menu also resets the timer.
- 6. Select Compressor Lockout LOC OFF or ON** – Selecting LOC ON will cause the thermostat to wait 5 minutes before turning on the compressor if the heating and cooling system loses power. It will also wait a minimum of 5 minutes between cooling cycles. This is intended to help protect the compressor from short cycling. Some newer compressors already have a time delay built in and do not require this feature. Your compressor manufacturer can tell you if the feature is already present in their system. When the compressor time delay occurs it will flash the (snowflake icon) for about five minutes then turn on the compressor.
- 7. Select Temperature Display Adjustment 4 LO to 4 HI** – Allows you to adjust the room temperature display +/- 4°. Your thermostat was accurately calibrated at the factory but you have the option to change the display temperature to match your previous thermostat.
- 8. Select F° or C° Readout** – Changes the display readout to Celsius or Fahrenheit as required.





Configuration Menu

Step	Press Button(s)	Displayed (Factory Default)	Press  or  to select:	COMMENTS
1	PRGM and RUN	HOLD (0:00)	0 to 8 hrs (in 15 minute increments)	Select temporary Hold time
2	HOLD*	ϕ (FA)	SL	Select FA or SL (Fast or Slow) heating cycle rate
3	HOLD*	d-L (ON)	OFF	Select display backlight OFF or ON
4	HOLD*	E (ON)	OFF	Select Energy Management Recovery OFF or ON
5	HOLD*	Filter (000)	0 to 1950 hours (in 50 hour increments)	Select filter replacement run time
6	HOLD*	LOC (OFF)	ON	Select compressor lockout OFF or ON
7	HOLD*	0 HI (0)	4 LO to 4 HI	Select temperature display adjustment higher or lower
8	HOLD*	(F)	C	Select temperature display to F or C
9	RUN			Returns to normal operation

* Press HOLD to advance to next item or TIME to move backwards to previous item

6.4 Operating features

This section contains information about the many features of your new thermostat.

- **SIMULTANEOUS HEATING/COOLING PROGRAM STORAGE** — When programming, you can enter both your heating and cooling programs at the same time. There is no need to reprogram the thermostat at the beginning of each season.
- **TEMPERATURE OVERRIDE** — Press  or  until the display shows your desired temperature. The thermostat will override current programming and keep the room temperature at the selected temperature until the next program period begins; then, the thermostat will automatically revert to the program.
- **HOLD TEMPERATURE** — The thermostat can hold any temperature within its range for an indefinite period without reverting to the programmed temperature. To engage this feature, press HOLD button. “HOLD” will be displayed. Then choose the desired temperature by pressing  or . The thermostat will hold the room temperature at the selected setting until you press RUN button to start program operation again.
- **CONFIGURATION MENU** — Allows you to customize certain thermostat options.

6.5 Programming your thermostat

This section will help you plan your thermostat's program to meet your needs. For maximum comfort and efficiency, keep the following guidelines in mind when planning your program:

- When heating (cooling) your building, program the temperatures to be cooler (warmer) when the building is vacant or during periods of low activity.
- During early morning hours, the need for cooling is usually minimal.

Planning your program

Look at the factory pre-programmed times and temperatures shown in the sample schedule. If this program will suit your needs, simply press the RUN button to begin running the factory preset program.

If you want to change the pre-programmed times and temperatures, follow these steps.

Determine the time periods and temperatures for your weekday and weekend programs. You must program four periods for both the weekday and weekend program. However, you may use the same heating and cooling temperatures for consecutive time periods. You can choose start times, heating temperatures, and cooling temperatures independently for both weekday and weekend programs (for example, you may select 5:00 AM and 70° as the weekday **1st period heating** start time and temperature, and also choose 7:00 AM and 76° as the weekday **1st period cooling** start time and temperature).

SAMPLE
Heating/Cooling Schedule Plan (Factory Program)

Period		WEEKDAY (5 DAY)		SATURDAY (1 DAY)		SUNDAY (1 DAY)	
		Start Time	Temperature	Start Time	Temperature	Start Time	Temperature
HEAT	1ST	6:00 AM	70°F	6:00 AM	70°F	6:00 AM	70°F
	2ND	8:00 AM	62°F	8:00 AM	62°F	8:00 AM	62°F
	3RD	5:00 PM	70°F	5:00 PM	70°F	5:00 PM	70°F
	4TH	10:00 PM	62°F	10:00 PM	62°F	10:00 PM	62°F
COOL	1ST	6:00 AM	78°F	6:00 AM	78°F	6:00 AM	78°F
	2ND	8:00 AM	85°F	8:00 AM	85°F	8:00 AM	85°F
	3RD	5:00 PM	78°F	5:00 PM	78°F	5:00 PM	78°F
	4TH	10:00 PM	82°F	10:00 PM	82°F	10:00 PM	82°F

Use the following table to plan your program time periods and the temperatures you want during each period. Fill in the complete table to have a record of your programs.

Heating/Cooling Schedule Plan

Period		WEEKDAY (5 DAY)		SATURDAY (1 DAY)		SUNDAY (1 DAY)	
		Start Time	Temperature	Start Time	Temperature	Start Time	Temperature
HEAT	1ST						
	2ND						
	3RD						
	4TH						
COOL	1ST						
	2ND						
	3RD						
	4TH						



Entering your program

Follow these steps to enter the heating and cooling programs you have selected.



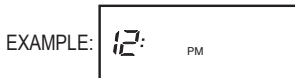

Set Current Time and Day

1. Press TIME button once. The display will show the hour only.



2. Press and hold either  or  until you reach the correct hour and AM/PM designation (**AM** begins at midnight; **PM** begins at noon).
3. Press TIME once. The display window will show the minutes only.





4. Press and hold either  or  until you reach the correct minutes.
5. Press TIME once. The display will show the day of the week.
6. Press  or  until you reach the current day of the week.
7. Press RUN once. The display will show the correct time and room temperature alternately.

Set Heating Program

1. Move the SYSTEM switch to **HEAT**.
2. Press PRGM once. **“MO TU W TH FR”** (indicating weekday program) will appear in the display. Also displayed are the currently programmed start time for the 1st heating period and the currently programmed temperature (flashing).



This display window shows that for the 1st weekday period, the start time is 6:00 AM, and 68° is the programmed temperature (this example reflects factory preprogramming).

3. Press  or  to change the displayed temperature to your selected temperature for the 1st heating program period.
4. Press TIME once (the programmed time will flash). Press  or  until your desired time appears. The time will change in 15 minute increments. When your selected time is displayed, press TIME again to return to the change temperature mode.
5. Press PRGM once. The currently programmed start time and setpoint temperature for the **2nd heating** program period will appear.
6. Repeat steps 3 and 4 to select the start time and heating temperature for the 2nd heating program period.
7. Repeat steps 3 through 5 for the 3rd and 4th heating program periods. Weekday heating programs are now complete.
8. Press PRGM once. "**SA**" (indicating Saturday program) will appear in the display, along with the start time for the 1st heating period and the currently programmed temperature.
9. Repeat steps 3 through 7 to complete Saturday heating programming.
10. Press PRGM once. "**SU**" (indicating Sunday program) will appear in the display, along with the start time for the 1st heating period and the currently programmed temperature.
11. Repeat steps 3 through 7 to complete Sunday heating programming.

12. When you have completed entering your heating program, press RUN.

Set Cooling Program

CAUTION

If the outside temperature is below 50° F, disconnect power to the cooling system before programming. Energizing the air conditioner compressor during cold weather may cause personal injury or property damage.

1. Move SYSTEM switch to **COOL** position.
2. To set your cooling program, follow the same procedure as setting your heating program, but use your selected cooling times and temperatures.

Check your programming

Follow these steps to check your thermostat programming one final time before beginning thermostat operation.

1. Move SYSTEM switch to **HEAT** position.
2. Press PRGM to view the 1st weekday heating period time and temperature. Each time you press PRGM, the next heating period time and temperature will be displayed in sequence for weekday, then weekend program periods (you may change any time or temperature during this procedure).
3. Press RUN.
4. Move SYSTEM switch to **COOL** position.
5. Repeat step 2 to check cooling program.
6. Move SYSTEM switch to **HEAT** or **COOL** and press RUN to begin program operation.

CONGRATULATIONS! Your new thermostat is now programmed.

7. SPECIFICATIONS

ELECTRICAL DATA

Electrical Rating:

8 to 30 VAC 50/60 Hz. or D.C.

0.05 to 1.0 Amps (Load per terminal)

1.5 Amps Maximum Total Load (All terminals combined)

THERMAL DATA

Setpoint Temperature Range: 45°F to 90°F (7°C to 32°C)

Operating Ambient Temperature Range: 32°F to 105°F

Operating Humidity Range: 0 to 90% RH (non-condensing)

Shipping Temperature Range: -4°F to 149°F

APPLICATIONS

For use with:



- Standard heat/cool or heat only systems
- Electric heat systems
- Gas or oil fired systems
- Gas systems with intermittent ignition devices (I.I.D.) and/or vent dampers
- Hydronic (hot water or steam) systems
- Single-stage heat pump systems (no auxiliary heat)
- Millivolt

DO NOT USE WITH:

- Multi-stage systems
- Systems exceeding 30 VAC and 1.5 amps
- 3-wire zoned hydronic heating systems

8. TROUBLESHOOTING

Reset Operation

If a voltage spike or static discharge blanks out the display or causes erratic thermostat operation you can reset the thermostat by pressing , ,  and TIME at the same time. This also resets the factory defaults to the configuration menu and program. If the thermostat has power, has been reset and still does not function correctly contact your heating/cooling service person or place of purchase.

Batteries

For optimum performance, we recommend replacing batteries once a year with fresh "AAA" alkaline batteries.

Symptom	Possible Cause	Corrective Action
No Heat/No Cool/No Fan (common problems)	<ol style="list-style-type: none"> 1. Blown fuse or tripped circuit breaker. 2. Furnace power switch to OFF. 3. Furnace blower compartment door or panel loose or not properly installed. 	<p>Replace fuse or reset breaker.</p> <p>Turn switch to ON.</p> <p>Replace door panel in proper position to engage safety interlock or door switch.</p>
No Cool	<ol style="list-style-type: none"> 1. SYSTEM Switch not set to Cool. 2. Loose connection to thermostat or system. 3. Cooling system requires service or thermostat requires replacement. 	<p>Set SYSTEM Switch to COOL and lower setpoint temperature below room temperature.</p> <p>Verify thermostat and system wires are securely attached.</p> <p>Same procedure as diagnostic for No Heat condition except set the thermostat to COOL and lower the setpoint below the room temperature. There may be up to a five minute delay before the thermostat clicks in Cooling.</p>

Symptom	Possible Cause	Corrective Action
No Heat	<ol style="list-style-type: none"> 1. Pilot light not lit. 2. SYSTEM Switch not set to HEAT. 3. Loose connection to thermostat or system. 4. Furnace Lock-Out Condition. Heat may also be intermittent. 5. Heating system requires service or thermostat requires replacement.. 	<p>Re-light pilot.</p> <p>Set SYSTEM Switch to HEAT and raise setpoint temperature above room temperature.</p> <p>Verify thermostat and system wires are securely attached.</p> <p>Many furnaces have safety devices that shutdown when a lock-out condition occurs. If the heat works intermittently contact the furnace manufacturer or local service person for assistance.</p> <p>Diagnostic: Set SYSTEM Switch to HEAT and raise the setpoint above room temperature. Within a few seconds the thermostat should make a soft click sound. This sound usually indicates the thermostat is operating properly. If the thermostat does not click, try the reset operation listed below. If the thermostat does not click after being reset contact your heating and cooling service person or place of purchase for a replacement. If the thermostat clicks, contact the furnace manufacturer or a service person to verify the heating is operating correctly.</p>

Symptom	Possible Cause	Corrective Action
Heat, Cool or Fan Runs Constantly.	<ol style="list-style-type: none"> 1. FAN Switch set to Fan ON. 2. Possible short in wiring. 3. Possible short in thermostat. 4. Possible short in Heat/Cool/Fan system. 	<p>Check each wire connection to verify they are not shorted or touching together. No bare wire should stick out from under terminal screws. Try resetting the thermostat. If the condition persists the manufacturer of your system or service person can instruct you on how to test the Heat/Cool system for correct operation. If the system operates correctly, replace the thermostat.</p>
<p>Furnace Cycles Too Fast or Too Slow</p> <p>(narrow or wide temperature swing)</p>	<ol style="list-style-type: none"> 1. The location of the thermostat and/or the size of the Heating System may be influencing the cycle rate. 	<p>Item 2 in the Configuration Menu is the adjustment that controls the cycle rate. If an acceptable cycle rate is not achieved using the FA (Fast) or SL (Slow) adjustment contact a local service person for additional suggestions.</p>

Symptom	Possible Cause	Corrective Action
Cooling Cycles Too Fast or Too Slow (narrow or wide temperature swing)	1. The location of the thermostat and/or the size of the Cooling System may be influencing the cycle rate.	The cycle rate for cooling is fixed and can not be adjusted. Contact a local service person for suggestions.
Thermostat Setting and Thermometer Disagree	1. Thermostat thermometer setting requires adjustment.	The thermometer can be adjusted +/- 4 degrees as listed in item 7 of the Configuration Menu. No other adjustment is possible.
Clock Loses or Gains Time	1. Loss of power to thermostat and low batteries.	The thermostat will maintain its program in memory even with no power/no batteries but the clock time will be incorrect when power is restored. See No Heat/No Cool/No Fan (common problems) above for items to check in the system.
Heat or Cool Starts Early	1. EMR activated	See Configuration Menu (Item 4).

Symptom	Possible Cause	Corrective Action
Thermostat Does Not Follow Program	<ol style="list-style-type: none"> 1. AM or PM set incorrectly in program. 2. AM or PM set incorrectly on the clock. 3. Voltage spike or static discharge. 	Check current clock and program settings including the AM or PM designations for each time period. If a voltage spike or static discharge occurs use the Reset Operation listed above.
Blank Display and/or Keypad Not Responding	<ol style="list-style-type: none"> 1. Loss of power and dead batteries. 2. Voltage Spike or Static Discharge. 	Replace batteries and check heat/cool system for proper operation. If a voltage spike or static discharge occurs use the Reset Operation listed above.

CONTACT US

Customer support: 877.654.9394 or wr.techsupport@emerson.com

MERCURY NOTICE

This product does not contain mercury. However, this product may replace a product that contains mercury.

Mercury and products containing mercury must not be discarded in household trash.

Refer to thermostat-recycle.org for location to send product containing mercury.

FOR CALIFORNIA RESIDENTS

Warning: This product contains a chemical known to the state of California to cause cancer and birth defects and other reproductive harm.

