

BrassCraft®

Cable Drum Machine
Operation
Manual
BC260 SERIES
Cleans 1 1/4" to 3" lines up to 50'

Used For: Sink, Shower & Floor Drains



" WARNING - Read All Instructions, When Using Electric Tools, Basic Safety Precautions Should Always Be Followed To Reduce The Risk Of Fire, Electric Shock And Personal Injury. Save These Instructions."

651-950200

GENERAL SAFETY

Important

Replacement parts:
When servicing, use only identical replacement parts.

Polarized plugs:

To reduce risk of electric shock, this equipment has a polarized plug (one blade is wider than the other). This plug will fit in a polarized outlet one way. If the plug does not fit fully in the outlet, reverse the plug. If it still does not fit, contact a qualified electrician to install the proper outlet.

Do not change the plug in any way.

WORK AREA

- Keep your work area clean and well lit. Cluttered benches and dark areas invite accidents.
- Do not operate power tools in explosive atmospheres, such as in the presence of flammable liquids, gases, or dust. Power tools create sparks which may ignite the dust or fumes.
- Keep bystanders, children, and visitors away while operating a power tool. Distractions can cause you to lose control.

ELECTRIC SAFETY

- Grounded tools must be plugged into an outlet properly installed and grounded in accordance with all codes and ordinances. Never remove the grounding prong or modify the plug in any way. Do not use any adapter plugs. Check with a qualified electrician if you are in doubt as to whether the outlet is properly grounded. If the tools should electrically malfunction or break down, grounding provides a low resistance path to carry electricity away from the user.
- Double Insulated tools are equipped with a polarized plug (one blade is wider than the other.) This plug will fit in a polarized outlet only one way. If the plug does not fit fully in the outlet, reverse the plug. If it still does not fit, contact a qualified electrician to install a polarized outlet. Do not change the plug in any way. Double Insulation eliminates the need for a three wire grounded power cord and grounded power supply system. (Applicable only to Class II tools.)
- Avoid body contact with grounded surfaces such as pipes, radiators, ranges and refrigerators. There is an increased risk of electric shock if your body is grounded.
- Don't expose power tools to rain or wet conditions. Water entering a power tool will increase the risk of electric shock.
- Do not abuse the cord. Never use the cord to carry the tools or pull the plug from an outlet. Keep cord away from heat, oil, sharp edges or moving parts. Replace damaged cords immediately. Damaged cords increase the risk of electric shock.
- When operating a power tool outside, use an outdoor extension cord marked "W-A" or "W." These cords are rated for outdoor use and reduce the risk of electric shock.

PERSONAL SAFETY

- Stay alert, watch what you are doing and use common sense when operating a power tool. Do not use tool while tired or under the influence of drugs, alcohol, or medication. A moment of inattention while operating power tools may result in serious personal injury.
- Dress properly. Do not wear loose clothing or jewelry. Contain long hair. Keep your hair, clothing, and gloves away from moving parts. Loose clothes, jewelry, or long hair can be caught in moving parts.
- Avoid accidental starting. Be sure switch is off before plugging in. Carrying tools with your finger on the switch or plugging in tools that have the switch on invites accidents.
- Remove adjusting keys or wrenches before turning the tool on. A wrench or a key that is left attached to a rotating part of the tool may result in personal injury.

WARNING:
PRECAUCIÓN:



PERSONAL SAFETY CONT.

- Do not overreach. Keep proper footing and balance at all times. Proper footing and balance enables better control of the tool in unexpected situations.
- Use safety equipment. Always wear eye protection. Dust mask, non-skid safety shoes, hard hat, or hearing protection must be used for appropriate conditions.

TOOL USE AND CARE

- Use clamps or other practical way to secure and support the work piece to a stable platform. Holding the work by hand or against your body is unstable and may lead to loss of control.
- Do not force tool. Use the correct tool for your application. The correct tool will do the job better and safer at the rate for which it is designed.
- Do not use tool if switch does not turn it on or off. Any tool that can not be controlled with the switch is dangerous and must be repaired.
- Disconnect the plug from the power source before making any adjustments, changing accessories, or storing the tool. Such preventive safety measures reduce the risk of starting the tool accidentally.
- Store idle tools out of reach of children and other untrained persons. Tools are dangerous in the hands of untrained users.
- Maintain tools with care. Keep cutting tools sharp and clean. Properly maintained tools, with sharp cutting edges are less likely to bind and are easier to control.
- Check for misalignment or binding of moving parts, breakage of parts, and any other condition that may affect the tool's operation. If damaged, have the tool serviced before using. Many accidents are caused by poorly maintained tools.
- Use only accessories that are recommended by the manufacturer for your model. Accessories that may be suitable for one tool, may become hazardous when used on another tool.

SERVICE

- Tool service must be performed only by qualified repair personnel. Service or maintenance performed by unqualified personnel could result in a risk of injury.
- When servicing a tool, use only identical replacement parts. Follow instructions in the Maintenance section of this manual. Use of unauthorized parts or failure to follow Maintenance Instructions may create a risk of electric shock or injury.

OPERATING INSTRUCTIONS



Figure 1



Figure 2

IMPORTANT: You must read the safety instructions for this machine before use.

- 1 For best results it is recommended that the machine is positioned within 2 feet of the drain. **(see Fig. 1)**
- 2 Loosen the thumbscrew, pull sufficient cable out of the drum and place the end of the cable as far into the drain as possible.
- 3 Attach the drill motor cord to the air press box.
- 4 Attach the air foot switch to the press box. **(see Fig. 2)**
- 5 Plug the press box cord to the outlet. **(see Fig. 2)**
- 6 Pull approximately 5 feet of extra cable from the drum creating a slight loop of cable between the machine and the inlet. This should gently be fed into the inlet.
- 7 To operate, place the drill motor switch in the forward (FOR) position and depress the foot pedal.
- 8 DO NOT operate this machine in reverse. Operating the machine in reverse can result in cable damage and must only be used to help back a cable out of an obstruction.
- 9 Continue to push the cable into the sewer outlet or drainpipe using a gloved hand. Do not use a woolen glove. After feeding the cable in by hand, lock the thumbscrew onto the cable before squeezing the trigger again.
- 10 Once the obstruction has been cleared, the line should be washed through with a hose or power washer.

Note: It is recommended that the cable is continuously flushed through with clean water as it is being retrieved from the inlet and again before putting it away.

- 11 To retrieve the cable, first stop the machine. Then, feed all the cable into the drum, cleaning it in cold water as you go.
- 12 Finally, tighten the thumbscrew by hand.

Warning A: Do not allow the cable to get hung up on the obstruction. If the cable end gets hung up on an obstruction, stop the motor and reverse (REV) the drill until the cable becomes free. Once free from the obstruction, turn motor to the forward (FOR) position and resume clearance operation.

Warning B: Do not allow cables to become “over-stressed.” Over stressing cables due to a stubborn obstruction or snag will create tension in the cable leading to cable damage or an unpredictable cable reaction. If the cable becomes over-stressed, follow the same procedure as advised in “Warning A.”

Warning C: Never fully retract the cable from the inlet while it is rotating.

TO REMOVE DRUM

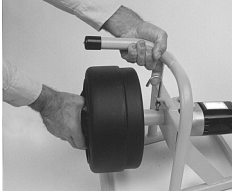

Figure 3

INSTALLING REPLACEMENT CABLE



Figure 4

- The release hook is situated immediately behind the drum. Pull hook upward and pull drum forward to remove it from the spindle. (see Fig. 3)
- TO REPLACE the drum, reverse the steps above.

- Loosen thumbscrew and remove the existing cable from the machine.
- Uncoil the new cable completely. Carefully insert the cable into the drum and continue doing so until installation is complete.
- Finally, tighten the thumbscrew. (see Fig. 4)

SPECIAL APPLICATIONS

Reverse Operation

Running this machine in reverse should only be done if the cable becomes blocked and only for a few seconds, enough to free the end of the cable. If the cable gets caught on an obstruction, immediately release the trigger and take your foot off the foot pedal to allow the machine to come to a complete stop. Fully tighten the thumbscrew and turn the drill switch to the (REV) position and depress the foot pedal. Grasp the cable with a gloved hand and pull it while jogging the trigger. When the cable is dislodged, place the drill motor switch in the forward (FOR) position, loosen the thumbscrew, and follow normal operating procedure.

Lubrication

Grease all exposed and moving parts.

Storage

The machine must be kept in a dry, safe place, out of the reach of children.

Cables

The metal cable should be thoroughly cleaned with water to prevent unpleasant odors and the damaging effects of drain cleaning compounds.

CUTTER SELECTION



Straight Boring Head

For use when exploring and breaking up blockages or returning samples to the surface to determine the correct tool to use.

Spear-Head

For exploring and breaking up stoppages.

Side Cutter

For use in cleaning pipes of various material clinging to pipe walls.

Grease Cutter

For cleaning any stoppages, rags, sticks, grease, etc – the all rounder.

PARTS

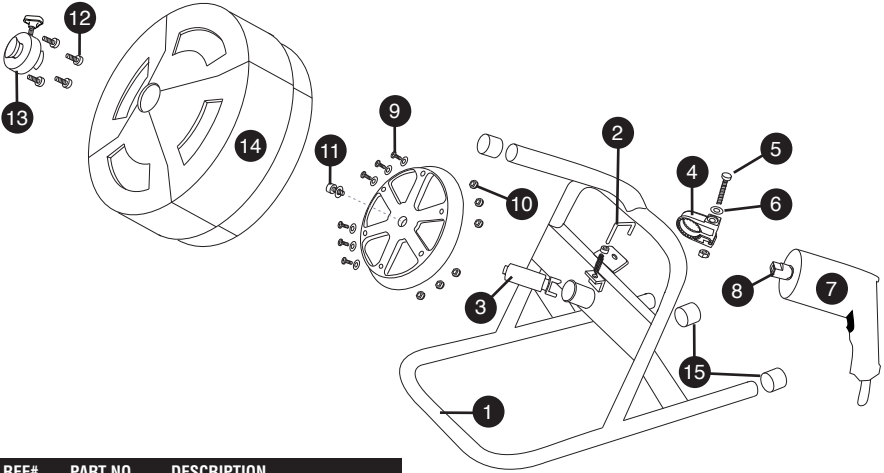

REF#	PART NO.	DESCRIPTION
1	850-990210	Frame Assembly
2	750-002000	Drum Pin Assembly
3	401-990273	Drum Drive
4	401-725550	Drill Attach Collar
5	350-142024	Large Shoulder Screw
6	350-313125	Flat Washer
7	99323	Drill
8	401-990274	Motor Drive
9	350-252558	Large Flat Head Cap Screw (6)
10	350-142040	Lock Nut (6)
11	350-375161	Large Socket Head Cap Screw (1)
12	350-142004	Large Button Head Screw (4)
13	850-990000	3/4" Nose cone Assembly
14	99318	Drum Assembly
15	450-043870	End Cap (3)
16	99300	Air Actuated Foot Switch
17	99301	Air Actuated Press Box

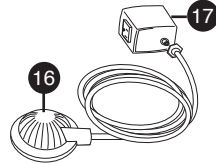

99206: 1/2' x 2" Side Cutter
For use in cleaning pipes of various material clinging to pipe walls.



99205: 1/2' x 1" Grease Cutter
For lines which have become badly greased with detergents and have to be re-opened.



99202: Straight Boring Head
For use when exploring and breaking up blockages or returning samples to the surface to determine the correct tool to use.



96204: Spear-Head
For exploring and breaking up stoppages.

BrassCraft®

1 Warner Court
Swedesboro, New Jersey 08085 USA

Customer Service..... **856-241-7700**
Fax Order Service..... **856-241-1699**