



Hydraulic Service Jack

Operating Instructions & Parts Manual

Model
AL2300

Capacity
3 Ton

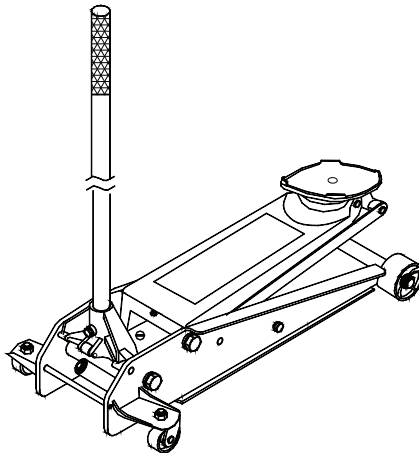

This is the safety alert symbol. It is used to alert you to potential personal injury hazards. Obey all safety messages that follow this symbol to avoid possible injury or death.

- ⚠ **WARNING:** Cancer and Reproductive Harm.
- ⚠ **AVERTISSEMENT:** Cancer et dommages au système reproducteur.
- ⚠ **ADVERTENCIA:** Cáncer y daño reproductivo.

www.P65Warnings.ca.gov

!WARNING



*To avoid crushing and related injuries:
NEVER work on, under or around a
load supported only by a hydraulic
jack. ALWAYS use an identical pair of
adequately rated jack stands.*

SFA Companies
10939 N. Pomona Ave. Kansas City, MO 64153

Read this manual and follow all the Safety Rules and Operating Instructions before using this product.

AL2300-MO_032020

SAFETY AND GENERAL INFORMATION

Save these instructions. For your safety, read, understand, and follow the information provided with and on this device before using. The owner and/or operator shall have an understanding of the device, its operating characteristics and safety operating instructions before operating the equipment. The owner and/or operator shall be aware that use and repair of this product may require special skills and knowledge. Instructions and safety information shall be read to and discussed with the operator in the operator's native language, making sure that the operator comprehends their contents, before use of this equipment is authorized. If any doubt exists as to the safe and proper use of this device, remove from service immediately.

Inspect before each use. Do not use if abnormal conditions such as cracked welds, damaged, loose or missing parts are noted. Any equipment that appears damaged in any way, is found to be worn, or operates abnormally shall be removed from service until repaired. If the equipment has been or is suspected to have been subjected to an abnormal load or shock, immediately discontinue use until inspected by a factory authorized repair facility (contact distributor or manufacturer for list of authorized repair facilities). It is recommended that an annual inspection be made by an authorized repair facility. Labels and Operator's Manuals are available from the manufacturer.

PRODUCT DESCRIPTION

This Hydraulic Service Jack is designed to lift, but not support, one end of a vehicle. Immediately after lifting, loads must be supported by a pair of appropriately rated jack stands.

⚠ WARNING: Do not use hydraulic jack as stand-alone support device. After lifting, immediately support the lifted vehicle with a pair of appropriately rated jack stands.

SPECIFICATIONS

Model	Capacity	Jack Size (l x w x h)	Min. Height	Max. Height	Saddle Dia.
AL2300	3 Ton	30-3/4" x 15" x 7-1/4"	5"	23-1/2"	6-3/4"

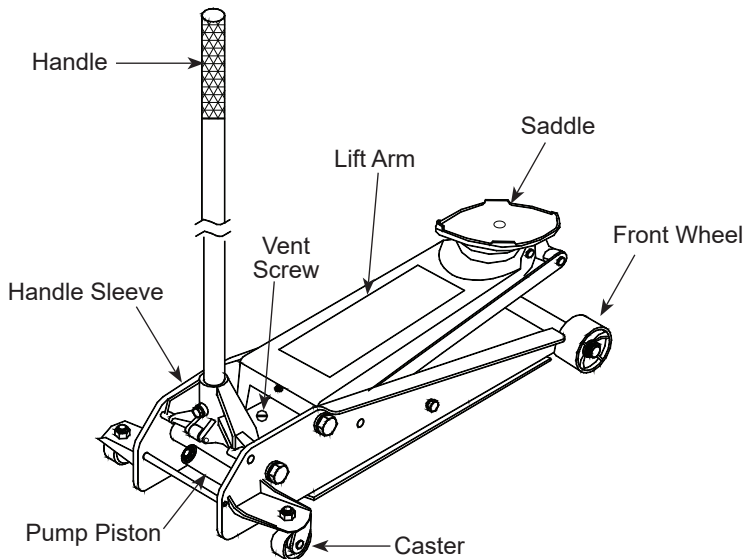

Figure 1 - AL2300 Service Jack Nomenclature

⚠ WARNING

- Study, understand, and follow all instructions before operating this device.
- Do not exceed rated capacity.
- Use only on hard, level surface.
- Lifting device only. Immediately after lifting, support the vehicle with appropriate means.
- Lift only on areas of the vehicle as specified by the vehicle manufacturer.
- Do not move or dolly the vehicle while on the jack.
- No alterations shall be made to this product.
- Failure to heed these markings may result in personal injury and/or property damage.

⚠ WARNING



To avoid crushing and related injuries:

- Never work on, under or around a load supported only by hydraulic jack.
- Always use adequately rated jack stands.
- Chock each unlifted tire in both directions.
- Do not use this device to lift, level, lower, support nor move a house, mobile home, travel trailer, camper or any building structure.
- Be alert and sober when using this product. Do not operate under the influence of drugs or alcohol.

PREPARATION

Assembly

Insert handle into the handle sleeve. Tighten the bolt on handle sleeve to prevent accidental removal of handle while in use.

⚠ WARNING: Do not lift or carry jack by handle. Handle could dislodge and jack fall, resulting in possible injury or property damage.

Before Use

1. Before using this product, read the operator's manual completely and familiarize yourself thoroughly with the product, its components and recognize the hazards associated with its use.
2. Verify that the product and application are compatible, if in doubt call Technical Service (816) 891-6390.
3. To familiarize yourself with basic operation, locate and turn the release valve (handle):
 - a. *Clockwise* until firm resistance is felt to further turning. This is the '**CLOSED**' release valve position used to **raise** the saddle.
 - b. *Counter-clockwise*, but no more than 1/2 turn from the closed position. This is the '**OPEN**' release valve position used to **lower** the saddle.
4. With saddle fully lowered, remove the oil filler plug. Pump 6 to 8 full strokes. This will help release any pressurized air which may be trapped within the reservoir. Check oil level. Proper oil level will vary from just covering the ram cylinder to 3/16" above it as seen from the oil filler hole. Reinstall the oil filler plug.
5. Ensure that jack rolls freely. Raise and lower the unloaded saddle throughout the lifting range before putting into service to ensure the pump operates smoothly. Replace worn or damaged parts and assemblies with authorized replacement parts only.

Bleeding/Venting Trapped Air

With the release valve in the OPEN position (step 3b. above) and with saddle fully lowered, locate and remove the oil filler plug. Pump 6 to 8 full strokes. This will help release any pressurized air which may be trapped within the reservoir. Reinstall the oil filler plug.

OPERATION

Lifting

1. Follow the vehicle manufacturer's recommended guidelines for lifting. Engage the emergency brake and chock each unlifted wheel in both directions to prevent inadvertent vehicle movement.
2. Close the release valve by turning the handle clockwise until firm resistance is felt.
3. Refer to the vehicle manufacturer owner's manual to locate approved lifting points on the vehicle. Center jack saddle under lift point.
4. Verify lift point, then pump handle to contact lift point. To lift, pump handle until load reaches desired height.
5. Transfer the load to appropriately rated jack stands.

Lowering

⚠ WARNING: *Clear all tools and personnel before lowering vehicle. Open release valve slowly. The further the pump handle is turned counter-clockwise, the faster the load will descend. Maintain control of load at all times.*

1. Raise load high enough to clear the jack stands.
2. Remove jack stands carefully (**always** used in pairs).
3. Slowly turn the handle counter-clockwise, but no more than 1/2 full turn. *If the load fails to lower:*
 - a. Use another jack to raise the vehicle high enough to reinstall jack stands.
 - b. Remove the malfunctioning jack and then the jack stands.
 - c. Use the functioning jack to lower the vehicle.
4. After removing jack from under the vehicle, fully lower the saddle to reduce ram exposure to rust and contamination.

MAINTENANCE

NOTICE: *Use premium quality hydraulic jack oil. Avoid mixing different types of fluid and do not use brake fluid, turbine oil, transmission fluid, motor oil or glycerin. Improper fluid can cause premature failure of the jack and the potential for sudden and immediate loss of load.*

Adding oil

1. With saddle fully lowered set jack in its upright, level position. Remove oil filler plug.
2. Fill with oil until ~3/16" above the inner cylinder as seen from the oil filler hole. Reinstall the oil filler plug.

Changing oil

For best performance and longest life, replace the complete fluid supply at least once per year.

1. With saddle fully lowered, remove the oil filler plug.
2. Lay the jack on its side and drain the fluid into a suitable container.

NOTICE: *Dispose of hydraulic fluid in accordance with local environmental regulations.*

3. Fill with oil until ~3/16" above the inner cylinder as seen from the oil filler hole. Reinstall oil filler plug.

Lubrication

A periodic coating of light lubricating oil to pivot points, axles and hinges will help to prevent rust and assure that wheels, casters and pump assemblies move freely.

Cleaning

Periodically check the pump piston and ram for signs of rust or corrosion. Clean as needed and wipe with an oily cloth.

NOTICE: *Do not use sandpaper or abrasive material on ram and pump piston surfaces.*

Storage

When not in use, store the jack with saddle fully lowered.

REPLACEMENT PARTS

(ref. page 7 for part numbers)

Not all components of the jack are replacement items, but are illustrated as a convenient reference of location and position in the assembly sequence. When ordering parts, please give the Model number, part number and parts description. Call or write for current pricing: SFA Companies 10939 N. Pomona Ave. Kansas City, MO 64153, U.S.A. Tel: (888) 332-6419; Fax: (816) 891-6599

Key Number	Replacement Part Number	Description
1	231584	Rear Caster
2	234968	Handle
3	248731	Universal Joint
4	234677	Front Wheel Assy
5	G750-00000-000	Power Unit
6	239304	Saddle
7	6420-10000-000	Air Vent w/Gasket
8	234956	Handle Retaining Bolt
9	243618	Return Spring (2 pc.)
10	890-021-666	Pump Piston Assembly

*Replacement parts may not have matching colors.

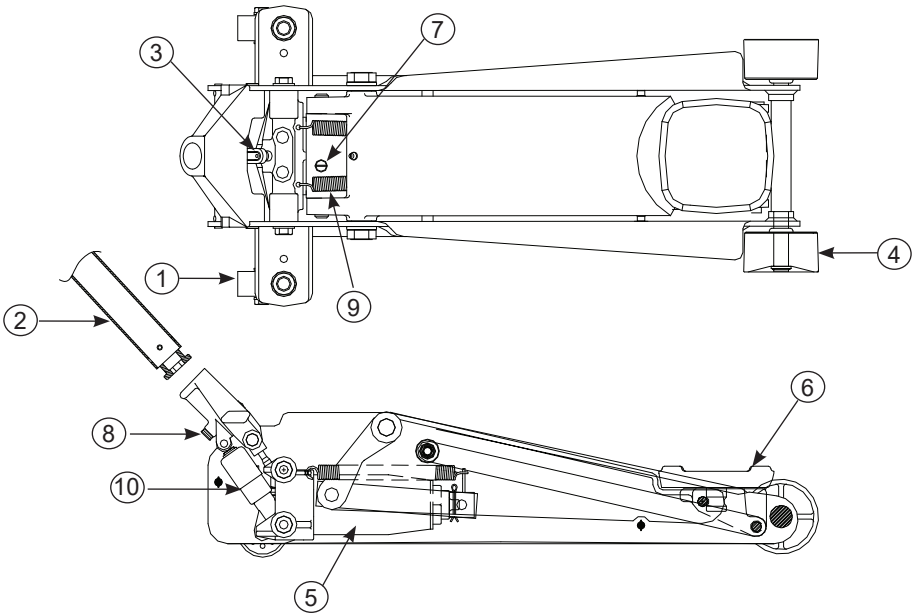

Figure 2 - Replacement Parts Illustration for Model AL2300

TROUBLESHOOTING

Symptom	Possible Causes	Corrective Action
Jack will not lift load	<ul style="list-style-type: none"> • Release valve not tightly closed • Load is too heavy 	<ul style="list-style-type: none"> • Ensure release valve tightly closed • Consider higher capacity jack
Jack will lift, but not maintain pressure	<ul style="list-style-type: none"> • Release valve not tightly closed • Hydraulic unit malfunction 	<ul style="list-style-type: none"> • Ensure release valve tightly closed • Discontinue use, contact technical service
Jack will not lower after unloading	<ul style="list-style-type: none"> • Reservoir overfilled • Linkages binding • Fluid level low 	<ul style="list-style-type: none"> • Drain fluid to proper level • Clean and lubricate moving parts • Ensure proper fluid level
Poor lift performance	<ul style="list-style-type: none"> • Fluid level low • Air trapped in system 	<ul style="list-style-type: none"> • Ensure proper fluid level • Follow Bleeding/Venting Trapped Air procedure (page 3)
Will not lift to full extension	<ul style="list-style-type: none"> • Fluid level low 	<ul style="list-style-type: none"> • Ensure proper fluid level

TWO YEAR LIMITED WARRANTY

For a period of two (2) years from date of purchase, SFA Companies will repair or replace, at its option, without charge, any of its products which fails due to a defect in material or workmanship under normal usage. This limited warranty is a consumer's exclusive remedy.

Performance of any obligation under this warranty may be obtained by returning the warranted product, freight prepaid, to SFA Companies Warranty Service Department, 10939 N. Pomona Ave., Kansas City, MO 64153.

Except where such limitations and exclusions are specifically prohibited by applicable law,

(1) THE CONSUMER'S SOLE AND EXCLUSIVE REMEDY SHALL BE THE REPAIR OR REPLACEMENT OF DEFECTIVE PRODUCTS AS DESCRIBED ABOVE.

(2) SFA Companies SHALL NOT BE LIABLE FOR ANY CONSEQUENTIAL OR INCIDENTAL DAMAGE OR LOSS WHATSOEVER.

(3) ANY IMPLIED WARRANTIES, INCLUDING WITHOUT LIMITATION THE IMPLIED WARRANTIES OF MERCHANTABILITY AND FITNESS FOR A PARTICULAR PURPOSE, SHALL BE LIMITED TO ONE YEAR, OTHERWISE THE REPAIR, REPLACEMENT OR REFUND AS PROVIDED UNDER THIS EXPRESS LIMITED WARRANTY IS THE EXCLUSIVE REMEDY OF THE CONSUMER, AND IS PROVIDED IN LIEU OF ALL OTHER WARRANTIES, EXPRESS OR IMPLIED.

(4) ANY MODIFICATION, ALTERATION, ABUSE, UNAUTHORIZED SERVICE OR ORNAMENTAL DESIGN VOIDS THIS WARRANTY AND IS NOT COVERED BY THIS WARRANTY.

Some states do not allow limitations on how long an implied warranty lasts, so the above limitation may not apply to you. Some states do not allow the exclusion or limitation of incidental or consequential damages, so the above limitation or exclusion may not apply to you. This warranty gives you specific legal rights, and you may also have other rights, which vary from state to state.



SFA Companies
10939 N. Pomona Ave. Kansas City, MO 64153
816-891-6390



SFA Companies
10939 N. Pomona Ave. Kansas City, MO 64153
816-891-6390



SFA Companies
10939 N. Pomona Ave. Kansas City, MO 64153
816-891-6390