



**Please do not return this product to the retailer!!!**

If you find that you have any trouble with assembly or missing or damaged parts please contact us at:

**1-800-815-4796**

Or via the web at:

<http://www.crosleyfurniture.com/#/contactUs>





# INTERNATIONAL

PLEASE REVIEW THIS WARRANTY POLICY IN ITS ENTIRETY.

## LIMITED MANUFACTURERS WARRANTY

If this product was purchased outside of the Continental United States or Canada please refer to [www.crosleyradio.com/international](http://www.crosleyradio.com/international) for information about an Authorized Crosley Distributor in your area. The terms and conditions listed below will apply for North American and Canadian customers.

### CONSUMER ELECTRONICS WARRANTY POLICY

Every Crosley product we sell is designed to meet and exceed your expectations. We are dedicated to providing excellent quality. However, sometimes electronics products have technical difficulties. Before determining that your product is indeed malfunctioning, please consult our TROUBLESHOOTING tips as well as your user manual for proper usage. If you have product questions outside the scope of the troubleshooting tips and manual instructions, it is best to contact our Consumer Support Team for assistance.

If a defect exists, Crosley, at its discretion, will:

- Request that the item is returned to the retailer from where it was purchased IF the malfunction occurs within said retailer's standard return period.
- Repair the product at no charge using new (or refurbished) parts at their discretion.
- Exchange the product with a functional equivalent.

Crosley Radio Products are warranted against defects in material and workmanship for a period of one year beginning from the date of sale to the original purchaser. The warranty does not cover damage due to acts of nature, accident, misuse, abuse, negligence, commercial use or modification of, or to any part of the product. This warranty does not cover damage due to improper operation or maintenance, connection to improper voltage supply, or attempted repair by anyone other than a facility authorized by Crosley Radio to service the product. This warranty does not cover products sold AS IS, demo products, returns or second hand purchases or consumables (such as fuses or batteries, needles, and belts). This warranty is valid only in the Continental United States, Canada and areas serviced by an Authorized Crosley International Distributor.

Should the unit fail under normal usage during the warranty period, a request for RETURN AUTHORIZATION (R.A.) must be made by the original purchaser before returning the unit. Call our Consumer Support Team for RETURN AUTHORIZATION and a PREPAID shipping label at 1-866-CROSLEY from 8 AM to 6 PM (EST) Monday through Friday or submit a support request at [www.CrosleyRadio.com/support](http://www.CrosleyRadio.com/support). Canadian customers may be subject to an additional fee for customs, duties, and taxes.

\*International Customers may visit us at [www.CrosleyRadio.com/International](http://www.CrosleyRadio.com/International) for contact information for an Authorized Crosley Distributor in your area.

Upon receiving the RETURN AUTHORIZATION number from our Consumer Support Team, properly pack your unit in its original packing. Include any adapters, parts, & accessories which were originally provided with the product. Display the R.A. # on the outside of carton and drop the unit off at a local FedEx store or contact FedEx for pickup. Crosley Radio assumes no responsibility for units sent without prior Return Authorization, or for fees associated with packaging, pickups and call tags.

**The purchaser's bill of sale from an Authorized Crosley Distributor/Retailer is the only proof of warranty entitlement and must be provided in the event of a request for parts or service under warranty.**

### FURNITURE WARRANTY POLICY

Crosley Furniture Products are warranted against defects in material and workmanship for a period of 90 days beginning from the date of sale to the original purchaser. The warranty does not cover damage due to acts of nature, accident, misuse, abuse, negligence, commercial use or modification of, or to any part of the product. This warranty does not cover damage due to improper operation, care and maintenance outside of the supplied literature accompanying the unit or available at [www.CrosleyFurniture.com](http://www.CrosleyFurniture.com) or attempted repair or alteration by the purchaser or anyone other than a facility authorized by Crosley Furniture to service the product. This warranty does not cover products sold AS IS, demo products, returns or second hand purchases or consumables (such as fuses or batteries).

Should you experience any damaged, defective, or missing parts, or need help with assembly please call our Consumer Support Team at 1-800-815-4796 from 8 AM to 6 PM (EST) Monday through Friday or submit a support request at [www.CrosleyFurniture.com/#/contactUs](http://www.CrosleyFurniture.com/#/contactUs).

\*International Customers may visit us at [www.CrosleyFurniture.com/International](http://www.CrosleyFurniture.com/International) for contact information for an Authorized Crosley Distributor in your area.

**The purchaser's bill of sale from an Authorized Crosley Distributor/Retailer is the only proof of warranty entitlement and must be provided in the event of a request for parts or service under warranty.**

### DISCLAIMER

This Limited Warranty is the only express warranty made to the consumer and is provided in lieu of any other express warranties or similar obligations (if any) created by any advertising, documentation, packaging, or other communications.

EXCEPT FOR THE LIMITED WARRANTY AND TO THE MAXIMUM EXTENT PERMITTED BY APPLICABLE LAW, CROSLEY BRANDS (MODERN MARKETING CONCEPTS INC.) HEREBY DISCLAIMS ALL OTHER WARRANTIES AND CONDITIONS, WHETHER EXPRESS, IMPLIED OR STATUTORY, INCLUDING, BUT NOT LIMITED TO, THE IMPLIED WARRANTY OF MERCHANTABILITY OR OF FITNESS FOR A PARTICULAR PURPOSE. IN NO EVENT SHALL CROSLEY BRANDS (MODERN MARKETING CONCEPTS INC.) OR ITS SUPPLIERS BE LIABLE TO THE CONSUMER OR ANY THIRD PARTY FOR ANY INDIRECT, INCIDENTAL, CONSEQUENTIAL, SPECIAL OR EXEMPLARY DAMAGES ARISING OUT OF THE USE OF THE PRODUCT, INCLUDING, WITHOUT LIMITATION, PROPERTY DAMAGE, LOSS OF VALUE OF THE PRODUCT OR LOSS OF USE OF THE PRODUCT, EVEN IF CROSLEY BRANDS (MODERN MARKETING CONCEPTS INC.) HAS BEEN ADVISED OF THE POSSIBILITY OF SUCH DAMAGES.

### FINE PRINT

Your retailer or Authorized Crosley Distributor is responsible for any malfunctions during their specified return period. This warranty gives you specific legal rights, and you may have other rights that vary by state and jurisdiction. These rights shall not be affected by this limited warranty. This warranty cannot be transferred or reassigned. There are no express warranties except as listed above.

**The original purchaser's bill of sale is the only proof of warranty entitlement on any Crosley Product.**

In accordance with the "Moss-Magnuson Warranty Act" of July 10, 1975, this is termed a "limited warranty" which in no way compromises Crosley Brands high standards of quality and workmanship



## USE & CARE INSTRUCTIONS

*Please read Use & Care Instructions in its entirety prior to assembling and utilizing your Crosley Furniture.*

### KEEPING YOUR FURNITURE BEAUTIFUL

Quality furniture is a significant investment expected to last for years on end. To maintain its beauty and help it last, furniture needs the right care. No finish is totally indestructible. But with regular care, the finish and materials will last much longer, providing years of enjoyment.

#### Tips to Protect and Care for Your Furniture

1. Avoid placing your furniture directly under windows, or in direct sunlight, as sunlight causes fading.
2. Avoid extreme changes in temperature by arranging furniture away from radiators, heat and air vents and air conditioning units.
3. Avoid placing plastic, adhesives or rubber materials (lamp bases, notebooks, placemats, etc.) on your furniture, as certain plastics contain ingredients that may damage the finish.
4. Periodically rotate accessories on furniture so they do not sit in the same spot all the time.
5. Use pads, cloth or felt to protect the furniture surface from plastic, rubber, hot dishes, beverages, bookends, flowerpots and vases and use a protective pad when writing on the furniture surface.
6. On Kitchen Carts and Islands, specifically, use cutting boards and trivets for food preparation in order to avoid damaging the top for the unit.
7. Clean up spills immediately. Use a blotting rather than a wiping action. Water left over a long period of time will cause white spots in the finish. Alcohol, perfume, after-shave and certain medications can cause severe finish damage.
8. Lift and place objects rather than dragging them across the furniture surface.

**Wood Furniture Care:** We recommend dusting frequently with a clean, soft, dry, lint-free cloth. Clean the surface by rubbing in the direction of the grain. We recommend polishing your furniture approximately every six months, using a clean, soft, lint-free cloth and rubbing the polish in the direction of the grain. Guardsman Furniture Polish © or any furniture polish that doesn't contain silicone is recommended.

**Leather Furniture Care:** Wipe spills immediately with clean cloth or sponge. For spots or stains and daily cleaning, clean with mild non-detergent soap. Rinse well, gently wipe off, and allow to air dry. Regarding Cleaning Butter, Oil or Grease for Leather; Wipe leather with a clean cloth, and leave alone. The oil will be absorbed by the leather. DO NOT APPLY WATER. Also, do not use saddle soap, cleaning solvents, furniture polish, oils, varnish, abrasive cleaners, ammonia or any other type of chemical solution.

**Granite Care:** Our granite is not sealed, so you may want to apply an over-the-counter sealant, which will provide a small amount of surface protection, but we still recommend cleaning spills promptly. Use a slightly damp cloth to clean as needed. Wipe dry. We also do not recommend using abrasive cleaners, chemical solvents, strong detergents, cleaners with bleach, and furniture polish. Be sure to use trivets, coasters, placemats, and adhesive felt pads to help prevent scratches.

**Butcher Block Care:** For best results, clean finished butcher block surfaces with soapy water or commonly available kitchen counter top cleaners. Do not use abrasives or powder cleansers. Do not allow moisture to stand on the surface for prolonged periods of time. To sanitize, rinse the butcher block with white vinegar by using a vinegar-water solution in a spray bottle. Spritz the butcher block all over, and let it sit for a while. While that sits, make a lemon salt mixture by pouring about 1/4 cup salt into a bowl, and stir in enough lemon juice to make a workable paste, adjusting the consistency as you go. Then use a scrub brush to thoroughly scrub your butcher block with the lemon-salt paste. If the paste gets too dry, sprinkle on a little more lemon juice. Rinse well, and squeegee off as much water as you can, and then let it dry overnight. Make sure to seal it before you get it dirty again. Pour out a small amount of oil, and rub it into the wood using a cloth or paper towel. As the oil soaks in, add more and continue rubbing and polishing with the grain until the oil is absorbed. The first time you seal your butcher block, it may take several applications before it stops "drinking" oil, but in later cleanings you'll just need to refresh it. Keep adding oil until no more soaks in, remove any excess with a cloth.

**Stainless Steel Care:** Stainless Steel tops should always arrive unblemished. Depending on usage, overtime you will begin to notice that your stainless steel may develop a sheen (often light bronze or copper green in color). This is called a 'patina' and is completely normal. This is the distressed and vintage look of metals from the natural process of oxidation, regular use, and exposure to environment. It will vary depending on these factors and is not a defect of the material. To clean, avoid using harsh abrasives unless absolutely necessary as this will lead to excessive scratching of the surface. Generally a solution of vinegar and water or household streak free window cleaner is sufficient along with a soft cloth or paper towel. Spray your top lightly with vinegar/water or window cleaner and rub in the direction of the grain of the metal finish until clean.

**Resin Wicker Furniture Care:** Regular cleaning is recommended for wicker, as it generally cannot endure harsh or abrasive treatments. This also minimizes mildew buildup. To remove dirt and debris, vacuum with a dust-brush attachment or use a dry paintbrush. Clean with a mild soap solution. Scrub, and rinse. Avoid sitting on the wicker when still damp, which can cause wicker to sag. Please always cover the furniture when not in use, and store properly during inclement weather and the winter/rainy seasons. If wicker furniture is caught during a sudden rain storm, please make sure to drain any water that may have accumulated inside the frame.

**Metal Furniture Care:** Because most metals, except aluminum, are subject to rust, metal furniture is usually finished with layers of clear varnish, paint, or a durable powder coating. Use a mild soap solution, and scrub, rinse, and dry. Do not use products such as Brasso © as this may lead to the accidental removal of antique finishes and also to staining or damage to surrounding areas of fabric (IE Bed Buttons). On outdoor furniture, make sure to drain any water that may accumulate inside the frames after rinsing. After cleaning, apply a coat of quality liquid or paste auto wax with a lint-free cloth. Use a silicone spray to lubricate swivels and glides on chairs. If metal outdoor furniture is caught during a sudden rain storm, please make sure to drain any water that may have accumulated inside the frame.

**Fabric Materials Care:** For Linen – If the linen item is removable, place the item in a clean sink or tub with cool water and a mild detergent. Gently agitate the linen items, then remove from the soapy water. Rinse with cool water and hang dry. If not removable, then spot clean by dabbing with solution of cool water and a mild detergent on a soft non-abrasive cloth. For Microfiber - If the microfiber item is removable, (cushion/canopy covers, drapes, etc.) machine wash in warm or hot water with mild detergent. No fabric softeners as they will clog the open spaces in the microfiber, making the fabric useless. Be careful what you wash with your microfiber. Avoid anything made with cotton because the microfiber will grab on to the lint. If not removable, prevent stains as much as possible by removing crumbs, dust, dirt, and debris. Clean spills immediately! For stain removal, load a spray bottle with generic rubbing alcohol and spray the area lightly; using a soft cloth and a blotting motion to remove the stain. Allow area to air dry.

**Outdoor Cushion Care:** Our cushions are made from a high density polyester foam, and the covers are made from a moisture resistant polyester blend. This does not mean they are waterproof! We do not recommend leaving cushions out in inclement weather, and if cushions become wet, please dry them immediately by removing the cushion from the cover so they can dry separately. Wring out any excess moisture before drying. Air dry only! Cushion covers are machine washable (gentlest cycle with like colors and cold water), and we recommend separating the cushion cover from the core for any cleaning purposes. Cushions should be stored and covered when not in use to protect them from rain, sunlight, and other staining agents.

**MOISTURE  
RESISTANT**



**WATERPROOF**



**Outdoor Furniture Storage:** We highly recommend storing any outdoor furniture during the winter and/or rainy seasons. Before storing your furniture, please ensure all moisture collected in the frame tubes has been drained. When outdoor furniture is not in use, we recommend covering all the furniture to protect it against the elements. If outdoor furniture is caught during a sudden rain storm, please make sure to drain any water that may have accumulated inside the frame.

**Outdoor Cover Care:** Our covers are made from heavy gauge and reinforced vinyl making them waterproof. We recommend hand washing in lukewarm water and allowing to fully air dry before reusing or storing. We do not recommend using a washing machine or soaps and detergents as it may destroy the protective coatings. Remove the covers periodically to check for moisture build-up.

**Coastal Customers:** Due to the corrosive nature of salt, extra care must be taken due to the higher salinity in the air as well as the possibility of direct contact from sea spray. Keep outdoor metal/wicker furniture covered when not in use, and rinse with fresh water on a regular basis to prevent salt accumulation. Make sure to drain any water that may accumulate inside the frames after rinsing. Additional protection in the form of protective transparent sealer is recommended as well.

**Fire Pit/Table Care:** Crosley wood burning fire pits are only rated for a 'decorative' or 'recreational' burn from 350 to 500°F. Anything higher/larger than that may require additional protection from a third party paint application such as Krylon © 'Max Heat' which is rated for 1200° F. Crosley does NOT support the use of our fire pit/table(s) outside of these temperature and usage recommendations due to obvious safety reasons. It is recommended to cover the fire pit with a tarp (or provided cover depending on model) when not in use.

**⚠️ PROPOSITION 65 WARNING:** Burning fireplace or wood stove fuels such as natural firewood results in emission of carbon monoxide, soot, and other combustion by-products which are known by the State of California to cause cancer, birth defects, or reproductive harm. For more information, go to: [www.P65Warnings.ca.gov](http://www.P65Warnings.ca.gov).







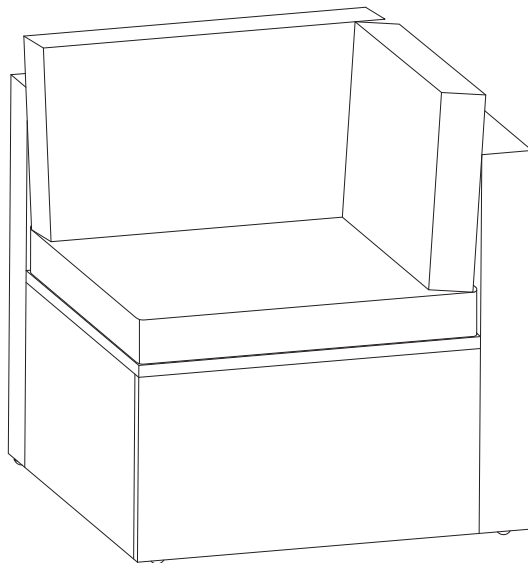

*As products are improved upon and new products are released, our Use and Care Instructions are regularly updated at:  
[useandcare.crosleyfurniture.com](http://useandcare.crosleyfurniture.com)*

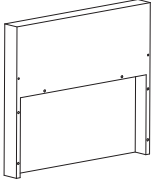
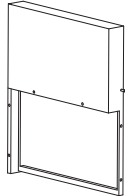

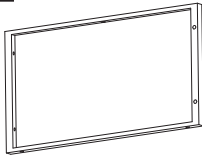
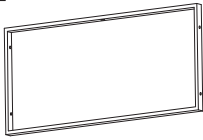



Outdoor Wicker Corner Chair  
CO7147



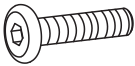
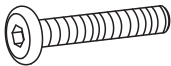
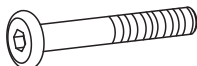

# PART LIST

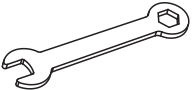
				
<p>Arm Panel 1 PC</p>	<p>Back Panel 1 PC</p>	<p>Seat Panel 1 PC</p>	<p>Front Panel 1 PC</p>	<p>Side Panel 1 PC</p>
				
<p>Cover of Seat Cushion * 1 PC</p>	<p>Core of Seat Cushion 1 PC</p>	<p>Cover of Back Cushion * 1 PC</p>	<p>Core of Back Cushion 1 PC</p>	<p>Cover of Side Cushion * 1 PC</p>
	<p>*Please note cushion covers will ship separately.</p>			
<p>Core of Side Cushion 1 PC</p>				

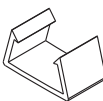
# HARDWARE LIST

 <p>M6*30mm</p>	 <p>M6*40mm</p>	 <p>M6*50mm</p>	 <p>M6mm</p>	 <p>M6mm</p>
<p>Short Bolt 4 PCS</p>	<p>Medium Bolt 4 PCS</p>	<p>Long Bolt 6 PCS</p>	<p>Nut 10 PCS</p>	<p>Washer 24 PCS</p>
 <p>M6mm</p>	 <p>M6mm</p>	 <p>M6mm</p>		
<p>Wrench 1 PC</p>	<p>Allen Key 1 PC</p>	<p>Adjustable Leveler 4 PCS</p>	<p>Plastic Clip 2 PCS</p>	

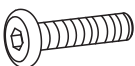
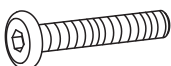
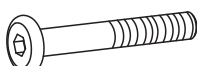
# EXTRA HARDWARE LIST

 <p>M6*30mm</p>	 <p>M6*40mm</p>	 <p>M6*50mm</p>	 <p>M6mm</p>	 <p>M6mm</p>
<p>Short Bolt 1 PC</p>	<p>Medium Bolt 1 PC</p>	<p>Long Bolt 2 PCS</p>	<p>Nut 2 PCS</p>	<p>Washer 3 PCS</p>

Step 1. Lay arm panel (part A) down on a soft flat surface, such as carpet, as shown below. Attach back panel (part B) to arm panel (part A) using medium bolts (part #2), washers (part #5), nuts (part #4), wrench (part #6) and allen key (part #7).

NOTE: Please do not fully tighten bolts until unit is fully assembled.

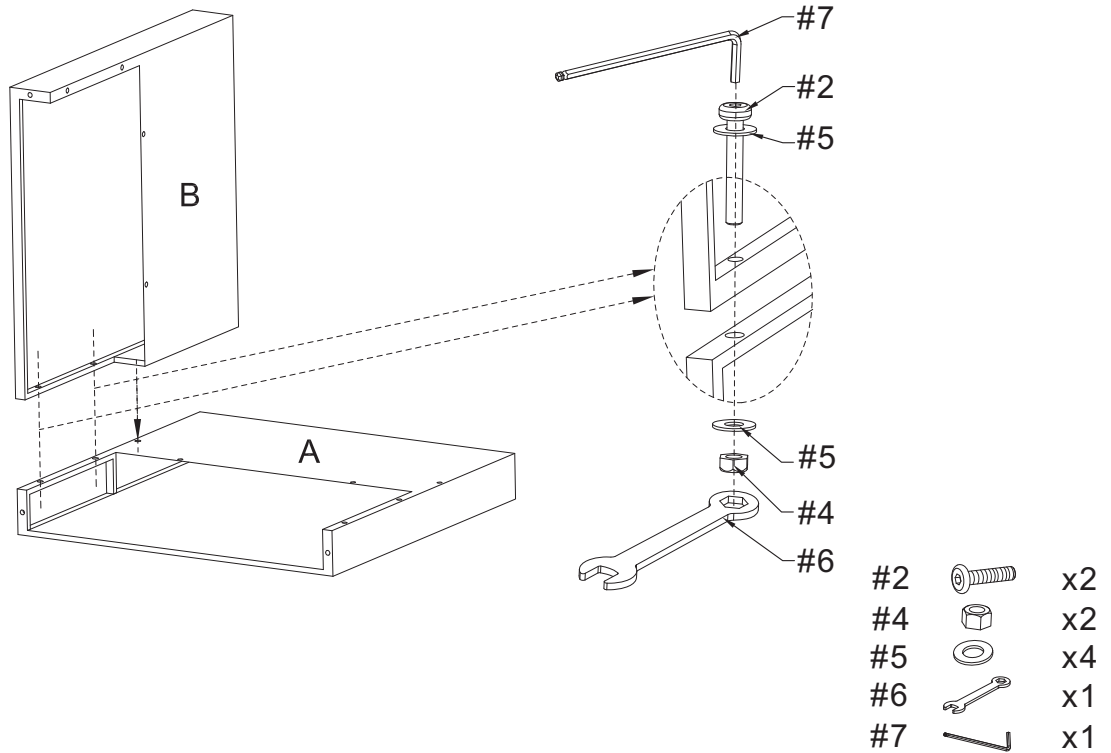

Step 2. Attach seat panel (part C) to arm panel (part A) and back panel (part B) using long bolts (part #3), washers (part #5), nuts (part #4), wrench (part #6) and allen key (part #7).

NOTE: Please do not fully tighten bolts until unit is fully assembled.

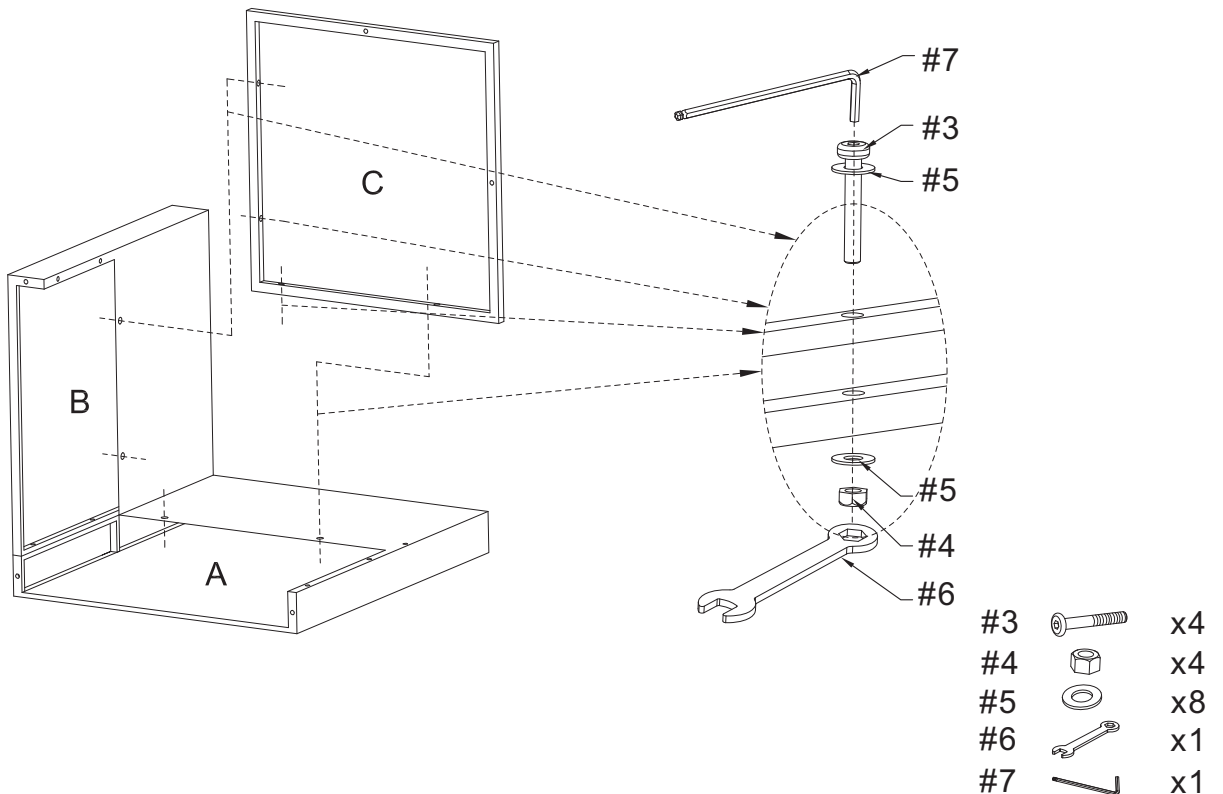



Step 3. Attach front panel (part D) to arm panel (part A) and seat panel (part C) using short bolts (part #1), long bolts (part #3), washers (part #5), nuts (part #4), wrench (part #6) and allen key (part #7).

NOTE: Please do not fully tighten bolts until unit is fully assembled.

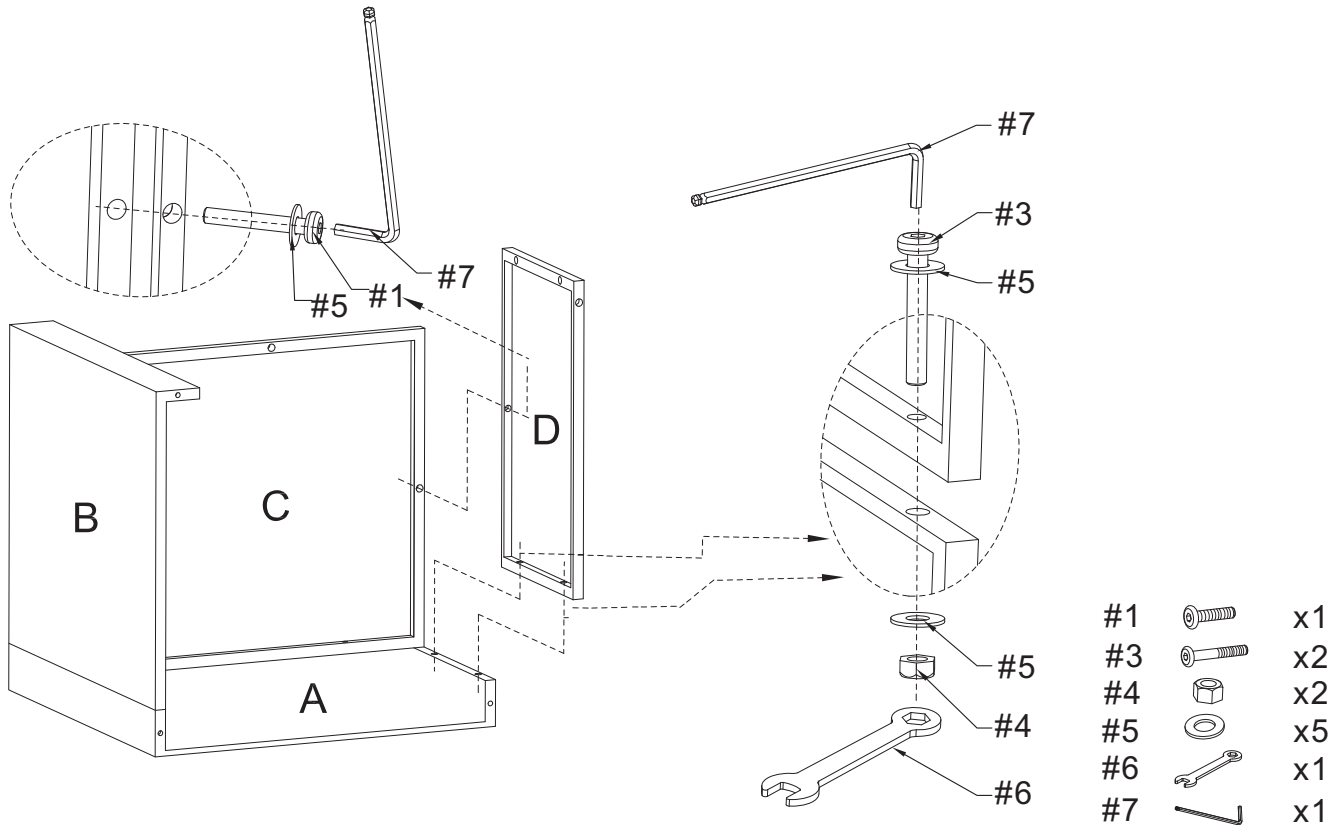

Step 4. Attach side panel (part E) to assembled unit (parts B, C & D) using short bolts (part #1), medium bolts (part #2), washers (part #5), nuts (part #4), wrench (part #6) and allen key (part #7).

NOTE: Please fully tighten all bolts at this time.

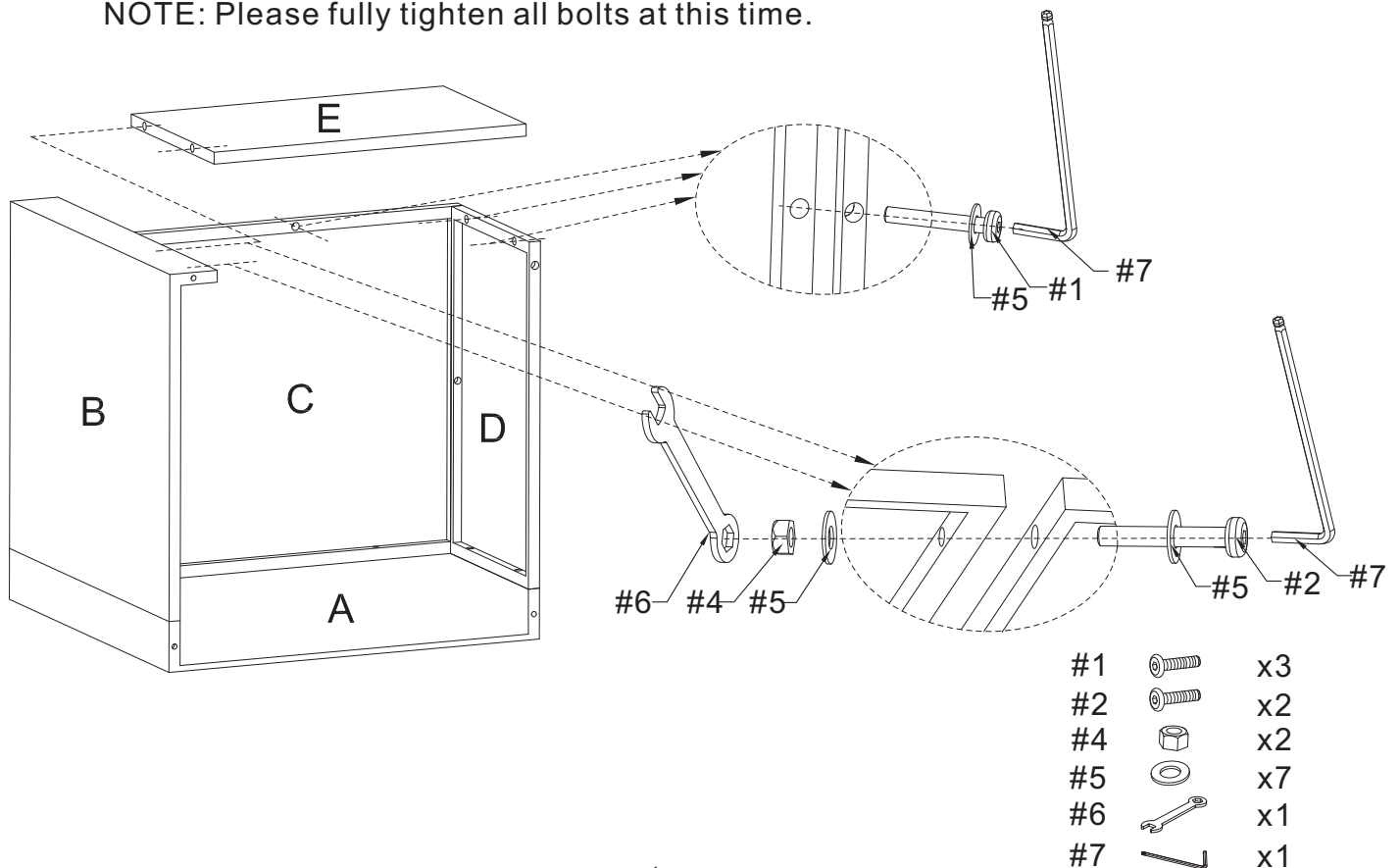



Step 5. Screw adjustable levelers (part #8) to desired position in the pre-drilled holes on the bottom of the chair where shown.

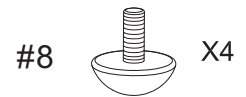
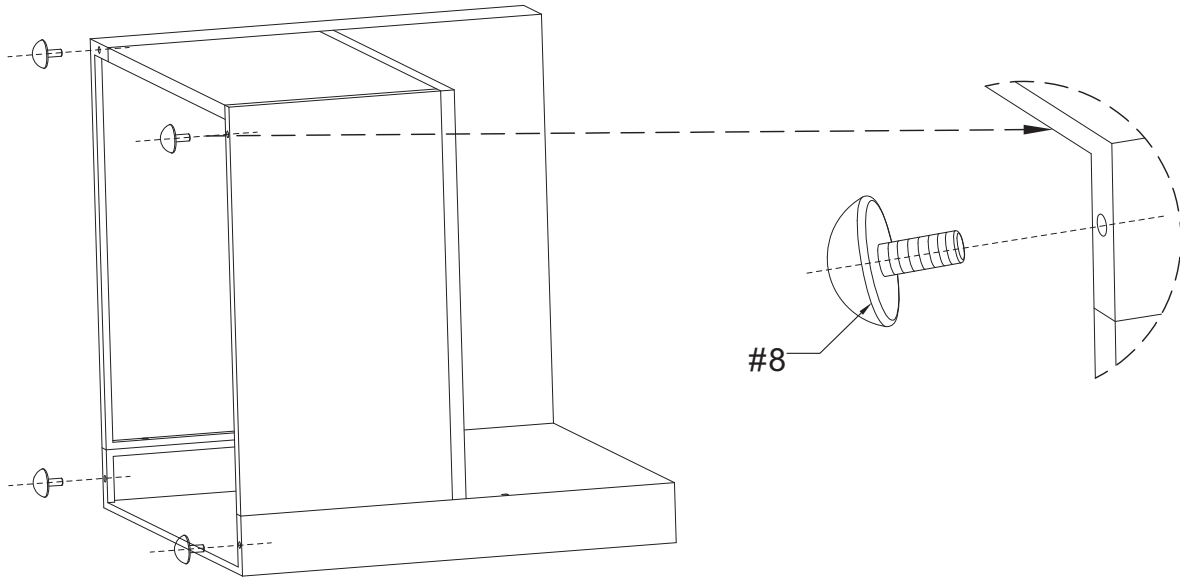

Step 6. Insert core of seat cushion (part G) into cover of seat cushion (part F).  
Insert core of back cushion (part I) into cover of back cushion (part H).  
Insert core of side cushion (part K) into cover of side cushion (part J).

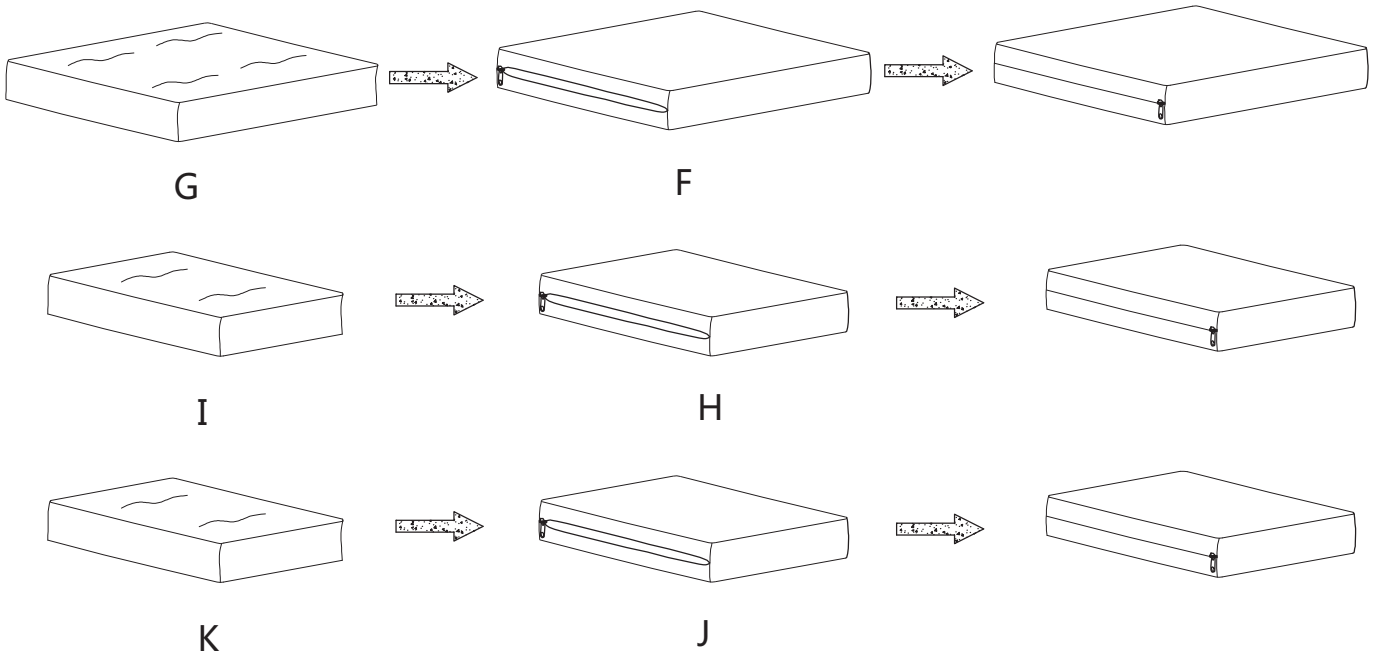

Step 7. Carefully turn the assembled chair upright and add cushions as shown below.

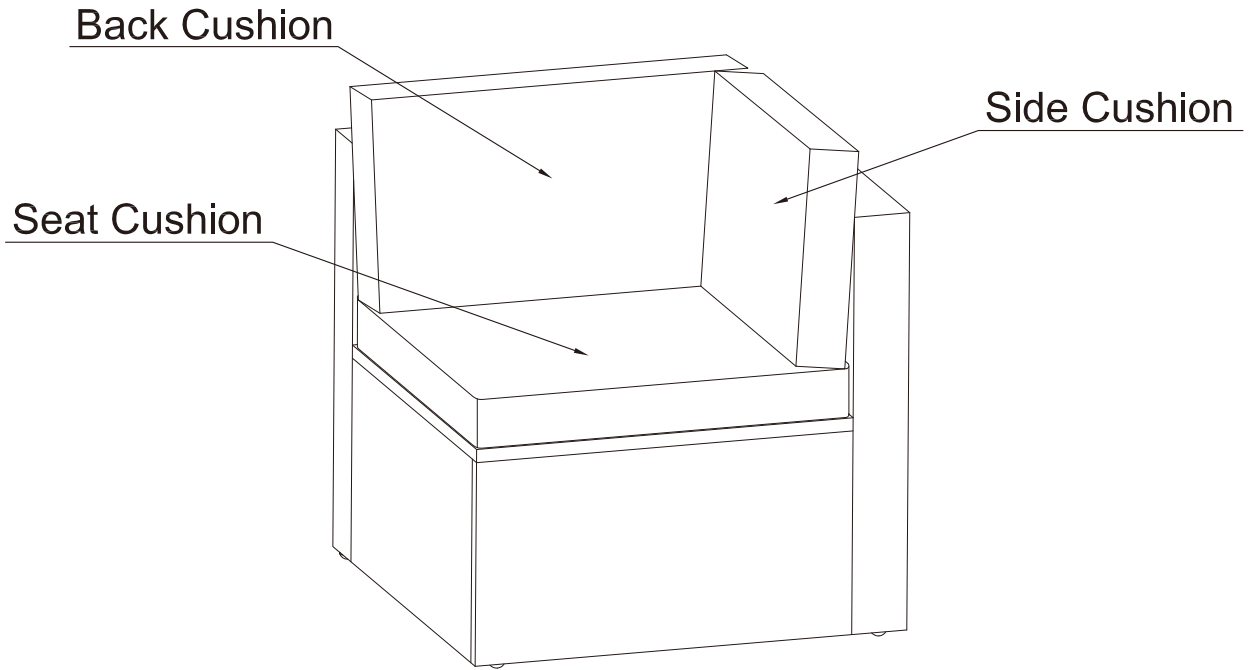

Step 8. Use plastic clips (part #9) to secure additional units together as shown.

