

AQUASURE

Quantum UV

WHOLE HOUSE MULTISTAGE
WATER FILTRATION SYSTEM WITH
ULTRA VIOLET (UV) WATER PURIFIER

OWNER'S MANUAL

⚠ IMPORTANT!

For optimum performance and protection against contaminants, please thoroughly read this owner's manual before proceeding with the installation.



Copyright © 2022 Aquasure USA

All rights reserved. No portion of this product manual may be reproduced in any form without permission from the publisher, except as permitted by U.S. copyright law. For permissions contact: marketing@aquasureusa.com

TABLE OF CONTENTS

Welcome 4

System Registration 5

System Inspection 6

Installation Diagram 7

Safety Instructions 8

Operation Parameter 9

System Installation 10

Flushing and Testing the Plumbing Lines 17

System Startup 17

Replacing your filters & UV components 19





Maintenance 20

System Warning & Troubleshooting 22

System Warning & Troubleshooting 23

Using the system gauges 25

Warranty 26

LEGEND	
	CAUTION
	EYE PROTECTION
	ELECTRICAL WARNING
	PROTECTIVE GROUND
	FRAGILE

WELCOME & CONGRATULATIONS

Thank you for choosing Aquasure. This owner's manual will guide you through the necessary steps to install your Aquasure Quantum Whole House Filtration System with UV Water Purifier.

For MAXIMUM effectiveness please thoroughly read this manual.

The information listed in this manual covers the steps for a self-serve installation. In the event that you need support, our technicians are available to answer any questions during hours of operation as listed below.

Scan the QR code for support

Telephone:
(800) 661-0680
M-F 8:30AM - 5:30PM PST

Email:
support@aquasureusa.com

Online Chat:
aquasureusa.com/support



Get Familiar with the System Before Installation

Please read the entire manual and become familiar with the instructions and parts needed before proceeding with the installation. Hiring a professional plumber who will adhere to all local, state and federal guidelines is recommended for a proper installation.

SYSTEM REGISTRATION

DON'T MISS OUT ON TWO FREE YEARS WITH AQUASURE EXTENDED WARRANTY.

Register your product within 60 Days from time of purchase to extend your Aquasure system warranty for FREE. Simply visit aquasureusa.com/support or follow the steps below.

Registration with your mobile device is easy.

1. Fill out the form below and take a picture.
2. Scan the QR code with your device camera and click the banner.
3. Attach the picture of the completed form to the email that opens.
4. Hit Send and you're DONE!

Purchaser Name: _____

Email: _____

Phone: _____

Street Address: _____

City: _____

State/Province: _____ Zip/Post Code: _____

Order Number: _____ Order Date: _____

Serial Number: _____

Place of Order: _____

Aquasure Quantum UV Multi-Stage Warranty Form

Scan this QR code to email the completed form above to our Aquasure support team.



Where to find your serial number

Your system's serial number can be found near the top of the UV chamber inside the top housing.



SYSTEM INSPECTION

Please take the system and all the components out of the box. Inspect the system and all the connection fittings carefully, make sure nothing is damaged during shipping. If any part is cracked or broken, please do not proceed with the installation. Contact Aquasure or your distributor for an exchange or diagnosis.



IMPORTANT:

Leave the UV lamp and UV quartz sleeve inside the packaging until ready for installation. Do not touch the glass on the UV quartz sleeve or UV lamp without the use of plastic gloves.

System Components

1. System Head with UV Chamber
2. UV Ballast
3. Pressure Gauges x 2
4. Filter Housings x 2
5. Pleated Sediment Filter
6. Triple Purpose Filter with Anti-Rust Media
7. UV 254NM Wavelength Lamp
8. UV Quartz Sleeve
9. Filter Housing Wrench
10. Installation Hardware

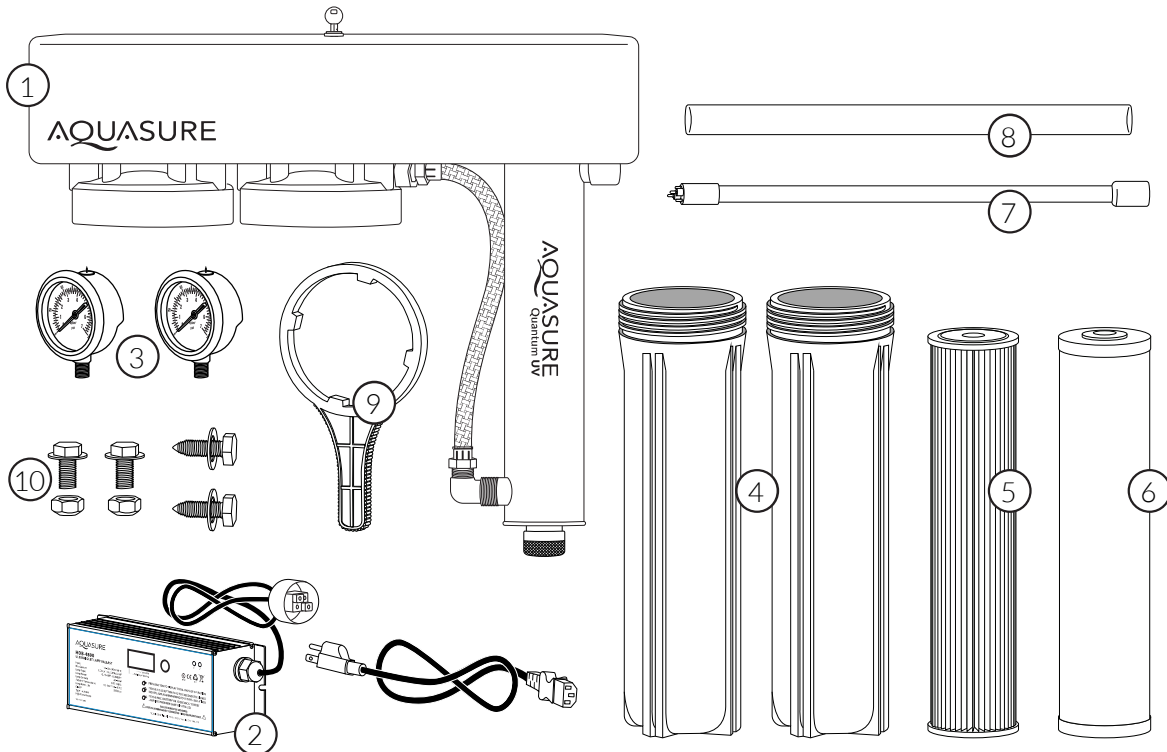

INSTALLATION DIAGRAM

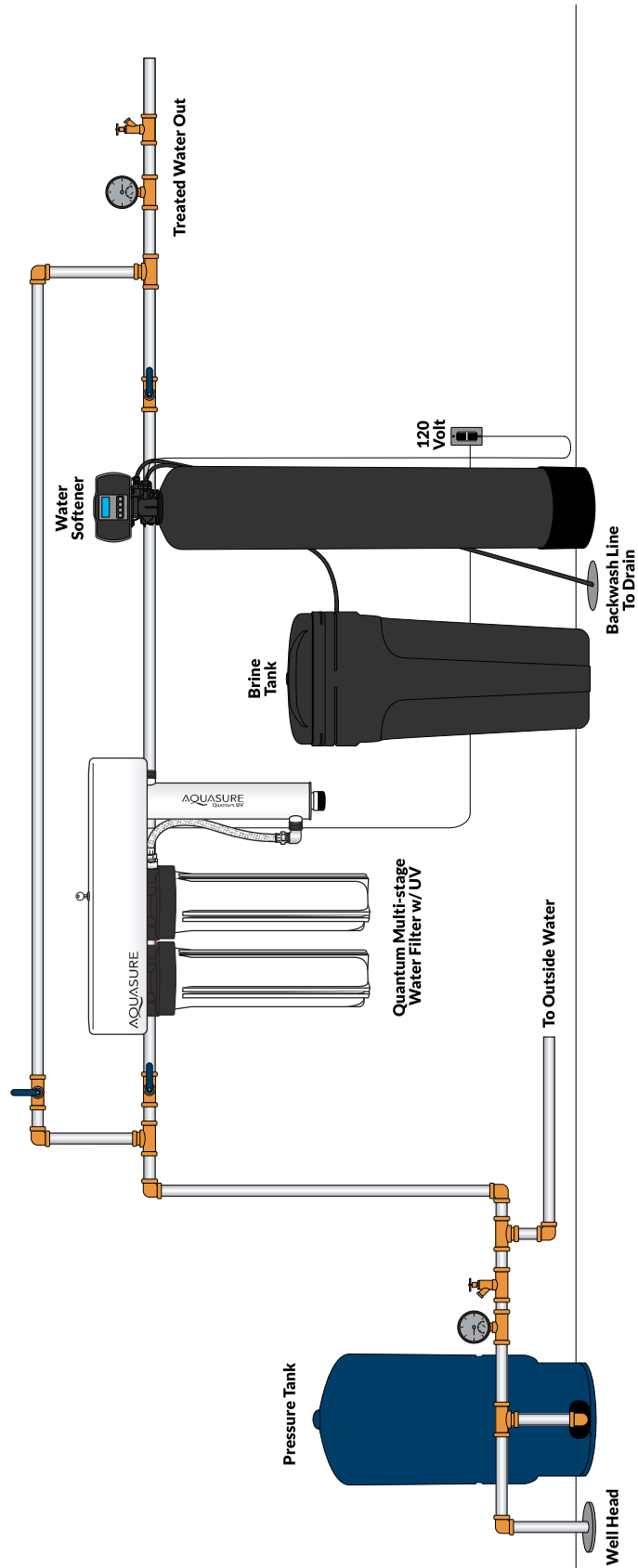













Note: If water hardness exceeds 7 GPG a water softener placed BEFORE the Quantum UV system is recommended.

SAFETY INSTRUCTIONS



WARNING - To guard against injury, basic safety precautions should be observed.

Read and follow all safety instructions.

1.  **CAUTION** - Disconnect power before servicing.
2.   **DANGER** - To avoid possible electric shock, special care should be taken since water is present near electrical equipment. Unless a situation is encountered that is explicitly addressed by the provided maintenance and troubleshooting sections, do not attempt repairs yourself, refer to an authorized service technician.
3. Carefully examine the disinfection system after installation. It should not be plugged in if there is water on parts not intended to be wet.
4.   Do not operate the disinfection system if it has a damaged cord or plug, if it is malfunctioning or if it is dropped or damaged in any manner.
5.   Always disconnect water flow and unplug the disinfection system before performing cleaning or maintenance activities. Never yank the cord to remove from an outlet; grasp the wall plug and pull to disconnect.
6.   Do not use this disinfection system for other than intended use (potable water applications). The use of attachments not recommended or sold by the manufacturer/distributor may cause an unsafe condition.
7.  Intended for indoor use only. Do not install this disinfection system where it will be exposed to the weather or to temperatures below freezing. Do not store this disinfection system where it will be exposed to the weather. Do not store this disinfection system where it will be exposed to temperatures below freezing unless all water has been drained from it and the water supply has been disconnected.
8.  Read and observe all the important notices and warnings on the water disinfection system.
9.   If an extension cord is necessary, a cord with a proper rating should be used. A cord rated for less Amperes or Watts than the disinfection system rating may overheat. Care should be taken to arrange the cord so that it will not be ripped over or pulled.



WARNING: The UV light given off by this unit can cause serious burns to unprotected eyes and skin. Never look directly at an illuminated UV lamp. When performing any work on the UV disinfection system always unplug the unit first. Never operate the UV system while the UV lamp is outside of the UV chamber.

Note: The UV lamp inside of the disinfection system is rated at an effective life of approximately 9000 hours. To ensure continuous protection, replace the UV lamp annually.

OPERATION PARAMETER

IMPORTANT: The following conditions for feed water supply must be met or warranty will be void and the manufacturer assumes no responsibility for damage to system or property.

1. **Water Temperature Parameter**

The system **MUST NOT** be installed in an area where it is exposed to direct sunlight and must be protected against freezing and extreme heat.

- Maximum: 100° F (37.8° C)
- Minimum: 32° F (0° C)

2. **Water Pressure Parameter**

The maximum allowable inlet water pressure is 125 psi. If daytime pressure is over 80 psi, night time pressure may exceed the maximum allowed water pressure. Use a pressure reducing valve (PRV) to reduce the pressure if needed.

- Maximum: 125 PSI (8.78 kg/cm²)
- Minimum: 25 PSI (1.75 kg/cm²)

3. **Water condition tolerance**

Water passed through the unit must fall within the following parameters:

- a) Iron: <0.3 ppm (0.3 mg/L)
- b) Hardness*: <7 ppm (120 mg/L)
- c) Turbidity: < 1 NTU
- d) Manganese: < 0.05 ppm (0.05 mg/L)
- e) Tannins: < 0.1 ppm (0.1 mg/L)
- f) UV Transmittance: > 75% (call factory for recommendations on applications where UVT < 75%)

* Where total hardness is more than 7 gpg, the water should be softened.

SYSTEM INSTALLATION

STEP 1: Shutting the water supply

1. Shut off the main water supply valve. Locate the main water supply valve of the house and turn off completely by turning the shut-off handle clockwise. If the main water supply valve fails to shut off the water completely during the test, we recommend contacting your local plumber to fix the valve before begin installing the system.
2. Test to see if the water is completely shut off by turning on the closest faucet in the cold water position. If the cold water cannot be shut off, please contact your local plumber to fix the valve before beginning system installation.

STEP 2: Mounting the system

1. Prep and survey the mounting location.

IMPORTANT: Please consider the mounting location and installation method before proceeding. Failure to securely fasten the system can result in damage to the system and plumbing.

IMPORTANT: This system requires maintenance and replacement of the UV lamp and filters. Install the system in an area that has clearance above and below the system for removing the UV lamp and filters. Ideally, the system should have lamp + 12" from the top of the system housing.

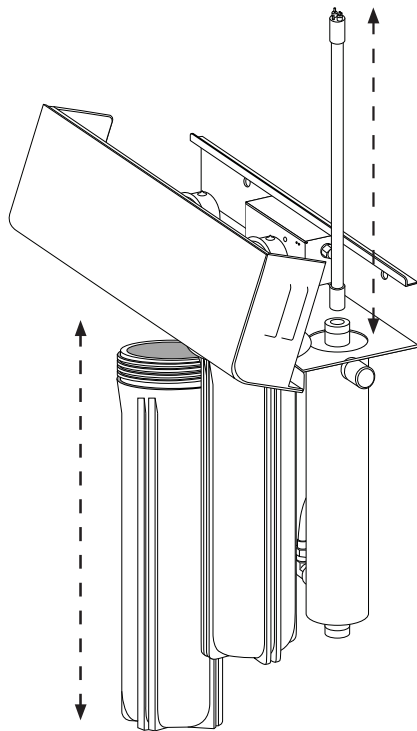

Note: System mounting location requires clearance above and below the system. Clearance below the system for removal and replacement of the pleated sediment filter and SPX filter cartridges. Clearance above the system is needed for replacement of the UV lamp.

Failure to provide adequate clearance could result in damage and/or the need to uninstall the system with each maintenance interval.

SYSTEM INSTALLATION

- Fasten the system to the mounting location using the provided bolts or fasteners specific to your installation method.

NOTE: The system bracket features mounting holes that are 16" apart for mounting to common home wall studs.

IMPORTANT: Use a leveling tool to make sure the system is installed at an angle.

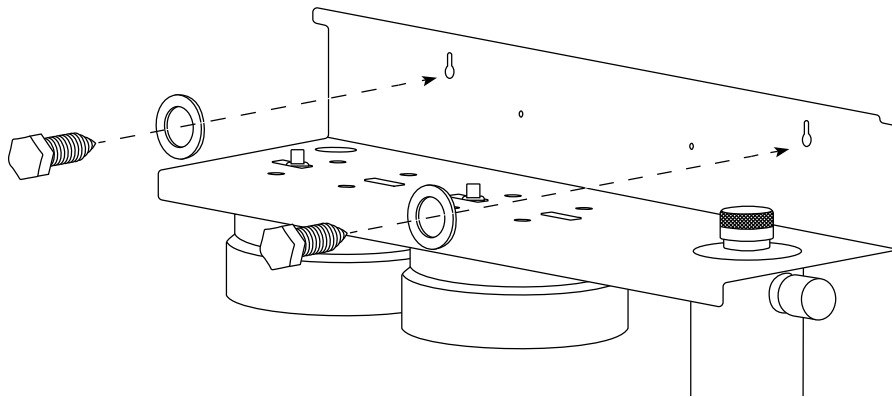

- Begin to attach the plumbing lines once the system is secured on the mounting surface.

NOTE: The system is equipped with 3/4" and 1" NPT connections. It is recommended that these connections are made using 6-10 wraps of plumber's tape.

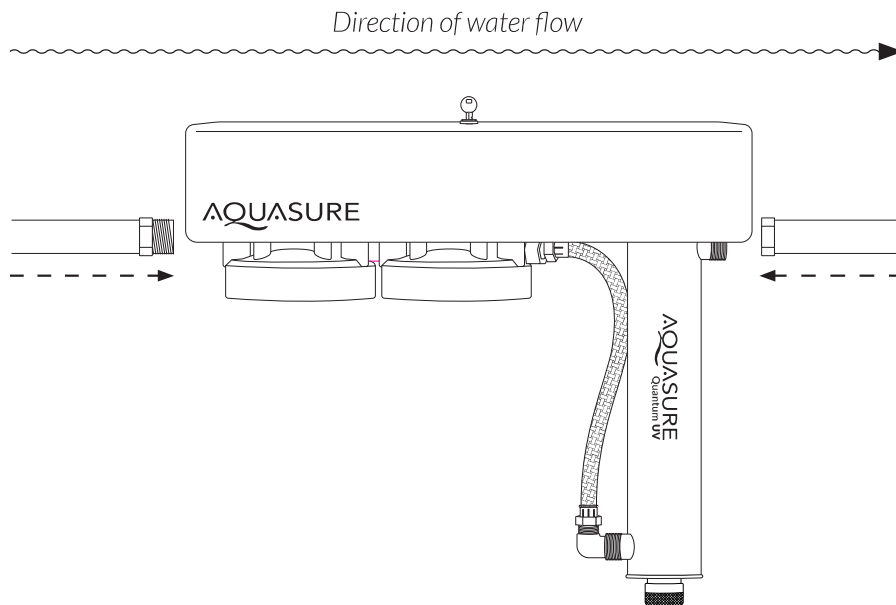

SYSTEM INSTALLATION

STEP 3: Installing the filters

1. Unwrap the filter cartridges and place them inside the housings.

IMPORTANT: Make sure the filters are centered and directly above the stand pipe that is located inside the housing at the base.

IMPORTANT: The pleated sediment filter should be placed as the first point of contact for water entering the system.

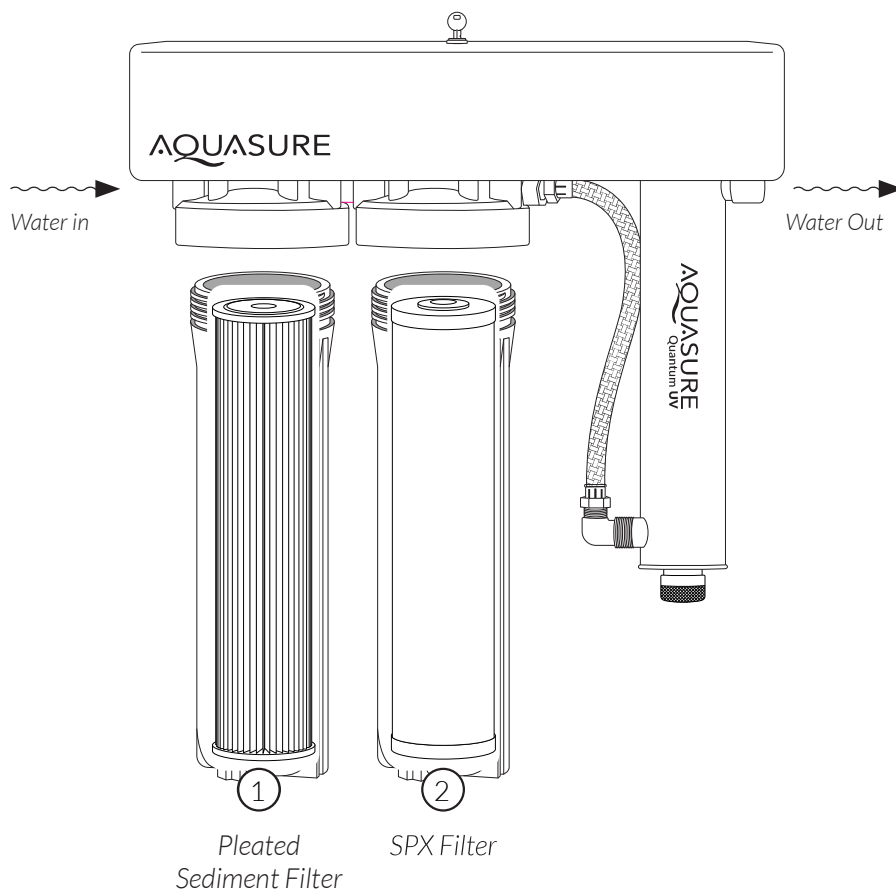

2. Screw on the housings with the filter inside by hand tightening to the filter housing cap counterclockwise. Proceed to use the filter housing wrench to secure the housings to the system. Make sure the o-ring is inside the housing. Do not overtighten the housings.

SYSTEM INSTALLATION

STEP 4: Installing the UV sleeve and UV lamp

IMPORTANT: During the assembly and handling of the quartz sleeve and UV lamp it is recommended to wear plastic gloves. DO NOT touch the quartz sleeve or UV lamp with bare hands. Fingerprints can reduce the performance of the UV lamp.

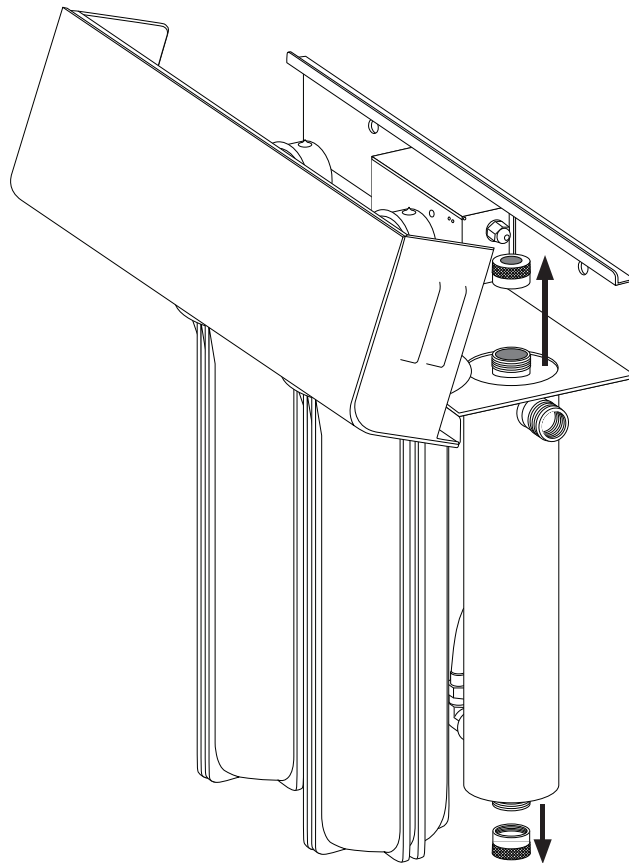

1. Locate and unscrew the top and bottom end cap for the UV chamber.

SYSTEM INSTALLATION

2. Locate and remove quartz sleeve and UV lamp from the packaging. If necessary, wipe all fingerprints from quartz sleeve and lamp with isopropyl alcohol and a dry cotton cloth or paper towel.
3. Slowly and carefully lower the quartz sleeve into the chamber.

IMPORTANT: The quartz sleeve and UV lamp are fragile and should be handled with care. Avoid excessive movement while inserting into the UV chamber to avoid contact with the inner surface.

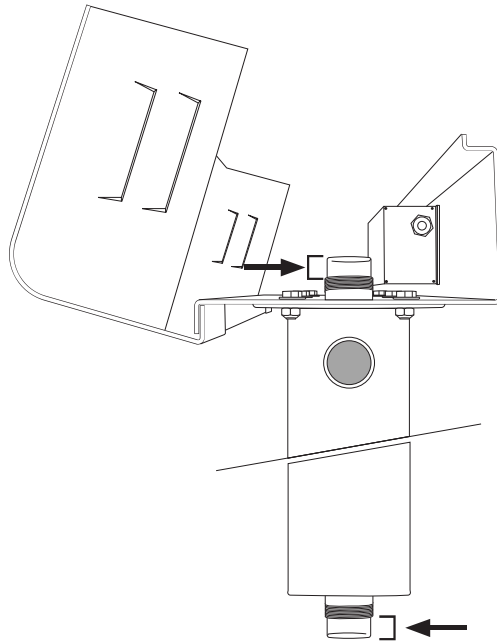

4. Position the quartz sleeve in the chamber allowing equal amounts of the sleeve exposed on the top and the bottom.

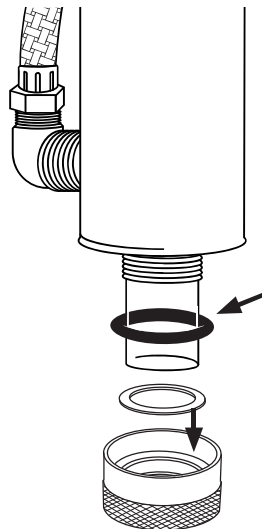

SYSTEM INSTALLATION

5. Begin assembly the bottom end cap components by inserting and seating the white pressure seal into the innermost position of the bottom end cap. Gently roll on the black o-ring over the end of the quartz sleeve.
6. Install the bottom end cap.

IMPORTANT: Hand tighten the end cap onto the UV chamber. Overtightening or tightening with the use of tools could result in damage to the quartz sleeve.

Top End Cap

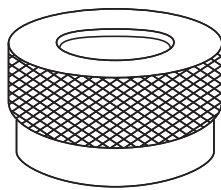

Bottom End Cap

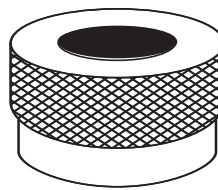

NOTE: The bottom end cap does not have an opening. The top end cap has an opening for the UV lamp to be inserted.

7. Repeat the assembly instructions for the top of the UV chamber by inserting the white pressure seal into the innermost position of the top end cap, and gently rolling the black o-ring over the end of the quartz sleeve.
8. Install the top end cap.
9. Locate the UV lamp and connect the ballast plug to the lamp's electrical prongs. Make sure the connectors are fully seated on to the prongs.

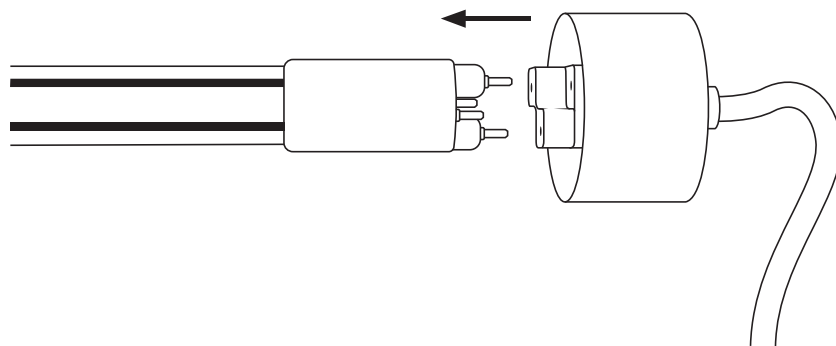

SYSTEM INSTALLATION

IMPORTANT: DO NOT TURN ON THE SYSTEM at this time and do not plug into a wall outlet. Never expose or look at the UV lamp that is powered on. Doing so can cause damage or loss of vision.

IMPORTANT: Handle the UV lamp gently to avoid damage or breaking the glass lamp or quartz sleeve.

10. With the ballast plug connect to the UV lamp **slowly** and carefully insert the UV lamp into the top end cap and into the quartz sleeve.

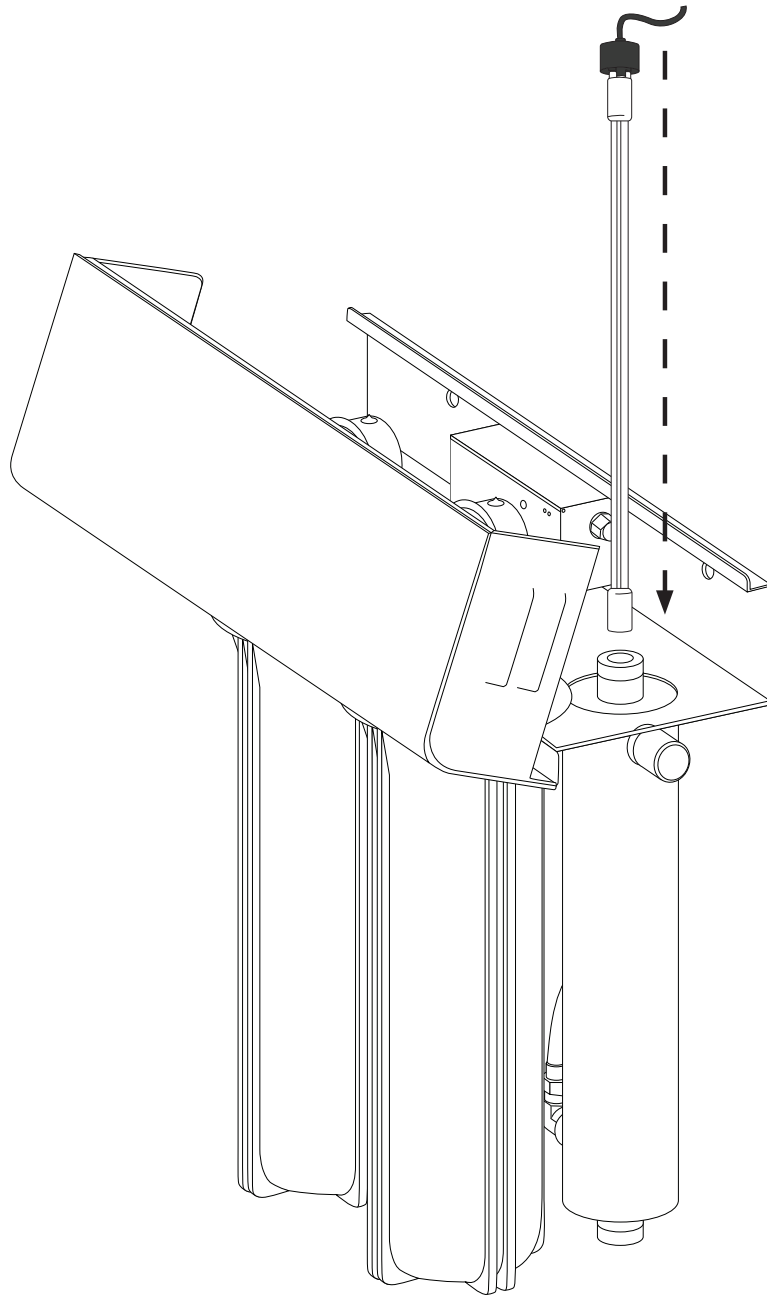

SYSTEM INSTALLATION

IMPORTANT: The UV lamp is fragile and should be handled with care. Slowly lower the UV lamp into the end cap and into the quartz sleeve. Prevent the glass components from making contact with each other and preventing damage.

11. Attach the ballast plug sleeve over the end cap. Ensure that it is fully seated to avoid the lamp from disconnecting.
12. Complete the installation by coiling the ballast wires neatly so that the system housing can fully closed. Lock the system with the provided key.

STEP 5: Flushing and testing the plumbing lines

WARNING: If the system is leaking turn the unit to the bypass position and shut off the main water supply before assessing the leak.

IMPORTANT: Flushing the system lines is necessary to ensure that all plumbing work has been done correctly, that there is no debris or air trapped in the piping, and that there are no leaks.

1. Locate the nearest faucet and remove the aerator (faucet screen) if there is any. Turn the cold water position on at the nearest faucet and slowly turn on the main water supply. Let the water run for a few minutes or until the system is free of any air or foreign material.
2. Make sure there are no leaks in the plumbing system before proceeding and shut off the nearest faucet when water runs clear. (Approximately 5 to 10 minutes)

STEP 6: System startup

1. Plug the AC adapter into a nearby wall outlet.
2. A LED indicator on the ballast should start to glow green indicating that the lamp is turned on and the system is in operation.

WARNING: If the LED indicator on the ballast is not showing any color, check the wall outlet to make sure it has power. Make sure to unplug the power supply anytime if removal of UV lamp is required.

CONGRATULATIONS!

Your system is ready to use. Please document the system installation date and replace the UV lamp in the suggested replacement time.

Be sure to register your system within 60 days of purchase. Scan the QR code below or go to aquasureusa.com/warranty to register your system.

Scan to register your system



REPLACING YOUR FILTERS & UV COMPONENTS

SUBSCRIBE AND SAVE

Never worry again when it's time to replace your filters.

Save time and money when replacing your Aquasure Quantum UV Filters or UV components with Subscribe and Save.

Get 25% off your first order and then 10% each order after that.

Signing up is easy...

1. Scan the QR code below
OR go to
aquasureusa.com/quantum
2. Select your replacement filters
3. Choose when you want to receive your new filters

That's it!

Cancel or change your delivery frequency at any time.

Scan the QR code to order Aquasure certified replacement filters



MAINTENANCE

Quartz Sleeve Replacement And/Or Cleaning:

IMPORTANT: If the system is put on a temporary hold, bypassed, removed, or if it becomes contaminated after the disinfection system, it will be necessary to shock the system with household bleach for a full 20 minutes before resuming use of the water.

If the water contains any hardness minerals (calcium or magnesium), iron or manganese, the quartz sleeve will require periodic cleaning:

1. Disconnect the power supply for the UV lamp. Shut off water supply and drain all lines.
2. Pull the UV lamp out of the chamber and place it on top of a microfiber cloth. Make sure to wear a glove and avoid contacting the lamp itself as much as possible.
3. Drain the UV chamber (use a small bucket under the unit to prevent a spill), using drain port provided.
4. Remove nuts from chamber, checking for the free floating spring inside sleeve at the opposite end to the lamp connection (do not allow quartz sleeve to fall).
5. Carefully remove O-rings from the quartz sleeve. As the O-ring may tend to adhere to the quartz sleeve, it is recommended to replace the o-rings annually.
6. Clean the quartz sleeve with a cloth soaked in CLR, vinegar or some other mild acid and then rinse avoiding the introduction of any water to the inside of the sleeve.
7. Re-assemble the system by following the instruction page 13.
8. Reconnect system to power source.

UV Lamp Replacement

1. Disconnect the power
2. Shut off water supply and drain all lines.
3. Pull the UV lamp off of the chamber while it is still connected to the ballast line.
4. Disconnect the old UV lamp from the ballast.
5. Connect the ballast plug to the new UV lamp electrical prongs.
6. Reinsert the lamp back into the chamber carefully.
7. Turn on the water supply and check for leaks.
8. Reconnect system to power source.

MAINTENANCE

Sediment & SPX (Stage 1 & 2) Filter Maintenance

Maintenance and/or replacement of the stage 1 and stage 2 filters is essential for optimum system performance.

Depending on your water quality, it is recommended that the sediment filter (stage 1) and the SPX filter (stage 2) be replaced every 6 months. This recommended time period should begin from first use of the system.

STEP 1: Shutting of the water supply

1. Turn off the main water supply.
2. Turn on the nearest faucet to release and excess water and pressure that is built up inside the pipe.

STEP 2: Removing the filter housing

1. Turn off the main water supply.
2. Turn on the nearest faucet to release and excess water and pressure that is built up inside the pipe.
3. Discard the old filter and clean the inside of the housing and cap with warm water.

CAUTION: Do not use any chemical to wash the housing.

STEP 3: Install the new filter

1. Unwrap the new filter and place it inside the housing and make sure the filter is centered on the stand pipe located inside the housing at the base.
2. Check the o-ring at the top of the housing for cracks or damage. Replace if it is damaged.
3. Install the housing to the corresponding head by turning it from clockwise. Tighten using the supplied filter housing wrench.

CAUTION: Do not overtighten the housing.

STEP 4: System startup

1. Turn on the main water supply valve.
2. Check for leaks.
3. Turn on the nearest faucet and let the water run for 10 minutes to release any trapped air bubbles or carbon fines from the SPX filter.

SYSTEM WARNING & TROUBLESHOOTING

Lamp Failure System

The audible alarm and indicator lights on the systems continuously monitor the lamp operation. If the lamp does not start at any time, the indicator red light will glow and audible alarm will sound. This alarm indicates the UV lamp is no longer operating and must be corrected. Please refer to Troubleshooting Guide for corrective procedures.

Ultraviolet Monitoring System

The ultraviolet system features a complete warning system for continuous water protection by constantly sensing the UV light operation. The system features a single LED indicator light, which will operate two distinct colors, GREEN and RED. When the UV output level changes, the warning system will operate in the following manner:

- GREEN** ● Indicates that the UV lamp is satisfactory and the unit is in good working order.
- RED** ● Indicates that the unit needs immediate attention, the audible alarm will automatically sound when the LED monitor light switches to red if the lamp has been in service for a year or more it should be replaced. The quartz sleeve and/or sensor probe may require cleaning. The alarm will continue until the sensor detects adequate UV intensity. When the lamp is replaced it is recommended to clean the quartz sleeve and sensor probe prior to returning the system to service.



THIS ADVANCED WARNING SYSTEM HAS BEEN INSTALLED TO PROVIDE YOU WITH THE OPTIMUM PRECAUTIONS TO ENSURE HIGH EFFICIENCY IN THE PROTECTION AGAINST MICROBIOLOGICAL CONTAMINATION IN YOUR WATER. DO NOT DISREGARD THE WARNING LIGHTS.

THE BEST WAY TO CHECK UV OPERATION IS TO HAVE THE WATER TESTED FOR BACTERIA BY A RECOGNIZED TESTING AGENCY ON A REGULAR BASIS.

SYSTEM WARNING & TROUBLESHOOTING

WARNING: When there is no flow, the water in the cell will become warm, as the UV disinfection system lamp is always on. To remedy this, run cold water tap anywhere in the house for a minute to flush out the warm water.

As the system requires time to reach its full operating capacity, please allow the disinfection system to operate 3-5 minutes prior to using the water from unit. In addition, to clear any air or debris from the system, open the faucet and allow water to run through the disinfection system for 2-3 minutes.

Troubleshooting Guide

CAUTION: When performing any work on the disinfection system unplug the unit first and never look directly at the burning UV lamp.		
SYMPTOM	POSSIBLE CAUSES	REMEDY
PRESSURE DROP	The sediment pre-filter is clogged	Replace filter cartridge with appropriate five micron cartridge. NOTE: Check source of water supply as fluctuations may occur in source pressure
HIGH BACTERIA COUNT	Quartz sleeve is stained or dirty	Clean sleeve with scale cleaner and eliminate source staining problem
	The UV lamp is spent	Replace UV lamp
	Change in feedwater quality	Have the source water tested to ensure it is still within the allowable parameters for use with this unit
	Contamination after disinfection system	It is imperative that the effluent water stream be shocked with chlorine after the water leaves the disinfection system the disinfection system must have a bacteria free distribution system to work effectively
WARM PRODUCT WATER	Common problem caused by infrequent use	Run water
WARM WATER APPEARS "MILKY"	Caused by air in the water lines	Run water until air is purged
UNIT LEAKING WATER	Problem with O-ring seals (on gland nuts and/or sensor probe on monitored units)	Ensure the O-ring is in place, check for cuts or abrasions, clean O-ring, moisten with water and re-install, replace if necessary
	Condensation on reactor chamber caused by excessive humidity	Check location of disinfection system and control humidity
	Inadequate inlet/outlet port connections	Check thread connections, re-seal with Teflon tape and re-tighten

SYSTEM WARNING & TROUBLESHOOTING

SYSTEM STATUS			REMARKS
LAMP STATUS (GREEN LED)	AUDIBLE ALARM	UV LAMP	
ON	OFF	ON	Correct operating conditions, unit is functioning properly
OFF	ON	OFF	The UV lamp is spent, requires replacement lamp. UV lamp not connected to power source. Check connection and reconnect lamp. Ballast has switched off. To reset ballast remove power to unit by disconnecting power cord from electrical plug for a minimum of 30 seconds then reapply power. LED indicator burnt out or wire lead broken. Replace LED assembly.
OFF	OFF	ON	LED indicator burnt out or wire lead broken. Replace LED assembly.

WATER CHEMISTRY

Water quality is extremely important for the optimum performance of your UV system. The following levels are recommended for installation:

- Iron: <0.3 ppm (0.3 mg/L)
- Hardness *: < 7 gpg (120 mg/L)
- Turbidity: < 1 NTU
- Manganese: < 0.05 ppm (0.05 mg/L)
- Tannins: < 0.1 ppm (0.1 mg/L)
- UV Transmittance: > 75%
(Call factory for recommendations on applications where UVT < 75%)

* Where total hardness is more than 7 gpg, the UV unit should operate efficiently provided the quartz sleeve is cleaned periodically. If total hardness is over 7 gpg, the water should be softened.

If your water chemistry contains levels in excess of those mentioned above, proper pre-treatment is recommended to correct these water problems prior to the installation of your UV disinfection system. These water quality parameters can be tested by your local dealer, or by most private analytical laboratories. Proper pre-treatment is essential for the UV disinfection system to operate as intended.

USING THE SYSTEM GAUGES

The system gauges are useful for monitoring the pressure levels of your water and also can be used for identifying a drop in pressure to one or both of the filters located in stages one and two.

To best identify if a drop in water pressure is occurring, please record the pressure levels when the filters and system are newly installed.

This will provide a marker for ideal water pressure. Using the new filters as a guide for determining what your pressure levels should be.

Once you have used the system for an extended period of time the filters may start to collect excessive contaminants in the water. This will result as a drop in water pressure.

Record your water pressure levels when the filters are new.

When this level declines by 15 PSI, please inspect the filter cartridges.

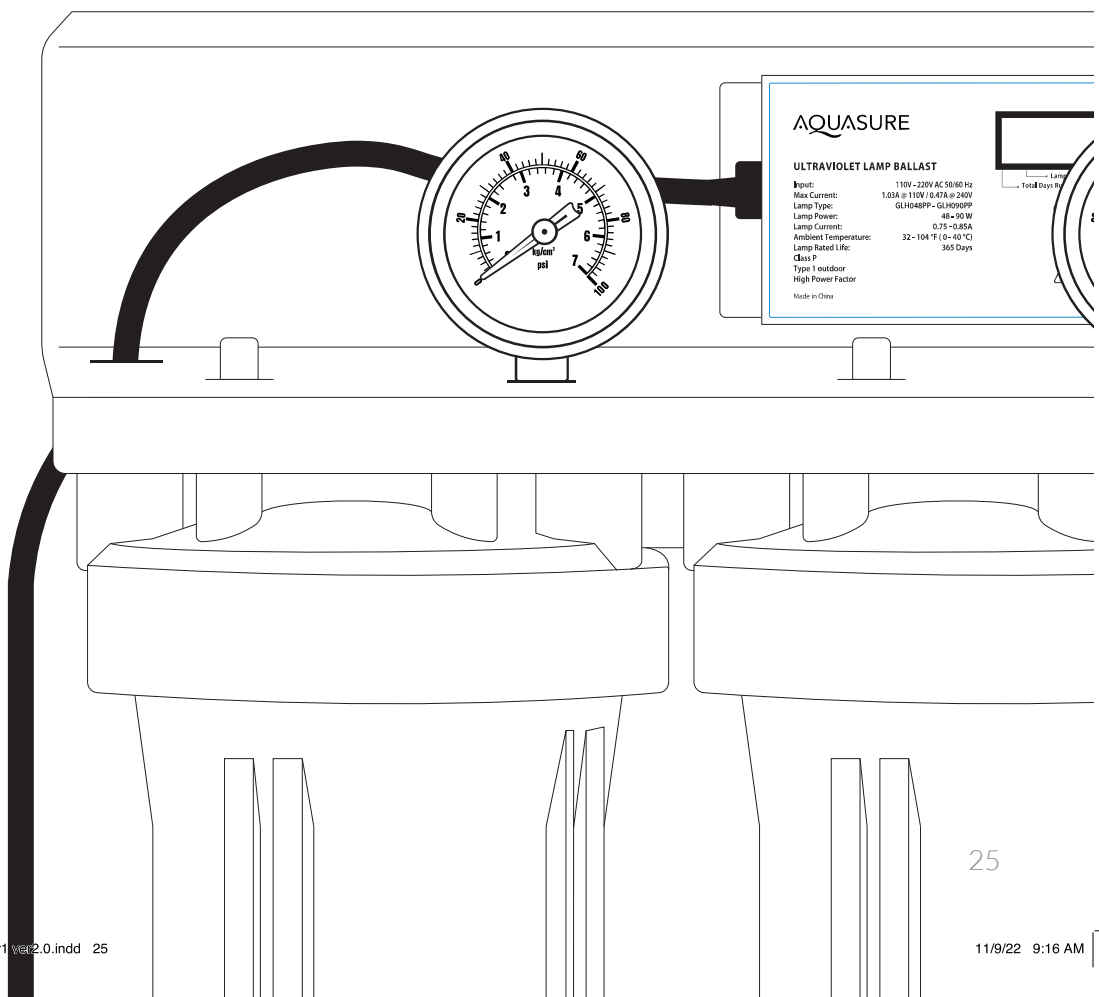

WARRANTY

AQUASURE™ warrants the Quantum Ultraviolet (UV) Purifier system's hardware and electrical systems to be free from defects in material and workmanship for a period of one (1) year from the date of purchase by the original owner on a pro-rated basis. With an additional two (2) years of coverage for products registered with Aquasure™ within 60 days of the original purchase date.

AQUASURE™ warrants the ultraviolet lamps and sensor probes to be free from defects in material and workmanship for a period of one (1) year and the reactor chamber for a period of one (1) year. The warrantor will at its option and expense, either repair or replace such units subject to the following conditions, exceptions, and exclusions.

Conditions, Exceptions, And Exclusions

The foregoing limited Warranty is subject to the following terms and conditions:

1. Water passed through the unit must fall within the following parameters:
 - a) Iron: <0.3 ppm (0.3 mg/L)
 - b) Hardness*: <7 ppm (120 mg/L)
 - c) Turbidity: < 1 NTU
 - d) Manganese: < 0.05 ppm (0.05 mg/L)
 - e) Tannins: < 0.1 ppm (0.1 mg/L)
 - f) UV Transmittance: > 75% (call factory for recommendations on applications where UVT < 75%)

* Where total hardness is more than 7 gpg, the water should be softened.

Warranty will be void, if the proper steps are not taken to ensure that these impurities are not present.

2. This limited Warranty shall not apply to any unit which has been repaired or altered by anyone other than the Warrantor or by a person authorized by the Warrantor, nor to any units which have been subject to misuse, neglect, or accident. Do not remove any of the products labels. Warranty will be deemed null and void if any of the products original labels are removed.
3. This limited Warranty runs exclusively to the original Consumer and with respect to the original installation only.
4. WARRANTOR SHALL NOT BE LIABLE FOR ANY INCIDENTAL OR CONSEQUENTIAL DAMAGES.
5. This limited Warranty excludes the cost of labor in removing any defective unit or installing any replacement unit. This limited Warranty applies only to a unit when returned to the Warrantor at the owner's expense and in accordance with shipping instructions received from the Warrantor.



AquasureUSA.com | 800.661.0680 | support@aquasureusa.com