



## Installation & Assembly Instructions

### 990 | 990-S DuraHook Locking Pegboard System

**Read all instructions completely before installing. Should you have any questions about your installation, please call Customer Service at 440-248-5480**

Tools needed for this installation (not supplied with kit): Drill, Phillips Screwdriver, Tape Measure, Level

#### Parts Listing

Part Number	Quantity	Description
990   990-S	2	Polypropylene Pegboard 18" x 22" x 1/8" thick
	24	Assortment DuraHook Locking Pegboard Hooks
	32	Lock Screws for hooks (packaged separately)
	2	Hanging Plastic Bins
	2	BinClips for Hanging Plastic Bins
	18	#12-2" long wood screws
	18	#12 plastic wall anchors
	18	Metal wall mounts/spacers

**1. Wall Mounting Instructions:** Polypropylene pegboards can be mounted to walls in separate locations, side by side horizontally or above one another vertically.

- A. Determine the location or locations where you want to mount your new storage system.
- B. Determine if you want to mount boards (a) side by side horizontally, (b) above or below one another, or (c) in a different location.
- C. Using one sheet of the Polypropylene Pegboard (DuraBoard®) determine the location and height you wish to mount your DuraHook storage system.
- D. (Using diagram 1-1) Hold one sheet of pegboard flat against the wall surface, use level to make sure board is level and square.
- E. (Using diagram 1-1) While still holding pegboard flat against wall level and using a pencil, make a circular trace inside of all (9) hole locations using diagram 1-1. (If planning to mount boards in totally separate locations go to step (H))
- F. If you're planning to mount the second pegboard directly to the side or above or below the first: Hold the first pegboard flat against the wall while making sure all 9 traced holes are still aligned with appropriate holes in pegboard. Using a pencil, trace the outer edge of the board you're planning to mount the second board against.
- G. If mounting side by side or above or below one another: use the second board in your kit, align outer edge with pencil mark created in step (F). Do not cover up pencil mark with board. Mark hole locations as listed in step (E).

## Installation & Assembly Instructions

- H. Using an electric drill with 5/16" drill bit, drill hole locations marked in step (E). Should any hole location fall in line with a wood wall stud, it will not be necessary to pre-drill.
- I. Gently insert plastic wall anchors into holes pre-drilled in step (H.) (You will not need to install plastic wall anchors where a wall stud is located or when installing on solid wood surfaces. Wall anchors will be required for all concrete walls.
- J. Using your first pegboard sheet insert all nine (9) #12- 2" wood screws through the pegboard holes specified in diagram 1-2.
- K. Slip steel wall spacers over each screw as shown in diagram 1-3.
- L. Insert each screw into its pre-installed wall anchor or assigned hole location. Using a #2 Phillips head screwdriver and starting from one of the top corner hole locations insert screws halfway. (This will leave you enough play/flexibility to insert each screw properly.)
- M. Once all 9 screws have been installed halfway, tighten all screws down to a point that all spacers are snug against wall surface. (Always avoid over-tightening of any screw.)

Repeat Instructions for installation of second pegboard panel

### 2. **Hook Installation:** (Using a handheld Phillips head screwdriver)

- 1. Insert hook's panel engaging tab through first hole in pegboard.
- 2. Align hook's screw hole with second hole in pegboard.
- 3. Secure in place using small Phillips head screws and hand held screwdriver (non-powered.) Do not use 2" long wood screws. Do not over tighten screws used for mounting hooks.

Note: All hooks can be mounted horizontally or vertically to store items and can be combined with one another to create storage solutions for heavier and odd shaped items and tools. For BinClip™ and Hanging Bin mounting – insert hooks panel engaging tab facing up.



Diagram 1-1

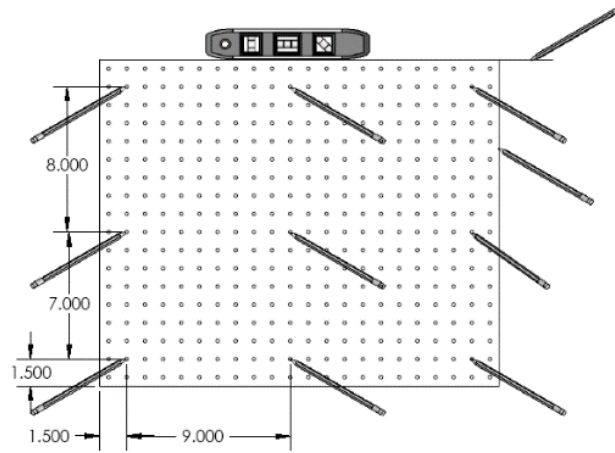

Diagram 1-2

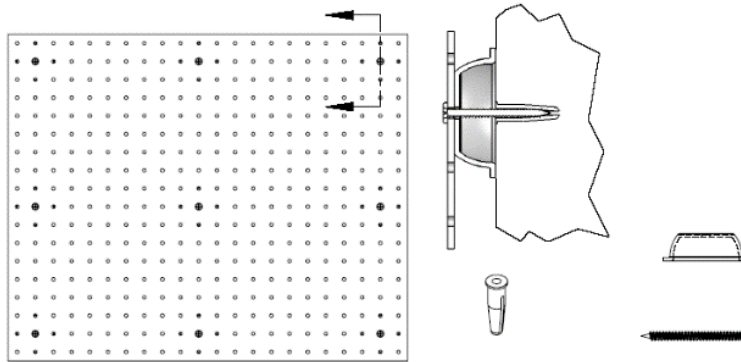

Diagram 1-3

**LIMITED LIFETIME WARRANTY:** Triton Global Products are backed by a Limited Lifetime Warranty to the original owner that our products are free from defects in material and workmanship. If a product is defective when used as intended under normal conditions, Triton will replace the product, send a replacement part or issue a refund (at our option) when the consumer provides the original proof of purchase along with a full description of the defect, to: Triton Global Products 30700 -D Carter Street Solon OH 44139 All of our steel products have been engineered to last a lifetime.

**EXCLUSIONS TO LIMITED LIFETIME WARRANTY:**

- Excludes Normal Wear and Tear.
- Excludes Cosmetics and Aesthetics.
- Is Void if Products were improperly installed or used incorrectly (i.e., Not per Included Instructions).
- Excludes Plastic and any other Non-Metal based Products.
- Limited Lifetime Warranty is Non-Transferable and only applies to the original purchaser.
- Original Proof of Purchase is required for all warranty claims.