

# Plug-in Dimmer with Wi-Fi Technology

decora smart™



## APPLICATIONS

Schedule or dim your plug-in lamps from anywhere. Control connected loads and lights using the free My Leviton app for iOS and Android, no hub required. Simplify control of the residence – schedule lights and connected loads to turn on/off at specific times or based on sunrise/sunset, easily group smart devices into rooms, and create scenes to activate multiple lights at once. Integrate with IFTTT, utilize auto-shutoff feature as a countdown timer in closets, hallways and bathrooms; plus engage home vs. away to enact randomization of lighting control, providing a lived-in appearance.

Customize your experience with adjustable fade rates, maximum/minimum illumination levels, and more if desired. Supports LED and CFL technologies up to 100 Watts along with support for legacy incandescent lighting loads up to 300 Watts. Reduce energy consumption, provide dramatic scene transitions, and utilize the wireless affordable plug-in for table and floor lamps.

## AMAZON ALEXA VOICE CONTROL

Compatible with all products that support Amazon Alexa providing voice control of the load: “Alexa, dim living room lights to 25%”. Alexa devices (including Echo, Dot, and Tap) sold separately.

## Leviton Manufacturing Co., Inc. Global Headquarters

201 N. Service Rd. Melville, NY 11747-3138 Tech Line: 1-800-824-3005 Fax: 1-800-832-9538

## Leviton Manufacturing Co., Inc. Energy Management, Controls and Automation.

4330 Michoud Blvd., New Orleans, LA, 70129 Tel: 1-504-736-9810 Fax: 1-504-253-2954

Visit our Website at: [www.leviton.com/decorasmart](http://www.leviton.com/decorasmart)

©2017 Leviton Manufacturing Co., Inc. All rights reserved. Subject to change without notice.

## GOOGLE ASSISTANT VOICE CONTROL

“Ok Google, turn [My Leviton device name] On”. Works with the Google Assistant. Google Home is a voice enabled speaker powered by the Google Assistant. Easily control smart devices around the home. (Google Assistant devices sold separately).

## LOW-WATTAGE LED LOADS

The new lighting control accessories are engineered to function with extremely sensitive, low-wattage light sources, such as a single LED bulb in a hallway or a strand of holiday lights, ensuring LEDs do not glow when off.

## BENEFITS

- Control your lights from anywhere using the free My Leviton app for iOS and Android, no hub required.
- Amazon Alexa products provide voice control: “Alexa, turn on living room lights”. (Echo, Tap, and Dot sold separately).
- Works with Google Assistant including Google Home for voice control. “Ok Google, set [My Leviton device name] to [1-100]%”
- Integrate with IFTTT for additional third-party functionality
- Simplify control of your home - schedule lights and connected loads to turn on/off at specific times or based on sunrise/sunset, easily group your smart devices into rooms, and create scenes to activate multiple lights at once.

## FEATURES

- Button for manual control and dimming
- Transient surge protection to IEC Level 4
- ESD protection to IEC 1000 4-2 Level 4 to protect against damage
- Green LED locator
- Provides polarized 300W-120VAC NEMA 5-15R receptacle
- Provides manual ON/OFF
- Provides ON/OFF scene and zone control compatibility
- 2-way status updates
- Protected memory maintains ON/OFF status of loads during minor power fluctuations

**DRAWING**

**DW3HL**

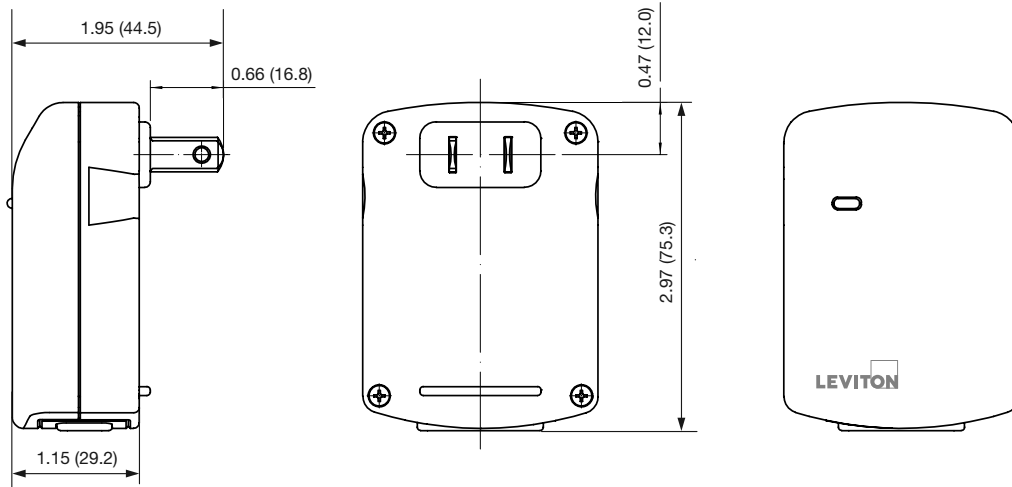

**RATINGS**

- Incandescent - 300W - 120VAC, 60Hz
- LED/CFL - 100W - 120VAC, 60Hz

**WARRANTY INFORMATION**

- Five-Year Limited Warranty

**AGENCY STANDARDS AND COMPLIANCE**

- Complies with UL 1472
- CSA Certified (File #003413)
- NOM-ANCE Certified
- Wi-Fi CERTIFIED™
- Complies with FCC Part 15, Class B

**ORDERING INFORMATION**

DESCRIPTION	CAT. NO.
Plug-in Dimmer with Wi-Fi Technology - 120VAC 60Hz Incandescent, 300W, 2.5A LED/CFL; 100W	DW3HL-1BW

**Leviton Manufacturing Co., Inc. Global Headquarters**

201 N. Service Rd. Melville, NY 11747-3138 Tech Line: 1-800-824-3005 Fax: 1-800-832-9538

**Leviton Manufacturing Co., Inc. Energy Management, Controls and Automation.**

4330 Michoud Blvd., New Orleans, LA, 70129 Tel: 1-504-736-9810 Fax: 1-504-253-2954

Visit our Website at: [www.leviton.com/decorasmart](http://www.leviton.com/decorasmart)

©2017 Leviton Manufacturing Co., Inc. All rights reserved. Subject to change without notice.

SAT-10114  
REV JUL 2017