

Welcome to RibbonFlex Pro® LED Tape Lighting

Ultra thin and flexible, RibbonFlex Pro® white LED lighting is easy to install in straight, curved and irregular spaces – offering virtually limitless design and installation possibilities. Using high performance solid state lighting technology, light output, color accuracy and LED brightness are exceptional. Fully dimmable and designed to cast a seamless glow, RibbonFlex Pro creates warm and relaxing environments or delivers bright task lighting.

60 White LEDs per meter (18 LEDs per foot), model # RF3528060

Good, all-around solution for accent lighting and lower brightness task lighting.

- Over, under and inside cabinets, and in toe kick areas
- Indirect lighting for coves and tray ceilings
- Edge lighting under counters and shelving perimeters
- Use in displays and bookcases
- Creative lighting for objects and artwork

Please read these guidelines completely before installing.

RibbonFlex Pro LED tape is a new and exciting type of lighting. It is important to read these guidelines completely to understand how the product works, and how it can be configured, cut to size, connected, and installed so you can design your LED lighting layout.

Installing tape lighting is an easy DIY project, however, basic wiring skills such as stripping, splicing, extending, and connecting wires are required.

This product operates on low voltage 12V DC power. 12V DC power supplies are sold separately and are available in different wattages. Some are dimmable, some are not.

Visit armacostlighting.com for additional installation tips, ideas, and latest product information.

Cut to Size

Offers unlimited lighting design options for custom installations.



Connect with Ease

Use LED Snap Connectors to join strips and add power wires.

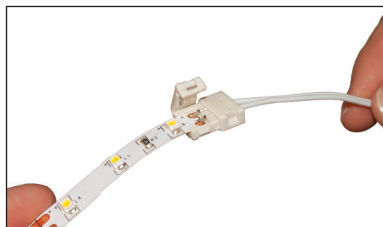

Peel and Stick

Simply remove 3M paper backing from LED tape lighting and stick in place.

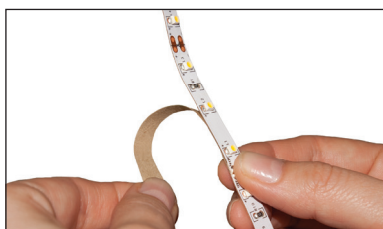

IMPORTANT

- Use only with low voltage 12V DC power source
- Do not stare directly into the LED lights when illuminated
- Do not power LED tape while coiled on reel
- Always observe polarity for 12V connections, positive (+) to positive and negative (-) to negative
- Do not install this product in areas that are susceptible to direct exposure to the elements
- Use only insulated staples, plastic ties, or wire support clips to secure cords and wires
- Route and secure wires so they will not be pinched or damaged
- For any wire runs inside of walls, use properly certified CL2 or better cabling
- Do not install Class 2 low voltage wiring in the same runs as AC main power. If AC and low voltage wires cross, keep them at 90-degree angles

All wiring must be in accordance with national and local electrical codes, low voltage Class 2 circuit. If you are unclear as to how to install and wire this product, contact a qualified professional.

Planning

RibbonFlex Pro LED lighting is designed for indirect lighting applications. The light from the LED tape is not to be seen directly by the eye. Every installation is unique and the illumination effects are personal preference. Installation location, wall colors, mounting angle, and the light's reflection off of walls, surfaces and objects will affect the final lighting appearance.

Installation considerations

- Where will you locate your power supply?
- How will you switch your LED lighting on and off?
- What is the best layout configuration for your installation?
- How will you run and conceal the wires to your LED tape lighting?



Temporarily mounting the LED light strip using painter's tape allows you to experiment with tape light positioning before permanent installation.

Important: Using painter's tape or masking tape, temporarily place the LED light strip into your desired mounting position. Power on the LEDs to make sure you are achieving the desired lighting effect before removing the 3M paper backing for final installation.

Optional Soldering of RibbonFlex Pro

Soldering is a fast and easy way to join wires and make splice connections. It is also the surest method for making extra reliable electrical connections.

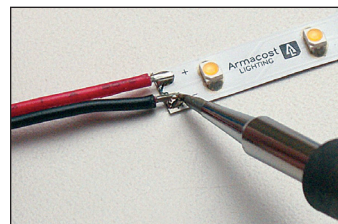

Wire Lead Connection

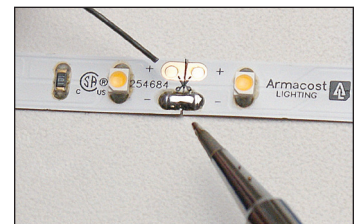

Splice Connection

To learn how to solder RibbonFlex Pro, visit armacostlighting.com/installation.

Note: Soldering connections is required for marine or RV applications due to vehicle movement and vibrations.

Power supply location and voltage drop

The power supply that provides 12V DC power to your LED tape lighting operates on 120V AC household current. The shorter the wire lead between the power supply and the LED tape lighting, the brighter the lights will be. If the lights farthest from the power supply appear dim, it is due to voltage drop.

Voltage drop only becomes undesirable if you notice the brightness in one area of your lighting is objectionably different than in another area. As a practical approach, test your lighting prior to final installation. Refer to the chart below for recommended lengths of power feed wires using 22 and 18 AWG wires.

Excessive voltage drop = reduced brightness and color accuracy

Shorter and/or thicker wires = higher brightness and color consistency

Longer LED tape = an increase in voltage drop

Recommended maximum length of 12V power wires from power supply to LED lighting			
22 AWG WIRE		18 AWG WIRE	
If your LED tape light length is:	Max wire length to tape light	If your LED tape light length is:	Max wire length to tape light
12 Feet	10 Feet	12 Feet	20 Feet
24 Feet	8 Feet	24 Feet	16 Feet
36 Feet	6 Feet	36 Feet	12 Feet
48 Feet	4 Feet	48 Feet	8 Feet

For an online voltage drop calculator, visit armacostlighting.com/installation.

Switching and dimming options

If you do not have a switched 120V AC outlet for your LED power supply, consider an optional Armacost Lighting wireless wall switch or an Armacost 12V LED dimmer switch with optional RF wireless designer-style touchpad.

Important: Do not use a standard AC wall dimmer with your power supply unless the power supply clearly states that it is dimmable with 120V AC dimmers.

For power supply options visit armacostlighting.com/power-supply.

TYPICAL CONNECTING AND SWITCHING OPTIONS

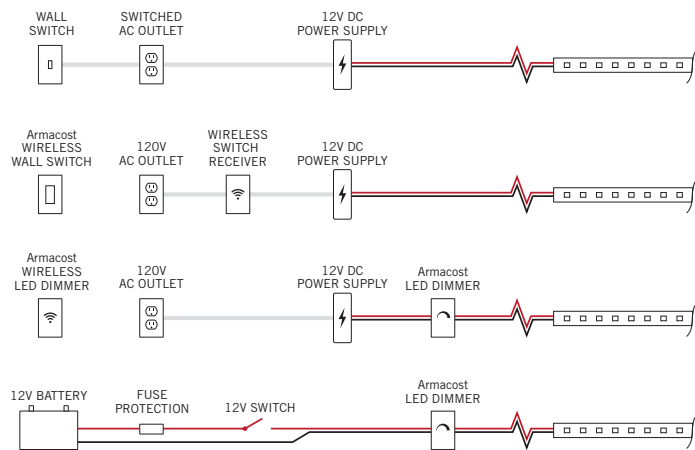

Interior RV and boat applications can be powered directly by 12V battery

Configuration options

RibbonFlex Pro offers endless connection options to fit virtually any installation imaginable. LED tape strips can be installed in series (strips connected or wired end-to-end) or in parallel (multiple legs of LED strips or series of strips wired directly to a single power supply).

LED tape lighting power requirements are based on several factors, including your configuration (Straight Run, Center Feed/Loop Back or Array), voltage drop, and the length limitations of the LED tape lighting.

TYPICAL CONFIGURATIONS

Straight Run

Only one end of the LED strip is powered. Multiple strips can be connected in a series for a continuous run. LEDs farther away from the power supply may appear dimmer due to voltage drop, especially if longer wires are used in between to connect strips.

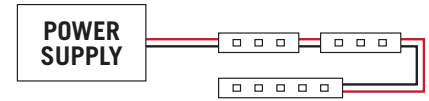

Center Feed / Loop Back

Either power two equal legs of tape lighting from the center or loop back and power both ends of the LED tape. These configurations will produce more consistent brightness and color over the length of the strip. A loop back is excellent for room perimeter tray ceiling or cove lighting.

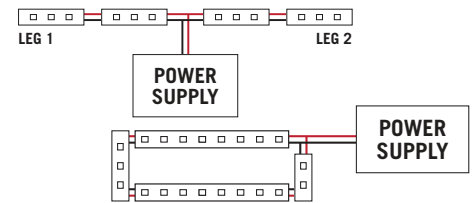

Array

An array uses two or more legs of various lengths wired to a power supply in a parallel connection. You will need to calculate total wattage used in an array to guard against overloading the power supply.

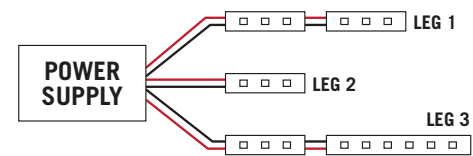

Choosing a power supply

Refer to the charts below for the recommended maximum lengths of LED tape lighting based on your configuration and choose a power supply rated greater than your needs – you cannot overpower LED tape lighting. The LED power requirements shown below are based on 100% full power brightness levels and do not represent every possible installation scenario.

Do not use a standard 120V AC wall dimmer with your power supply unless the power supply clearly states that it is dimmable with AC dimmers.

For power supply options visit armacostlighting.com/power-supply.

Maximum length of LED tape based on configuration type and power supply

Power Supply	Straight Run	Center Feed / Loop Back
6 Watt	3.3 ft (1.0m)	Not recommended
15 Watt	10.5 ft (3.2m)	9.0 ft (2.75m)
30 Watt	24.0 ft (7.3m)*	20.0 ft (6.0m)
60 Watt	24.0 ft (7.3m)*	48.0 ft (14.6m)

*Due to voltage drop, exceeding 24-foot lengths will cause LEDs farthest from the power supply to appear dimmer. It is okay to use a higher wattage power supply, however, it will not reduce the impact of voltage drop.

Array power supply calculation

Due to voltage drop, longer lengths of LED tape will use fewer watts per foot than shorter lengths. The total watts used in an array layout depend on the wattage requirement of each leg and overall voltage drop within your connection wires. A leg can be a single LED strip or series of strips connected end-to-end. Various legs are wired in parallel directly to the power supply.

Calculate the wattage for each leg by multiplying watts per foot by the length of LED lighting in the leg. Include only the lengths of LED tape in your calculation, not the connecting wires. Add each leg's wattage requirement together to determine the total watts needed to power your array and select a power supply that exceeds the total watts needed.

Length of leg (LED tape light only)	1 to 5 feet	6 to 11 feet	12 to 15 feet
Watts used per foot	1.8 watts/ft	1.6 watts/ft	1.4 watts/ft

Cutting, connecting and wiring

Warning: Do not connect LED tape to household 120V AC power. Only connect to low voltage 12V DC power.

Always maintain polarity when connecting LED tape lighting and low voltage power wires.

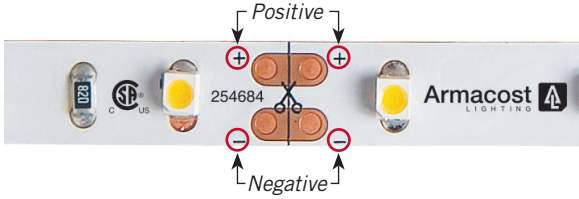

Be sure to connect positive wires to positive (+ to +), and negative wires to negative (- to -). Polarity is easily identified with + and - markings on LED tape as shown.

Cut with scissors

This tape light model can be cut every 3 LEDs, or about every 2".

- To use solderless LED Snap Connectors, cut the LED tape with scissors directly in the center of the copper pad as shown in position "A" below.
- You can also cut the tape at position "B," however, do not use Snap Connectors on these soldered tape light joints..
- You can also solder 12V power lead wires at these joints.

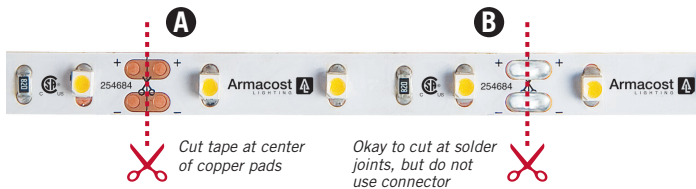

Wire Lead Snap Connectors

Wire Lead Snap Connectors are used for going around corners or, when cut in half, to create two power leads ("jumper" cables) for linking and extending power wires to LED tape lighting in other areas.

IMPORTANT: Always use the + / - indicators printed on the tape light to maintain polarity.

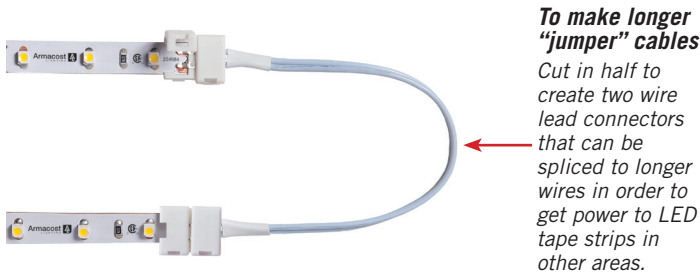

Bridging gaps and extending wires

To increase the length of wire between two LED strips, simply splice in the extra length of wire required, 18 AWG is generally recommended. Be sure to match polarity, + to +, - to -. Do not coil wire; shorter lengths and thicker wire will mean less voltage drop and higher brightness. For an online voltage drop calculator, visit armacostlighting.com/installation.



Be sure all 12V connections are secure and sealed. Options include soldering and heat-shrink tubing, crimp connectors, terminal blocks, wire nuts, etc.

Splice Snap Connectors

Splice Snap Connectors are for joining two strips to create a continuous run of LED lighting.

Splice Snap Connector

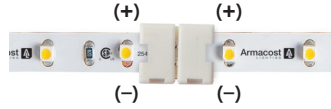

If the + / - marks do not line up, flip the tape and use the opposite end for proper alignment.

How to use Snap Connectors

- Pry open lid on the snap connector (splice connector has two lids).
- Using a side-to-side motion, carefully slide tape strip into connector channel as shown below so the copper pads on the tape are positioned underneath the connector contacts.
- Close and snap down lid connector.
- Perform a power test to be sure connection is secure and LEDs light before final installation.
- If LEDs do not light, or LEDs flicker, repeat the steps outlined above.

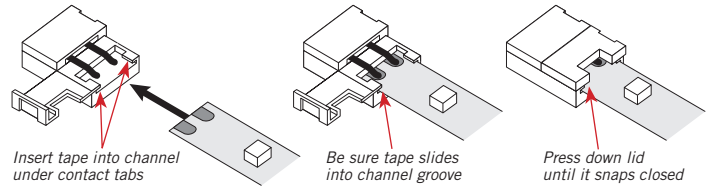
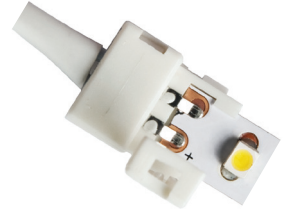

Surface preparation and installing peel-and-stick LED tape lighting

Before removing the 3M tan colored paper backing, it is important to test the LED strip in the space you intend to light. Once the paper backing is removed and the lighting is fully installed, you cannot reposition or move the LED tape light to another location. The tape may not stick securely.

- Power the LED tape lighting and temporarily hold or tape into position with painter's tape or masking tape – do not remove the 3M paper backing.
- Adjust the lighting to various angles and positions to get the desired level of illumination and lighting appearance. If the LEDs create undesirable bright spots on walls, or reflections, reposition the tape light strip farther away from surfaces or try a different mounting angle.
- Once you have determined your final mounting position, clean and prep the surface to ensure the 3M self-adhesive backing will adhere properly.

IMPORTANT

- Mounting surfaces should be smooth, clean, completely dry, dust free and above 60°F (15 °C) before installing/sticking the LED tape lighting.
- Thoroughly clean all mounting surfaces with a 50:50 mixture of isopropyl alcohol and water. For extra dirty surfaces, first use 100% alcohol or acetone. Avoid the use of household cleaners and polishes that may leave behind residues. Also avoid common rubbing alcohol because it frequently contains oils that can interfere with the performance of the 3M adhesive tape.
- For best adhesion – especially when sticking to the underside of cabinets – lightly sand the surface where you will mount the tape lighting. This includes unfinished woods, plastics/laminates and all painted surfaces. Use a very fine grit sandpaper (150-300 grit) and sand in a circular motion rather than straight-line motion for best results.
- When installing on painted surfaces, paint should be fully cured based on manufacturer's cure time.
- Be careful not to peel off the 3M adhesive from LED strip, just remove the tan paper backing. If using LED Snap Connectors, carefully cut the tan backing when it enters the connector. It is beneficial to leave the 3M backing paper inside the connector.
- 3M sticky back tape requires pressure to activate the adhesive. Using a clean dry cloth over your fingers and working from one end to the other, firmly press the tape down the entire length of the strip.

- Be sure to support power wire leads, especially when mounting under cabinets. The weight of a fallen wire lead can pull down the tape lighting, especially on new installations. Note that after 24 hours, 75-80% bond strength is achieved. After 72 hours, 95%+ of the bond strength is achieved. The adhesive bond will continue to build with time.

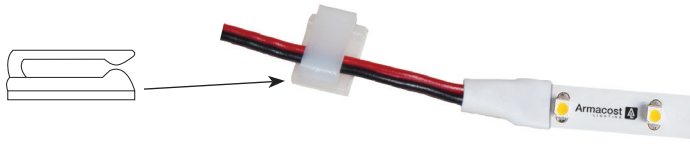

Although RibbonFlex Pro can be installed in curved and irregular spaces, avoid sharp bends or bending on the solder joints as you could damage the LED tape light. If an LED is inadvertently damaged and fails to light, the remaining LEDs will continue to operate. RibbonFlex Pro is made with 3 LEDs connected as one series. If you experience a failure, you can cut out and remove the damaged 3-LED series and splice together new and/or remaining LED tape.

Under Cabinet

To surface mount LED tape lighting under a set of cabinets in one continuous run, you may need to drill a 1/2" hole through any cabinet side lip that may be present. Install LED tape lighting through the hole and surface mount as a continuous run.

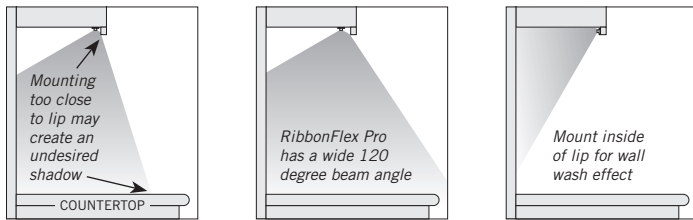

When mounting under a cabinet or a shelf with no lip to hide the LED tape light strip, create a visual barrier by using trim strip molding mounted in front of the LED tape light.



Above Cabinet Uplighting

Most cabinet tops have uneven surfaces. To create beautiful indirect uplighting over cabinets, simply mount RibbonFlex Pro on any rigid strip (e.g., thin lattice or corner guard molding) and place on top of cabinets. Angle the strip position to achieve the desired illumination.

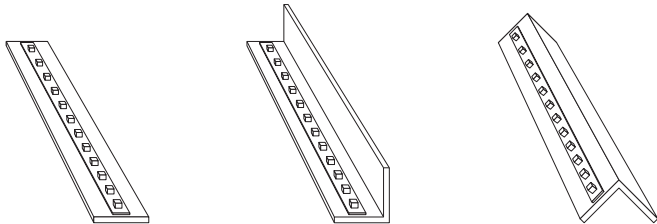

For a seamless glow and to avoid bright light spots, keep LED tape light strip at least 3/4" away from walls.

Cove Lighting

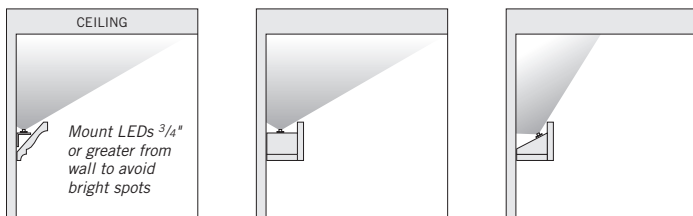

Troubleshooting

Tape light strip does not light

- Make sure your LED power supply is turned on and receiving power.
- Confirm you have maintained correct polarity (+ to + and - to -) when joining LED strips as well as when connecting to the 12V power supply.
- Check all tape light connections and any switch or dimmer connections from the power supply to the LED tape light. Consider testing with a multimeter to ensure light strip is receiving 12V power.

Only part of the LED tape light strip is lit

- Check connections to the part of the strip that is not lit.
- Confirm that you have maintained correct polarity to the unlit section.
- If only 1 LED series is out, cut out and remove the damaged 3-LED group and splice together LED tape strips or replace with new 3-LED section.

LED tape lights blink on, then go off

- Your power supply is not adequate for the length of LED tape light you are powering. Install a higher wattage power supply or reduce watts used by shortening the lengths of your LED tape lighting.

LEDs farthest from the power supply are noticeably dimmer

- This is the result of voltage drop. Decrease the length of the 12V power feed wires or use thicker power feed wires between the 12V power supply and the tape lighting.
- Use shorter lengths of LED tape lighting. Refer to **Configuration options** in these guidelines. Consider a different configuration.

Visit armacostlighting.com/installation for additional installation tips and FAQs.

Limited 3-year warranty

Improper installation, improper powering, abuse, or failure to use this LED tape light for its intended purpose will void warranty. LED tape light cannot be returned or exchanged once cut unless under warranty replacement. Proof of purchase is required for all returns. Questions? Email support@armacostlighting.com.

SPECIFICATIONS

Input Voltage.....	12V DC
LED Count	60 LEDs/m
LED Module	SMD 3528
Chip Size	10 x 23µ
Beam Angle	120° wide
Tape Height/Width	1.5 x 8mm
Cuttable.....	Every 2" approx (50mm)
Lumens Per LED	~7-8 lm
Color Accuracy (CRI).....	~80
Listings	CE, RoHS, CSA
Country of Origin	China



140 Baltic Avenue
Baltimore, MD 21225

armacostlighting.com

