



Single-Stage Snow thrower

Operator's Manual

MODEL NUMBER
YB4628

SERIAL NUMBER

PURCHASE DATE

Both model number and serial number may be found on the main label. You should record both of them in a safe place for future use.

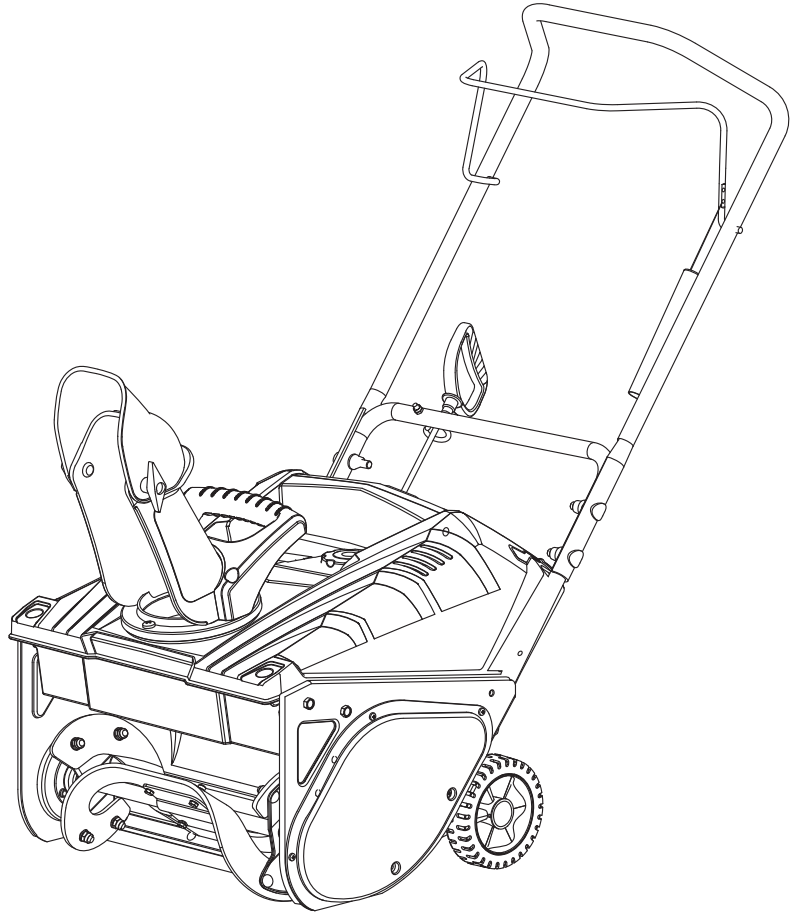

FOR YOUR SAFETY

READ AND UNDERSTAND THE ENTIRE MANUAL BEFORE OPERATING MACHINE

Your new YARDMAX™ snow thrower offers quality construction, and is easy and safe to operate. With proper use and care, it is designed to give you many years of dependable service.

Prepare to experience the durability to take on any job with the ease, portability, and convenience of your new snow thrower!

Discover the YARDMAX Advantage

At YARDMAX, we understand that land ownership definitely has its privileges, but it also comes with a great deal of responsibility. When duty calls and you need to respond, will you have what it takes to tame the great outdoors?

When looking for outdoor power equipment (OPE) to get the job done right, at the right price, YARDMAX delivers the perfect combination of performance and practicality. YARDMAX has a solution that’s right for you.

MAX Performance, MAX Value, MAX Support – that’s YARDMAX

- ✓ Backed by decades of proven manufacturing expertise
- ✓ Enhanced design features come standard
- ✓ Engineered for the best user experience
- ✓ Quality metal parts are used instead of plastic
- ✓ A robust warranty supports all products
- ✓ Budget-friendly prices make it practical



Up for the job? YARDMAX is.

TABLE OF CONTENTS

Introduction	1
Specifications	3
Symbols	4
Safety	5
Contents Supplied	8
Assembly	9

Know Your Machine	11
Operation	15
Maintenance	16
Service	16
Troubleshooting	18
Parts Diagram	20



Carefully read through this entire operator's manual before using your new unit. Pay attention to all cautions and warnings.

This unit is a gasoline engine driven snow thrower. It is perfect for tackling light to medium snow fall - easily able to remove snow up to 11" deep. It is easy and safe to operate. With proper use and care, it should give you many years of dependable service.

ENGINE MANUAL

Please refer to the **Engine Manufacturer's** owner/operator's manual, packed separately with your unit, for more information.

EMISSION CONTROL SYSTEM

This equipment or its engine may include exhaust and evaporative emission control system components required to meet U.S. Environmental Protection Agency (EPA) and/or California Air Resources Board (CARB) regulations. Tampering with emission controls and components by unauthorized personnel may result in severe fines or penalties. Emission controls and components can only be adjusted by an authorized engine manufacturer's service center.

CALIFORNIA PROPOSITION 65 WARNING

Engine exhaust, some of its constituents and certain product components contain or emit chemicals known to the state of California to cause cancer and birth defects or other reproductive harm.

ENVIRONMENTAL



Recycle unwanted materials instead of disposing of them as waste. All tools, hoses, and packaging should be taken to the local recycling center and disposed of in an environmentally safe way.

MODEL AND SERIAL NUMBERS

Record the model and serial number as well as date and place of purchase for future reference. Have this information available when ordering parts or optional accessories and when making technical or warranty inquiries.

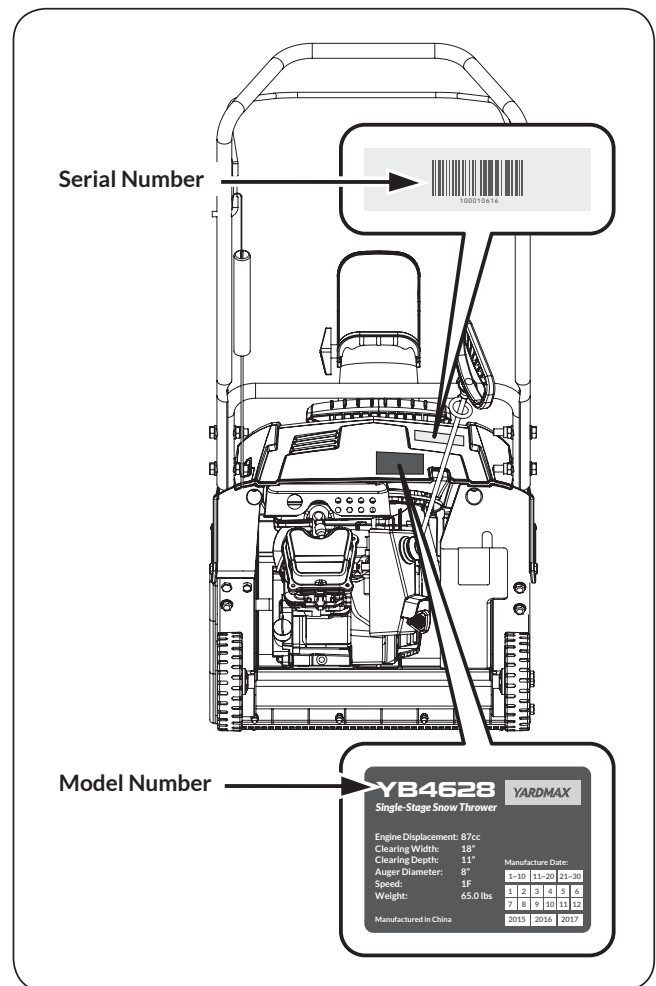

DISCLAIMER

YARDMAX reserves the right to discontinue, change, and improve its products at any time without notice or obligation to the purchaser. The descriptions and specifications contained in this manual were in effect at printing. Equipment described within this manual may be optional. Some illustrations may not be applicable to your unit.

SUPPORT

Have questions about your YARDMAX equipment?
Call us at 844-YARDMAX, email us at
support@yardmax.com, or contact us via your
favorite social media site.

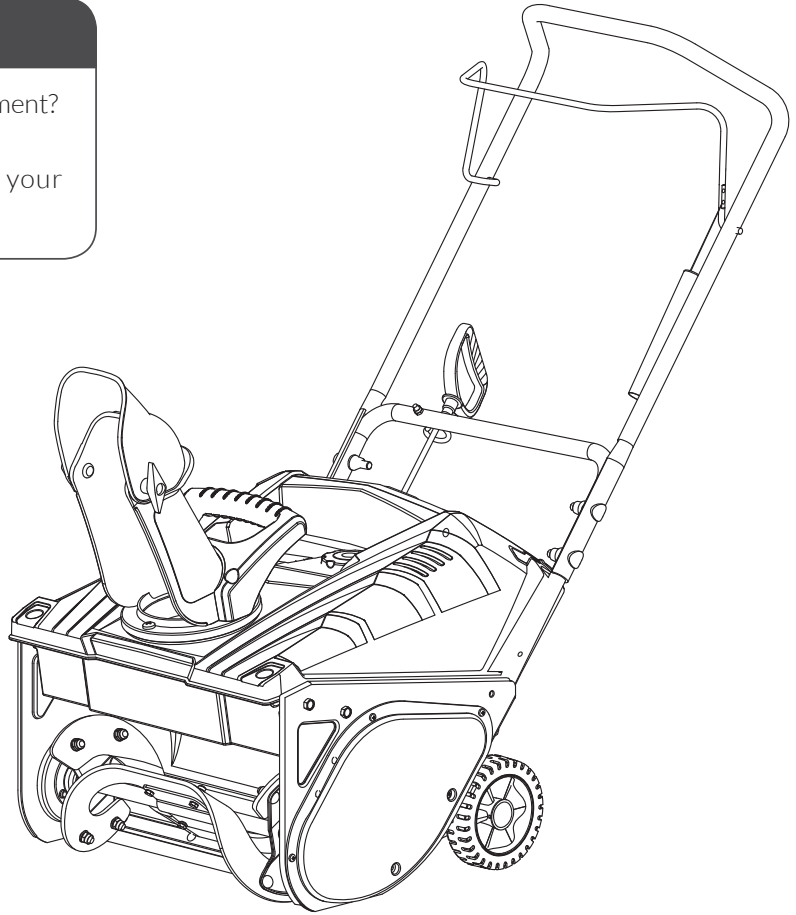

SPECIFICATIONS

Model Number	YB4628
Clearing Width	18"
Engine	YARDMAX
Displacement	87 cc
Start Type	Recoil
Auger Diameter	8"
Clearing Depth	11"
Product Weight	65 lbs

SYMBOLS

The rating plate on your machine may show symbols. These represent important information about the product or instructions on its use.



Read these instructions carefully.



Wear eye protection.
Wear hearing protection.



Wear safety footwear.



Keep children and bystanders off and away.



Stop engine and remove ignition key prior to leaving the operator's position.



Only use clean-out tool to clear blockage.
Never use your hands.



Do not use the chute handle to lift the unit.



Do not remove or tamper with the protection and safety devices.



No smoking, sparks, or flames.



Do not touch parts which are hot from operation. Serious burns may result.



Stop engine, remove key, read manual before making any repairs or adjustments.



Stay away from rotating augers.



Keep hands out of the inlet and discharge openings while machine is running.



Thrown Objects.

SAFETY

GENERAL SAFETY RULES

UNDERSTAND YOUR MACHINE

Read this manual and labels affixed to the machine to understand its limitations and potential hazards.

Be thoroughly familiar with the controls and their proper operation. Know how to stop the machine and disengage the controls quickly.

Make sure to read and understand all the instructions and safety precautions as outlined in the **Engine Manufacturer's** manual packed separately with your unit. Do not attempt to operate the machine until you fully understand how to properly operate and maintain the engine and how to avoid accidental injuries and/or property damage.

If the unit is to be used by someone other than original purchaser or loaned, rented, or sold, always provide this manual and any needed safety training before operation. The user can prevent and is responsible for accidents or injuries that may occur to themselves, other people, and property.

Do not force the machine. Use the correct machine for your application. The correct machine will do the job more efficiently and safer at the rate it was designed.

PERSONAL SAFETY

Do not permit children to operate this machine at any time.

Keep children, pets, and other people not using the unit away from the work area. Be alert and shut off unit if anyone enters work area. Keep children under the watchful care of a responsible adult.

Do not operate the machine while under the influence of drugs, alcohol, or any medication that could affect your ability to use it properly.

Dress properly. Wear heavy long pants, boots, and gloves. Do not wear loose clothing, short pants, or jewelry of any kind. Secure long hair so it is above shoulder level. Keep your hair, clothing, and gloves away from moving parts. Loose clothes, jewelry, or long hair can be caught in moving parts.

Protect eyes, face, and head from objects that may be thrown from the unit. Always wear safety goggles or safety glasses with side shields when operating.

Wear appropriate hearing protection.

Always keep hands and feet away from all moving parts during operation. Moving parts can cut or crush body parts.

Always keep hands and feet away from all pinch points.

Do not touch parts that might be hot from operation. Allow parts to cool before attempting to maintain, adjust, or service.

Stay alert, watch what you are doing, and use common sense when operating the machine.

Do not overreach. Do not operate the machine while barefoot or when wearing sandals or similar lightweight footwear. Wear protective footwear that will protect your feet and improve your footing on slippery surfaces. Keep proper footing and balance at all times. This enables better control of the machine in unexpected situations.

INSPECT YOUR MACHINE

Check your machine before starting it. Keep guards in place and in working order. Make sure all nuts, bolts, etc., are securely tightened.

Never operate the machine when it is in need of repair or is in poor mechanical condition. Replace damaged, missing, or failed parts before using it. Check for fuel leaks. Keep the machine in safe working condition.

Do not use the machine if the engine's switch does not turn it on or off. Any gasoline powered machine that can't be controlled with the engine switch is dangerous and must be replaced.

Regularly check to see that keys and adjusting wrenches are removed from the machine area before starting it. A wrench or a key that is left attached to a rotating part of the machine may result in personal injury.

Avoid accidental starting. Be sure the engine's switch is off before transporting the machine or performing any maintenance or service on the unit. Transporting or performing maintenance or service on a machine with its switch on invites accidents.

If the machine should start to vibrate abnormally, stop the engine (motor) and check immediately for the cause. Vibration is generally a warning sign of trouble.

ENGINE SAFETY

This machine is equipped with an internal combustion engine. Do not use on or near any unimproved, forest covered, or brush covered land unless the exhaust system is equipped with a spark arrester meeting applicable local, state, or federal laws.

In the state of California, a spark arrester is required by law. Other states have similar laws. A spark arrester, if used, must be maintained in effective working order by the operator.

Never start or run the engine inside a closed area. The exhaust fumes are dangerous, containing carbon monoxide, an odorless and deadly gas. Operate this unit only in a well-ventilated outdoor area.

Do not tamper with the engine to run it at excessive speeds. The maximum engine speed is preset by the manufacturer and is within safety limits. See engine manual.

Keep a Class B fire extinguisher on hand when operating this snow thrower in dry areas as a precautionary measure.

FUEL SAFETY

Fuel is highly flammable, and its vapors can explode if ignited. Take precautions when using to reduce the chance of serious personal injury.

When refilling or draining the fuel tank, use an approved fuel storage container while in a clean, well-ventilated outdoor area. Do not smoke, or allow sparks, open flames, or other sources of ignition near the area while adding fuel or operating the unit. Never fill the fuel tank indoors.

Keep grounded conductive objects, such as tools, away from exposed, live electrical parts and connections to avoid sparking or arcing. These events could ignite fumes or vapors.

Always stop the engine and allow it to cool before filling the fuel tank. Never remove the cap of the fuel tank or add fuel while the engine is running or when the engine is hot. Do not operate the machine with known leaks in the fuel system.

Loosen the fuel tank cap slowly to relieve any pressure in the tank.

Never overfill the fuel tank. Fill the tank to no more than 1/2" below the bottom of the filler neck to provide space for expansion as the heat of the engine can cause fuel to expand.

Replace all fuel tank and container caps securely and wipe up spilled fuel. Never operate the unit without the fuel cap securely in place.

Avoid creating a source of ignition for spilled fuel. If fuel is spilled, do not attempt to start the engine but move the machine away from the area of spillage and avoid creating any source of ignition until fuel vapors have dissipated.

When fuel is spilled on yourself or your clothes, wash your skin and change clothes immediately.

Store fuel in containers specifically designed and approved for this purpose.

Store fuel in a cool, well-ventilated area, safely away from sparks, open flames, or other sources of ignition.

Never store fuel or a machine with fuel in the tank inside a building where fumes may reach a spark, open flame, or any other source of ignition, such as a water heater, furnace, or clothes dryer. Allow the engine to cool before storing in any enclosure.

SPECIFIC SAFETY RULES

Do not operate without wearing adequate winter outer garments.

Do not use the machine on a roof.

Do not run the engine indoors, except when starting the engine and for transporting the snow thrower in or out of the building. Open the outside doors; exhaust fumes are dangerous.

Always check overhead and side clearances carefully before operation. Always be aware of traffic when operating along streets or curbs.

Thoroughly inspect the area to be worked. Keep the working area clean and free of toys, doormats, newspapers, sleds, boards, wires and other foreign objects, which could be tripped over or thrown by the auger/impeller. Check for weak spots on docks, ramps or floors.

Plan your snow-throwing pattern to avoid discharge toward people or areas where property damage can occur.

Do not operate near drop-offs, ditches, or embankments. Machine can suddenly turn over if a wheel is over the edge of a cliff or ditch, or if an edge caves in.

Keep all bystanders, children, and pets at least 75 feet (23m) away. If you are approached, stop the unit immediately.

Use a grounded three-wire extension cord and receptacle for all machines with electric start engines.

Check clutch and brake operation frequently. Adjust and service as required. All motion of drive wheels and auger/impeller must stop quickly when control levers are released.

Let engine and machine adjust to outdoor temperature before starting to clear snow.

Stay alert for hidden hazards or traffic.

Do not overload machine capacity by attempting to clear snow at too fast of a rate.

Do not throw snow any higher than necessary.

Adjust auger housing height to clear gravel or crushed rock surfaces. Exercise extreme caution when operating.

Exercise caution to avoid slipping or falling, especially when operating in reverse. Never operate machine at high transport speeds on slippery surfaces. Always look down and behind before and while backing.

Do not operate on steep slopes. Do not clear snow across the face of slopes. Keep all movement on slopes slow and gradual. Do not make sudden changes in speed or direction. Use a slow speed to avoid stops or shifts on slopes. Avoid starting or stopping on a slope. Do not park machine on a slope unless absolutely necessary. When parking on a slope, always block the wheels.

Disengage power to the auger/impeller when transporting or not in use.

Disengage all control levers and stop engine before you leave the operating position (behind the handles). Wait until the auger/impeller comes to a complete stop before unclogging the chute assembly, making any adjustments, or inspections.

Hand contact with the rotating impeller inside the discharge chute is the most common cause of injury associated with snow throwers. Do not unclog chute assembly while engine is running. Shut off engine and remain behind handles until all moving parts have stopped before unclogging. Never put your hand in the discharge or collector openings. Always use the clean-out tool provided to unclog the discharge opening.

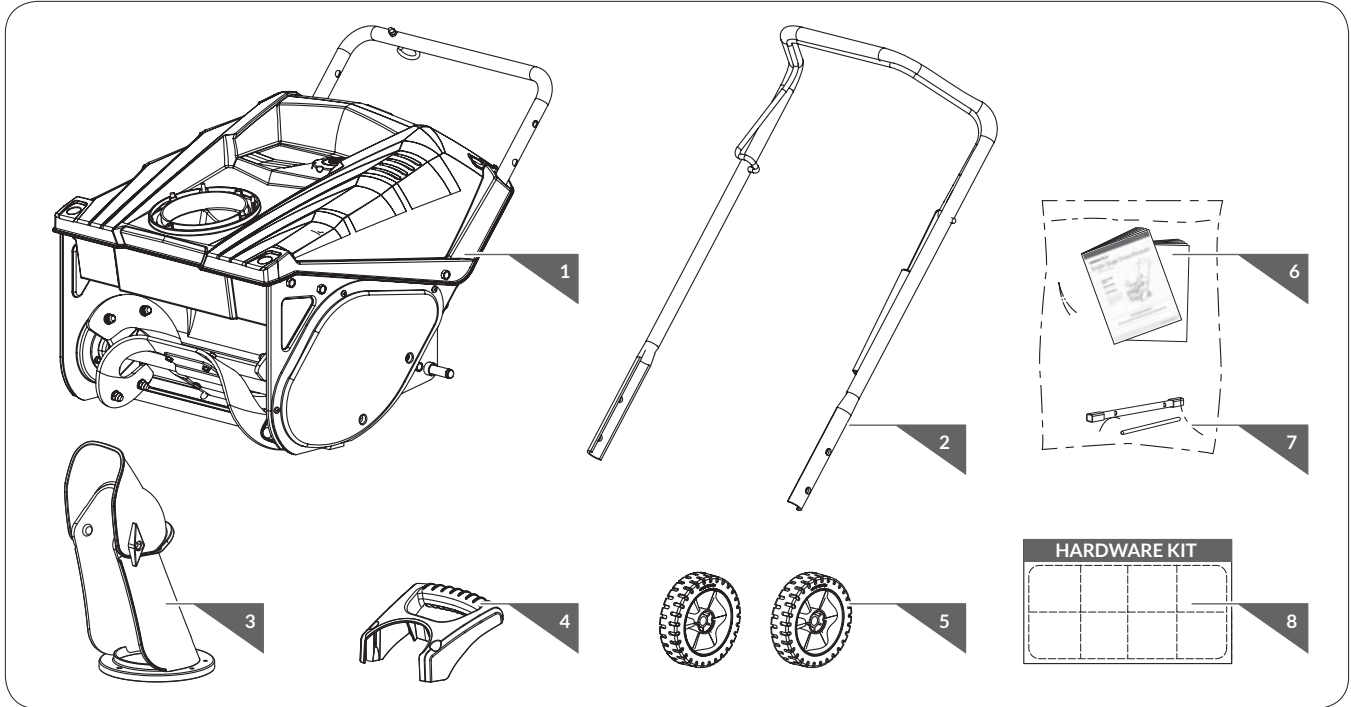

CONTENTS SUPPLIED

Your YARDMAX snow thrower comes partially assembled and contains the following:





1. Main Machine
2. Handlebars
3. Discharge Chute
4. Directional Chute Control Handle
5. Wheels
6. Operator's Manual & Engine Manual
7. Tools for Spark Plug Assembly

8. Hardware Kit, Including

	ST6.3X25	X4	1
		X2	2
	M8 X 45	X4	3

TOUCH-UP PAINT

	Orange	X1	4
	Black	X1	

ASSEMBLY

This snow thrower was partially assembled at the factory. To assemble your machine follow the below instructions.

DISCHARGE CHUTE

1. Align the screw holes and the pin holes with the plastic studs in the chute base with the holes in the lower chute.
2. Secure with the self-tapping screws on the front, or open side, of the chute and the backside first.
3. Slide the chute handle over the chute and secure both sides with the remaining two screws.

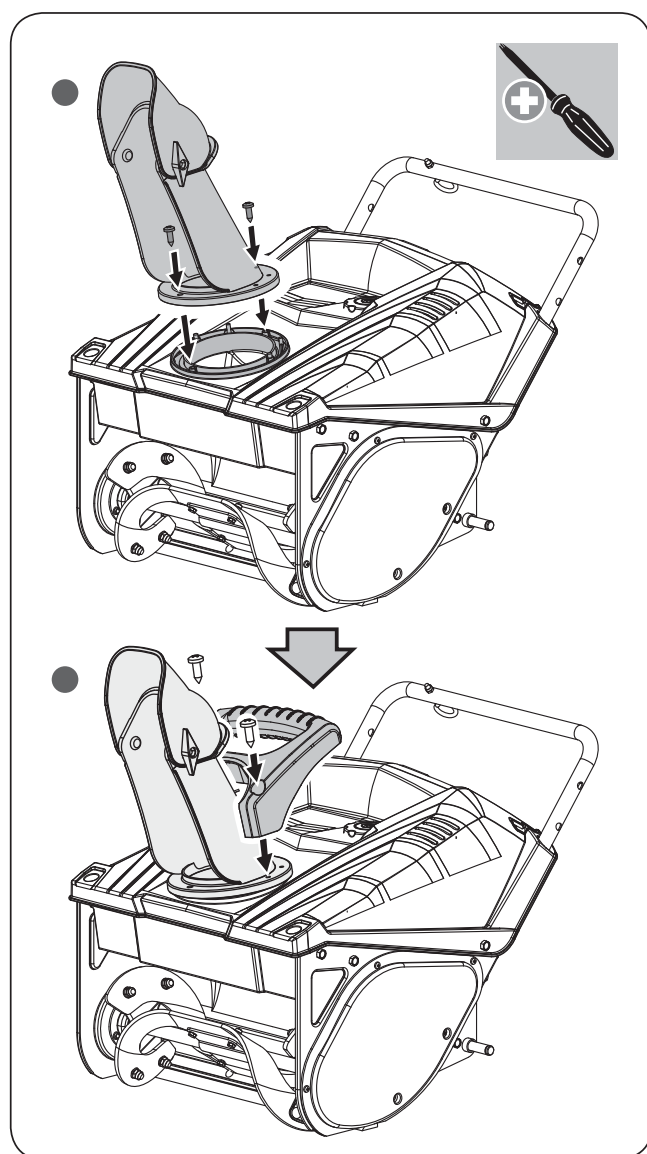

Figure 1



ST6.3 X 25

X 4



Do not overtighten the screws; otherwise you may damage the discharge chute and prevent it from turning freely.

WHEELS

1. Slide the wheel bushing, the wheel with the smooth sides facing out, and the washer onto the axle.
2. Install the snap ring to secure the wheel assembly.
3. Push the wheel cover into the wheel hole.

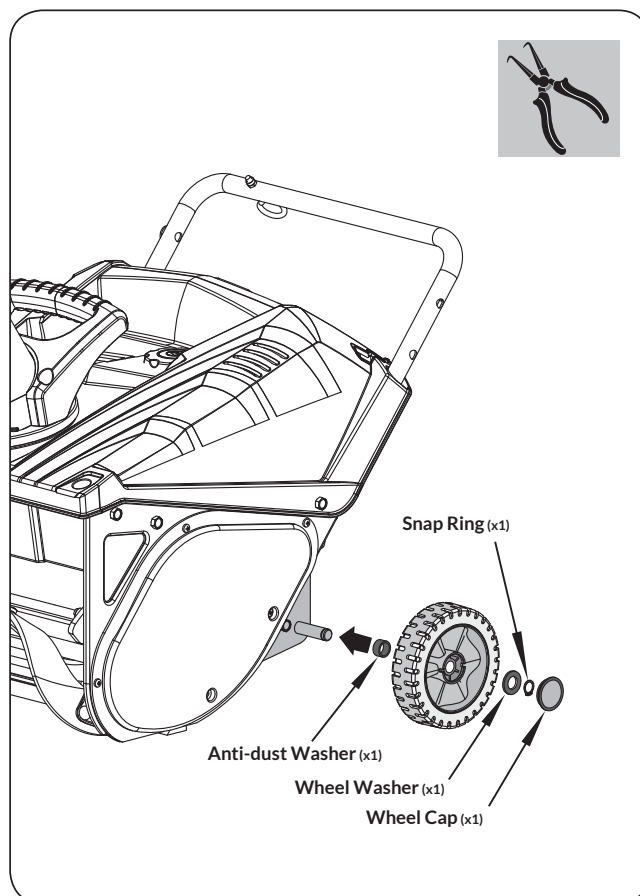

Figure 2



X 2



4. Follow the steps 1-3 to assemble the other wheel.

HANDLEBAR

1. Align the holes in the handlebars and the holes in the lower handle. Note **Figure 3a** below that the handle must face upward to work properly.

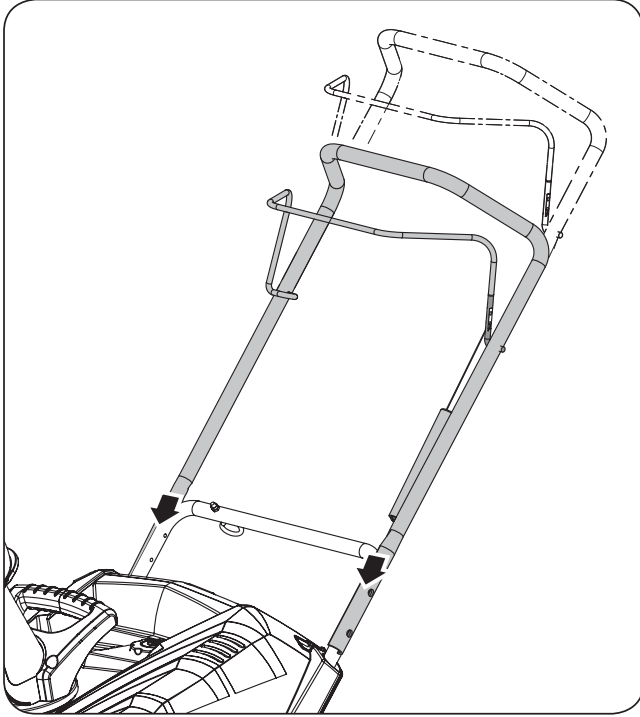

Figure 3a

2. Install the handle to the lower handle using four M8X45 screws, washers and nuts. Be sure not to pinch or kink the auger clutch cable in the process.

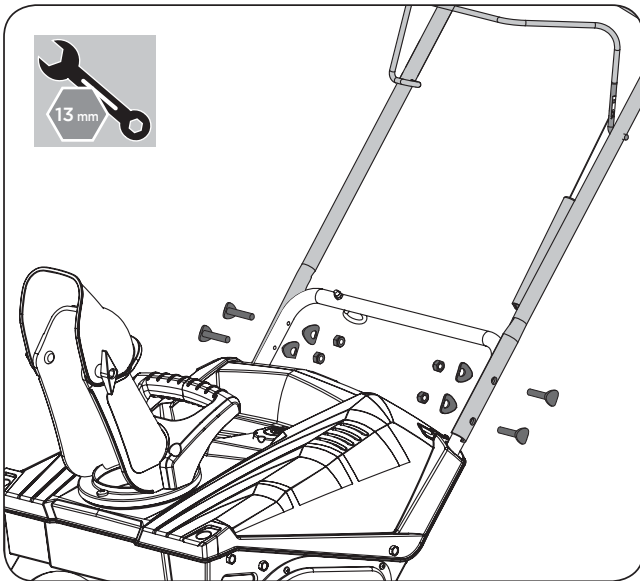

Figure 3b



M8X45

X4

3

RECOIL STARTER

1. Slowly pull the recoil starter handle up towards the eye bolt.
2. Slip the recoil starter rope into the eye bolt from the back of the snow thrower.

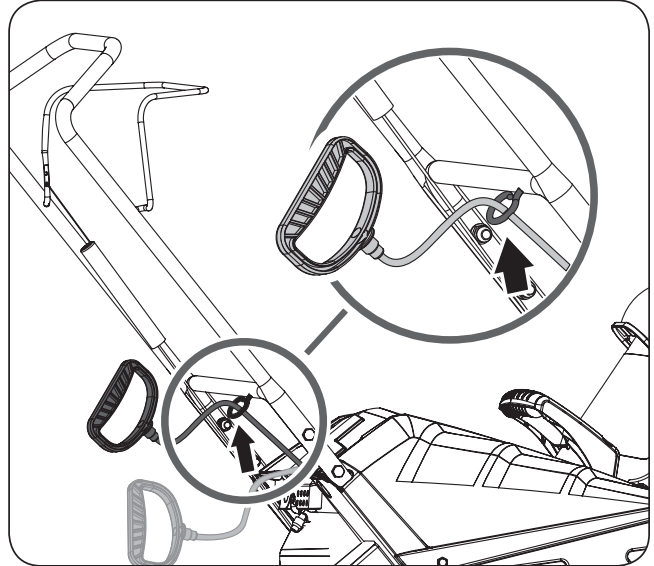

Figure 4

AUGER CLUTCH

1. Remove the cable adjuster link from the hole in the auger clutch handle.
2. Pull the tensioning cable up.
3. Connect tensioning cable with the cable adjuster link.
4. Make sure the cable adjuster link hook the lower hole in the auger clutch handle.

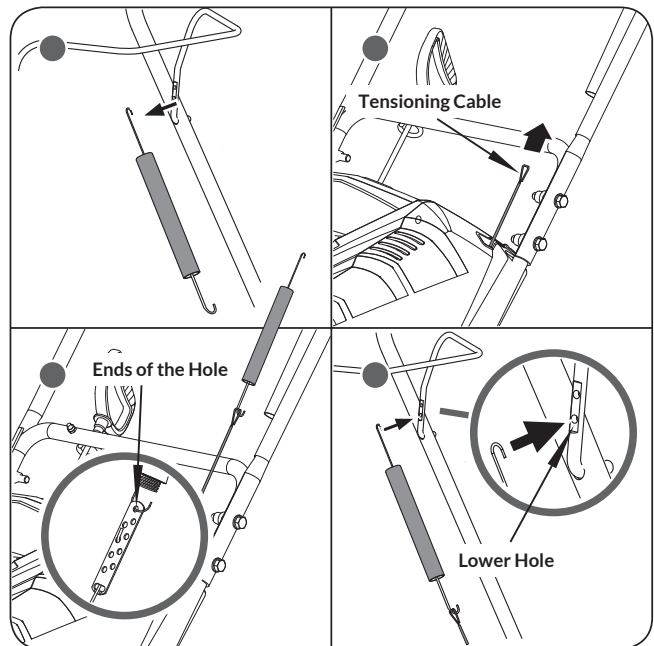
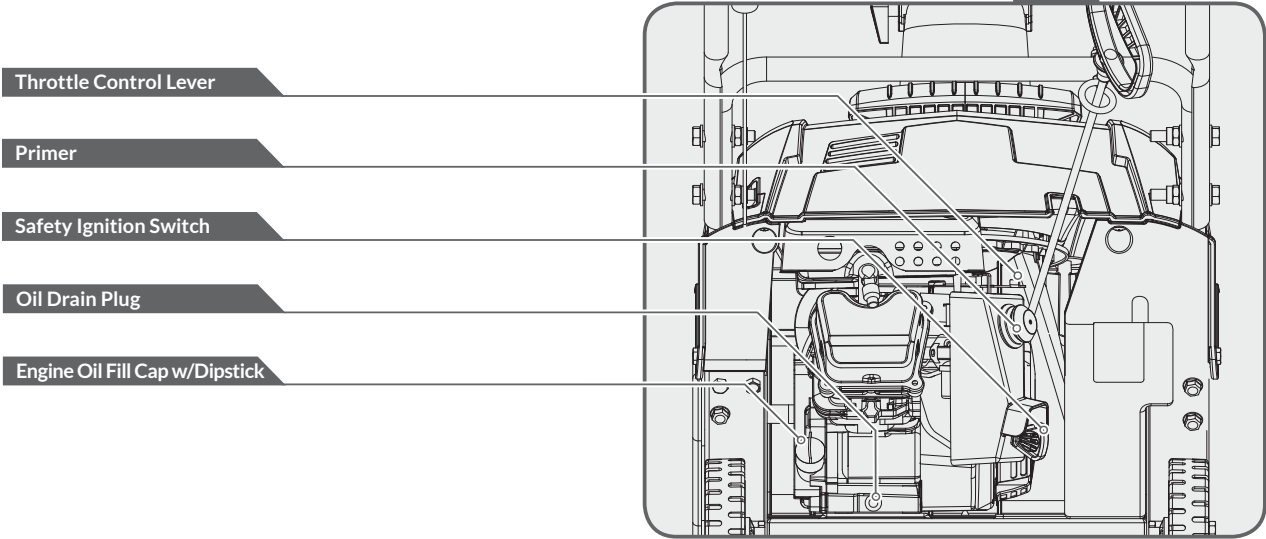
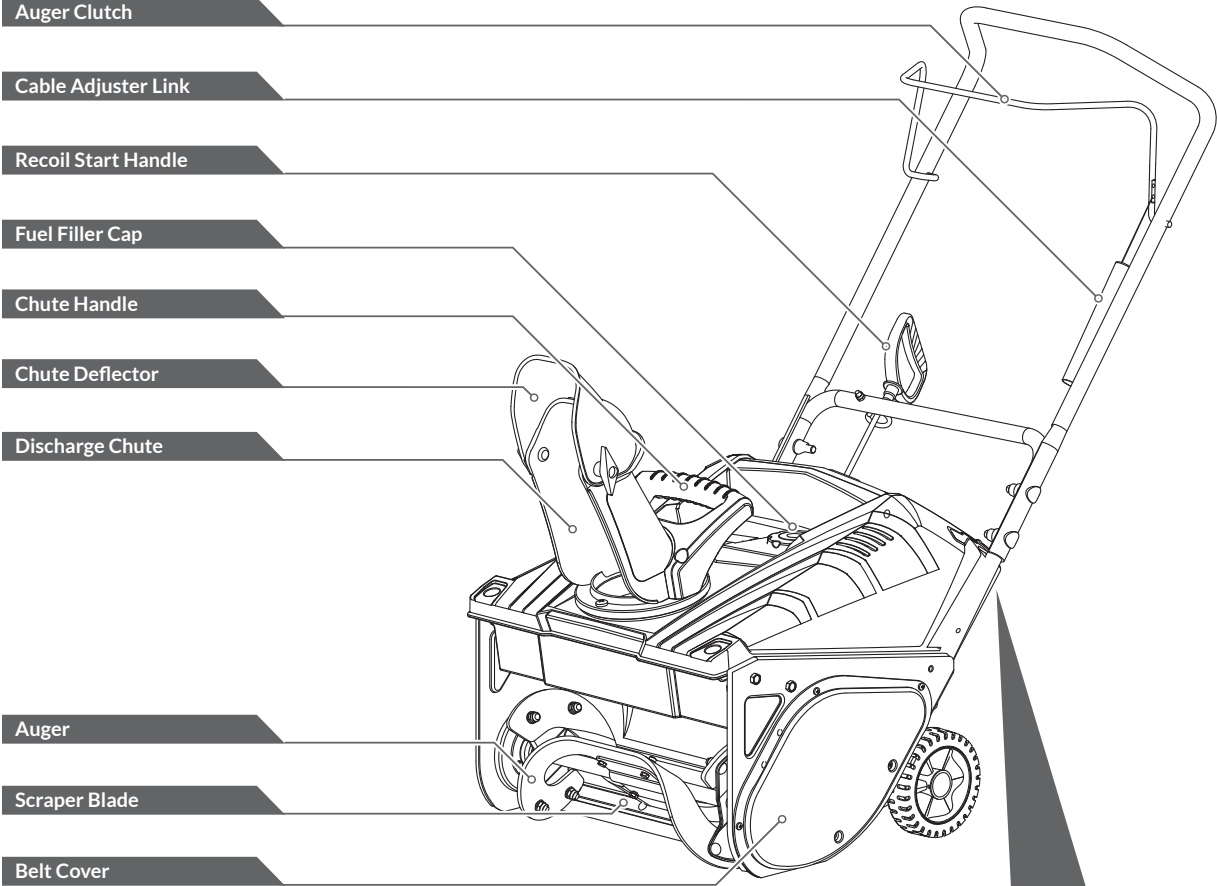

Figure 5

KNOW YOUR MACHINE

FEATURES AND CONTROLS



DISCHARGE CHUTE

- » Grasp the chute handle and rotate the discharge chute to the left or right. A tension plate holds the chute in the desired position.

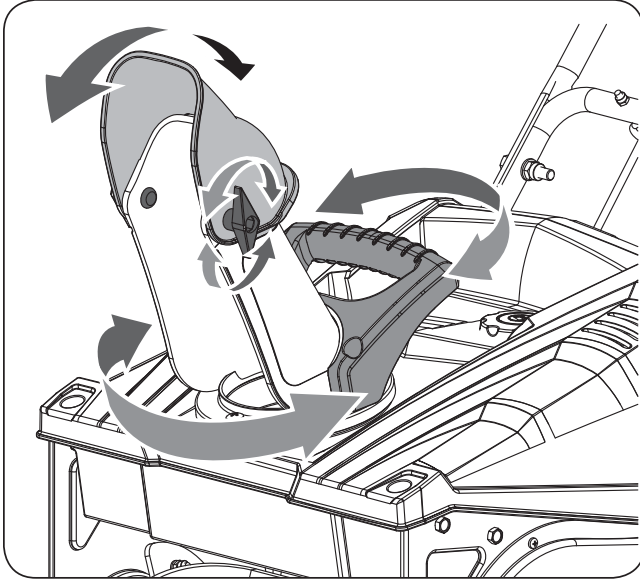

Figure 6



Do not use the chute handle to lift the unit.

CHUTE DEFLECTOR

- » Loosen the deflector wing knob and adjust the chute deflector up or down to control the snow discharge height and distance. Tighten the wing knob securely to hold the desired deflector adjustment once the desired position have been achieved.

AUGER CLUTCH

- » To engage the auger and start throwing snow, hold the auger clutch against the handle.

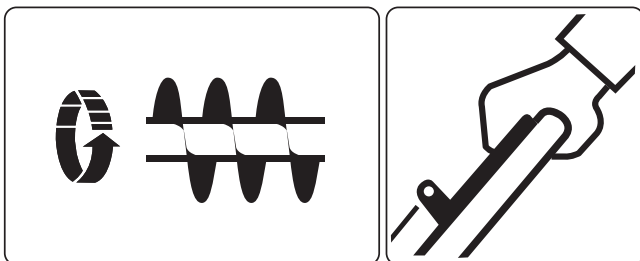

Figure 7a

- » To disengage the auger, release the auger clutch.

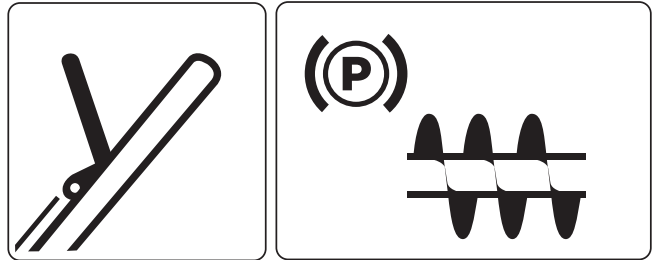

Figure 7b

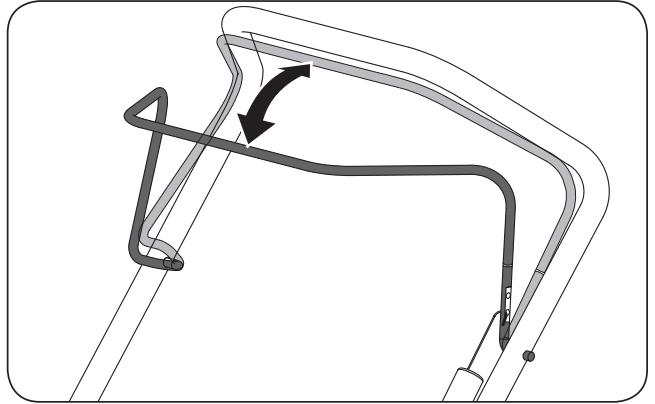

Figure 7c

AUGER & SCRAPER BLADE

- » When engaged, the auger rotates and draws snow into the auger housing and throws it out the discharge chute. Rubber paddles on the auger also aid in propelling the snow thrower as they come in contact with the pavement.



During initial break-in period of the auger, it is normal for the auger to build up excessive heat if not operated in the snow. Do not operate without snow or water for lubricating the auger. This will cause excessive heat build up in the auger which could cause damage to the auger and scraper blade.

- » The scraper blade maintains contact with the pavement as the snow thrower is propelled, allowing snow close to the pavement's surface to be discharged.

- » The auger and the scraper blade are subject to wear and damage. They should be checked periodically. Adjust or replace when necessary.

- » During initial operation there may be wear between the auger and the scraper blade. Maximum performance, both snow throwing and driving, occurs when there is zero clearance between these two parts.

CHOKE

- Engage choke by rotating lever to CLOSED position whenever you are starting a cold engine. As engine warms up, gradually rotate the choke to the OPEN position.



Do not use choke to start a warm engine.



Never use choke to stop engine.

PRIMER

- Press the primer to pump additional fuel from the carburetor to the cylinder for improved cold weather starting.
- Firmly push in the primer with your thumb, holding the primer in for a second before releasing it each time.
- Remove your glove when you push in the primer so that air can not escape from the primer hole.



Do not use the primer if the engine has been running and is hot. Excessive priming may flood the engine and prevent it from starting.

RECOIL STARTER

- The recoil starter is on the back side of the engine. Pull the recoil starter handle to start the engine.

SAFETY IGNITION SWITCH

- Insert the safety ignition key for engine to start and run. To stop the engine, remove the key.

SCRAPER BLADE

- When the snow thrower is on a level surface the wheels, scraper blade, and auger should all contact the surface. If the scraper blade is adjusted too high, snow may blow under the housing. If the scraper blade wears out excessively, or the snow thrower does not self-propel, the scraper blade may be too low and needs to be adjusted.
- On new snow throwers with a new scraper blade installed, the auger may be slightly off the ground.
 - Follow these steps to adjust the scraper blade:
 - Run the snow thrower until the fuel tank is empty.
 - Pull the recoil starter handle until resistance is felt. Then tip the snow thrower back until it rest on the handle.
 - Loosen the four flange lock nuts and carriage screws which secure the scraper blade to housing. Move the scraper blade to the desired position and retighten the nuts and screws securely.

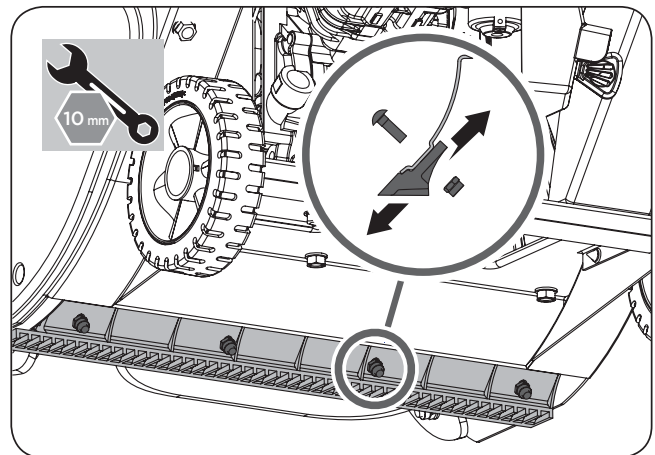

Figure 8

- Tip the snow thrower back to the operating position and pull the starter handle a few times to see if it is difficult to pull.
- If the starter is difficult to pull, remove the spark plug and pull the handle several times to ensure that any oil trapped in the head is removed.



Oil may come out of the spark plug hole when it is removed and the starter handle is pulled.

- Inspect the spark plug. If it is wet, clean off any oil before re-installing.

AUGER CLUTCH

» The auger will not turn unless the auger clutch is engaged. The auger must stop within 5 seconds after the auger clutch is released.

» The clutch cable must contain some slack when you disengage the clutch lever for the auger to stop properly.

» If the auger no longer turns when the auger clutch is engaged or if the belt slips under load, the auger cable or belt may have stretched. This can be compensated for by adjusting the auger clutch cable.

» The upper hole in auger clutch lever provides for a quick adjustment method. To adjust, unhook and move the clutch cable to the upper position. Insert the cable from the outside.

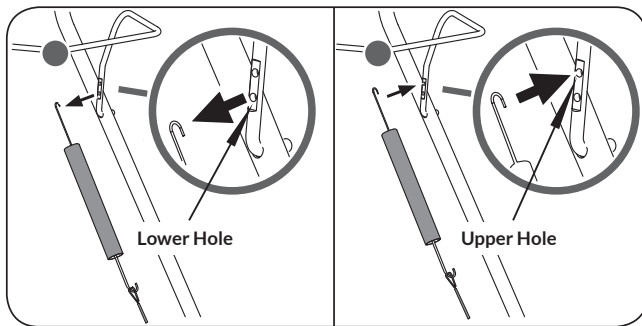
**Figure 9a**

» The cable adjuster link found under the spring cover provides further adjustment options if required.

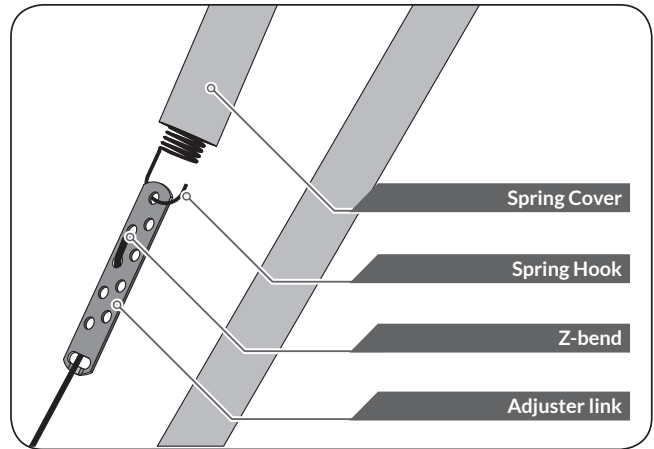
**Figure 9b**

1. Slide up the spring cover and unhook the spring from the adjuster link.

» You can pull up the adjuster link and cable to make unhooking the spring easier.

2. Move the Z-bend to a higher or lower hole on the adjuster link as needed to obtain proper auger clutch adjustment.

3. Hook the spring to the adjuster link and slide the spring cover over the adjuster link.

» Test the snow thrower to see if there is a noticeable difference. If after the adjustment to the control cable the auger still hesitates when rotating, replace the auger belt.

OPERATION

STARTING AND STOPPING THE ENGINE



Before starting the engine, check engine oil level and ensure the engine is maintained as described in the **Engine Manual** with the snow thrower.

COLD START – RECOIL STARTER

1. Be sure fuel shutoff valve is in the OPEN position.
2. Place ON / OFF switch in ON position.
3. Rotate choke control to CLOSED position.
4. Push the primer 2 or 3 times. When temperature is below 15°F (-25°C), additional priming may be needed. When temperature is above 50°F (10°C), priming is not necessary.

» Over priming may cause flooding, preventing the engine from starting. If you do flood the engine, wait a few minutes before attempting to start and do not push the primer.

5. Grasp recoil starter handle and pull rope out slowly until it pulls harder. Let rope rewind slowly.
6. Pull rope with a rapid continuous full arm stroke. Do not allow starter rope to snap back.
7. Repeat steps 5 and 6 until engine starts.
8. When the engine starts, release the recoil starter handle and slowly move the choke control to the OPEN position.

WARM START

Follow the steps above, except place the choke in the OPEN position and do not prime the engine prior to starting.

» Allow the engine to warm up for a few minutes, engine will not develop full power until it has reached normal operating temperature.

» In snowy and cold conditions, some controls and moving parts may freeze. Do not use excessive force when trying to operate frozen controls. If you have difficulty operating any control or part, start the engine and let it run for a few minutes.

SNOW BLOWING TIPS

It is easier and more efficient to remove snow immediately after it falls.

The best time to remove snow is the early morning. At this time the snow is usually dry and has not been exposed to the direct sun and warming temperatures.

Slightly overlap each successive path to ensure all snow will be removed.

For large areas, start in the middle and throw snow to each side, so snow is not cleared more than once.

For extremely heavy snow, reduce the width of snow removal by overlapping previous path and move slowly.

Throw snow downwind whenever possible.

Keep engine clean and clear of snow during use. This will help air flow and extend engine life.

After snow-throwing is completed, let the engine run for a few minutes to help dry off the moisture on the engine and prevent moving parts from freezing. Engage the auger to clear any remaining snow from inside the housing. Rotate the discharge chute to prevent it from freezing. Stop the engine, wait for all moving parts to stop, and remove all ice and snow from the snow thrower. With the engine off, pull the recoil starter handle several times to prevent the recoil starter from freezing up.

UNCLOGGING DISCHARGE CHUTE



Never use your hands to clear a clogged discharge chute. Shut off engine and remain behind handle until all moving parts have stopped before unclogging.

1. Shut off the engine.
2. Wait 10 seconds to be sure the auger has stopped rotating.
3. Always use a clean-out tool or stick at least 16" (400mm) long, not your hands.

SELF-PROPELLED OPERATION

Tip the handle forward slightly to allow the rubber paddles on the auger to contact the pavement and propel the snow thrower forward. Pushing downward on the handle will raise the auger off the ground and stop forward motion.



Excessive upward pressure on the handle will result in premature wear on the rubber auger paddles.

TRANSPORTATION



Always shut off engine, remove key, and close fuel shut-off valve when transporting unit on a truck or trailer. Do not transport machine while engine is running.

Use extra care when loading or unloading unit onto trailer or truck.

Never pick up the machine by the auger handle.

Secure unit chassis to transport vehicle. Never secure from rods or linkages that could be damaged.

MAINTENANCE

ENGINE

Refer to the Engine Operator's Manual.

LUBRICATION

Lubricate the pivot points on the auger clutch lever and the spring at the end of the clutch cable with a light oil once every season before off-season storage.

AUGER GEARBOX

Lubricate the pivot points on the auger clutch lever and the spring at the end of the clutch cable with a light oil once every season before off-season storage.

OFF-SEASON STORAGE



Refer to the Engine Manual for information on storing your engine.

At the end of the season or if the Snow thrower will not be used for 30 days longer, follow the storage instructions below.

1. Run the engine until the fuel lines and carburetor are empty and it stops due to lack of fuel.
2. Remove the safety ignition key and allow the engine to cool.
3. Lubricate the machine as instructed.
4. Clean the exterior of the engine and the snow thrower thoroughly.
5. Touch up all rusted or chipped paint surfaces; sand affected areas before painting, and use a rust preventative to prevent the metal parts from rusting.
6. Tighten all loose screws, bolts, and locknuts. Repair or replace any damaged parts.
7. Cover the machine and store it in a clean, dry place out of the reach of children.

SERVICE

AUGER BELT REPLACEMENT

If the auger belt becomes worn, oil-soaked, or otherwise damaged, proceed as follows to replace the belt.

1. Remove the screws that hold the belt cover in place and set the cover aside.

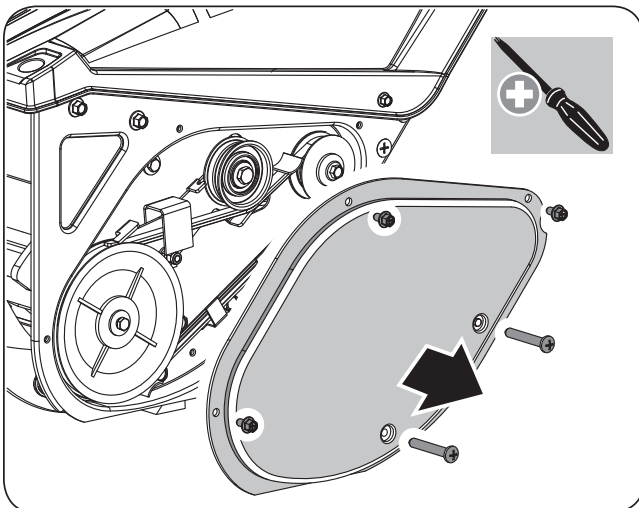

Figure 10a

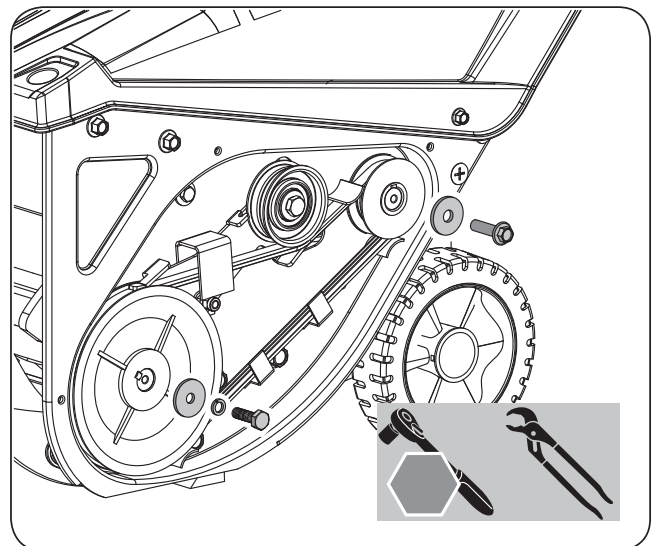

Figure 10b

2. Remove the bolts, big washer, and lock washer from the auger pulley.
3. Using large mouth pliers grip the drive pulley to loosen the bolt.

4. With the help of another pushing down the belt tension idler to keep the idler bracket away from the auger pulley, use two screwdrivers to pry the auger pulley as shown, so that auger pulley becomes loose and away from the axle. (See **Figure 10c**)

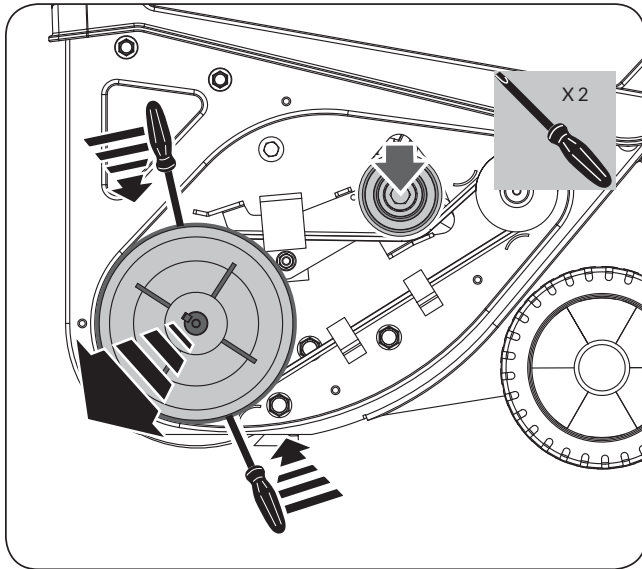

Figure 10c

5. Remove the auger pulley and drive pulley with belt.

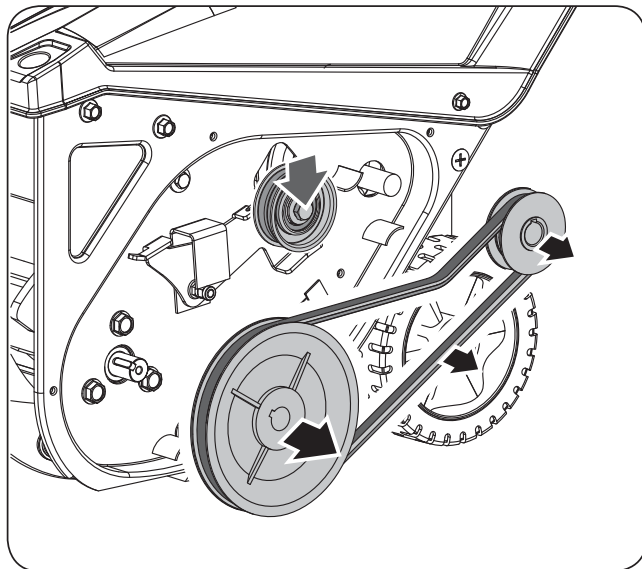

Figure 10d

6. Route the new belt around the drive pulley and under the idler pulley.
7. Route the end of the new belt around the auger pulley and slide the pulley back on to the auger shaft. It may be necessary to push down on the idler pulley to get the auger pulley under the belt keeper. Make sure the grooves in the auger pulley and drive pulley in line with a hammer.

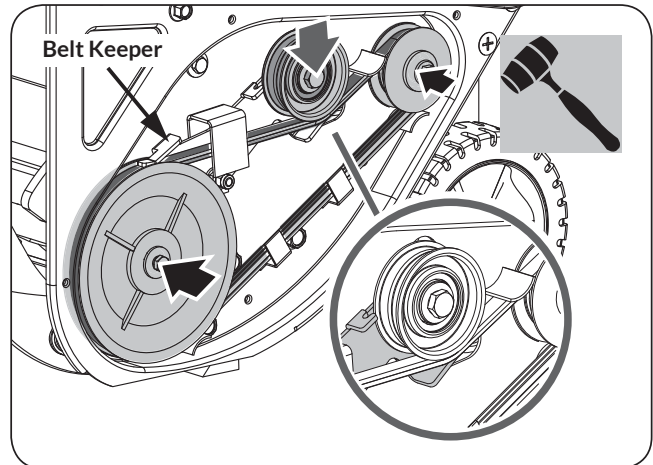

Figure 10e

8. Replace the screws and washers and tighten securely. Turn the auger to ensure no interference.
9. Reinstall the belt cover removed earlier.

AUGER PADDLES REPLACEMENT

The snow thrower auger's rubber paddles are subject to wear and should be replaced if any signs of excessive wear are present.



Do not allow the auger's rubber paddles to wear to the point where portions of the metal auger itself can come in contact with the pavement. Doing so can result in serious damage to the snow thrower.

1. Remove the existing rubber paddles by loosening the screws and nuts which secure them to the auger.

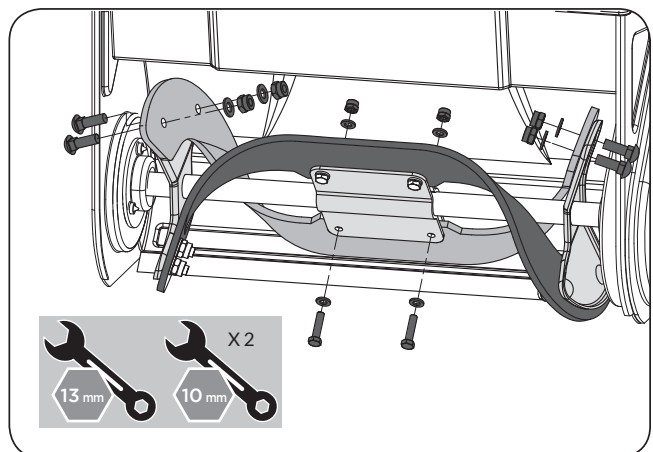

Figure 11



The auger paddles should be replaced one at a time so that the auger still attached can be used as an example for positioning and re-installing the new auger.

2. Secure the replacement rubber paddles to the auger using the hardware removed earlier.

TROUBLESHOOTING

Problem	Cause	Remedy
Engine fails to start	<ol style="list-style-type: none"> 1. Choke not in CHOKE position 2. Engine not primed 3. Engine is flooded 4. Spark plug wire loose or disconnected 5. Fuel tank empty or stale fuel. 6. Faulty spark plug 7. Safety ignition key is not inserted 8. The engine oil level in the engine crankcase is too low or too high 	<ol style="list-style-type: none"> 1. Move choke to CHOKE position 2. Prime engine as instructed in this manual 3. Wait a few minutes before restarting, do not prime 4. Connect or tighten spark plug wire 5. Fill tank with clean, fresh gasoline 6. Clean, adjust gap, or replace 7. Insert safety ignition key 8. Add or drain oil to adjust the oil level in the engine crankcase
Engine idles or runs roughly	<ol style="list-style-type: none"> 1. Engine running on CHOKE 2. Fuel tank is nearly empty or stale fuel 3. Contaminated fuel supply 4. Carburetor out of adjustment 5. Engine over-governed 6. Spark plug wire loose 7. Faulty spark plug 8. The engine oil level in the engine crankcase is too low or too high 	<ol style="list-style-type: none"> 1. Move choke lever to RUN position 2. Fill tank with clean, fresh gasoline 3. Replace with clean fuel 4. Contact a qualified repair personnel 5. Contact a qualified repair personnel 6. Tighten spark plug wire 7. Clean, adjust gap, or replace 8. Add or drain oil to adjust the oil level in the engine crankcase
Loss of power	<ol style="list-style-type: none"> 1. Spark plug wire loose 2. Gas gap vent hole plugged 3. Dirty or clogged muffler 	<ol style="list-style-type: none"> 1. Tighten spark plug wire 2. Clean or replace fuel cap 3. Clean or replace muffler
The engine overheats	Carburetor not adjusted properly	Contact a qualified repair personnel
Excessive vibration	Loose parts or damaged parts	Tighten all fasteners or replace damaged parts.
Snow thrower fails to self-propel	<ol style="list-style-type: none"> 1. Auger clutch cable out of adjustment 2. Auger belt loose or damaged 	<ol style="list-style-type: none"> 1. Adjust auger clutch cable 2. Replace auger belt

Problem	Cause	Remedy
Auger fails to stop within 5 seconds after auger clutch is released	Auger clutch cable out of adjustment	Adjust auger clutch cable.
Snow thrower fails to discharge snow	<ol style="list-style-type: none"> 1. Discharge chute clogged. 2. Auger jammed 3. Auger clutch cable not adjusted properly 4. Auger belt loose or damaged 5. Auger rubber paddles worn or damaged 6. Throwing too much snow 7. Trying to remove extremely heavy or wet snow 8. Auger is frozen in place 	<ol style="list-style-type: none"> 1. Unclog discharge chute 2. Remove debris or foreign object from auger 3. Adjust auger clutch cable 4. Replace auger belt 5. Replace rubber paddles 6. Reduce width of swath 7. Do not overload with extremely heavy or wet snow 8. Move unit to a warm place to thaw

PARTS DIAGRAM

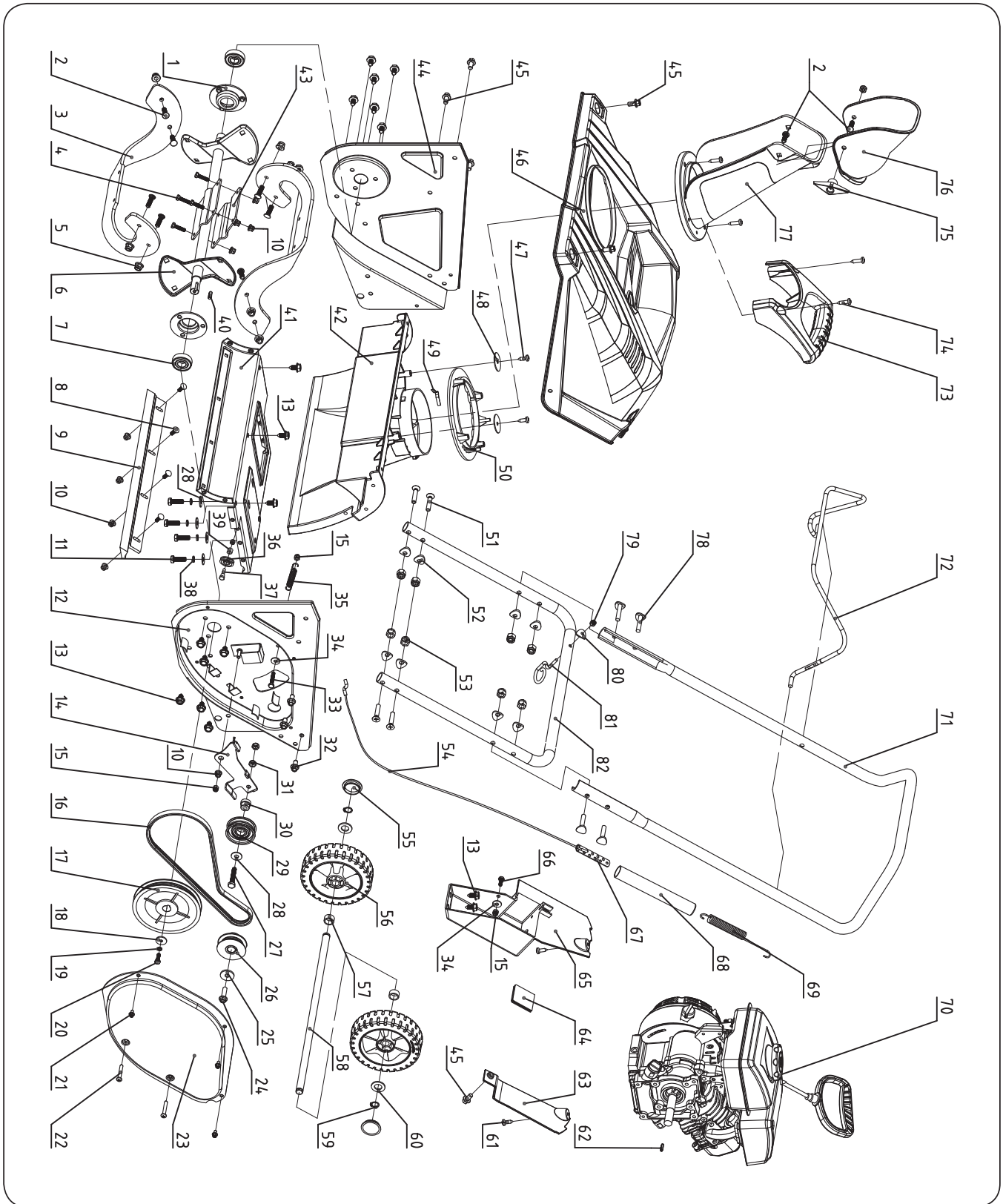

PARTS LIST

No.	Description	QTY.
1	Bearing Cup	2
2	Bolt M8x25	10
3	Rubber Auger	2
4	Bolt M6x25	4
5	Flange Locknut M8	9
6	Auger Shaft	1
7	Bearing 6203-2RS	2
8	Bolt M6x16	4
9	Scraper Blade	1
10	Flange Locknut M6	9
11	Bolt M8x25	4
12	Support Plate Left	1
13	Screw M8x16	21
14	Idler Pulley Bracket	1
15	Locknut M6	3
16	Belt	1
17	Auger Big Pulley	1
18	Big Flat Washer 6	1
19	Spring Washer 6	1
20	Bolt M6x20	1
21	Screw M5x12	3
22	Screw M6x40	2
23	Belt cover	1
24	Bolt 5/16	1
25	Big Flat Washer 8	1
26	Drive Pulley	1
27	Bolt M8x55	1
28	Big Washer 8	5
29	Drive Clutch Idler	1
30	Bushing	1
31	Locknut M8	2
32	Screw M6x16	2
33	Bolt M6x35	1
34	Big Washer 6	2
35	Spring	1
36	Cable Roller	1
37	Roller Shaft	1
38	Spring Washer 8	4

No.	Description	QTY.
39	Roller Bushing	1
40	Key A5x18	1
41	Support Base Plate	1
42	Chute Adapter	1
43	Auger Reinforcing Plate	1
44	Support Plate Right	1
45	Screw ST8x16	7
46	Shroud Assembly	1
47	Screw ST6.3x19	2
48	Retaining Washer	2
49	Lock-up Spring Plate	1
50	Chute Base	1
51	Screw M8x40	4
52	Arc Washer 8	8
53	Locknut M8	8
54	Clutch Cable	1
55	Wheel Cap	2
56	Wheel	2
57	Wheel Bushing	2
58	Wheel Axle	1
59	Circlip 14	2
60	Washer 14	2
61	Screw ST6.3x16	2
62	Key B4x6.5x18	1
63	Shroud Assembly Backplate	1
64	Rubber Plug	1
65	Electric Starter Bracket	1
66	Bolt M6x16	1
67	Adjuster Link	1
68	Spring Cover	1
69	Spring	1
70	Engine	1
71	Upper Handle	1
72	Auger Clutch Handle	1
73	Chute Handle	1
74	Screw ST6.3x25	4
75	Swing Knob	1
76	Chute Deflector	1

No.	Description	QTY.
77	Discharge Chute	1
78	Bolt M8x45	4
79	Thick Lock Nut M6	2

No.	Description	QTY.
80	Arc Washer 6	1
81	Recoil Start Handle Bracket	1
82	Lower Handle	1

Tame the Great Outdoors™

