

# 3060 Walk-in Bathtub 409 Value Series

*American Standard*



The American Standard 30" x 60" Gelcoat walk-in bath provides the maximum in therapeutic soaking pleasure with the largest water capacity in our product line. The full sized, contoured door with a low door threshold allows ease of entry and exit.

Fully equipped, the 409 Value Series—available only at Home Depot offers all the latest in safety and comfort features bundled together at one low cost and backed by a lifetime warranty on the door seal, a 10 year warranty on the tub shell and a 5 year warranty on all other components.

## **WHIRLPOOL MASSAGE**



A soothing and invigorating water jet massage system, the Whirlpool massage features an in-line heater and Legs-Only massage. Customize back and leg muscle therapies with 8 different water jets. The Whirlpool Spa is combined with all of the features of the Soaker Tub providing an enhanced therapeutic bathing experience.

## **AIR SPA MASSAGE**



Experience a soft and caressing all-over body massage powered by a single speed heated blower that releases thousands of air bubbles rising throughout the water from 21 different air jets. The automatic purge cycle helps keep the system running efficient and clean. The Air Spa is combined with all of the features of the Soaker Tub providing an enhanced therapeutic bathing experience.

## **COMBINATION SYSTEM**



Combines all of the features of the Soaker Tub, the Air Spa and the Whirlpool Massage Systems for the ultimate therapeutic bathing experience.

## **QUICK DRAIN® WATER REMOVAL SYSTEM**



Spend less time waiting with this patented innovation—that requires no additional plumbing, once activated it rapidly pumps the water out from within the tub, making it safe to open the door and exit the tub. Included in all systems.

# 3060.409 VALUE SERIES 30" x 60" WALK-IN BATH

## 3060.409.SXX Soaking Tub

- Available in White or Linen and in Left Hand or Right Hand Door/Drain Configuration
- Watertight door system with a lifetime warranty on the door seal
- Built-in chair height seat
- Polished chrome trim and cable driven waste and overflow
- Built-in safety bar and textured tub floor
- Patented Quick Drain® fast water removal system
- Premium tub faucet and handheld showering wand

## 3060.409.WXX Whirlpool Massage System

### Combines all of the features of the Soaking Tub, plus:

- 8 massage jets with variable flow
- Legs-only massage
- Whirlpool in-line heater

## 3060.409.AXX Air Spa System

### Combines all of the features of the Soaking Tub, plus:

- 21 seat and floor air injectors
- Single speed heated blower
- Automatic purge cycle

## 3060.409.CXX Combination System

### Combines all of the features of the Soaker Tub, the Whirlpool Massage and the Air Spa Systems for the ultimate therapeutic bathing experience

#### To Be Specified - Required:

- Drain Configuration: Left (L) or Right (R)
- Color: White (W) or Linen (L)

#### Options:

- Handshower Glide Bar: 9HSB
- 24 inch Grab Bar: 9GB-24
- Neck Rest: 9NR

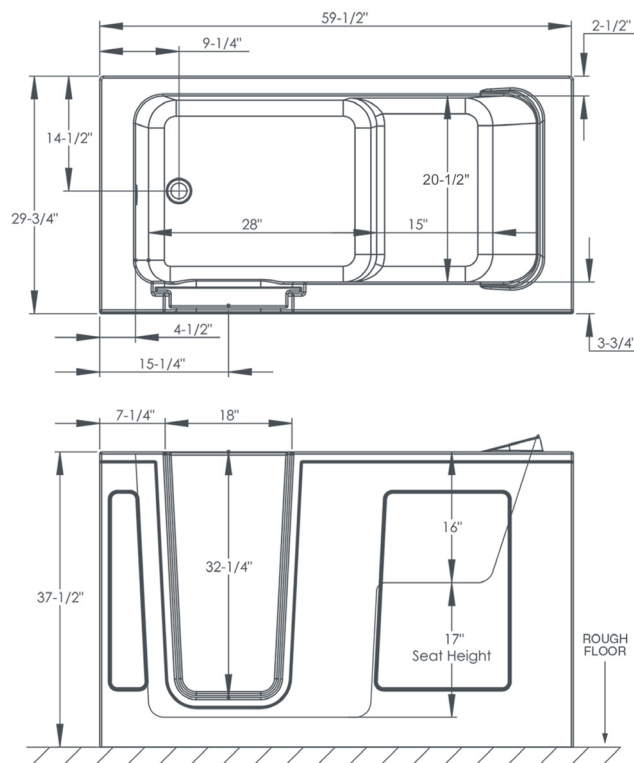

#### GENERAL SPECIFICATIONS FOR 3060.409.XXX WALK-IN BATHTUB

INSTALLED SIZE	_____ 60" x30" x37" (1524 x762 x940mm)
WEIGHT	_____ 150 lbs (68 Kg)
WEIGHT W/WATER	_____ 900 lbs (408 Kg)
OPERATING GALLON	_____ 75 Gal. (284L)
FLOOR LOADING	_____ 73 lbs/Sq Ft (275 Kg/Sq M)
(PROJECTED AREA) CUBE FT <sup>2</sup>	_____ 38.5



Designed to  
improve mobility  
& make life easier

**Notes:** The whirlpool heater is designed to maintain water temperature during operation. It will not heat cold water to desired bathing temperature. Tub is supported by the frame and five integrated adjustable feet, no additional support required. Refer to installation instructions supplied with tub for additional information. Provide suitable reinforcement to sub floor for all supports.

**Our products are in compliance with the following codes:** Uniform Plumbing Code UPC®; National Plumbing Code of Canada; International Plumbing Code IPC®

**Our products conform to the following standards:** ASME A112.19.7, ASME A112.19.15; CSA B45, CSA B45.5; CSA C22.2 No. 218.2; UL-1795; ANSI Z124.1.2

**Our products are listed with:** c ETL us

**IMPORTANT:** Dimensions of fixtures are nominal, may vary and are subject to change or cancellation. No responsibility is assumed for use of superseded or voided leaflet.