

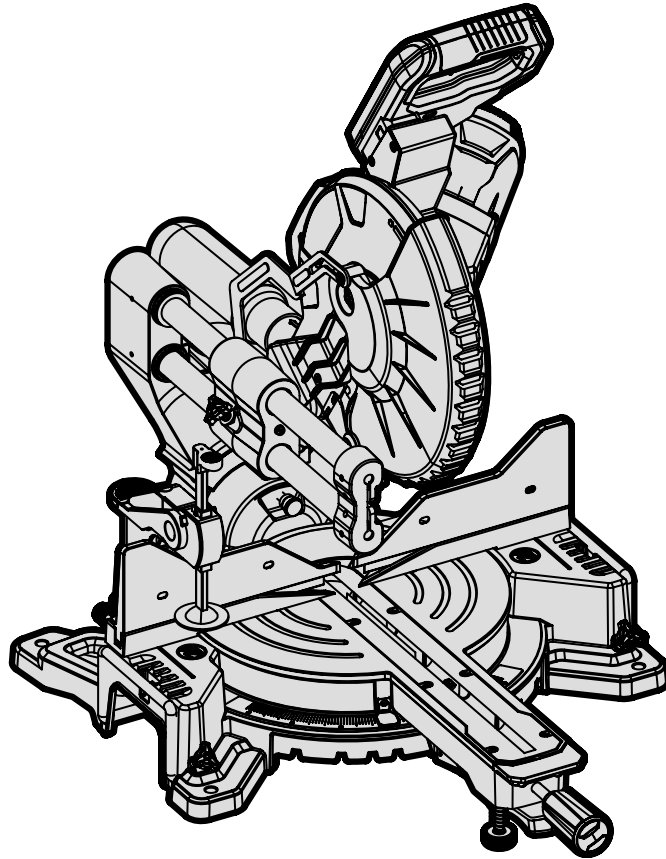

MODEL MM1015

10" DOUBLE BEVEL SLIDING COMPOUND MITER SAW

Instruction Manual



NEED HELP? CONTACT US!

Have product questions? Need technical support? Please feel free to contact us:

 **1-800-232-1195 (M-F 8AM-5PM CST)** |  **TECHSUPPORT@WENPRODUCTS.COM**

IMPORTANT: Your new tool has been engineered and manufactured to WEN's highest standards for dependability, ease of operation, and operator safety. When properly cared for, this product will supply you years of rugged, trouble-free performance. Pay close attention to the rules for safe operation, warnings, and cautions. If you use your tool properly and for its intended purpose, you will enjoy years of safe, reliable service.

For replacement parts and the most up-to-date instruction manuals, visit ***WENPRODUCTS.COM***

CONTENTS

WELCOME	3
Introduction	3
Specifications.....	3
SAFETY	4
General Safety Rules.....	4
Specific Rules for Your Miter Saw.....	6
Electrical Information.....	8
BEFORE OPERATING	9
Unpacking & Transportation	9
Know Your Miter Saw	10
Assembly & Adjustments.....	12
OPERATION & MAINTENANCE	19
Operation	19
Maintenance	21
Troubleshooting Guide.....	23
Exploded View & Parts List.....	25
Warranty Statement.....	34

To purchase accessories for your tool, visit ***WENPRODUCTS.COM***

Collapsible Rolling Miter Saw Stand (Model MSA330)

750-Pound Capacity Miter Saw Stand (Model MSA750, MSA750T)

Multi-Purpose Rolling Planer and Miter Saw Tool Stand (Model MSA658T)

INTRODUCTION

Thanks for purchasing the WEN Miter Saw. We know you are excited to put your tool to work, but first, please take a moment to read through the manual. Safe operation of this tool requires that you read and understand this operator's manual and all the labels affixed to the tool. This manual provides information regarding potential safety concerns, as well as helpful assembly and operating instructions for your tool.

⚠ SAFETY ALERT SYMBOL: Indicates danger, warning, or caution. The safety symbols and the explanations with them deserve your careful attention and understanding. Always follow the safety precautions to reduce the risk of fire, electric shock or personal injury. However, please note that these instructions and warnings are not substitutes for proper accident prevention measures.

NOTE: The following safety information is not meant to cover all possible conditions and situations that may occur. WEN reserves the right to change this product and specifications at any time without prior notice.

At WEN, we are continuously improving our products. If you find that your tool does not exactly match this manual, please visit wenproducts.com for the most up-to-date manual or contact our customer service at **1-800-232-1195**.

Keep this manual available to all users during the entire life of the tool and review it frequently to maximize safety for both yourself and others.

SPECIFICATIONS

Model Number	MM1015	
Motor	120V, 60 Hz, 15A	
No-Load Speed	5000 RPM	
Blade Model Number	BL1040	
Blade Size	10 Inches	
Arbor Size	5/8 Inch (16mm)	
Kerf & Teeth	2.4mm, 40T	
Miter Table Angles	0° - 49° Left and Right	
Bevel Cut Angles	0° - 45° Left and Right	
Positive Miter Stops	0, 15, 22.5, 31.6, and 45, Left and Right	
Cutting Capacity	0° Miter, 0° Bevel	12 in. x 3.75 in.
	45° Miter, 0° Bevel	8.5 in. x 3.75 in.
	0° Miter, 45° Bevel	12 in. x 2.63 in.
	45° Miter, 45° Bevel	8.5 in. x 2.63 in.
Dust Port Adapter (Inner Diameter)	1.4 Inches (35mm)	
Weight	40 Pounds	
Product Dimensions	29.5 in. x 20.4 in. x 15.9 in.	

GENERAL SAFETY RULES

⚠ WARNING! Read all safety warnings and all instructions. Failure to follow the warnings and instructions may result in electric shock, fire and/or serious injury.

Safety is a combination of common sense, staying alert and knowing how your item works. The term “power tool” in the warnings refers to your mains-operated (corded) power tool or battery-operated (cordless) power tool.

SAVE THESE SAFETY INSTRUCTIONS.

WORK AREA SAFETY

- 1. Keep work area clean and well lit.** Cluttered or dark areas invite accidents.
- 2. Do not operate power tools in explosive atmospheres, such as in the presence of flammable liquids, gases or dust.** Power tools create sparks which may ignite the dust or fumes.
- 3. Keep children and bystanders away while operating a power tool.** Distractions can cause you to lose control.

ELECTRICAL SAFETY

- 1. Power tool plugs must match the outlet. Never modify the plug in any way. Do not use any adapter plugs with earthed (grounded) power tools.** Unmodified plugs and matching outlets will reduce risk of electric shock.
- 2. Avoid body contact with earthed or grounded surfaces such as pipes, radiators, ranges and refrigerators.** There is an increased risk of electric shock if your body is earthed or grounded.
- 3. Do not expose power tools to rain or wet conditions.** Water entering a power tool will increase the risk of electric shock.
- 4. Do not abuse the cord. Never use the cord for carrying, pulling or unplugging the power tool. Keep cord away from heat, oil, sharp edges or moving parts.** Damaged or entangled cords increase the risk of electric shock.
- 5. When operating a power tool outdoors, use an extension cord suitable for outdoor use.** Use of a cord suitable for outdoor use reduces the risk of electric shock.

6. If operating a power tool in a damp location is unavoidable, use a ground fault circuit interrupter (GFCI) protected supply. Use of a GFCI reduces the risk of electric shock.

PERSONAL SAFETY

- 1. Stay alert, watch what you are doing and use common sense when operating a power tool. Do not use a power tool while you are tired or under the influence of drugs, alcohol or medication.** A moment of inattention while operating power tools may result in serious personal injury.
- 2. Use personal protective equipment. Always wear eye protection.** Protective equipment such as a respiratory mask, non-skid safety shoes and hearing protection used for appropriate conditions will reduce the risk of personal injury.
- 3. Prevent unintentional starting. Ensure the switch is in the off-position before connecting to power source and/or battery pack, picking up or carrying the tool.** Carrying power tools with your finger on the switch or energizing power tools that have the switch on invites accidents.
- 4. Remove any adjusting key or wrench before turning the power tool on.** A wrench or a key left attached to a rotating part of the power tool may result in personal injury.
- 5. Do not overreach. Keep proper footing and balance at all times.** This enables better control of the power tool in unexpected situations.
- 6. Dress properly. Do not wear loose clothing or jewelry. Keep your hair and clothing away from moving parts.** Loose clothes, jewelry or long hair can be caught in moving parts.

GENERAL SAFETY RULES

 **WARNING!** Read all safety warnings and all instructions. Failure to follow the warnings and instructions may result in electric shock, fire and/or serious injury.

Safety is a combination of common sense, staying alert and knowing how your item works. The term “power tool” in the warnings refers to your mains-operated (corded) power tool or battery-operated (cordless) power tool.

SAVE THESE SAFETY INSTRUCTIONS.

7. If devices are provided for the connection of dust extraction and collection facilities, ensure these are connected and properly used. Use of dust collection can reduce dust-related hazards.

POWER TOOL USE AND CARE

1. Do not force the power tool. Use the correct power tool for your application. The correct power tool will do the job better and safer at the rate for which it was designed.

2. Do not use the power tool if the switch does not turn it on and off. Any power tool that cannot be controlled with the switch is dangerous and must be repaired.

3. Disconnect the plug from the power source and/or the battery pack from the power tool before making any adjustments, changing accessories, or storing power tools. Such preventive safety measures reduce the risk of starting the power tool accidentally.

4. Store idle power tools out of the reach of children and do not allow persons unfamiliar with the power tool or these instructions to operate the power tool. Power tools are dangerous in the hands of untrained users.

5. Maintain power tools. Check for misalignment or binding of moving parts, breakage of parts and any other condition that may affect the power tool's operation. If damaged, have the power tool repaired before use. Many accidents are caused by poorly maintained power tools.

6. Keep cutting tools sharp and clean. Properly maintained cutting tools with sharp cutting edges are less likely to bind and are easier to control.

7. Use the power tool, accessories and tool bits, etc. in accordance with these instructions, taking into account the working conditions and the work to be performed. Use of the power tool for operations different from those intended could result in a hazardous situation.

8. Use clamps to secure your workpiece to a stable surface. Holding a workpiece by hand or using your body to support it may lead to loss of control.

9. KEEP GUARDS IN PLACE and in working order.

SERVICE

1. Have your power tool serviced by a qualified repair person using only identical replacement parts. This will ensure that the safety of the power tool is maintained.

CALIFORNIA PROPOSITION 65 WARNING

Some dust created by power sanding, sawing, grinding, drilling, and other construction activities may contain chemicals, including lead, known to the State of California to cause cancer, birth defects, or other reproductive harm. Wash hands after handling. Some examples of these chemicals are:

- Lead from lead-based paints.
- Crystalline silica from bricks, cement, and other masonry products.
- Arsenic and chromium from chemically treated lumber.

Your risk from these exposures varies depending on how often you do this type of work. To reduce your exposure to these chemicals, work in a well-ventilated area with approved safety equipment such as dust masks specially designed to filter out microscopic particles.

SPECIFIC RULES FOR YOUR MITER SAW

 **WARNING!** Do not operate the power tool until you have read and understood the following instructions and the warning labels.

SAW BLADE SAFETY

1. Always wear protective gloves when handling saw blades.

2. Only use blades with correct size and type for both your miter saw and your workpiece.

- The rated diameter of the saw blade is 10 inches with a 5/8 inch arbor.
- The no-load speed of the Miter Saw is 5000 RPM. The maximum permissible speed of your saw blade should always be higher than the no-load rotational speed of the saw.

3. Never use damaged or deformed saw blades. Only use sharp blades.

4. Install the saw blade in the correct orientation indicated in the instructions (see "Changing The Saw Blade").

5. Keep hands out of path of saw blade. Never use your hands to remove sawdust, chips or workpieces near the saw blade or the cutting path of the saw.

6. Never reach around the saw blade or reach in back of the saw blade.

7. Do not use blades made from high-speed steel, abrasive blades, metal-cutting blades or masonry-cutting blades. The guards of this saw are not designed to protect against the failure of such blades.

8. The use of accessories or attachments not recommended by the manufacturer may result in a risk of personal injury.

PERSONAL SAFETY

1. Operate in a well ventilated area. Keep the floor area around the miter saw level and free of slippery substances or other tripping hazards.

2. Wear ANSI-approved safety goggles to protect your eyes from sparks and sawdust. Use hearing protection to protect yourself from hearing loss.

3. People with pacemakers should consult their physician(s) before use. Electromagnetic fields in close proximity to pacemakers could cause pacemaker interference or pacemaker failure.

4. Wear work gloves when handling saw blades. DO NOT wear gloves while operating the saw.

5. Sawdust is harmful to your health. Use NIOSH-approved dust masks or other respiratory protection during operation and cleaning.

6. Always turn off and unplug the miter saw before making any adjustments or repair tasks. Never adjust the miter saw or the workpiece while the saw is running.

7. Never use damaged or incorrect blade flanges or bolt. The blade flanges and bolt were specially designed for your saw, for optimum performance and safety of operation.

8. Do not use to cut metal, logs, tree limbs, or uneven lumber. Inspect the workpiece and remove all nails and other embedded objects prior to starting work.

9. Wet lumber, green (unseasoned) lumber, and pressure treated lumber all have an increased potential for kickback and should only be cut with a blade specifically designed for that lumber type. Wear a NIOSH-approved respirator and have appropriate ventilation whenever cutting pressure treated lumber.

PREPARING THE MITER SAW

When transporting the miter saw, carry it by either the handle or the base. Never carry the device by its guards or its accessories. Make sure that the blade is fully covered by the blade cover and not exposed. Lock the miter head in place and lock the slides before transporting the saw.

1. Examine the miter saw for any damaged or missing parts. Replace or repair damaged parts before operation. Periodically check that all nuts, bolts and other fasteners are properly tightened.

SPECIFIC RULES FOR YOUR MITER SAW

SECURE YOUR WORKPIECE

1. Never hand-hold a workpiece that is too small to be clamped, as it can be launched away and cause injury. Use proper support and guides to secure the small workpiece.

DURING CUTTING OPERATIONS

1. Always stand to one side when operating the saw. Never have any part of the body in line with the path of the saw. Never hold a workpiece in your hand or across your legs while cutting.

2. Ensure hands are away from the cutting area and blade. Keep one hand on the operating handle, and the other out away from the blade and its path.

3. Feed work into the blade against the direction of rotation of the blade only.

4. If you are interrupted when operating the saw, complete the process and switch the saw off before looking up.

5. Power tools must always be held by the insulated gripping surfaces when performing an operation, ensuring protection if the cutting tool makes contact with its own cord or hidden wiring. Contact with a 'live' wire will make exposed metal parts of the power tool 'live' and shock the operator if the insulated gripping surfaces are not used.

6. Do not use the miter saw unless all guards are in place. Do not operate with any guard disabled, damaged, or removed. Moving guards must move freely and close instantly.

7. Turn on the miter saw and let it reach full speed, then slowly slide the saw into the workpiece. This will help produce safer and cleaner cuts.

8. Always push the saw blade forwards and away from you. Do not pull the saw towards you, or move the saw backwards while cutting. Do not apply any sideways or twisting force to the blade while cutting.

9. Never cut more than one piece at a time. Do not stack workpieces together. Do not attempt to cut material thicker than specified on page 2 of this manual. Adjust the cutting depth to the thickness of the workpiece (less than a full tooth of the blade should be visible below the workpiece).

10. If a cut does not extend to the edge of the workpiece, or if the blade binds in the cut, allow the blade to come to a complete stop and lift the saw out of the workpiece.

11. Turn off the tool and wait for the saw blade to stop before moving workpiece or changing settings. Do not slow or stop a blade with a piece of wood. Let the blade come to rest naturally. Do not attempt to free a jammed blade while the machine is still running and connected to power.

12. Always raise the blade to be covered by the blade guard after use.

ELECTRICAL INFORMATION

DOUBLE-INSULATED TOOLS

The tool's electrical system is double-insulated where two systems of insulation are provided. This eliminates the need for the usual three-wire grounded power cord. Double-insulated tools do not need to be grounded, nor should a means for grounding be added to the product. All exposed metal parts are isolated from the internal metal motor components with protecting insulation.

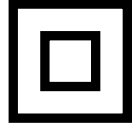

IMPORTANT: Servicing a double-insulated product requires extreme care and knowledge of the system, and should be done only by qualified service personnel using identical replacement parts. Always use original factory replacement parts when servicing.

1. Polarized Plugs. To reduce the risk of electric shock, this equipment has a polarized plug (one blade is wider than the other). This plug will fit in a polarized outlet only one way. If the plug does not fit fully in the outlet, reverse the plug. If it still does not fit, contact a qualified electrician to install a proper outlet. Do not modify the machine plug or the extension cord in any way.

2. Ground fault circuit interrupter protection (GFCI) should be provided on the circuit or outlet used for this power tool to reduce the risk of electric shock.

3. Service and repair. To avoid danger, electrical appliances must only be repaired by a qualified service technician using original replacement parts.

GUIDELINES AND RECOMMENDATIONS FOR EXTENSION CORDS

When using an extension cord, be sure to use one heavy enough to carry the current your product will draw. An undersized cord will cause a drop in line voltage, resulting in loss of power and overheating. The table below shows the correct size to be used according to cord length and ampere rating. When in doubt, use a heavier cord. The smaller the gauge number, the heavier the cord.

AMPERAGE	REQUIRED GAUGE FOR EXTENSION CORDS			
	25 ft.	50 ft.	100 ft.	150 ft.
15A	14 gauge	12 gauge	No Recommended	No Recommended

1. Examine extension cord before use. Make sure your extension cord is properly wired and in good condition. Always replace a damaged extension cord or have it repaired by a qualified person before using it.

2. Do not abuse extension cord. Do not pull on cord to disconnect from receptacle; always disconnect by pulling on plug. Disconnect the extension cord from the receptacle before disconnecting the product from the extension cord. Protect your extension cords from sharp objects, excessive heat and damp/wet areas.

3. Use a separate electrical circuit for your tool. This circuit must not be less than a 12-gauge wire and should be protected with a 15A time-delayed fuse. Before connecting the motor to the power line, make sure the switch is in the OFF position and the electric current is rated the same as the current stamped on the motor nameplate. Running at a lower voltage will damage the motor.

UNPACKING & TRANSPORTATION

⚠ WARNING! Do not plug in or turn on the tool until it is fully assembled according to the instructions. Failure to follow the safety instructions may result in serious personal injury.

UNPACKING

With the help of a friend or trustworthy foe, carefully remove the miter saw from the packaging. Make sure to take out all contents and accessories. Do not discard the packaging until everything is removed. Check the packing list below to make sure you have all of the parts and accessories. If any part is missing or broken, please contact our customer service at **1-800-232-1195** (M-F 8-5 CST), or email **techsupport@wenproducts.com**.

PACKING LIST

Components

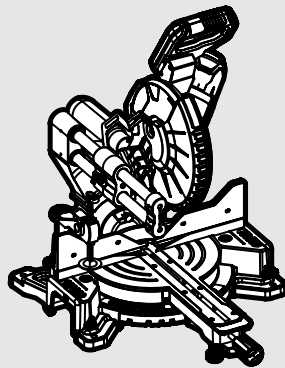

Miter Saw (1)

Accessories & Tools



6mm Hex Wrench /
Cross Screwdriver (1)

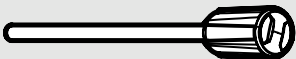

Miter Lock Handle (1)

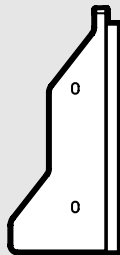

Left Adjustable
Fence (1)

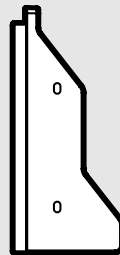

Right Adjustable
Fence (1)

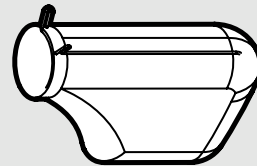

Dust Bag (1)

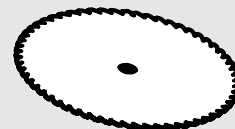

Blade (1)

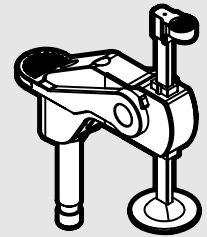

Wood Clamp (1)

TRANSPORTING

Before transporting your miter saw, make sure saw arm is locked down, the miter table is locked in position and the slide lock knob is tightened. Only lift the saw by the carrying handle located on top of the motor housing. Do not lift the saw using the guards or the operating handle.

KNOW YOUR MITER SAW

TOOL PURPOSE

Miter saws allow you to easily make cuts at a variety of angles. Refer to the following diagrams to become familiarized with all the parts and controls of your miter saw. The components will be referred to later in the manual for assembly and operation instructions.

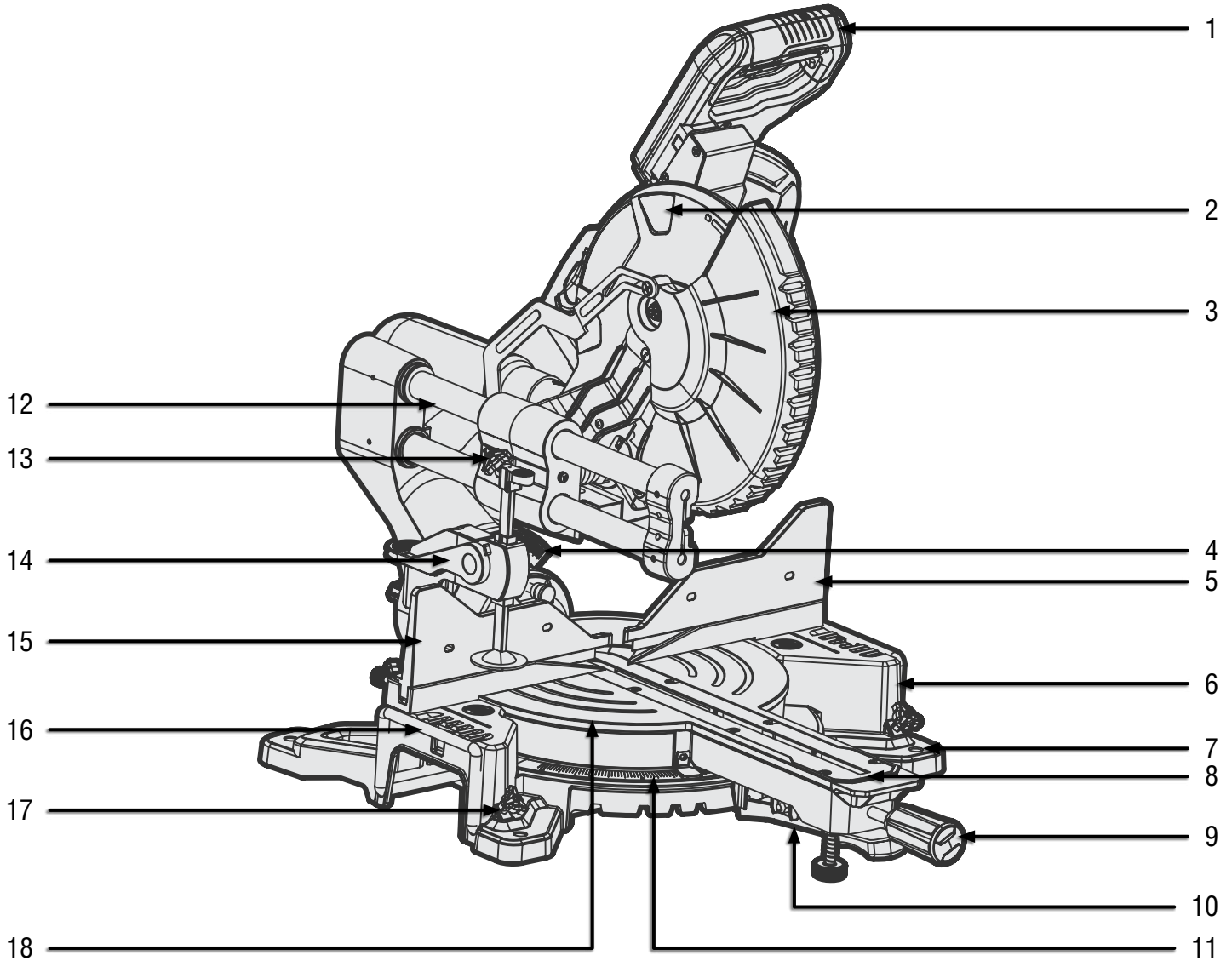

- 1. Operating Handle
- 2. Upper Blade Guard
- 3. Lower Blade Guard
- 4. Bevel Scale
- 5. Right Adjustable Fence
- 6. Base

- 7. Mounting Hole
- 8. Table Insert
- 9. Miter Lock Knob
- 10. Miter Angle Adjustment Lever
- 11. Miter Scale
- 12. Sliding Bar

- 13. Sliding Bar Lock Knob
- 14. Workpiece Clamp
- 15. Left Adjustable Fence
- 16. Workpiece Support Bar
- 17. Support Bar Lock Knob
- 18. Miter Table

KNOW YOUR MITER SAW

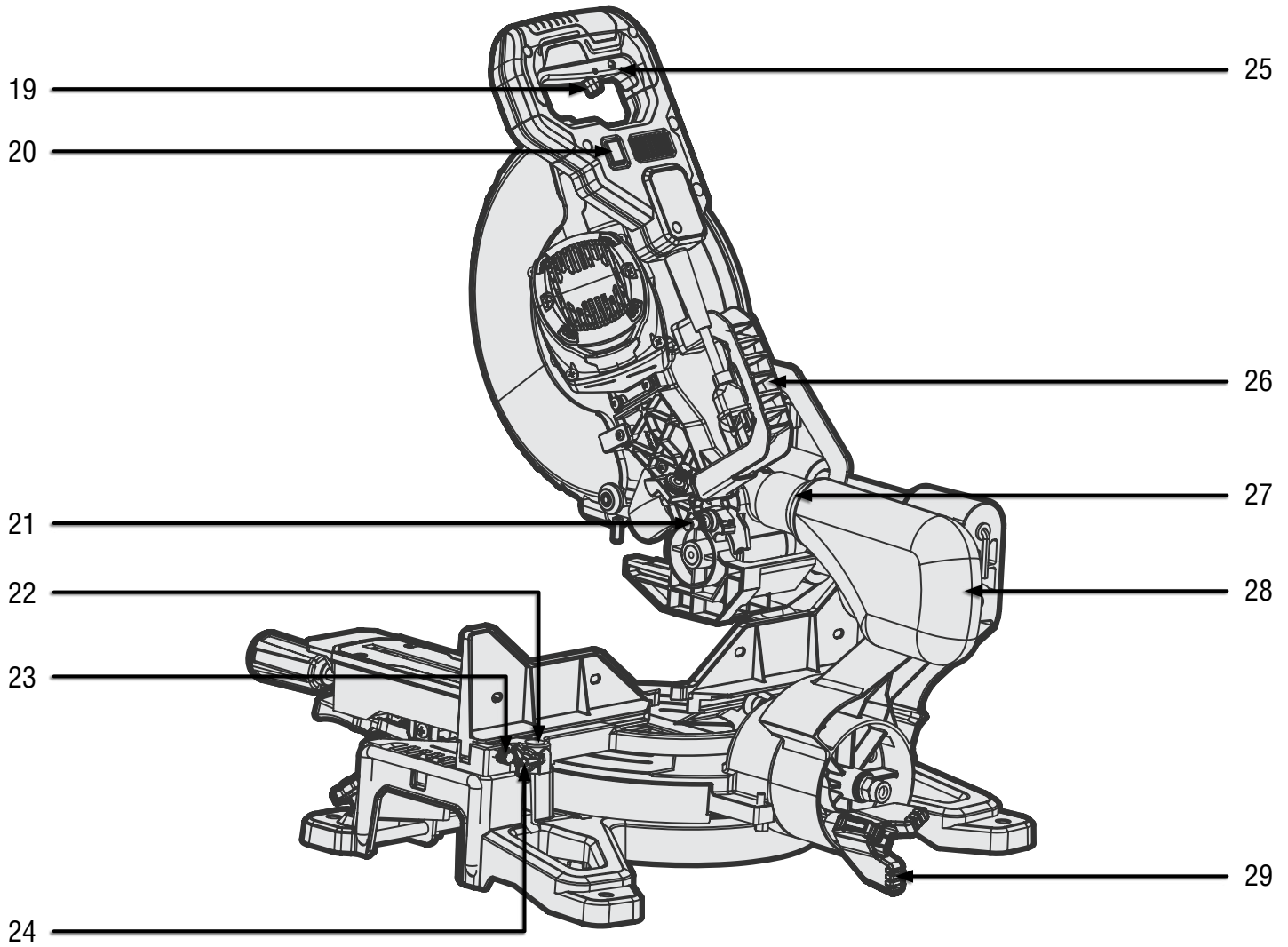

- 19. Power Switch Lock
- 20. LED Power Switch
- 21. Release Bolt
- 22. Workpiece Clamp Holder
- 23. Fence Locking Knob
- 24. Workpiece Clamp Lock Knob

- 25. Power Switch
- 26. Carrying Handle
- 27. Dust Port
- 28. Dust Bag
- 29. Bevel Locking Knob

ASSEMBLY & ADJUSTMENTS

⚠ WARNING! Do not plug in or turn on the tool until it is fully assembled according to the instructions. Read through and become familiarized with the following procedures of handling and adjusting your tool. Failure to follow the safety instructions may result in serious personal injury.

INSTALLING THE MITER LOCK KNOB

1. Screw the miter lock knob (Fig. 1 - 1) into the miter lock until hand-tight. Do not overtighten; this could damage the miter lock.

INSTALLING THE BLADE

1. The blade is packaged in a white cardboard sleeve and is packed with a protective rubber edging. Remove the blade from its packaging and rubber sleeve, being careful not to scrape yourself along the blade edge.

2. Lift the saw arm to the upper position and lock it in place. Raise the lower blade guard (Fig. A - 1) out of the way and hold it up.

3. Firmly press down the saw spindle lock (Fig. A - 2) below the operating handle and hold it in. Use the included 6mm hex wrench to turn the arbor bolt clockwise and remove it (the bolt is left-hand threaded) (Fig. A - 3). Remove the washer and outer flange. Make sure the inner flange stays in place on the arbor.

4. Place the blade on the arbor insert and spindle.

IMPORTANT: Make sure the blade's rotation arrow points in the same direction as the rotation arrow on the upper blade guard.

5. Reinstall the outer flange, washer, and arbor bolt. Hold down the spindle lock and tighten the arbor bolt with the hex wrench, turning it counterclockwise. Release the spindle lock.

6. Allow the lower blade guard to return back into position.

IMPORTANT: Carefully rotate the saw blade and make sure that it does not wobble. Lower the saw arm and check that the blade does not contact the kerf board with the saw at 0° and 45° bevel angles. Make sure the lower blade guard operates properly before using the saw.

GUARD OPERATION

NOTE: Keep hands clear of the blade when the operating handle is lowered. Do not interfere with the proper movement of the blade guard.

When the handle is lowered, the blade guard raises automatically. **When the handle is raised**, the blade guard returns to its safety position, covering the blade.

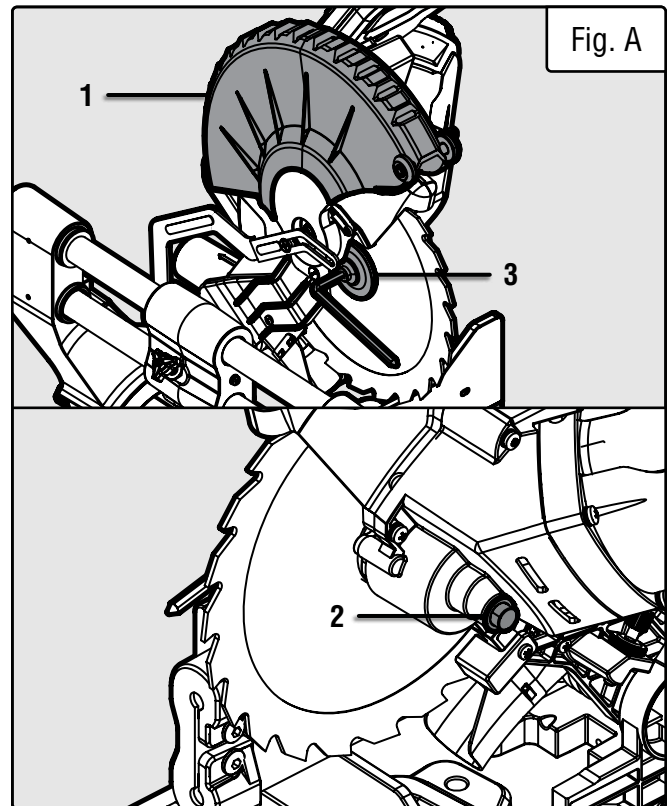
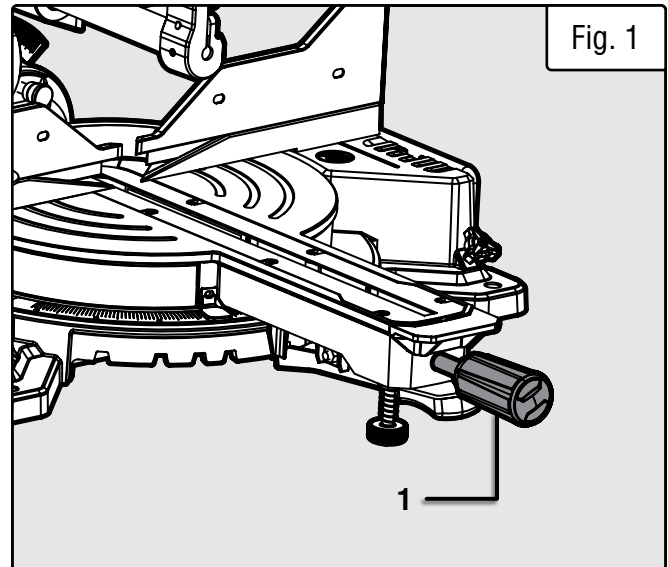

ASSEMBLY & ADJUSTMENTS

RAISING/LOWERING THE SAW ARM

The saw arm needs to be raised up before operation and locked down for transporting and storing.

To raise saw arm from the lower position:

1. Holding operating handle (Fig. 2 - 1), lightly press down on the saw arm and pull out the release bolt (Fig. 2 - 2).
2. Slowly raise the saw arm to the upper position.

To lower saw arm from the upper position:

1. Holding the operating handle (Fig. 2 - 1), pull out the release knob (Fig. 2 - 2).
2. Slowly lower the saw arm to the lower position and push the release bolt into the hole.

ADJUSTING THE BEVEL ANGLE

The saw arm can bevel from 0° to 45° to the left and right.

1. As viewed from the rear of the saw, loosen the bevel lock knob (Fig. 2 - 3) by turning it counterclockwise.
2. The miter saw is equipped with a bevel pin (Fig. B - 1) that provides positive bevel angle stops. With the bevel pin fully pushed in, the saw head is free to bevel up to 45° to the left. To bevel to the right, bevel the head slightly to the left and pull out the pin. To freely bevel the head in either direction, fully pull out the bevel pin.
3. Tilt the saw arm until the bevel angle indicator points to the desired angle on the bevel scale (Fig. 3 - 1).
4. The bevel pin has depth steps for different positive stop configurations. Pull out the pin one step and the pin has a positive stop 19° to the right. Pull out the pin two steps and the pin has a positive stop at 36° to the right. Fully pull out the pin to freely bevel the saw in either direction.

NOTE: If the bevel pin is stuck, slightly bevel the saw head in opposite direction that you are trying to bevel and pull out the pin.

5. Tighten the bevel lock knob by turning it clockwise. Be sure to tighten firmly without over-tightening.

SETTING UP ARM SLIDE

The saw arm can be adjusted to different lengths using the slide bar, and can slide back and forth when cross-cutting.

For sliding cuts: Loosen the sliding bar lock knob (Fig. B - 2) and slide the saw arm to desired position.

For non-sliding cuts and transportation: Tighten the sliding bar lock knob (Fig. B - 2) for non-sliding operations and before transporting the miter saw.

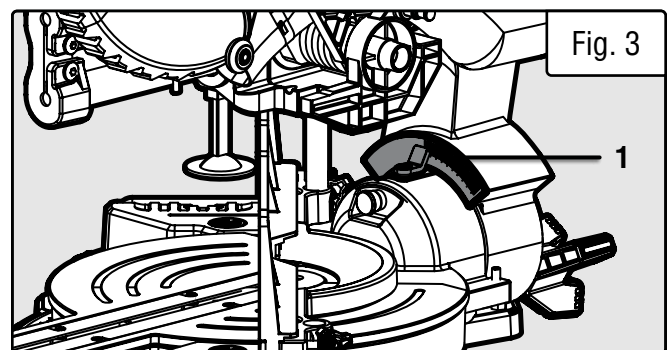
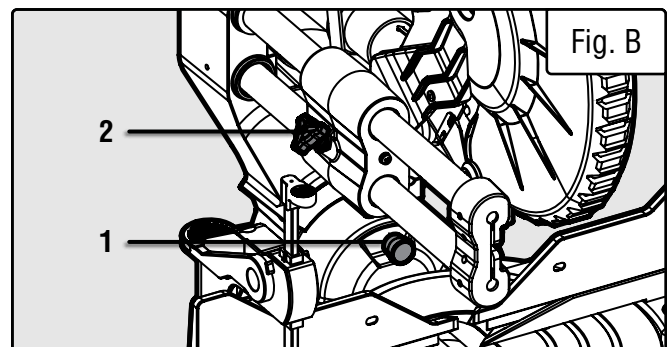
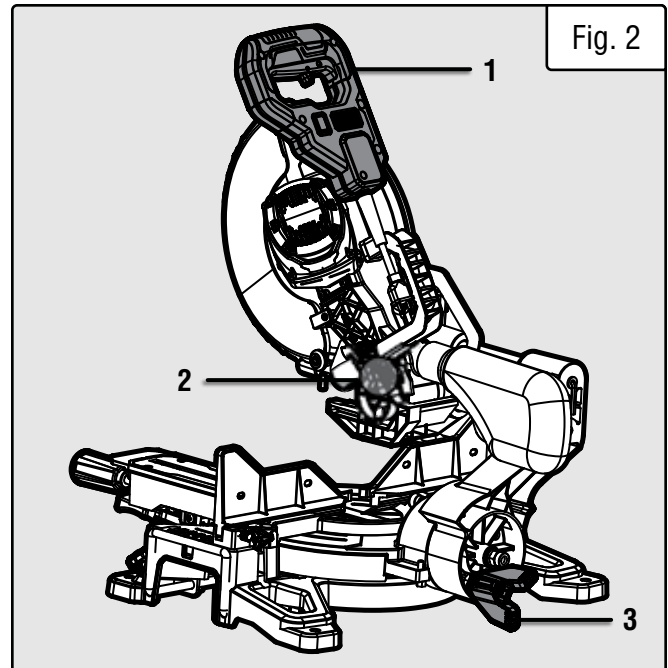

ASSEMBLY & ADJUSTMENTS

ADJUSTING THE MITER ANGLE

The miter table can be adjusted from 0° to 49° to the left and 0° to 45° to the right to create miter cuts.

1. Loosen the miter lock knob (Fig. 4 - 1) by turning it one or two turns counterclockwise.
2. Pull up on the miter angle adjustment lever (Fig. 4 - 2) to unlock the table. While holding the miter angle adjustment lever up, adjust the table to the desired angle. The miter scale indicator (Fig. 4 - 3) will point towards the selected angle. To make micro adjustments to a specific angle, rotate the table while pulling up on the miter stop lever. The miter table has positive stops at 0°, 15°, 22.5°, 31.6°, and 45° in both directions for quick adjustments.
3. After selecting your miter angle, release the miter stop lever and tighten the miter lock knob (Fig. 4 - 1) by turning it clockwise to lock the table in place.

WARNING! Be sure the miter table is locked in place before making a cut. Failure to do so can cause the table to move during the cut, which could result in serious personal injury.

INSTALLING THE CLAMP ASSEMBLY

The clamp comes pre-assembled and can be mounted on the left or right side of the saw depending on the cutting task at hand.

1. Locate the hole for the clamp on the left or right side of the miter saw behind the fence (Fig. 5 - Circles). Insert the clamp assembly (Fig. 5 - 1) into the hole on the desired side.
2. Secure the clamp into place by tightening the clamp lock knob.

NOTE: Check that the clamp won't interfere with the blade travel before operating the saw.

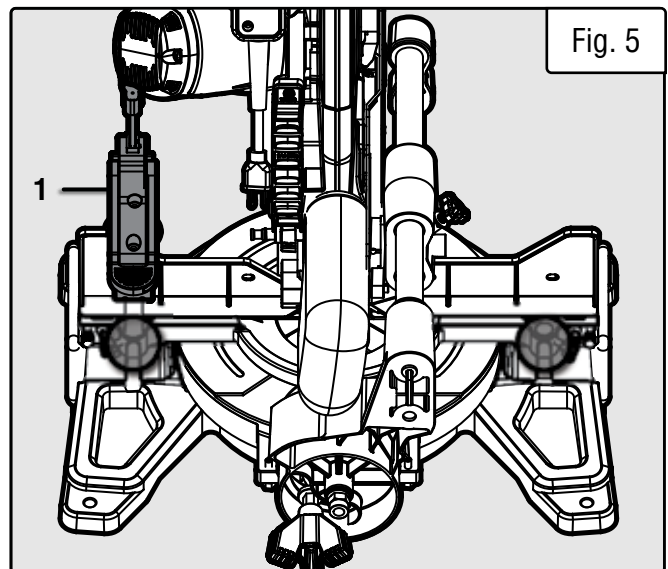
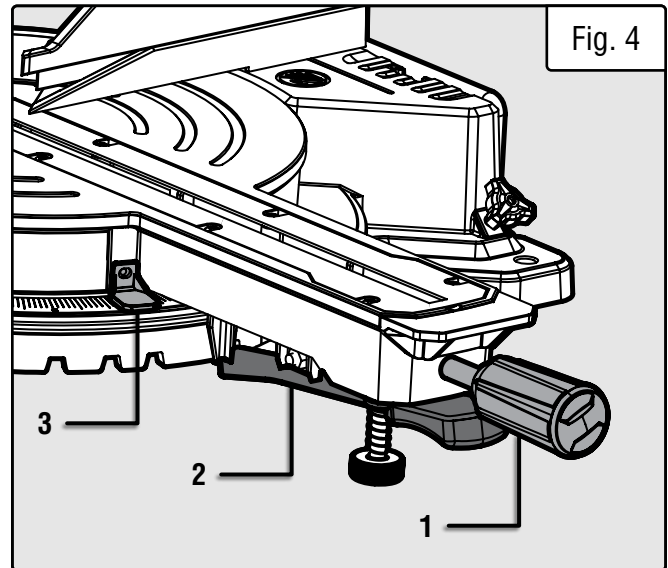

ASSEMBLY & ADJUSTMENTS

BENCH MOUNTING

The miter saw has four holes on the base for bench mounting (Fig. 6). Mount and fix the saw to a level, horizontal bench, worktable, or miter saw stand (compatible with WEN Models MSA330 and MSA750) using four bolts and nuts (not included).

If desired, you can mount the saw to a piece of 1/2 inch or thicker plywood which can then be clamped to your work bench or moved to other jobsites and reclamped.

CAUTION! Make sure that the mounting surface is not warped. Uneven surfaces can cause binding and inaccurate sawing.

INSTALLING THE DUST COLLECTION BAG

The dust collection bag should be used at all times. Follow the instructions below to install the bag.

1. Locate the dust port on the back of the miter saw (Fig. 7 - 1).
2. Squeeze the metal clip on the dust collection bag (Fig. 7 - 2) to open the mouth of the bag. Slip the mouth of the dust collection bag over the dust port and release the clip to secure the bag to the outlet.
3. Open the zipper on the bottom of the bag to empty. For efficient operation, empty the dust bag when half full to allow for better air flow through the bag.
4. If desired, use the included dust port adapter to connect to a dust extraction system. If needed, use a hose clamp to tightly clamp the dust hose to the adapter.

SQUARING THE FENCE WITH THE BLADE

To make accurate cuts, the fence must be perpendicular to the saw blade.

1. Lower the saw arm down to the lower position and lock the release bolt (Fig. 2 - 2).
2. Slide the saw arm to the back and tighten the slide lock knob (Fig. 3 - 2).
3. Set the miter table indicator (p. 15, Fig. 8 - 1) to 0° and tighten the miter lock knob. Place a combination square (not included) against the fence and alongside the saw blade (should be in contact with the surface of the blade, not the teeth).

Instructions continue on the next page.

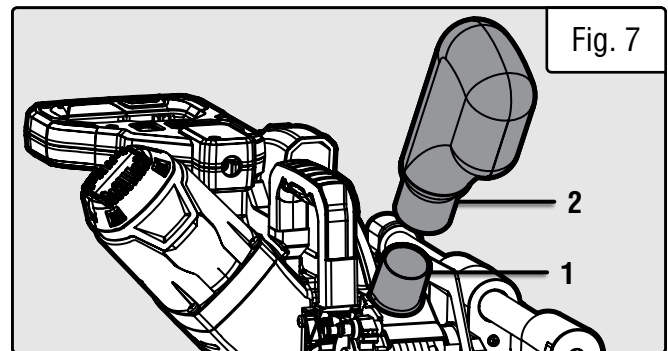
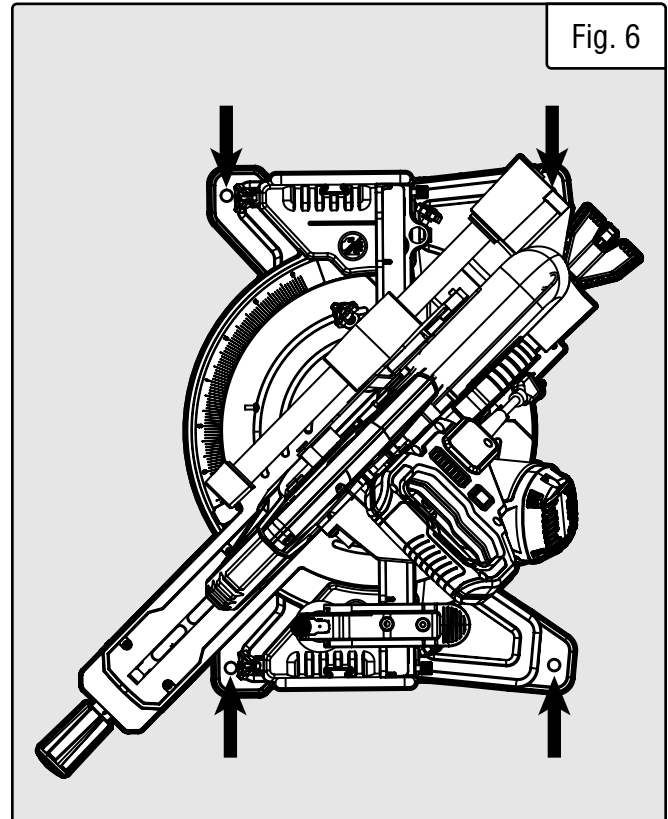

ASSEMBLY & ADJUSTMENTS

6. Slightly loosen the two fence adjusting bolts on the back of the fence (Fig. 8 - Circles) with the included hex wrench. Adjust the fence position until it is 90° with the blade. Tighten the four bolts to secure the fence.

7. Make a test cut. Repeat step 4 until your test cut is accurate.

SETTING THE MITER SCALE INDICATOR

1. Loosen the screw (Fig. 9 - 1) holding the miter scale indicator.

2. Adjust the direction of the indicator (Fig. 9 - 2) so that it accurately points to 0° on the miter scale. Tighten the screw.

SQUARING THE TABLE WITH THE BLADE

To make accurate cuts, the table must be perpendicular to the saw blade.

1. Lower the saw arm down to the lower position and lock the release bolt (Fig. 2 - 2).

2. Slide the saw arm to the back and tighten the slide lock knob. See section titled,

3. Set the miter scale indicator (Fig. 9 - 2) to 0° and tighten the miter lock knob. Set the bevel angle indicator to 0° (Fig. 10 - 1) and tighten the bevel lock knob (Fig. 2 - 3).

4. Place a combination square (not included) against the table and alongside the saw blade (should be in contact with the surface of the blade, not the teeth). Wearing work gloves, rotate the blade by hand and check the blade-to-table alignment at several points. The edge of the combination square and the saw blade should be parallel. If the saw blade does not lay flush against the combination square, follow steps 5 & 6 below.

5. Adjust the zero stop screw (Fig. 10 - 2) until the table is 90° with the blade. Tighten the zero stop lock nut to secure the blade.

6. Make a test cut. Repeat step 5 until your test cut is accurate.

NOTE: To adjust the 45° bevel stop screw, loosen the bevel adjustment nut (Fig. 10 - 3) and turn the bevel adjustment screw (Fig. 10 - 4) using a hex wrench. Turn counterclockwise to increase the bevel and clockwise to decrease the bevel. Tighten the nut after adjustment.

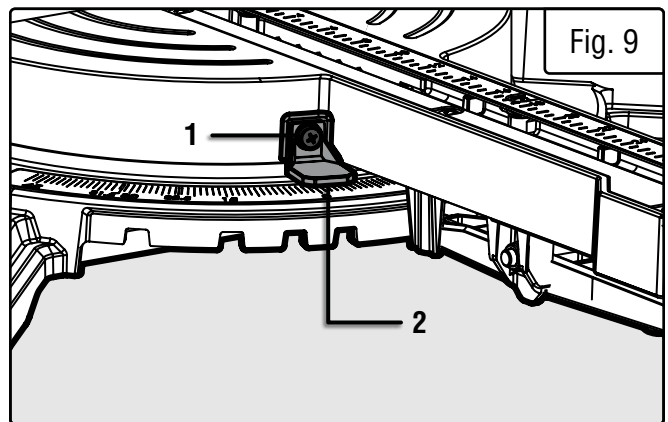
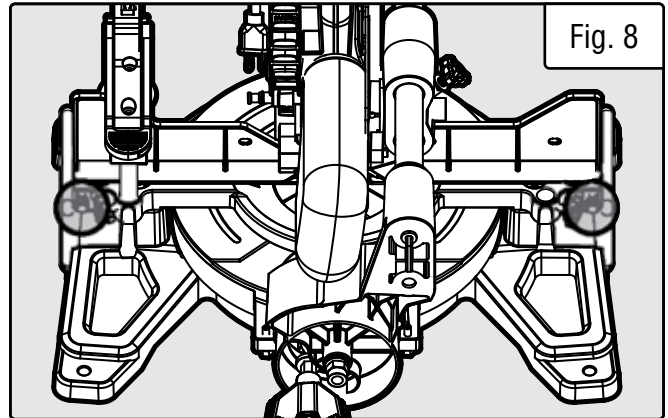

⚠ WARNING: To prevent serious injury, after making any adjustments to the cutting angle, make sure both sides of the fence are clear of the blade's cutting path. With the power OFF, move the blade through its full range of motion to check this.

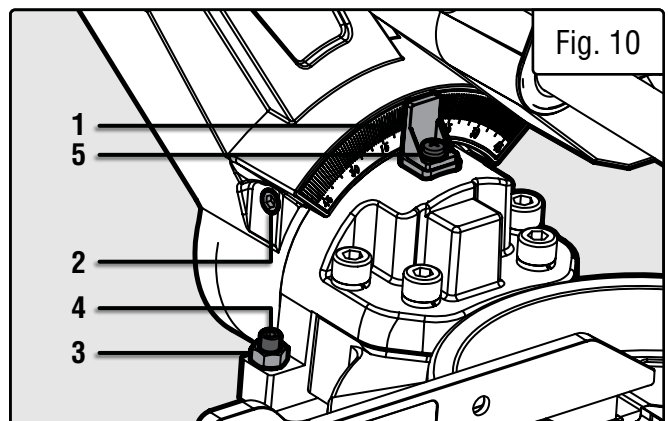

ASSEMBLY & ADJUSTMENTS

SETTING THE BEVEL SCALE INDICATOR

1. Before setting the bevel scale indicator, the table must be perpendicular to the saw blade. See section titled, "Squaring the Table with the Blade" on page 15.
2. Loosen the screw (Fig. 10 - 5) holding the bevel scale indicator.
3. Adjust the direction of the indicator so that it accurately points to 0° on the bevel scale. Tighten the screw.

ADJUSTING THE CUTTING DEPTH

The saw cutting depth can be adjusted if you would like to perform a kerfing or rabbet cut that does not cut all the way through the workpiece.

1. Unplug the tool from its power source and raise the saw head assembly.
2. Locate the depth stop settings on the right side of the saw (Fig. 11).
3. Pull down on the saw head to check the current setting. To change the setting, continue to step 4.
4. Loosen the depth stop knob (Fig. 11 - 1). **To increase depth**, turn the depth stop knob counterclockwise. **To decrease depth**, turn the depth stop knob clockwise.
5. Check that the blade will not hit the table, fence, kerf board, or other part of the saw during the cut. Check the cutting depth setting by completing a test cut on a piece of scrap wood. Repeat steps 4 - 5 until the desired depth is achieved.

ADJUSTING THE FENCE

1. Loosen the fence adjustment knob (Fig. 12 - 1).
2. Adjust the fence as desired. The top portion of the left fence (Fig. 12 - 2) can slide to the left and right, while the bottom portion of the fence (Fig. 12 - 3) stays stationary.
3. Tighten the fence adjustment knob to lock the fence into place.

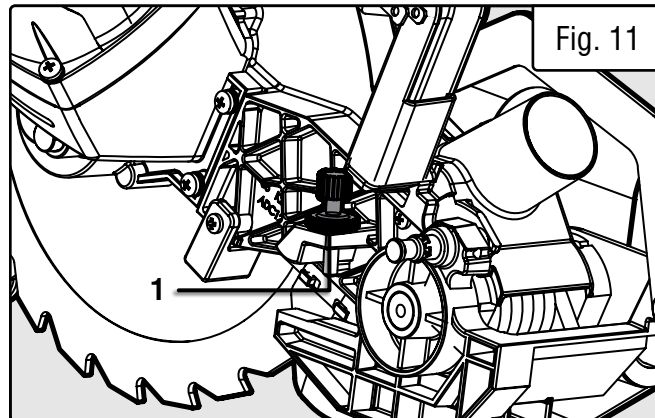

⚠ WARNING: DO NOT adjust the depth stop screw. Only adjust the depth stop knob (Fig. 11 - 1). The depth stop screw is used to prevent the blade from cutting the table during normal cutting. DO NOT adjust the depth stop screw.

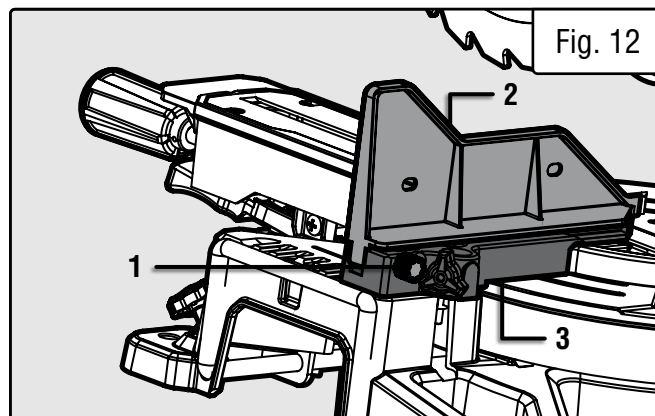

⚠ WARNING: To prevent serious injury, after making any adjustments to the cutting angle, make sure both sides of the fence are clear of the blade's cutting path. With the power OFF, move the blade through its full range of motion to check this.

ASSEMBLY & ADJUSTMENTS

CHANGING THE SAW BLADE

DANGER! Never try to use a blade larger than the stated capacity of the saw. Do not use a blade thicker than 1.9mm. It will prevent the blade screw from properly securing the blade on the spindle. Install the suitable blade for your cutting operation.

1. Unplug the tool from its power source.
2. Lift the saw arm to the upper position and lock it in place. Raise the lower blade guard (Fig. 13 - 1) out of the way and hold it up.
3. Firmly press down the saw spindle lock (Fig. 13 - 2) below the operating handle and hold it in. Use the included 6mm hex wrench to turn the arbor bolt clockwise and remove it (the bolt is left-hand threaded) (Fig. 13 - 3). Remove the washer, outer flange, and arbor insert. Make sure the inner flange stays in place on the arbor.
4. Slowly remove the blade by pulling it out and down. Clean the arbor bolt, washer, outer flange, and arbor insert.
5. Place the arbor insert onto the spindle. Place the new blade over the arbor insert.

IMPORTANT: Make sure the blade's rotation arrow points in the same direction as the rotation arrow on the upper blade guard.

6. Reinstall the outer flange, washer, and arbor bolt. Hold down the spindle lock and tighten the arbor bolt with the hex wrench, turning it counterclockwise. Release the spindle lock.
7. Allow the lower blade guard to return back into position.

IMPORTANT: Carefully rotate the saw blade and make sure that it does not wobble. Lower the saw arm and check that the blade does not contact the kerf board, with the saw at 0° and 45° bevel angles. Make sure the lower blade guard operates properly before using the saw.

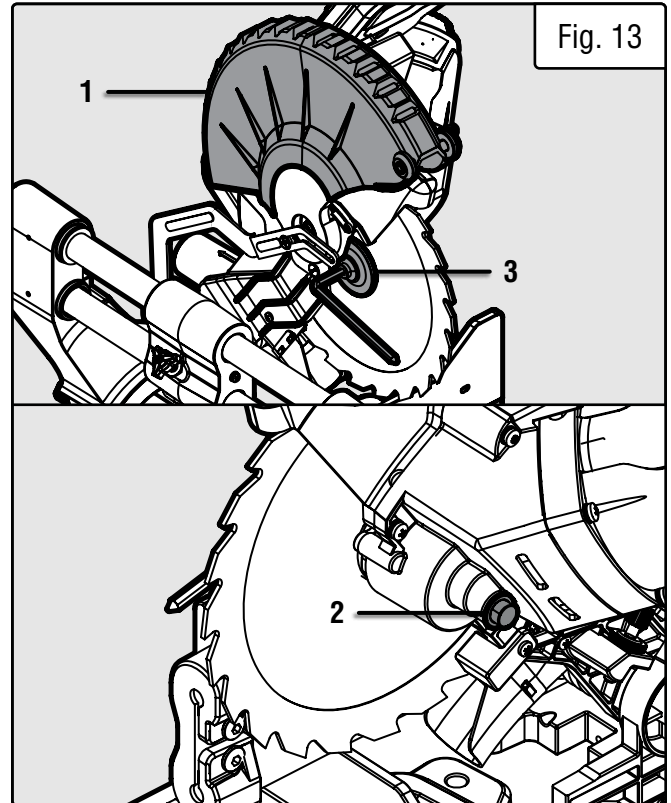

OPERATION

⚠ WARNING! Do not plug in or turn on the tool until it is fully assembled according to the instructions. Read through and become familiarized with the following procedures of handling and adjusting your tool. Failure to follow the safety instructions may result in serious personal injury.

⚠ WARNING! Before operating the miter saw, make sure to equip yourself with a dust mask, ear protection, and safety glasses for protection from possible injuries. Tie back long hair and do not wear loose clothing or jewelry. **DO NOT** look into the laser beam, this can cause serious eye damage or blindness. Do not wear gloves while operating the saw.

1. RAISE THE SAW ARM

Before operation, raise the saw arm from the lower position. See section titled, "Raising/Lowering the Saw Arm" on page 12.

2. SET UP THE CUT ANGLE & DEPTH

The miter saw can be set up to create cuts at different angles by adjusting the angle of the miter table and the saw bevel angle. There are four types of cuts you can create: a cross cut, a miter cut, a bevel cut, and a compound cut. See Fig. 14 to understand each type of cut. If you do not want to cut all the way through your workpiece, adjust the cutting depth. See note below.

To adjust the bevel angle: see section titled, "Adjusting the Bevel Angle" on page 12. **To adjust the miter angle:** see section titled, "Adjusting the Miter Angle" on page 13. **To adjust the cutting depth:** see section titled, "Adjusting the Cutting Depth" on page 16.

2. SET UP SLIDING FUNCTION

For materials with a width under 2-1/2 inches (63 mm): the sliding function isn't necessary. See section titled, "Setting Up Arm Slide" on page 12 to disable the sliding function.

For materials with a width over 2-1/2 inches (63 mm): the saw arm will need to slide to cut through the workpiece. See section titled, "Setting Up Arm Slide" on page 12 to enable the sliding function.

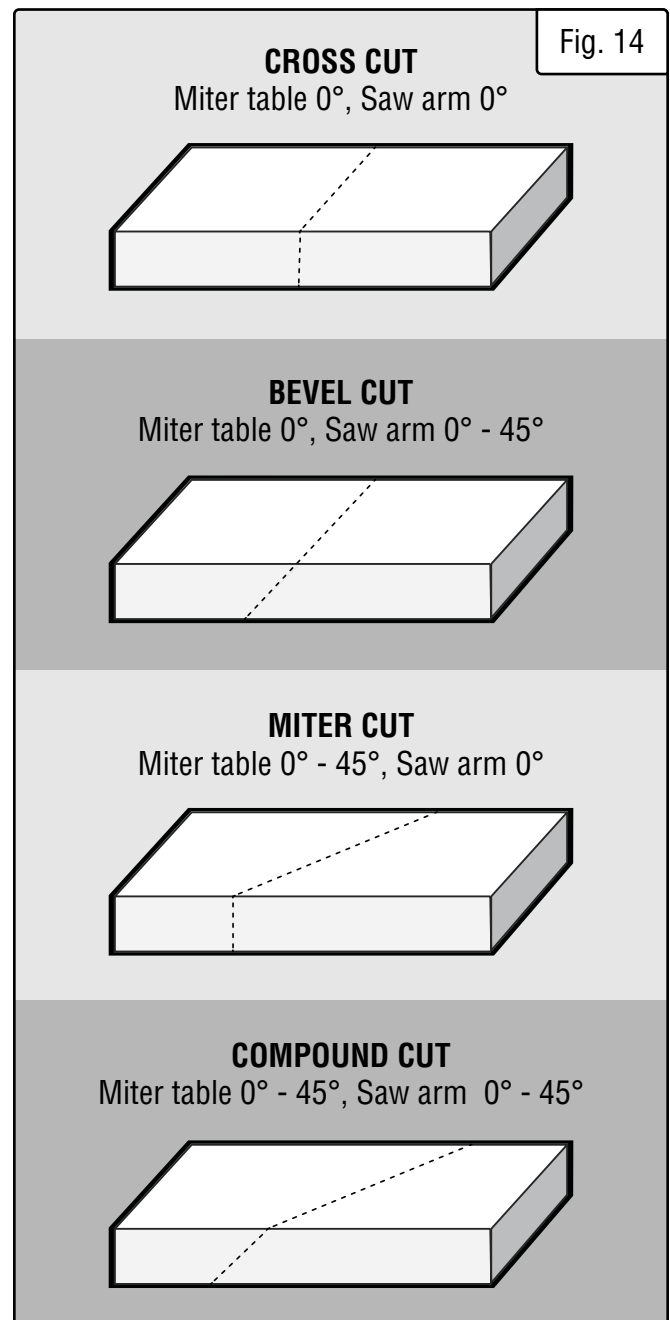

OPERATION

⚠ WARNING! Do not plug in or turn on the tool until it is fully assembled according to the instructions. Read through and become familiarized with the following procedures of handling and adjusting your tool. Failure to follow the safety instructions may result in serious personal injury.

⚠ WARNING! Before operating the miter saw, make sure to equip yourself with a dust mask, ear protection, and safety glasses for protection from possible injuries. Tie back long hair and do not wear loose clothing or jewelry.

4. SET UP WORKPIECE

Place the workpiece flat on the table with one edge securely against the fence (Fig. 15).

Warped Boards: If the board is warped, place the concave side against the table (Fig. 16). **CAUTION:** The board could break and jam the blade if the convex side is placed against the table.

Long Boards: When cutting long workpieces, support the opposite end of the material with the support bars, a roller stand, or a work surface that is level with the saw table.

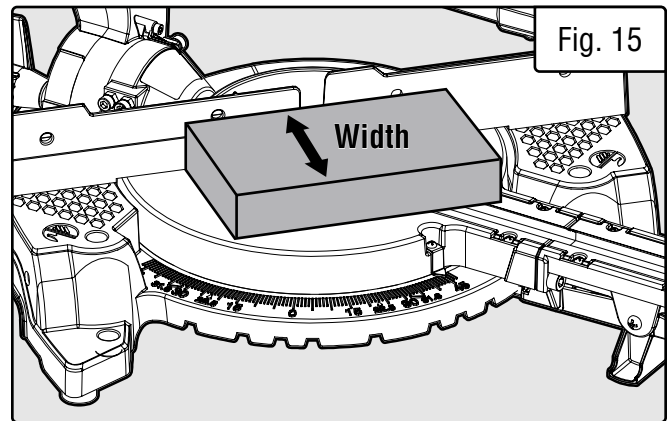

5. SECURE WORKPIECE

Secure the workpiece with the hold-down clamp on the fixed table whenever possible to prevent the material from moving during the cutting operations. See section, "Installing the Clamp Assembly" on page 13.

6. CHECK BEFORE OPERATION

- Check that the miter table does not rotate and the saw arm does not bevel.
- Check that the workpiece is fully supported, against the fence and securely clamped down.
- Check that you have the proper blade for the material you are cutting.
- Without turning on the saw, perform a dry run of the cutting operation to check that nothing is obstructing the path of the saw.

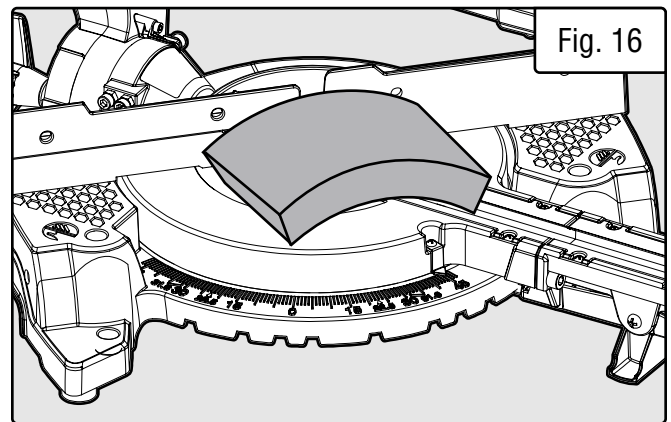

⚠ WARNING: Be sure to tighten the miter lock and bevel lock before making a cut. Failure to do so could result in the table moving during the cut and may cause serious personal injuries.

Instructions continue on the next page

OPERATION

7. PERFORM THE CUT

1. Plug in the miter saw. Turn on the LED switch (Fig. 17 - 1) to see where your cut will land on the material. **CAUTION:** DO NOT look into the LED light or point it at any living thing.

2. Grip the operating handle firmly, press in the power switch lock (Fig. 17 - 2) squeeze the power trigger (Fig. 17 - 3) to turn the saw ON.

3. Allow the blade to reach full speed. Make sure the workpiece is held securely against the table and fence at all times. If the material binds the blade, release the power trigger.

- **For non-sliding cuts:** Slowly lower the blade into and through the workpiece.
- **For sliding cuts:** Pull the saw arm all towards the front of the machine. Slowly lower the blade into the workpiece while steadily pushing it away from you until the workpiece is cut (Fig. 18). **CAUTION:** Never slide the saw arm towards yourself while cutting. Always push away.

4. Release the power trigger and wait until the blade fully stops before raising it from the workpiece.

5. Unplug the miter saw before leaving your work station. Clean your work station and store tools out of reach of children.

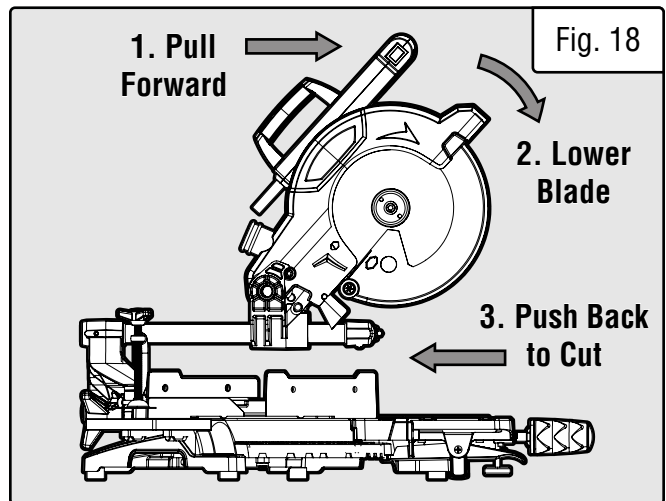
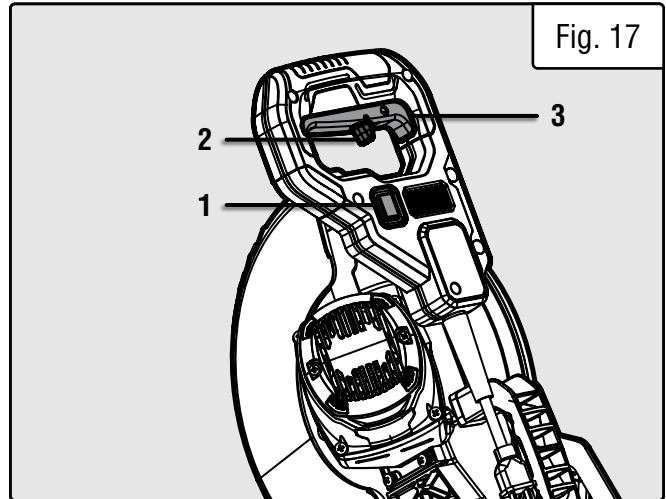

MAINTENANCE

⚠ WARNING! To avoid accidents, turn OFF and unplug the tool from the electrical outlet before cleaning, adjusting, or performing any maintenance work.

⚠ WARNING! Any attempt to repair or replace electrical parts on this tool may be hazardous. Servicing of the tool must be performed by a qualified technician. When servicing, use only identical WEN replacement parts. Use of other parts may be hazardous or induce product failure.

NOTE: Electric tools used on fiberglass material, wallboard, spackling compounds, or plaster are subject to accelerated wear and possible premature failure because the fiberglass chips and grindings are highly abrasive to bearings, brushes, commutators, etc. Consequently, we do not recommend using this tool for extended work on these types of materials. However, if you do work with any of these materials, it is extremely important to clean the tool using compressed air after operation.

MAINTENANCE

ROUTINE INSPECTION

Before each use, inspect the general condition of the tool. If any of these following conditions exist, do not use until parts are replaced or the saw is properly repaired.

Check for:

- Loose hardware,
- Misalignment or binding of moving parts,
- Damaged cord/electrical wiring,
- Cracked or broken parts, and
- Any other condition that may affect its safe operation.

CLEANING & STORAGE

CAUTION! Most plastics are susceptible to damage from various types of commercial solvents. Do not use any solvents or cleaning products that could damage the plastic parts. Some of these include but are not limited to: gasoline, carbon tetrachloride, chlorinated cleaning solvents, and household detergents that contain ammonia.

1. Keep the ventilation openings free from dust and debris to prevent the motor from overheating.
2. Wipe the tool surfaces clean with a clean cloth. Make sure water does not get into the tool.
3. Store the tool in a clean and dry place away from the reach of children. Store in temperatures between 41° to 86°F.
4. Cover the miter saw in order to protect it from dust and moisture. It is preferable to store it in its original packaging with the instruction manual and all accessories.

PRODUCT DISPOSAL

Used power tools should not be disposed of together with household waste. This product contains electronic components that should be recycled. Please take this product to your local recycling facility for responsible disposal and to minimize its environmental impact.



Please recycle the packaging and electronic components where facilities exist.

LUBRICATION

The bearings of your miter saw are permanently sealed and require no extra lubrication. The gearbox is also sufficiently lubricated from the factory and requires no additional lubrication.

CARBON BRUSH REPLACEMENT

Replacement carbon brushes (Part No. MM1015-123) can be ordered at wenproducts.com. Only genuine WEN replacement brushes designed specifically for your tool should be used. Carbon brushes are **not** covered under the two-year warranty.

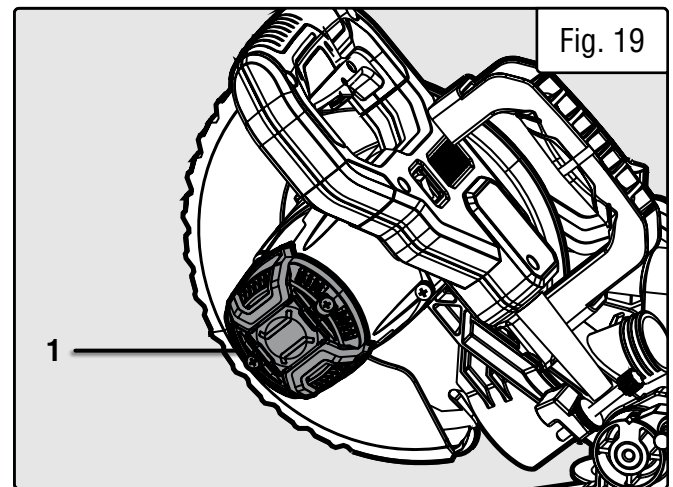

1. To access the carbon brushes, remove the motor end cap (Fig. 19 - 1) by unscrewing the two screws holding it in place.
2. Carefully remove the old carbon brushes using pliers.
3. Install the new carbon brushes. Both carbon brushes should be replaced at the same time. Replace the motor end cap.

NOTE: New carbon brushes tend to spark for a few minutes during the first use as they wear down.

TROUBLESHOOTING GUIDE

⚠ WARNING! Stop using the tool immediately if any of the following problems occur. Repairs and replacements should only be performed by an authorized technician. For any questions, please contact our customer service at **1-(800) 232-1195**, M-F 8-5 CST or email us at **techsupport@wenproducts.com**.

PROBLEM	CAUSE	SOLUTION
Ineffective cutting performance.	1. Blade is dull.	1. Sharpen or replace blade.
	2. Blade is dirty.	2. Remove the blade and clean the surface and cutting edge with steel wool and turpentine.
	3. The blade is not secure.	3. Make sure the blade flanges are flush against the blade and arbor bolt is tightened completely.
	4. Incorrect blade used for workpiece.	5. Ensure the blade is compatible with the material type and thickness being cut.
	6. Blade is installed improperly.	6. Ensure blade is installed in correct orientation.
Excessive noise or vibration.	1. Not mounted properly.	1. Make sure the saw is mounted securely to a flat and level work surface.
	2. Blade is damaged.	2. Replace blade.
	3. Blade is not secure.	3. Make sure the blade flanges are flush against the blade and arbor bolt is tightened completely.
Blade will not turn.	1. Excessive sawdust or chips between blade and frame.	1. Clean the space between the blade and frame with compressed air and ensure no chips are stuck within.
	2. Spindle lock is engaged.	2. Disengage the spindle lock; move blade back and forth to ensure it is disengaged.

TROUBLESHOOTING GUIDE

⚠ WARNING! Stop using the tool immediately if any of the following problems occur. Repairs and replacements should only be performed by an authorized technician. For any questions, please contact our customer service at **1-(800) 232-1195**, M-F 8-5 CST or email us at **techsupport@wenproducts.com**.

PROBLEM	CAUSE	SOLUTION
Motor does not start.	1. Power cord damaged or not properly plugged in.	1. Check the power cord, extension cord, power plug, and the power outlet. Do not use the tool if any cord is damaged.
	2. Defective power switch.	2. Stop using the tool and call 1-800-232-1195 for customer service.
	3. Insufficient power from power outlet.	3. Make sure the outlet is functional and is the right capacity for the tool.
	4. Worn carbon brushes.	4. Inspect and replace carbon brushes as needed (see page 21). Replacement carbon brushes (Part No. MM1015-123) can be ordered from wenproducts.com .
	5. Defective motor or other internal problem.	5. Stop using the tool and call 1-800-232-1195 for customer service.
Saw overheats.	1. Tool forced to work too fast.	1. Do not force the tool. Let it work at its own pace. Ensure blade selection is appropriate for cut type and workpiece.
	2. Wrong extension cord gauge.	2. Select proper extension cord. Refer to "Electrical Information" on p. 8.
	3. Blocked motor housing vents.	3. Wear safety glasses & dust mask. Blow dust out of motor housing vents.

EXPLODED VIEW & PARTS LIST

MITER SAW

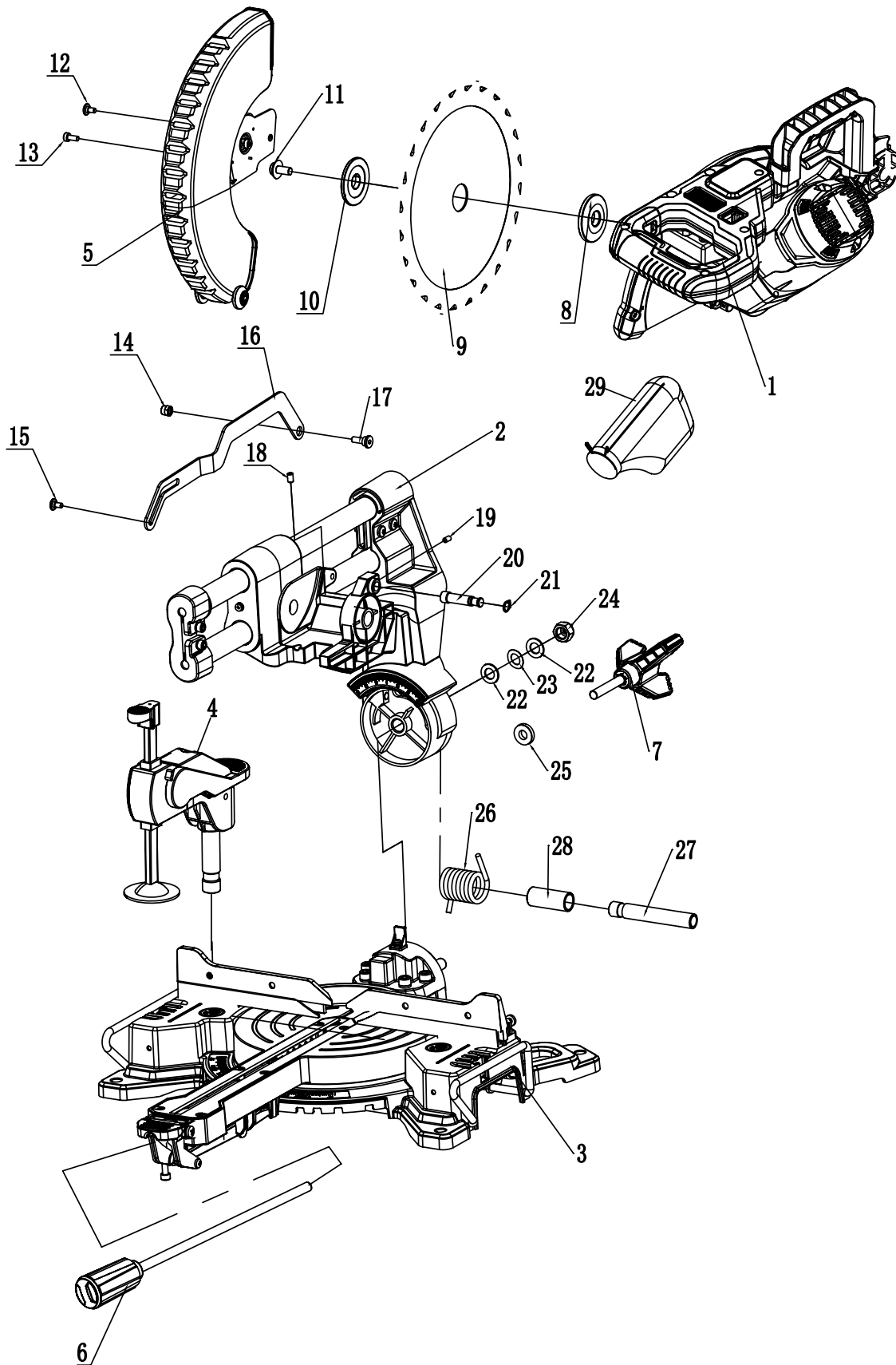

EXPLODED VIEW & PARTS LIST

MITER SAW

No.	Part No.	Description	Qty.
0-01	MM1015-001	Motor Assembly	1
0-02	MM1015-002	Bevel Arm Assembly	1
0-03	MM1015-003	Base Assembly	1
0-04	MM1015-004	Quick-clamp Assembly	1
0-05	MM1015-005	Blade Guard Assembly	1
0-06	MM1015-006	Miter Lock Handle Assembly	1
0-07	MM1015-007	Bevel Lock Handle	1
0-08	MM1015-008	Inner Blade Disc	1
0-09	MM1015-009	Saw Blade	1
0-10	MM1015-010	Outer Blade Disc	1
0-11	MM1015-011	Socket Screw M8x16	1
0-12	MM1015-012	Shoulder Screw M5x10	1
0-13	MM1015-013	Socket Screw M5x12	1

No.	Part No.	Description	Qty.
0-14	MM1015-014	Lock Nut M6	1
0-15	MM1015-015	Recessed Shaft Screw M5x10	1
0-16	MM1015-016	Blade Guard Linkage	1
0-17	MM1015-017	Screw M6x16	1
0-18	MM1015-018	Set Screw M6x10	1
0-19	MM1015-019	Bead Screw M5x10	1
0-20	MM1015-020	Locking Pin	1
0-21	MM1015-021	C-ring	1
0-22	MM1015-022	Washer	2
0-23	MM1015-023	Wave Washer	1
0-24	MM1015-024	Lock Nut M12	1
0-25	MM1015-025	Washer	1
0-26	MM1015-026	Spring	1
0-27	MM1015-027	Pivot shaft	1
0-28	MM1015-028	Spring sleeve	1
0-29	MM1015-029	Dust bag	1

NOTE: Not all parts may be available for purchase. Parts and accessories that wear down over the course of normal use are not covered under the warranty.

EXPLODED VIEW & PARTS LIST

MOTOR ASSEMBLY

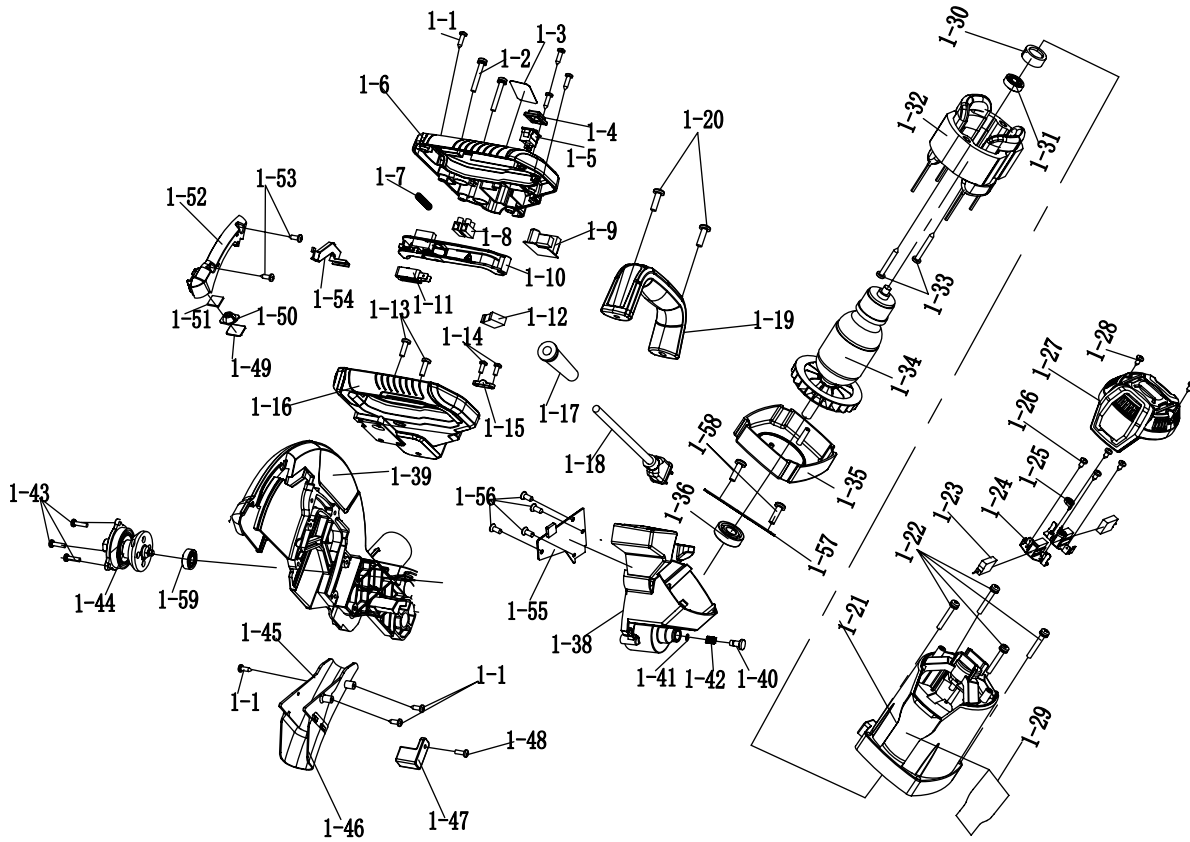

NOTE: Not all parts may be available for purchase. Parts and accessories that wear down over the course of normal use are not covered under the warranty.

EXPLODED VIEW & PARTS LIST

MOTOR ASSEMBLY

No.	Part No.	Description	Qty.
1-01	MM1015-101	Self-tapping Screw	7
1-02	MM1015-102	Cross-head Screw M5X35	2
1-03	MM1015-103	Warning Label	1
1-04	MM1015-104	LED Switch Cover	1
1-05	MM1015-105	LED Switch	1
1-06	MM1015-106	Upper Handle	1
1-07	MM1015-107	Handle Spring	1
1-08	MM1015-108	Terminal	1
1-09	MM1015-109	Transformer	1
1-10	MM1015-110	Switch Trigger Assembly	1
1-11	MM1015-111	Switch	1
1-12	MM1015-112	Capacitor	1
1-13	MM1015-113	Cross-head Screw M5x20	2
1-14	MM1015-114	Self-tapping Screw	2
1-15	MM1015-115	Cord Bracket	1
1-16	MM1015-116	Lower Handle	1
1-17	MM1015-117	Cable Sheath	1
1-18	MM1015-118	Power Cord	1
1-19	MM1015-119	Carrying Handle	1
1-20	MM1015-120	Cross-head Screw M6x25	2
1-21	MM1015-121	Motor Housing	1
1-22	MM1015-122	Cross-head Screw M5x40	4
1-23	MM1015-123	Carbon Brush	2
1-24	MM1015-124	Carbon Brush Holder	2
1-25	MM1015-125	Carbon Brush Spring	2
1-26	MM1015-126	Self-tapping Screw	3
1-27	MM1015-127	Motor End Cap	1
1-28	MM1015-128	Self-tapping Screw	2
1-29	MM1015-129	Specifications Label	1
1-30	MM1015-130	Bearing Sleeve	1

No.	Part No.	Description	Qty.
1-31	MM1015-131	Bearing	1
1-32	MM1015-132	Stator	1
1-33	MM1015-133	Self-tapping Screw	2
1-34	MM1015-134	Armature	1
1-35	MM1015-135	Baffle	1
1-36	MM1015-136	Bearing	2
1-37	MM1015-137	Cross Head Screw M5x16	5
1-38	MM1015-138	Gear Casing	1
1-39	MM1015-139	Upper Blade Guard	1
1-40	MM1015-140	Locking Pin	1
1-41	MM1015-141	E-ring	1
1-42	MM1015-142	Spring	1
1-43	MM1015-143	Cross-head Screw M4x16	3
1-44	MM1015-144	Arbor Assembly	1
1-45	MM1015-145	Dust Chute	1
1-46	MM1015-146	Dust Guide	1
1-47	MM1015-147	Collision Block	1
1-48	MM1015-148	Cross-head Screw M4x12	1
1-49	MM1015-149	LED Cover	1
1-50	MM1015-150	LED Shade	1
1-51	MM1015-151	LED	1
1-52	MM1015-152	LED Housing	1
1-53	MM1015-153	Cross-head Screw M4x10	2
1-54	MM1015-154	LED Wire Housing	1
1-55	MM1015-155	Gearbox Wire Cover	1
1-56	MM1015-156	Recessed Head Screw	4
1-57	MM1015-157	Bearing Cover	1
1-58	MM1015-158	Cross-head Screw M5x12	2
1-59	MM1015-159	Bearing	1

EXPLODED VIEW & PARTS LIST

PIVOT ASSEMBLY

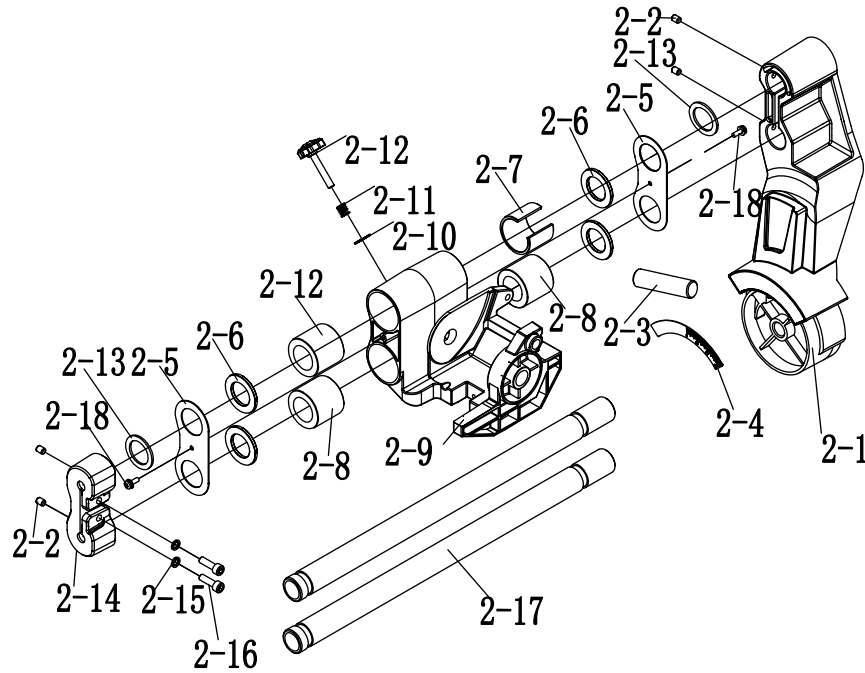

No.	Part No.	Description	Qty.
2-01	MM1015-201	Bevel Arm	1
2-02	MM1015-202	Set Screw M6x10	4
2-03	MM1015-203	Set Screw M8x30	1
2-04	MM1015-204	Bevel Scale	1
2-05	MM1015-205	Liner Bearing Cover	2
2-06	MM1015-206	Washer	2
2-07	MM1015-207	Rubber Washer	1
2-08	MM1015-208	Linear Bearing	3
2-09	MM1015-209	Slide Bracket	1

No.	Part No.	Description	Qty.
2-10	MM1015-210	Washer	1
2-11	MM1015-211	Spring	1
2-12	MM1015-212	Knob M6X30	1
2-13	MM1015-213	Spring Washer	2
2-14	MM1015-214	Slide End Cap	1
2-15	MM1015-215	Spring washer	1
2-16	MM1015-216	Socket Screw M6x35	2
2-17	MM1015-217	Slide Rail	2
2-18	MM1015-218	Cross-head Screw M4x12	2

NOTE: Not all parts may be available for purchase. Parts and accessories that wear down over the course of normal use are not covered under the warranty.

EXPLODED VIEW & PARTS LIST

BASE AND TABLE ASSEMBLY

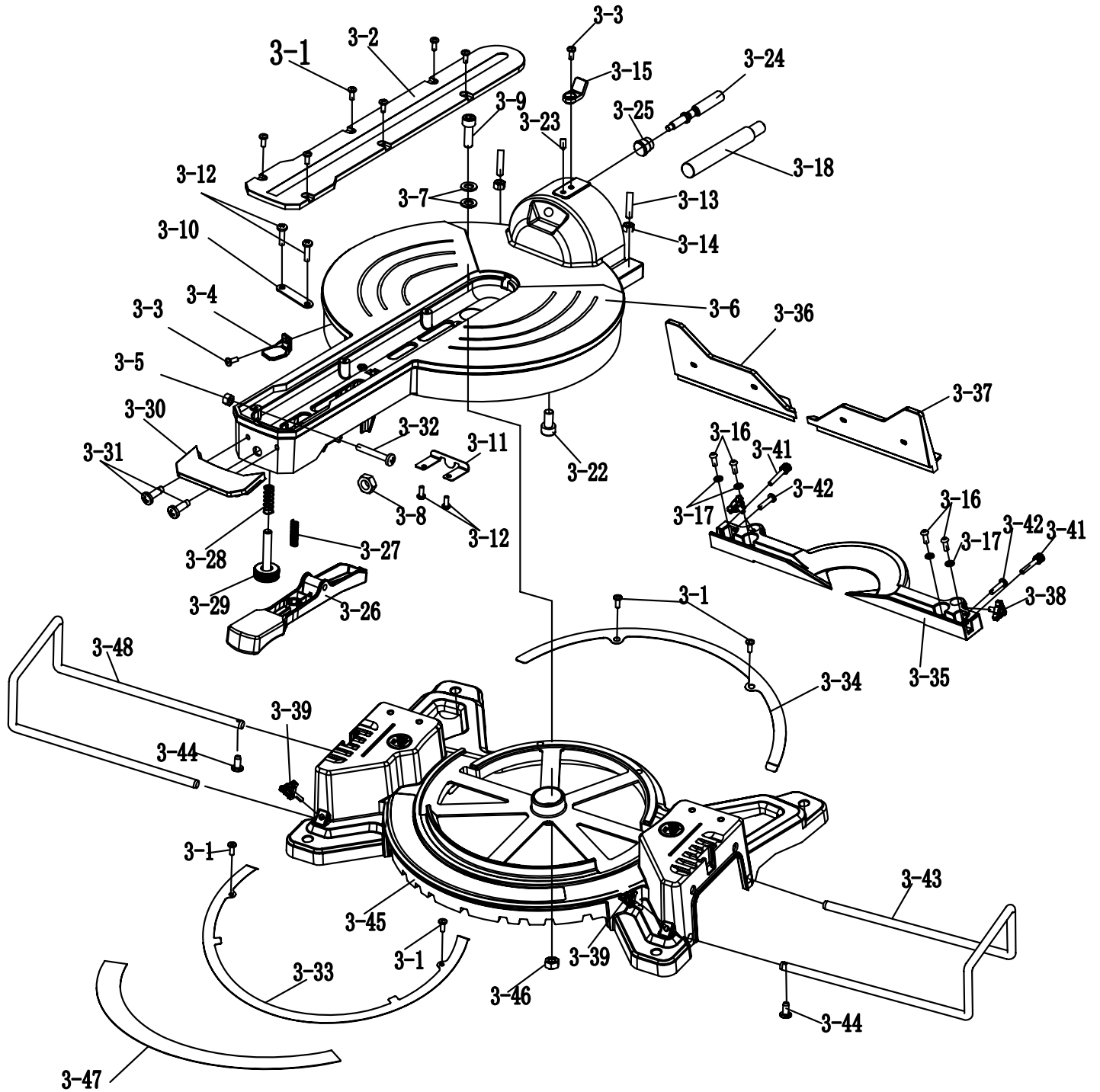

EXPLODED VIEW & PARTS LIST

BASE AND TABLE ASSEMBLY

No.	Part No.	Description	Qty.
3-1	MM1015-301	Cross-head Screw M4x10	10
3-2	MM1015-302	Table Insert	1
3-3	MM1015-303	Cross-head Screw M4x12	2
3-4	MM1015-304	Miter Angle Pointer	1
3-5	MM1015-305	Lock Nut M6	1
3-6	MM1015-306	Miter Table	1
3-7	MM1015-307	Washer	2
3-8	MM1015-308	Square Nut M8	1
3-9	MM1015-309	Socket Screw M8x25	1
3-10	MM1015-310	Nut Clamp	1
3-11	MM1015-311	Lock Plate	1
3-12	MM1015-312	Cross-head Screw M4x6	4
3-13	MM1015-313	Set Screw M6x25	2
3-14	MM1015-314	Lock Nut M6	2
3-15	MM1015-315	Bevel Angle Pointer	1
3-16	MM1015-316	Socket Screw M8x35	4
3-17	MM1015-317	Spring Washer	4
3-18	MM1015-318	Bevel Shaft	1
3-22	MM1015-322	Socket Screw M10x25	1
3-23	MM1015-323	Bead Set Screw M5x10	1
3-24	MM1015-324	Miter Angle Pin	1
3-25	MM1015-325	Miter Angle Pin Knob	

No.	Part No.	Description	Qty.
3-26	MM1015-326	Miter Lock Lever	1
3-27	MM1015-327	Spring	1
3-28	MM1015-328	Support Foot Spring	1
3-29	MM1015-329	Table Support Foot	1
3-30	MM1015-330	Table Angle guard	1
3-31	MM1015-331	Cross head screws	2
3-32	MM1015-332	Cross-head Screw M6x40	1
3-33	MM1015-333	Large Miter Table Slide Plate	1
3-34	MM1015-334	Small Miter Table Slide Plate	1
3-35	MM1015-335	Fence Base	1
3-36	MM1015-336	Left Sliding Fence	1
3-37	MM1015-337	Right Sliding Fence	1
3-38	MM1015-338	Knob	2
3-39	MM1015-339	Knob M6x35	2
3-41	MM1015-341	Knob	2
3-42	MM1015-342	Cross head screws	2
3-43	MM1015-343	Right Extension Bar	1
3-44	MM1015-344	Cross-head Screw M4x8	2
3-45	MM1015-345	Base	1
3-46	MM1015-346	Lock Nut M8	1
3-47	MM1015-347	Miter scale	1
3-48	MM1015-348	Left Extension Bar	1

NOTE: Not all parts may be available for purchase. Parts and accessories that wear down over the course of normal use are not covered under the warranty.

EXPLODED VIEW & PARTS LIST

QUICK-CLAMP ASSEMBLY

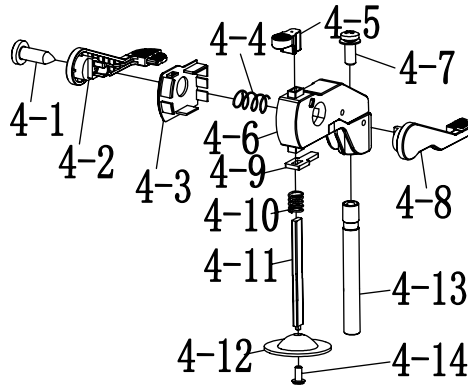

No.	Part No.	Description	Qty.
4-01	MM1015-401	Self-tapping Screw	1
4-02	MM1015-402	Right Lock Handle	1
4-03	MM1015-403	End cap	1
4-04	MM1015-404	Spring	1
4-05	MM1015-405	Clamp Rod End Cap	1
4-06	MM1015-406	Clamp Body	1
4-07	MM1015-407	Cross-head Screw M5x16	1

No.	Part No.	Description	Qty.
4-08	MM1015-408	Left Lock Handle	1
4-09	MM1015-409	Clamp Locking Tab	1
4-10	MM1015-410	Spring	1
4-11	MM1015-411	Clamp Rod	1
4-12	MM1015-412	Clamp plate	1
4-13	MM1015-413	Clamp Support Shaft	1
4-14	MM1015-414	Cross-head Screw M4x12	1

BLADE GUARD ASSEMBLY

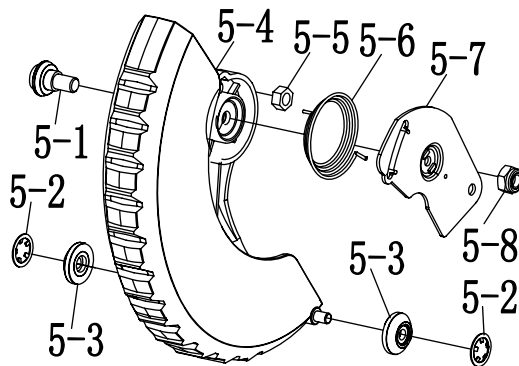

No.	Part No.	Description	Qty.
5-01	MM1015-501	Shoulder Screw M6x12.5	1
5-02	MM1015-502	Washer	2
5-03	MM1015-503	Wheel	2
5-04	MM1015-504	Lower Blade Guard	1

No.	Part No.	Description	Qty.
5-05	MM1015-505	Hex Nut M5	1
5-06	MM1015-506	Torsion Spring	1
5-07	MM1015-507	Blade Guard Support	1
5-08	MM1015-508	Lock Nut M6	1

EXPLODED VIEW & PARTS LIST

MITER LOCK HANDLE ASSEMBLY

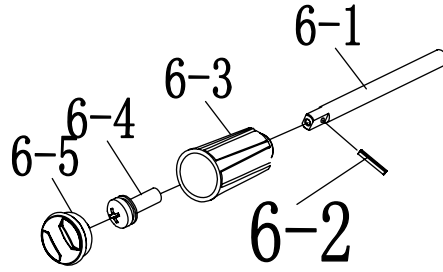

No.	Part No.	Description	Qty.
6-01	MM1015-601	Miter Lock Rod	1
6-02	MM1015-602	Spring Pin	1
6-03	MM1015-603	Miter Lock Knob	1

No.	Part No.	Description	Qty.
6-04	MM1015-604	Cross-head Screw M4x12	1
6-05	MM1015-605	End Cap	1

BEVEL LOCK HANDLE ASSEMBLY

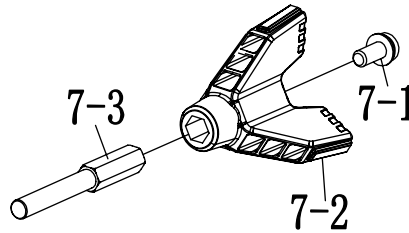

No.	Part No.	Description	Qty.
7-01	MM1015-701	Cross-head Screw M4x12	1
7-02	MM1015-702	Bevel Lock Knob	1
7-03	MM1015-703	Hex Bolt	1

ARBOR ASSEMBLY

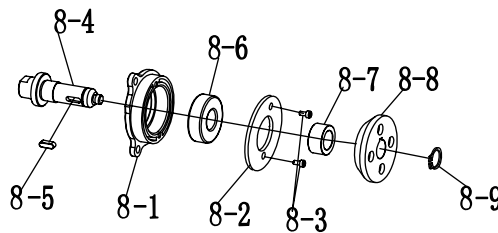

No.	Part No.	Description	Qty.
8-01	MM1015-801	Gear Box Cover	1
8-02	MM1015-802	Front Cover Gasket	1
8-03	MM1015-803	Socket Screw M4x10	2
8-04	MM1015-804	Arbor	1
8-05	MM1015-805	Flat Key	1

No.	Part No.	Description	Qty.
8-06	MM1015-806	Bearing	1
8-07	MM1015-807	Spacer Sleeve	1
8-08	MM1015-808	Gear	1
8-09	MM1015-809	C-ring	1

WARRANTY STATEMENT

WEN Products is committed to building tools that are dependable for years. Our warranties are consistent with this commitment and our dedication to quality.

LIMITED WARRANTY OF WEN PRODUCTS FOR HOME USE

GREAT LAKES TECHNOLOGIES, LLC (“Seller”) warrants to the original purchaser only, that all WEN consumer power tools will be free from defects in material or workmanship during personal use for a period of two (2) years from date of purchase or 500 hours of use; whichever comes first. Ninety days for all WEN products if the tool is used for professional or commercial use. Purchaser has 30 days from the date of purchase to report missing or damaged parts.

SELLER’S SOLE OBLIGATION AND YOUR EXCLUSIVE REMEDY under this Limited Warranty and, to the extent permitted by law, any warranty or condition implied by law, shall be the replacement of parts, without charge, which are defective in material or workmanship and which have not been subjected to misuse, alteration, careless handling, misrepair, abuse, neglect, normal wear and tear, improper maintenance, or other conditions adversely affecting the Product or the component of the Product, whether by accident or intentionally, by persons other than Seller. To make a claim under this Limited Warranty, you must make sure to keep a copy of your proof of purchase that clearly defines the Date of Purchase (month and year) and the Place of Purchase. Place of Purchase must be a direct vendor of Great Lakes Technologies, LLC. Purchasing through third party vendors, including but not limited to garage sales, pawn shops, resale shops, or any other secondhand merchant, voids the warranty included with this product. Contact tech-support@wenproducts.com or 1-800-232-1195 with the following information to make arrangements: your shipping address, phone number, serial number, required part numbers, and proof of purchase. Damaged or defective parts and products may need to be sent to WEN before the replacements can be shipped out.

Upon the confirmation of a WEN representative, your product may qualify for repairs and service work. When returning a product for warranty service, the shipping charges must be prepaid by the purchaser. The product must be shipped in its original container (or an equivalent), properly packed to withstand the hazards of shipment. The product must be fully insured with a copy of the proof of purchase enclosed. There must also be a description of the problem in order to help our repairs department diagnose and fix the issue. Repairs will be made and the product will be returned and shipped back to the purchaser at no charge for addresses within the contiguous United States.

THIS LIMITED WARRANTY DOES NOT APPLY TO ITEMS THAT WEAR OUT FROM REGULAR USAGE OVER TIME, INCLUDING BELTS, BRUSHES, BLADES, BATTERIES, ETC. ANY IMPLIED WARRANTIES SHALL BE LIMITED IN DURATION TO TWO (2) YEARS FROM DATE OF PURCHASE. SOME STATES IN THE U.S. AND SOME CANADIAN PROVINCES DO NOT ALLOW LIMITATIONS ON HOW LONG AN IMPLIED WARRANTY LASTS, SO THE ABOVE LIMITATION MAY NOT APPLY TO YOU.

IN NO EVENT SHALL SELLER BE LIABLE FOR ANY INCIDENTAL OR CONSEQUENTIAL DAMAGES (INCLUDING BUT NOT LIMITED TO LIABILITY FOR LOSS OF PROFITS) ARISING FROM THE SALE OR USE OF THIS PRODUCT. SOME STATES IN THE U.S. AND SOME CANADIAN PROVINCES DO NOT ALLOW THE EXCLUSION OR LIMITATION OF INCIDENTAL OR CONSEQUENTIAL DAMAGES, SO THE ABOVE LIMITATION OR EXCLUSION MAY NOT APPLY TO YOU.

THIS LIMITED WARRANTY GIVES YOU SPECIFIC LEGAL RIGHTS, AND YOU MAY ALSO HAVE OTHER RIGHTS WHICH VARY FROM STATE TO STATE IN THE U.S., PROVINCE TO PROVINCE IN CANADA AND FROM COUNTRY TO COUNTRY.

THIS LIMITED WARRANTY APPLIES ONLY TO ITEMS SOLD WITHIN THE UNITED STATES OF AMERICA, CANADA AND THE COMMONWEALTH OF PUERTO RICO. FOR WARRANTY COVERAGE WITHIN OTHER COUNTRIES, CONTACT THE WEN CUSTOMER SUPPORT LINE. FOR WARRANTY PARTS OR PRODUCTS REPAIRED UNDER WARRANTY SHIPPING TO ADDRESSES OUTSIDE OF THE CONTIGUOUS UNITED STATES, ADDITIONAL SHIPPING CHARGES MAY APPLY.

**THANKS FOR
REMEMBERING**

