

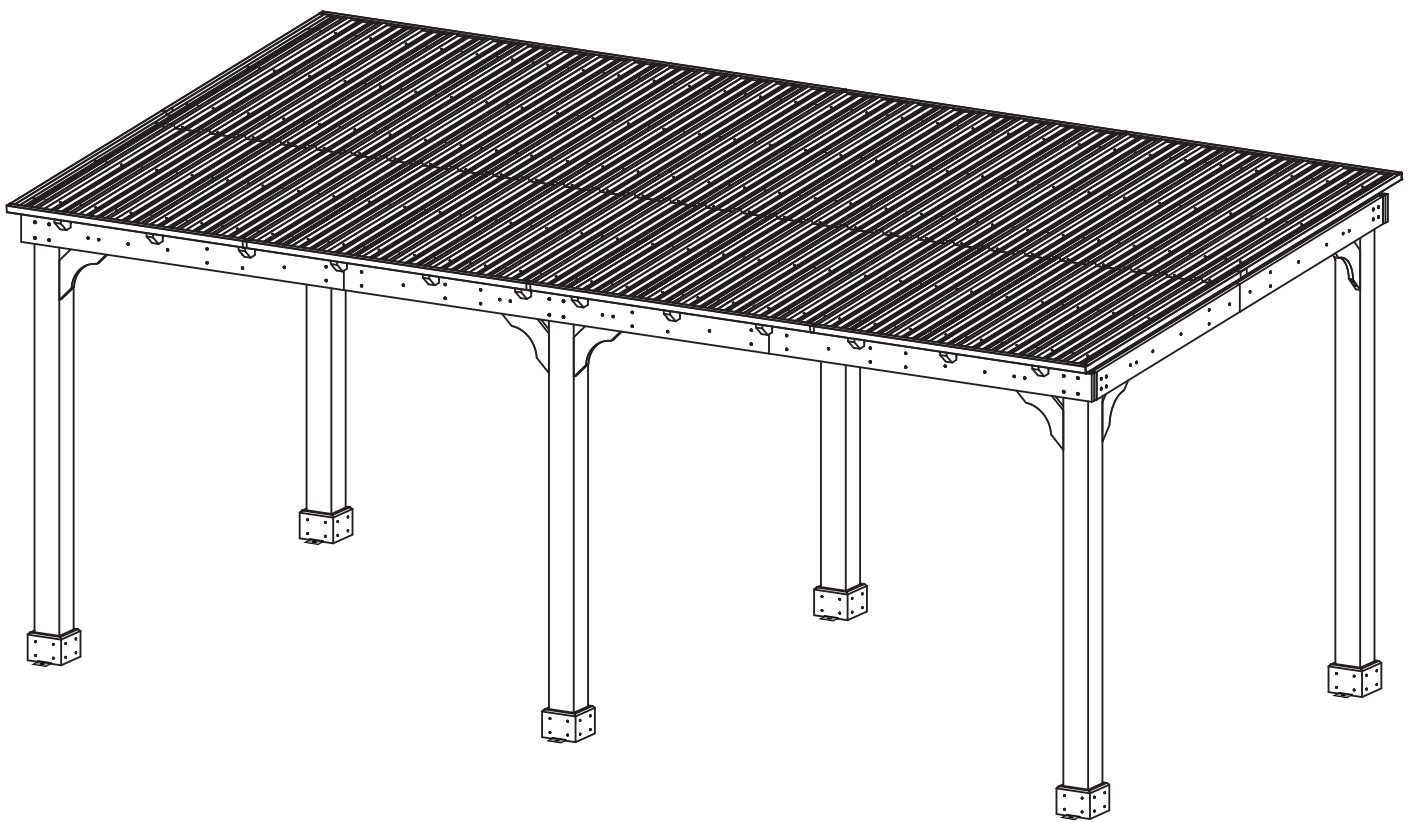

# Wood Pergola



## Instruction Manual



[www.veikous.com](http://www.veikous.com)



[customerservice@veikous.com](mailto:customerservice@veikous.com)

# STOP

**MISSING A PART?  
CALL US BEFORE GOING  
BACK TO THE STORE**

The store where you made your purchase  
Does not stock parts for this item.

If you have assembly questions or you are missing or  
have damaged parts, please call

1-858-324-1911

(Mon - Sun, 10:00 am to 7:00 pm EST)

you can also e-mail [customerservice@veikous.com](mailto:customerservice@veikous.com)

or visit [www.veikous.com](http://www.veikous.com)

Please prefer email contact. Due to busy lines,  
there may be a wait for calls to be answered.

**Please have the following information ready when you contact us,  
so we can assist you promptly.**

- Order number or PO number ( you can find the info on your invoice, receipt or platform account).
- The model number of the product ( printed on the package box ).
- Description of the part from the parts list.

- 
- Read entire assembly manual, paying special attention to the important tips and safety information .
  - Ensure there are no missing pieces by first separating and identifying all parts.
  - Make sure to check packing material for small parts that may have fallen out during shipment.
  - Structures are not intended for public use. The Company does not warranty any of its residential structures subjected to commercial use such as: Daycare, Preschool, Nursery School, Recreational Park, or any similar Commercial Application.
  - This manual contains helpful information concerning assembly preparation, installation procedure and required maintenance.
  - Always keep safety in mind as your structure is being built.
  - Keep these instructions for future reference.



1. Two or more people are required for assembly.



2. You will need one or more stepladders.



3. Wearing protective gloves is recommended.



4. You may need a safety hat.



5. You may need to use a hex key.



6. Please use a Phillips screwdriver.







7. Do not fully tighten screws prior to complete assembly.

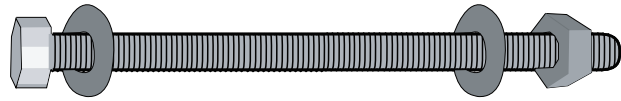
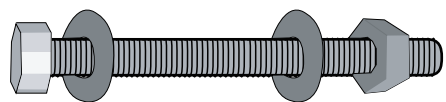
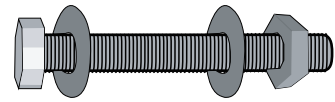
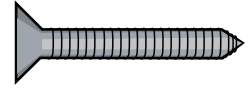
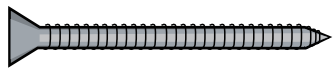
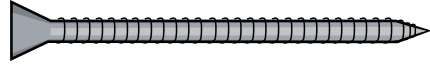

8. For ease of construction, you may need to use a drill.

# Parts Identification

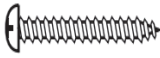
## Hardware

	200mm	Ⓐ X48
	85mm	Ⓑ X28
	60mm	Ⓒ X94
	45mm	Ⓓ X48
	30mm	Ⓔ X36
	50mm	Ⓕ X 242
	70mm	Ⓖ X38
		Ⓗ X12
		Ⓘ X24
	in box 6 16mm	Ⓙ X382
	in box 6	Ⓚ X382

# Wood Components

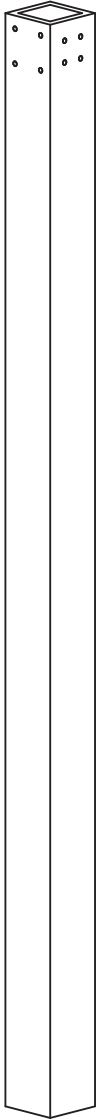

01 X3



02 X3



08 X12



09 X12

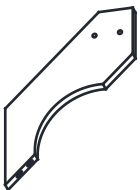

11 X14



12 X12

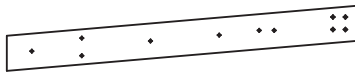

3C X3

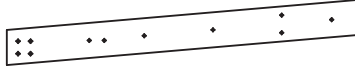

3D X3

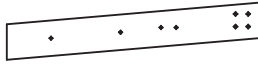

4D X3

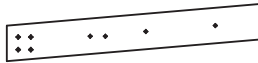

4F X3

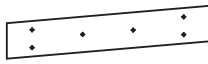

4C X3

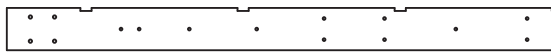

5A X4

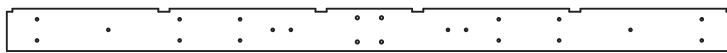

5B X2

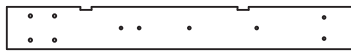

6A X4

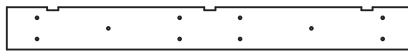

6B X4

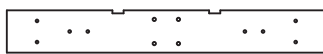

6C X2

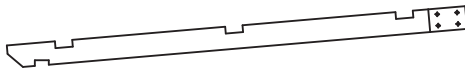

7A X12

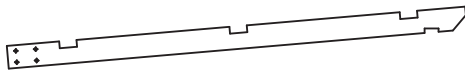

7B X12

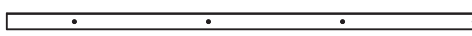

10 X12

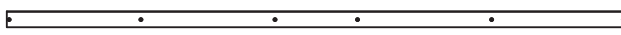

10B X6

# Steel Components

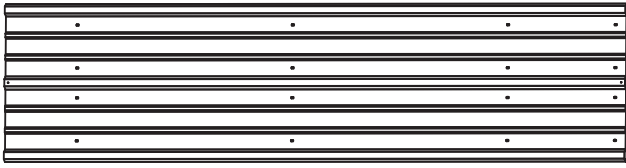

**PE3** X6

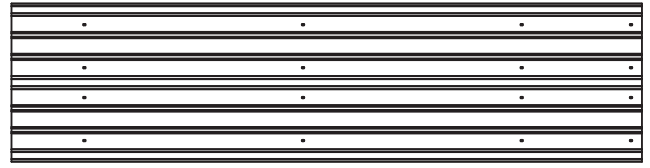

**PE4** X20

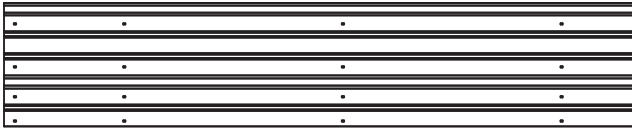

**PE5** X2

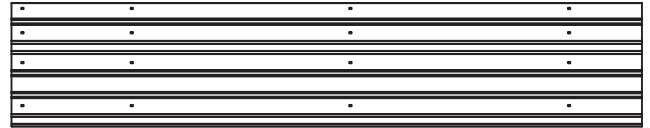

**PE6** X2

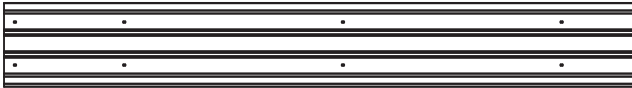

**PE7** X2

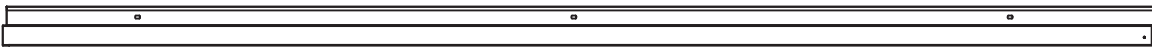

**M9** X2



**M10** X2

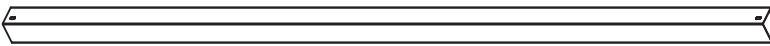

**M11** X2

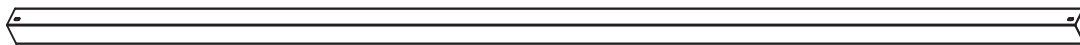

**M11A** X4

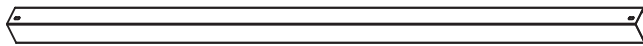

**M11B** X2

# STEP 1

REPEAT 3 TIMES

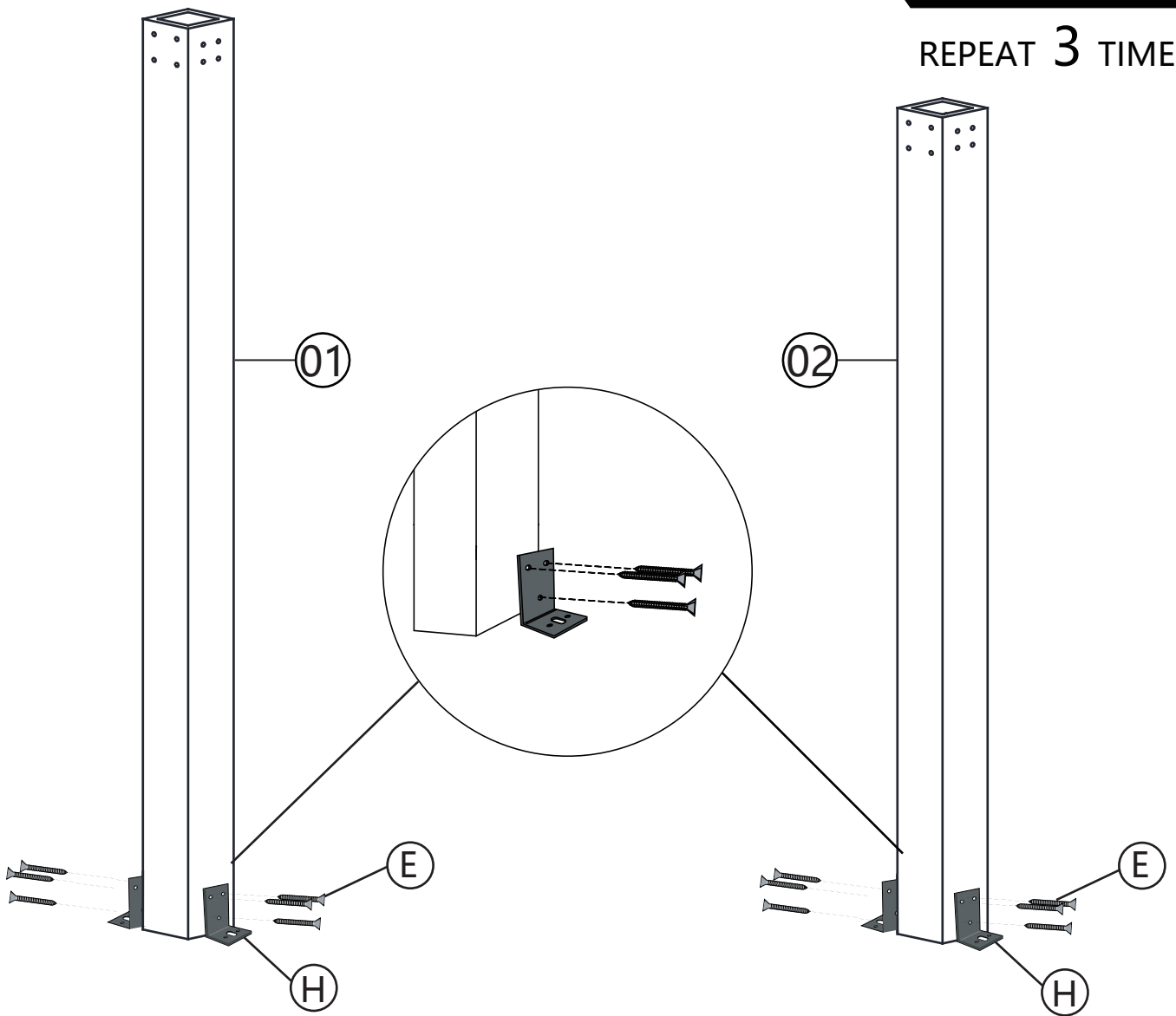

Attach the 4 parts "H" to parts "01" and "02" and tighten with 12 screws "E" .  
Notice: Repeat the above steps to connect the remaining part "01" and "02"  
and parts "H"

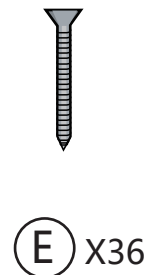
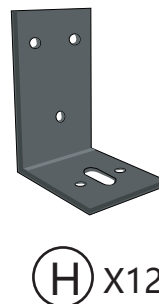
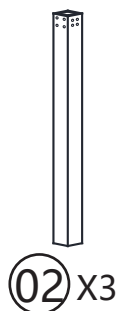
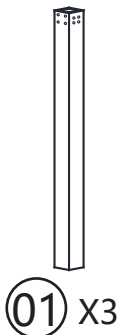

# STEP 2

REPEAT 2 TIMES

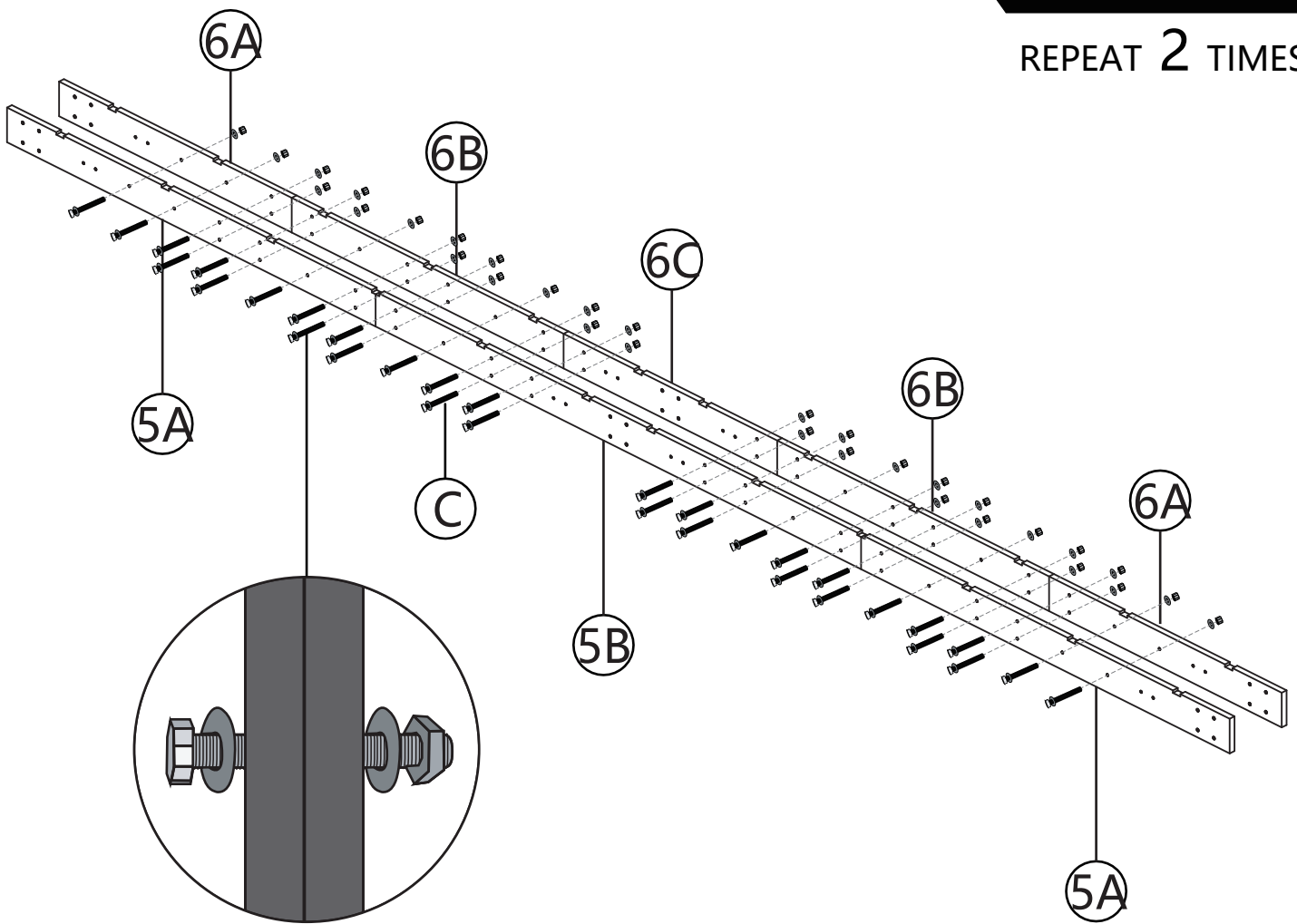

As shown in the figure ,overlap the assembled parts (6A-6B-6C-6B-6A) and (5A-5B-5A) and secure with 32 screws "C".

Notice: Repeat the above steps to connect the remaining parts.

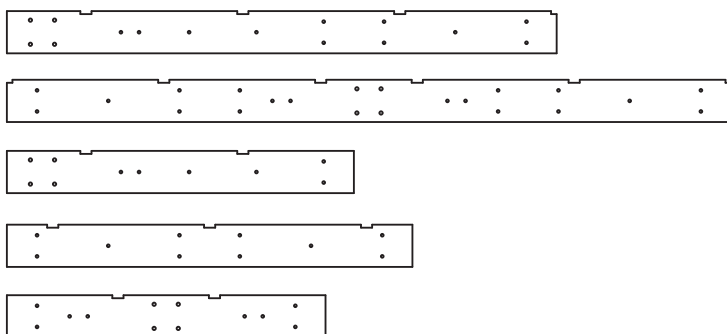

⑤A x4

⑤B x2

⑥A x4

⑥B x4

⑥C x2

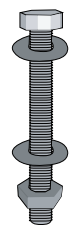

③ x64

# STEP 3

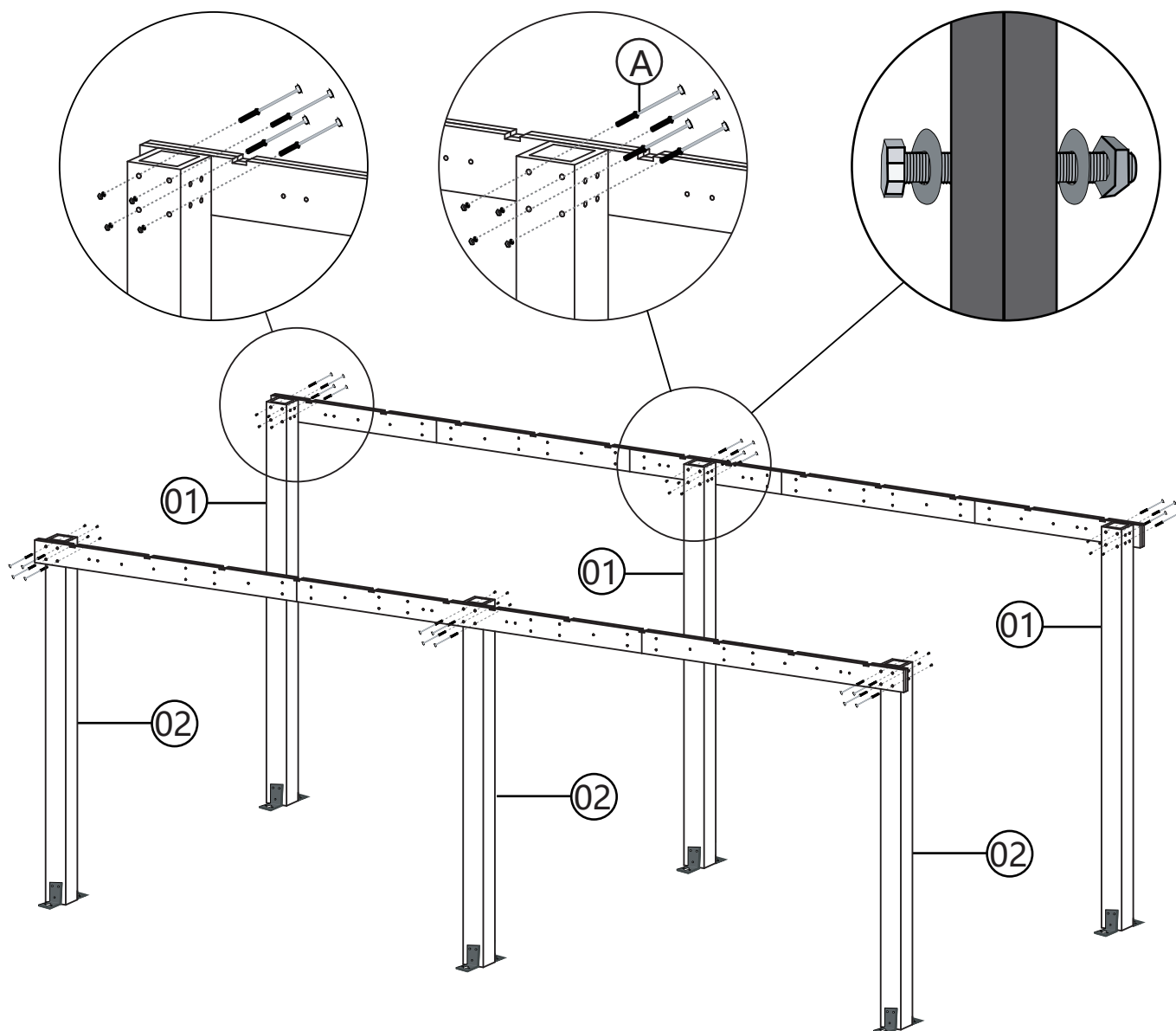

Attach the assembled parts "6A-6B-6C-6B-6A" /5A-5B-5A to parts "01" and "02" and secure with 24 screws "A" .

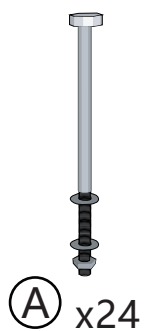

# STEP4-1

REPEAT 2 TIMES

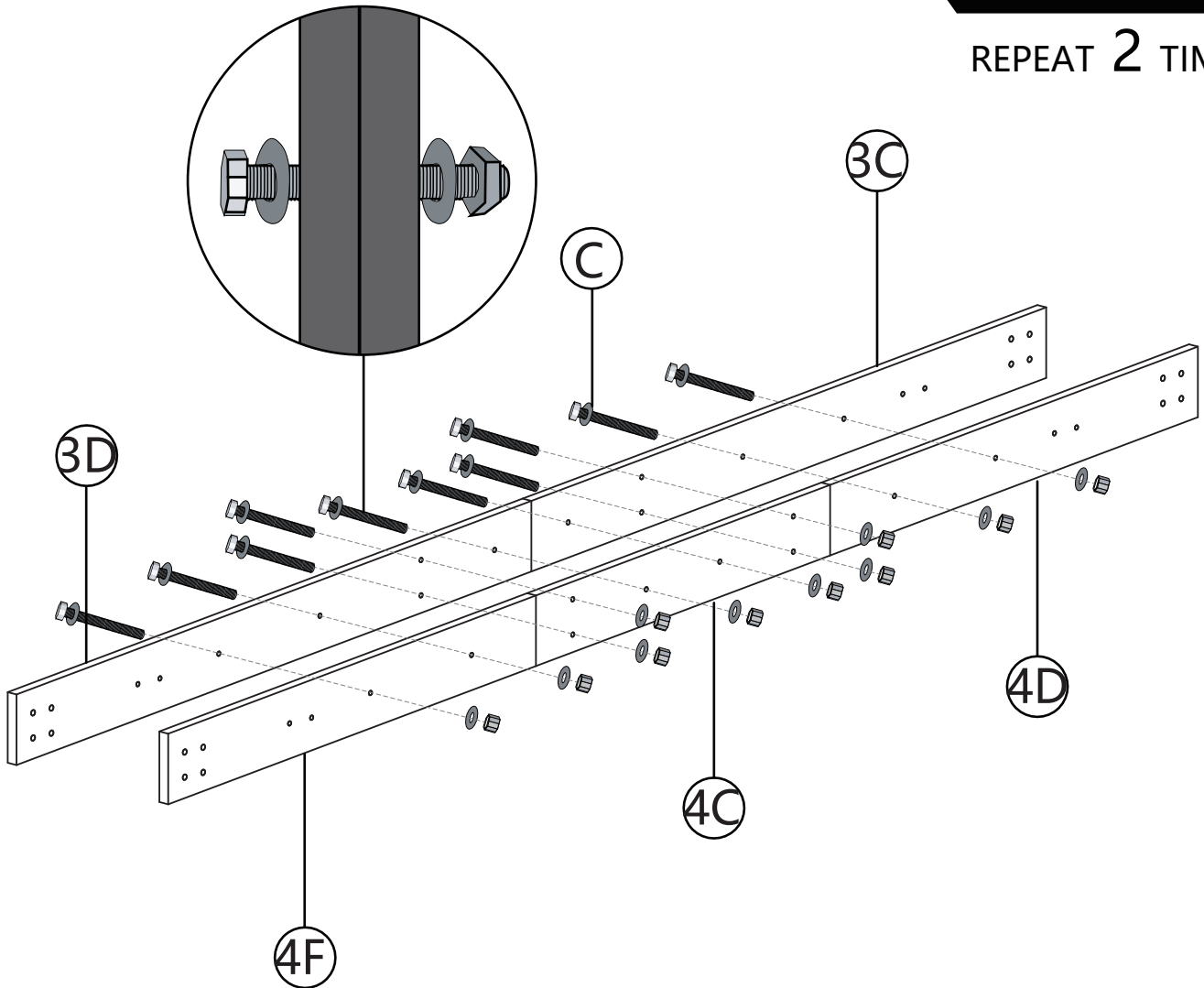

Place the connecting part "4C" in the middle of the connecting parts "4F" and "4D" (4F-4C-4D), and place the part "3D" and "3C" together (3D-3C). Connecting part "4F-4C-4D" and "3D-3C" with 10 screws "C". Repeat the above steps to connect the remaining parts.

Notice: The beveled edges of Part 3D and 4F must be oriented as shown when assembled.

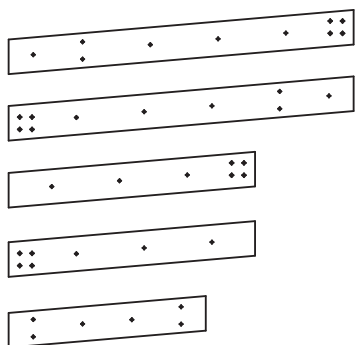

3C x2

3D x2

4D x2

4F x2

4C x2

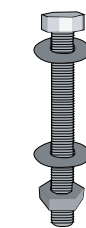

C x20

# STEP 4-2

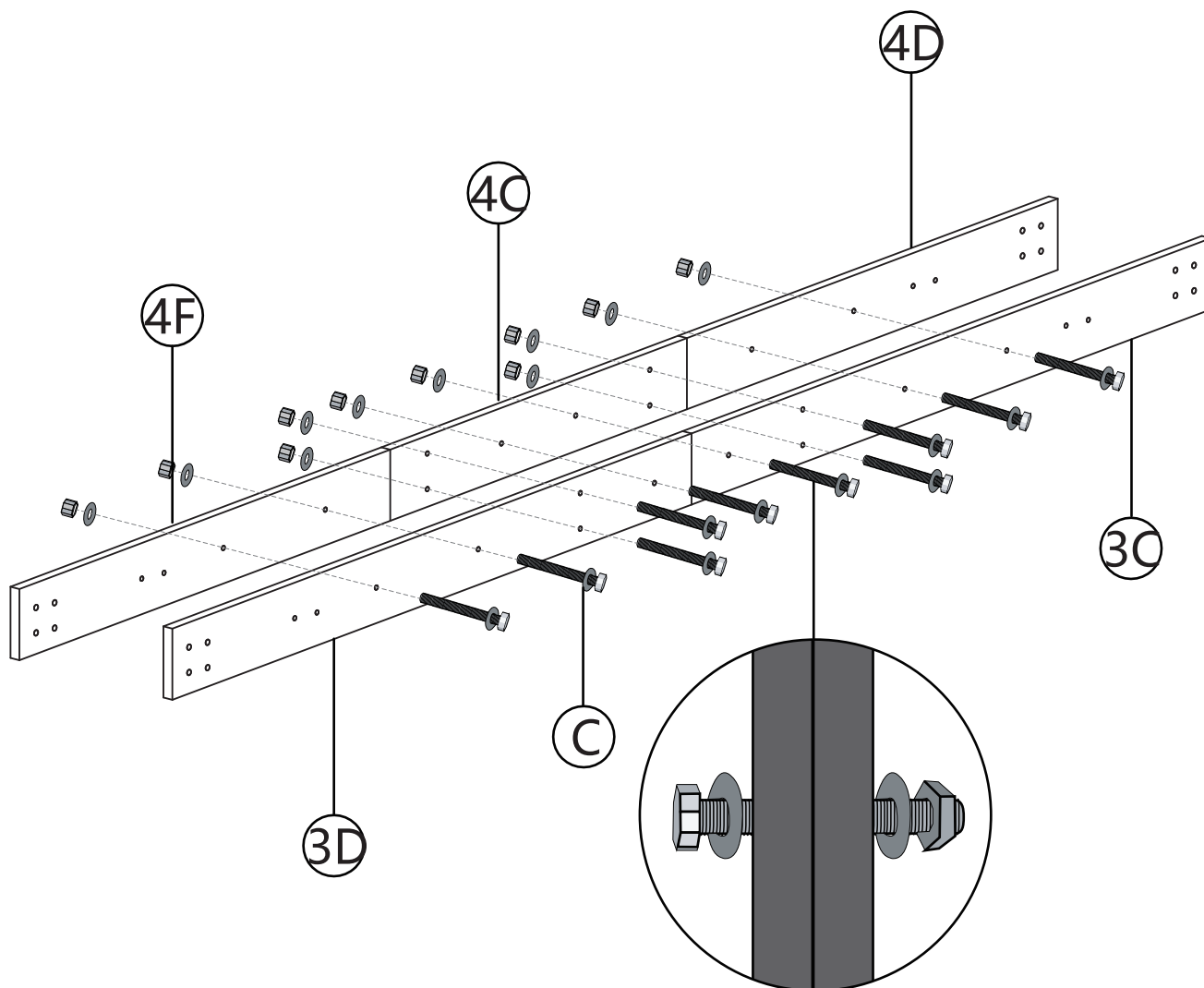

Repeat the 4-1 steps.

Notice: This time the screw is turned in the opposite direction of 4-1.

The beveled edges of Part 3D and 4F must be oriented as shown when assembled

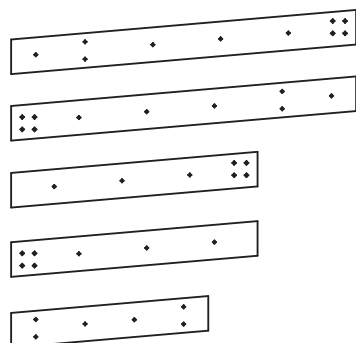

3C x1

3D x1

4C x1

4D x1

4F x1

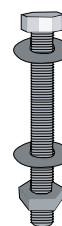

C x10

# STEP5

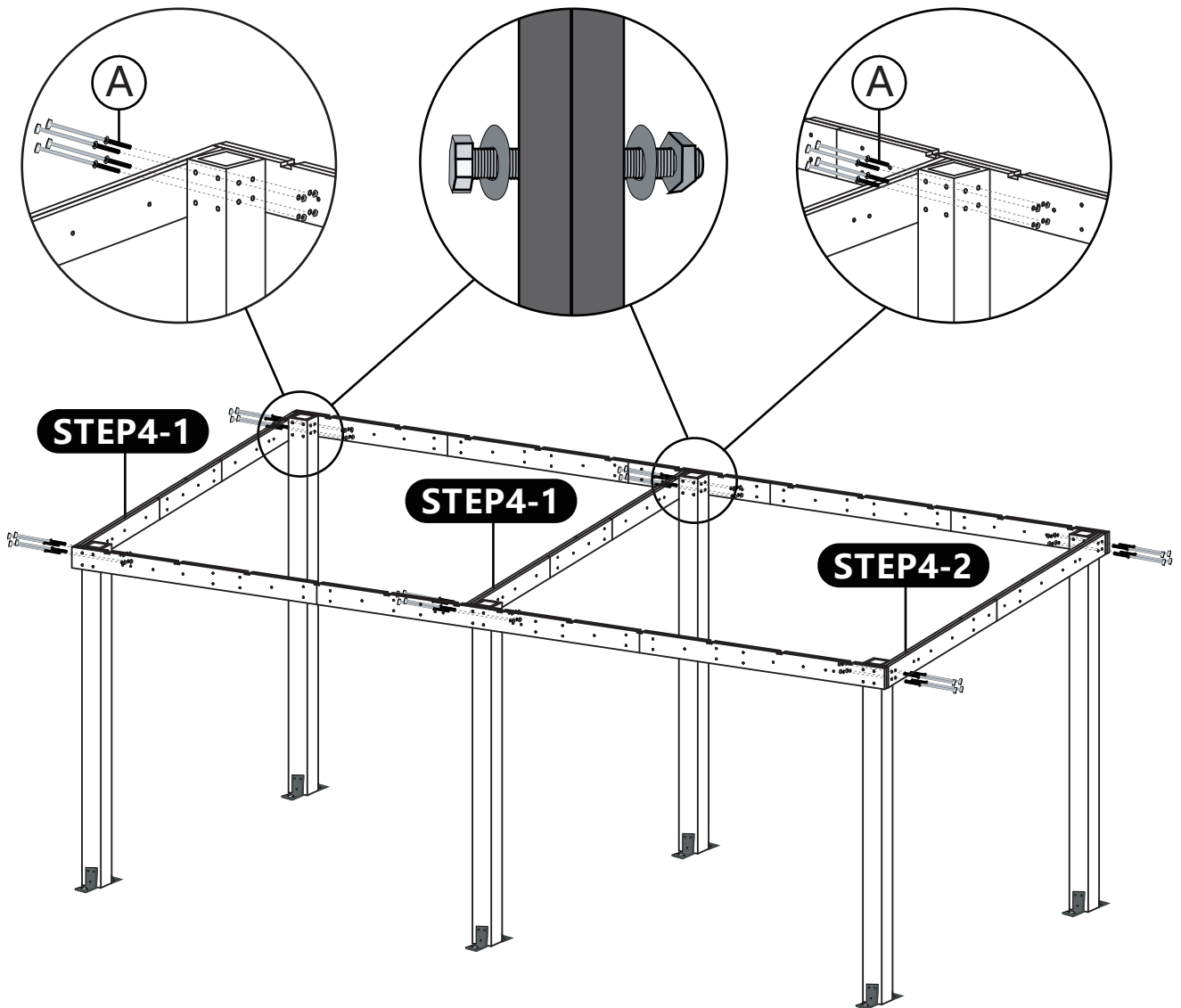

Attach the ends of part "step4-1" to the top of the parts "01" and "02" , using 8 screws "A" to connect the two sides.

Notice: Repeat the above steps to attach the remaining part "Step4-2" to the top of the parts "01" and "02" .

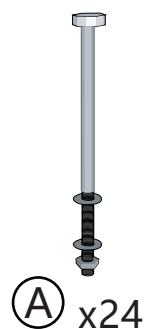

# STEP 6-1

REPEAT 12 TIMES

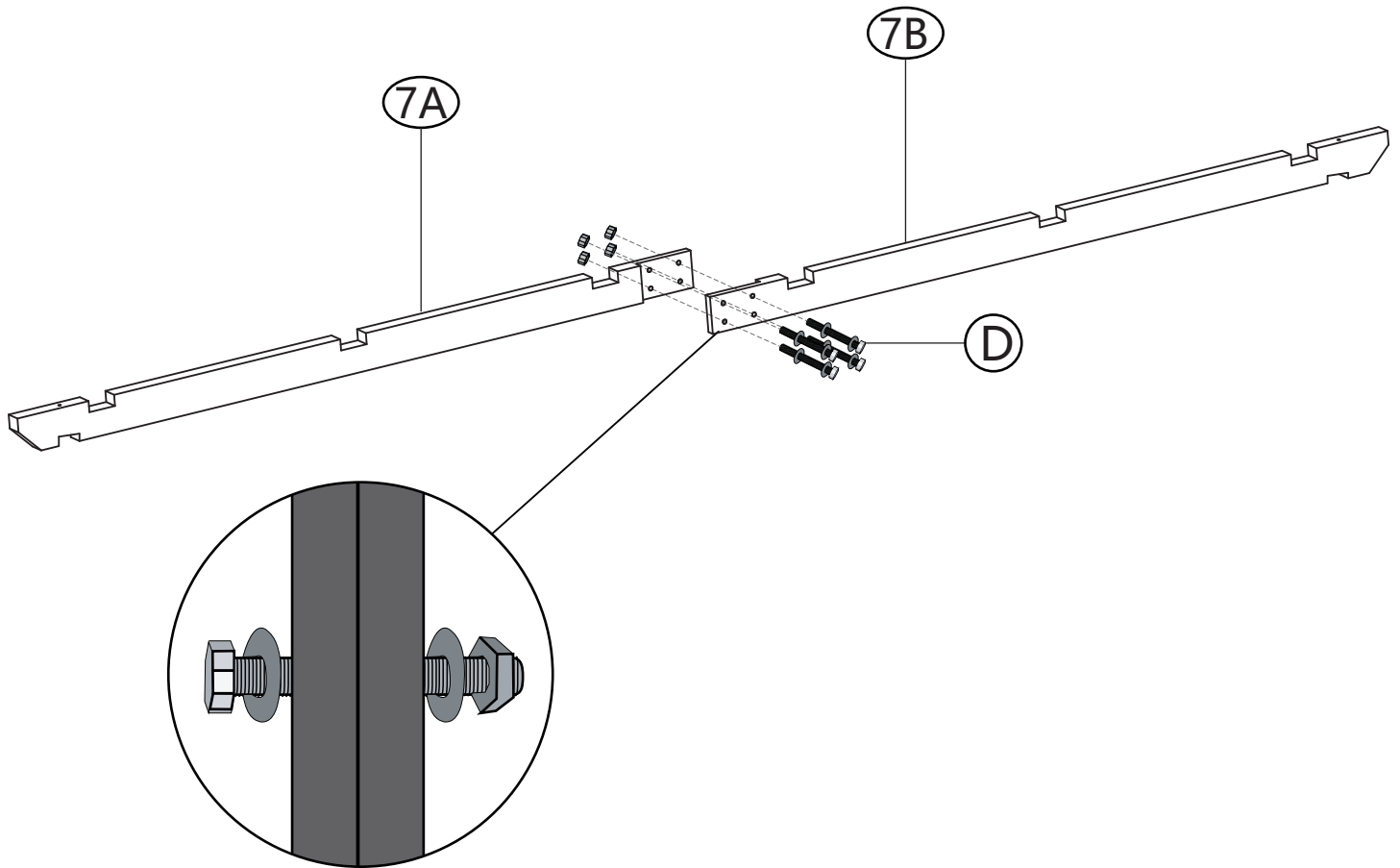

Connecting part "7A" and part "7B" with 4 screws "D"

Notice: Repeat the above steps to connect the remaining 11 parts "7A" and 11 parts "7B" .

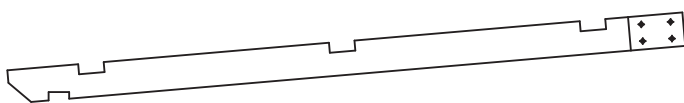

7A x12

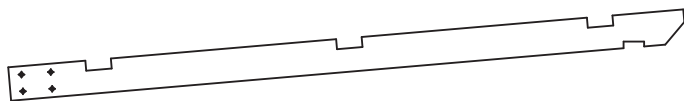

7B x12

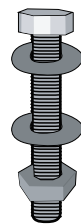

D x48

# STEP 6-2

REPEAT 12 TIMES

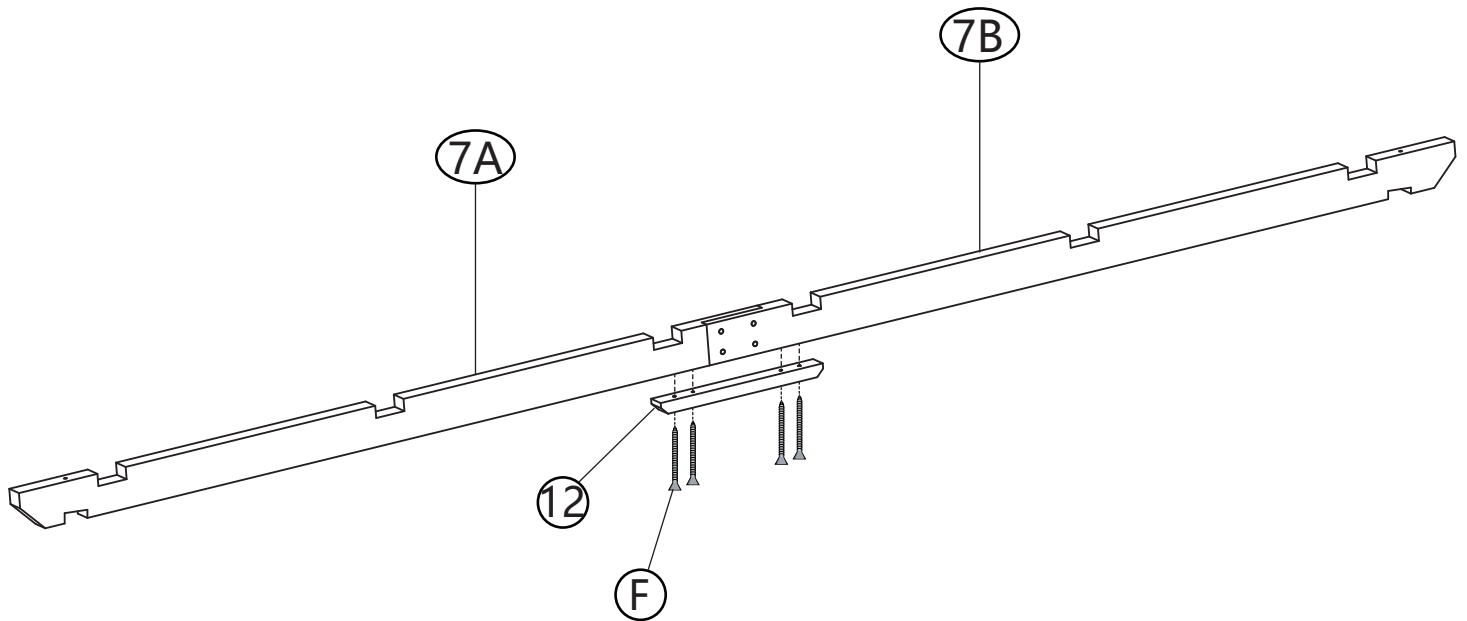

Attach part 12 to the connection of part 7A and 7B with 4 Screws F, with the connection aligned with the middle of part 12.

Notice: Screws F are self-tapping screws. There are pre-drilled holes on part 12 but not on part 7A and 7B.

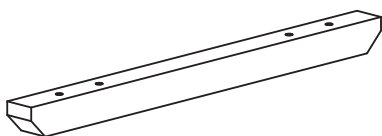

⑫x12

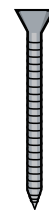

ⓕ x48

# STEP 7

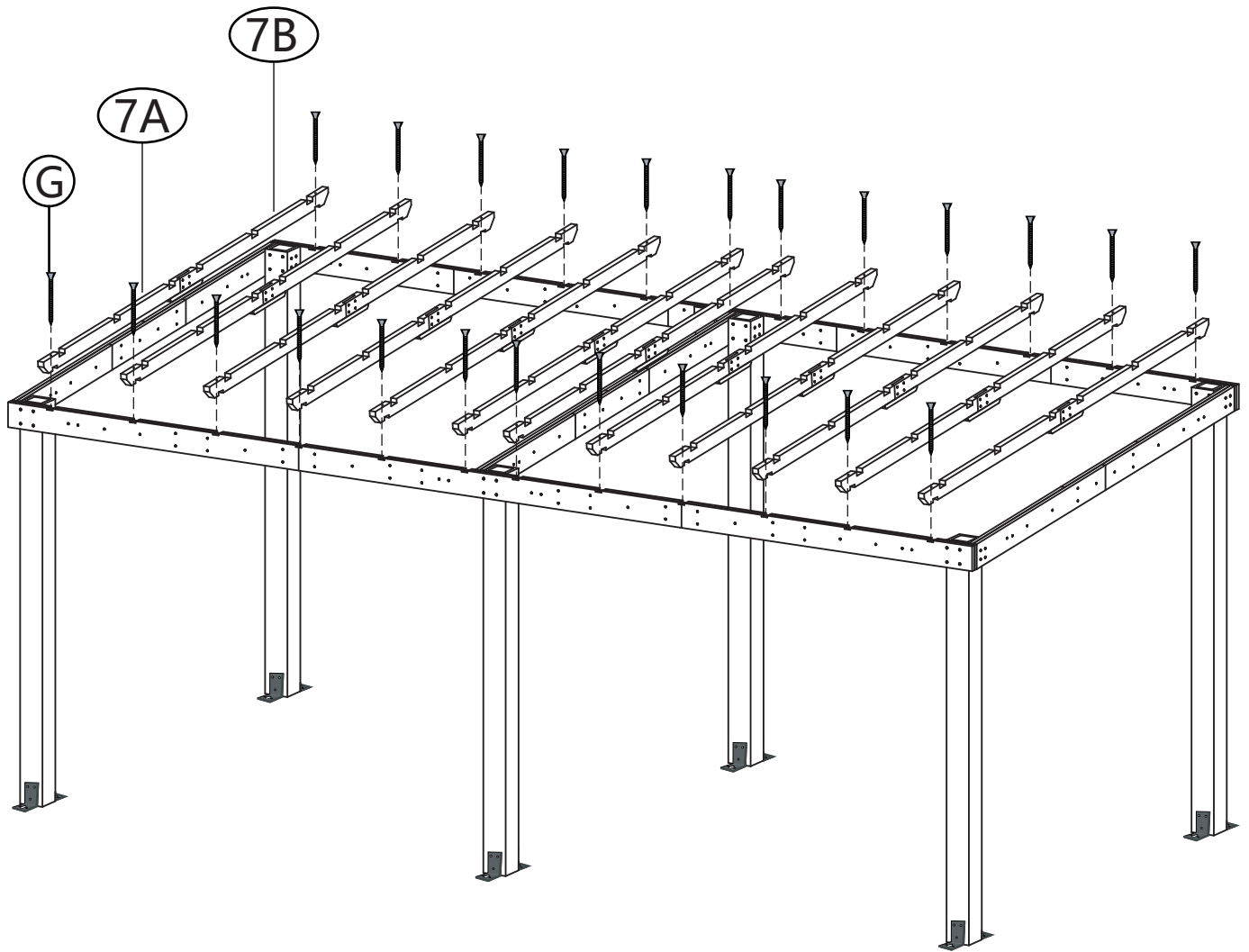

As shown in the figure, attach the 12 assembled parts "7A-7B" to the frame and tighten with 24 screws "G" .



Ⓒ x24

# STEP 8

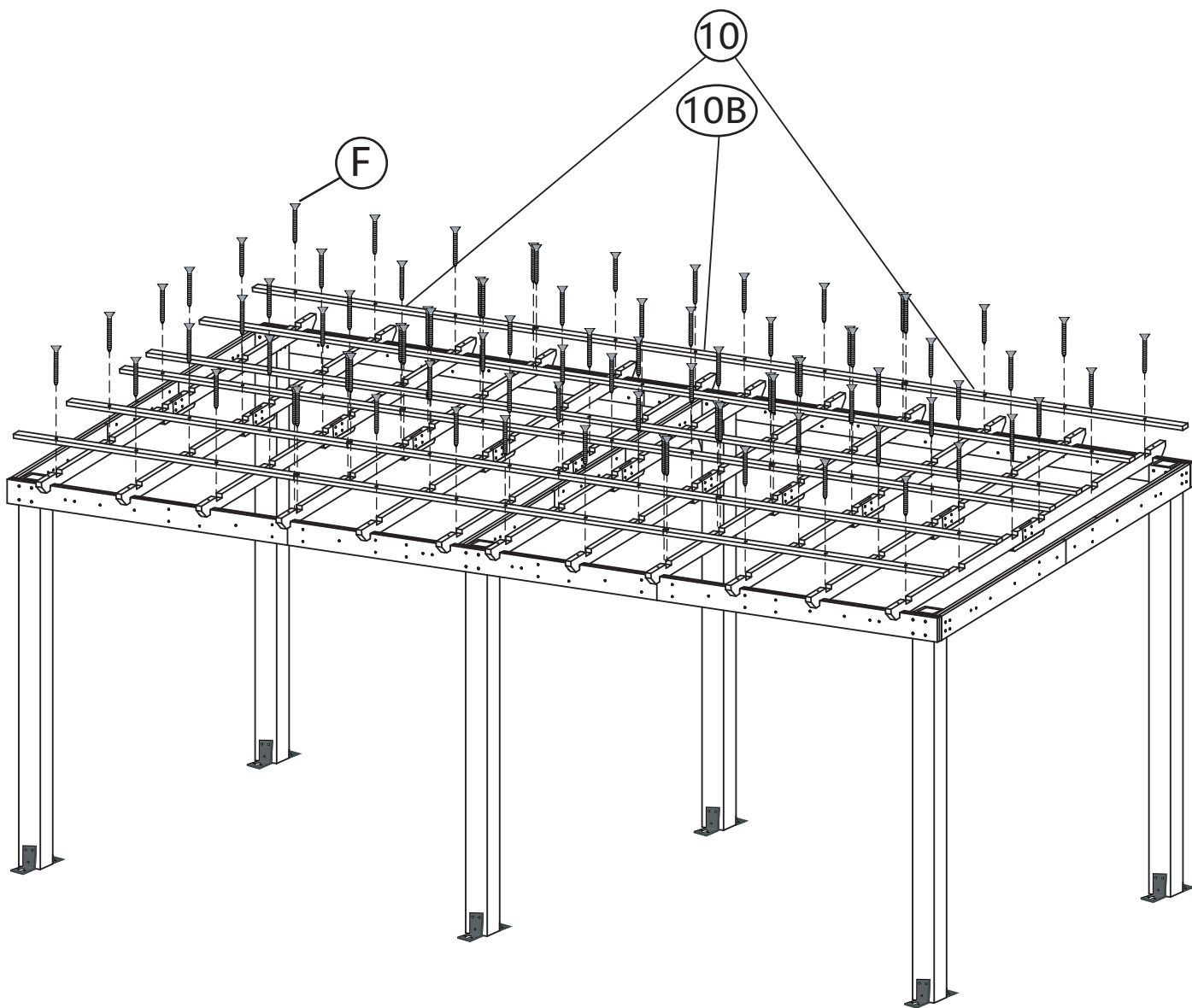

Place the 12 parts "10" and 6 parts "10B" on the top of the part "7A-7B" and tighten with 84 screws "F".



⑩ x12

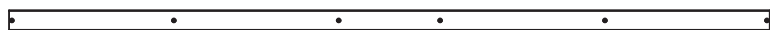

⑩B x6

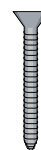

ⓕ x84

# STEP 9

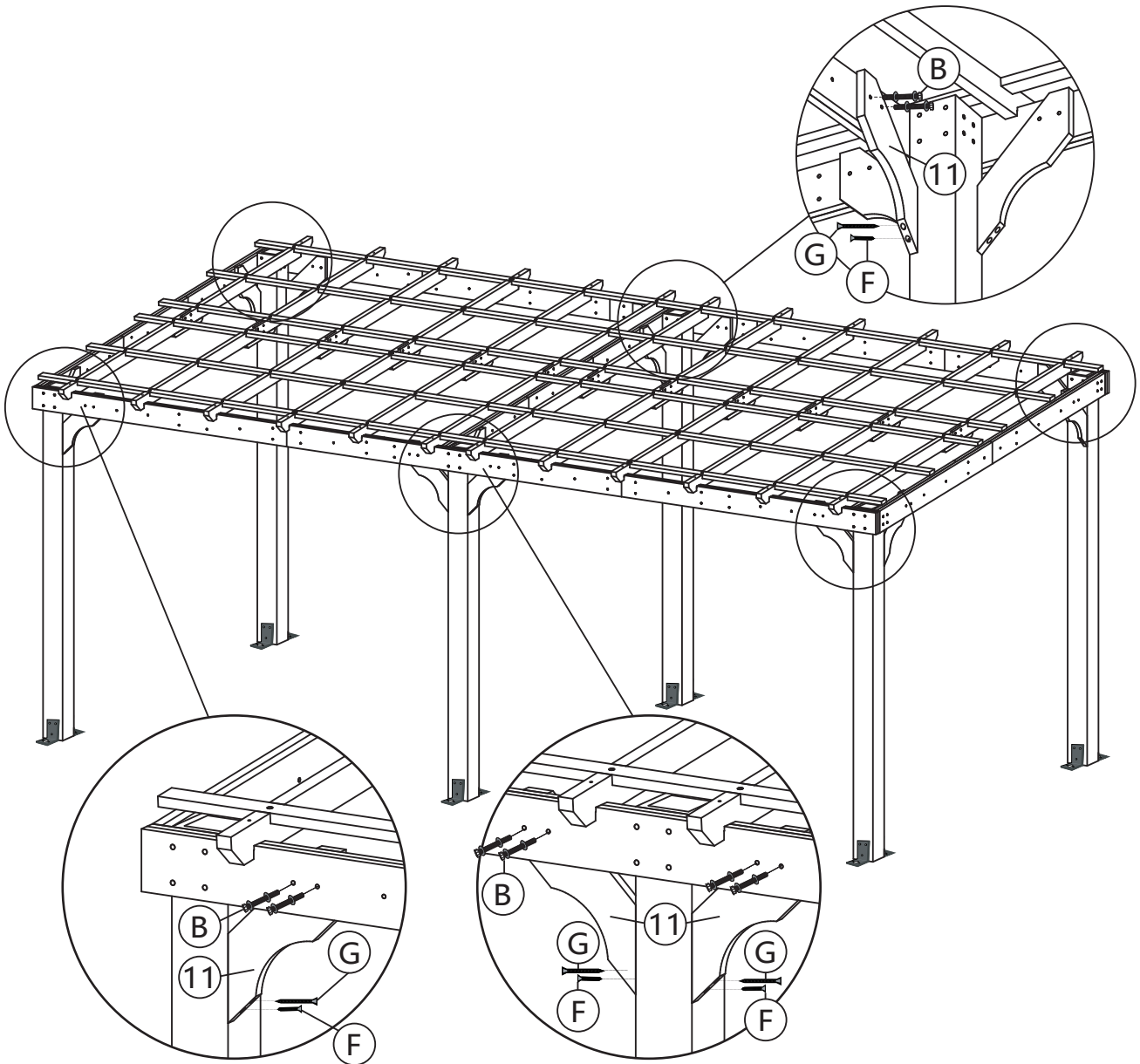

Attach the 14 parts "11" to the corner of the columns with 28 screws "B" ,  
14 screws "G" and 14 screws " F" .

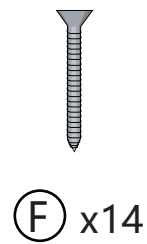
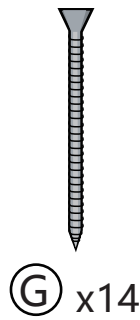
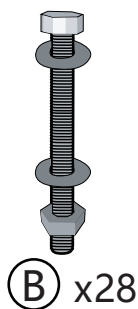
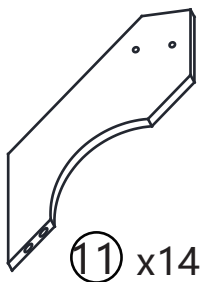

# STEP 10

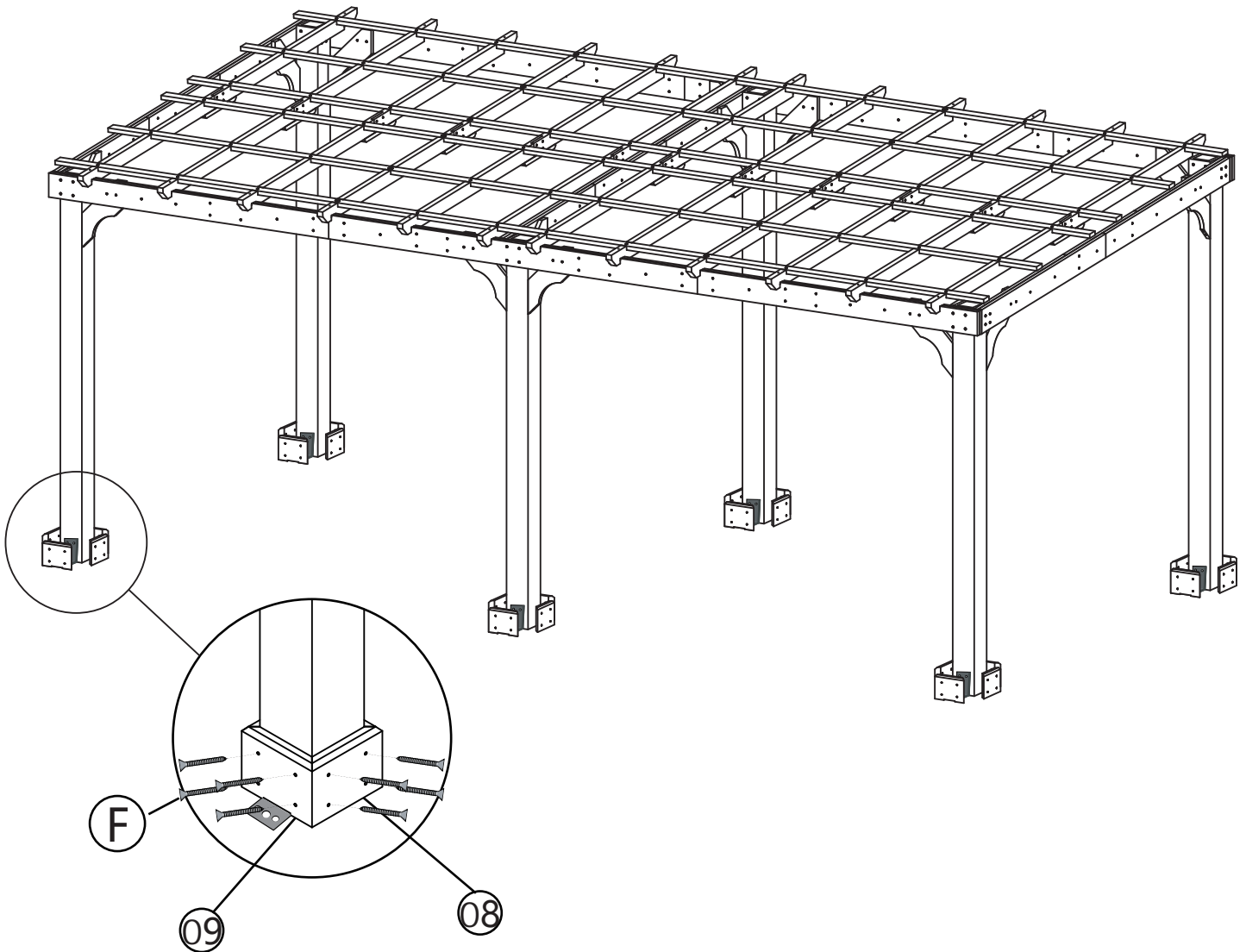

Attach the 12 parts "08" and 12 parts "09" to the bottom of the parts "01" and "02" and tighten with 96 screws "F" .



08 x12



09 x12

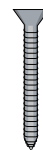

F x96

# STEP 11

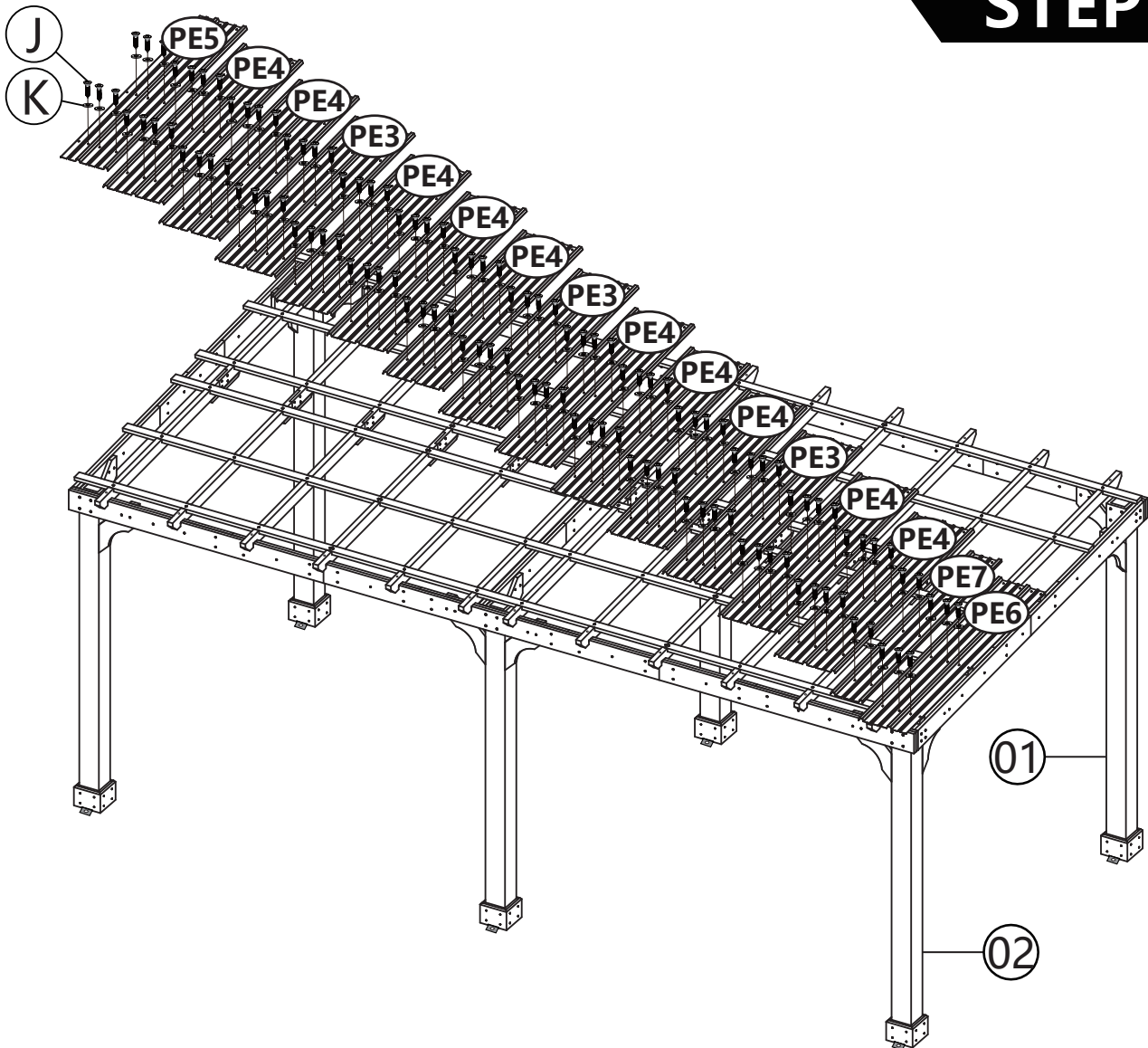

Place the 3 parts "PE3" , 10 parts "PE4" , 1 part "PE5" , 1 part "PE6" and 1 part "PE7" on the top of the frame in the order of the assembly drawing and tighten with 120 screws "J" and 120 screws washers "K" .

Notice: The iron sheet must be placed in the same position as shown in the assembly drawing.

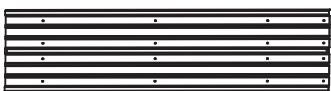

**PE3** X3

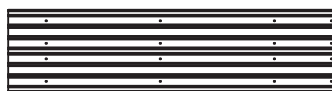

**PE4** X10



**PE7** X1



**PE5** X1



**PE6** X1



**J** X120



**K** X120

# STEP 12

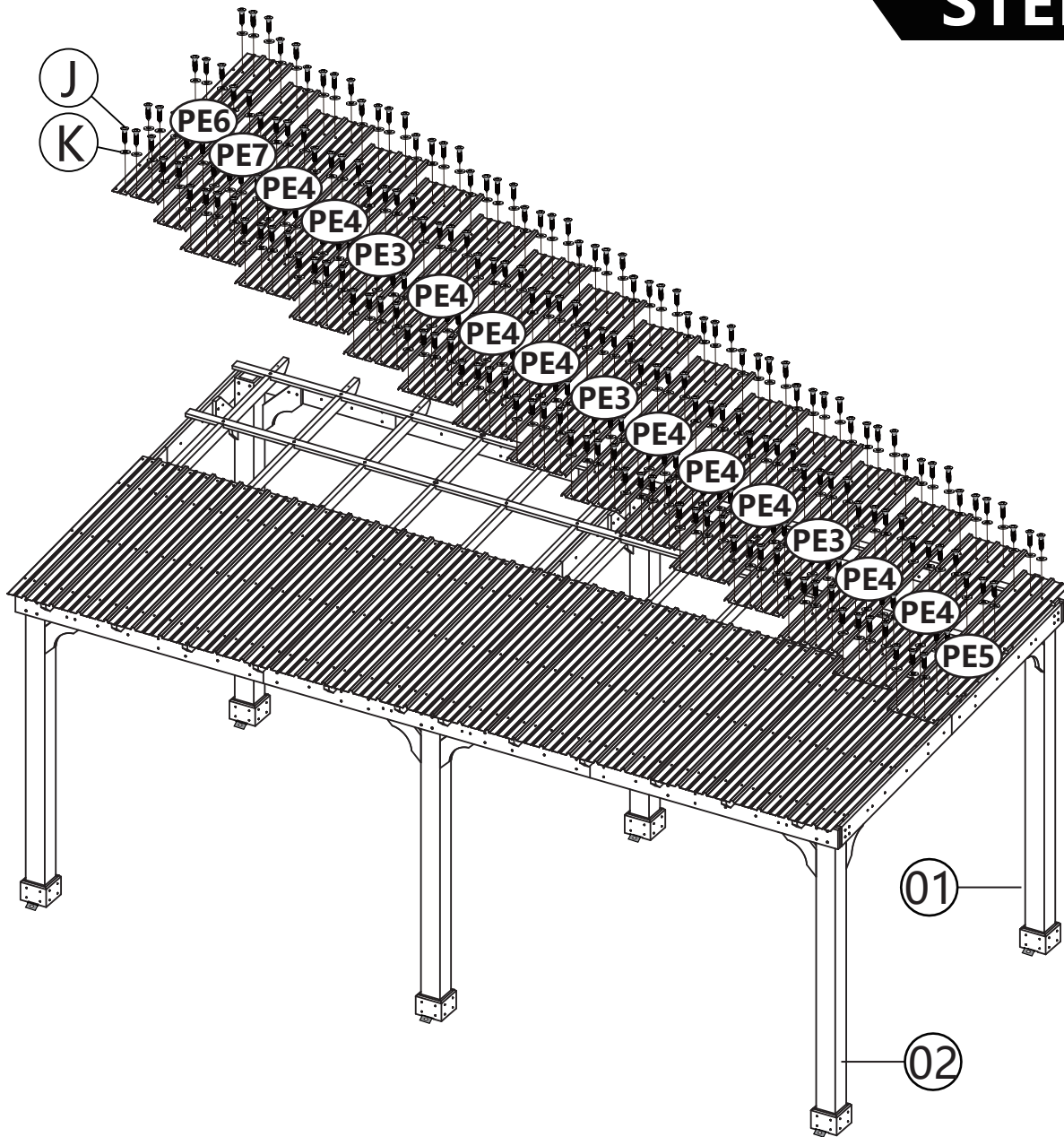

Similarly, place the 3 parts "PE3" ,10 parts "PE4" , 1 part "PE5" , 1 part "PE6" and 1 part "PE7" on the top of the frame in the order of the assembly drawing and tighten with 240 screws "J" and 240 screws washers "K" .

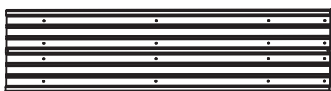

PE3 X3

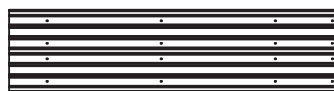

PE4 X10



PE7 X1



PE5 X1



PE6 X1



J X240



K X240

# STEP 13

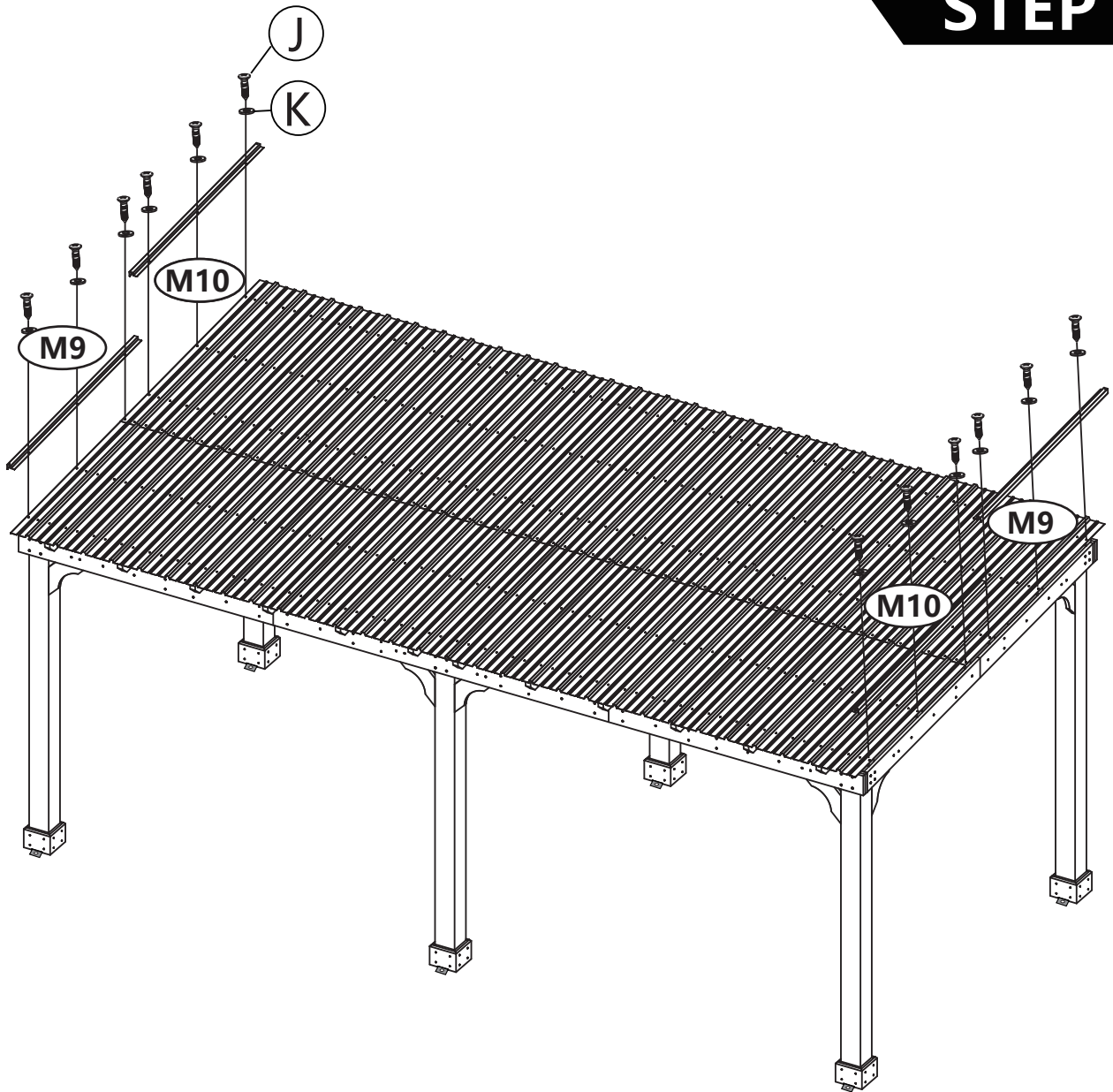

Place the 2 parts "M9" and 2 parts "M10" on the sides of the frame and secure with 12 screws "J" and 12 screws washers "K" .



**M9** X2



**M10** X2

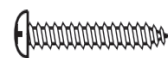

**J** X12



**K** X12

# STEP 14

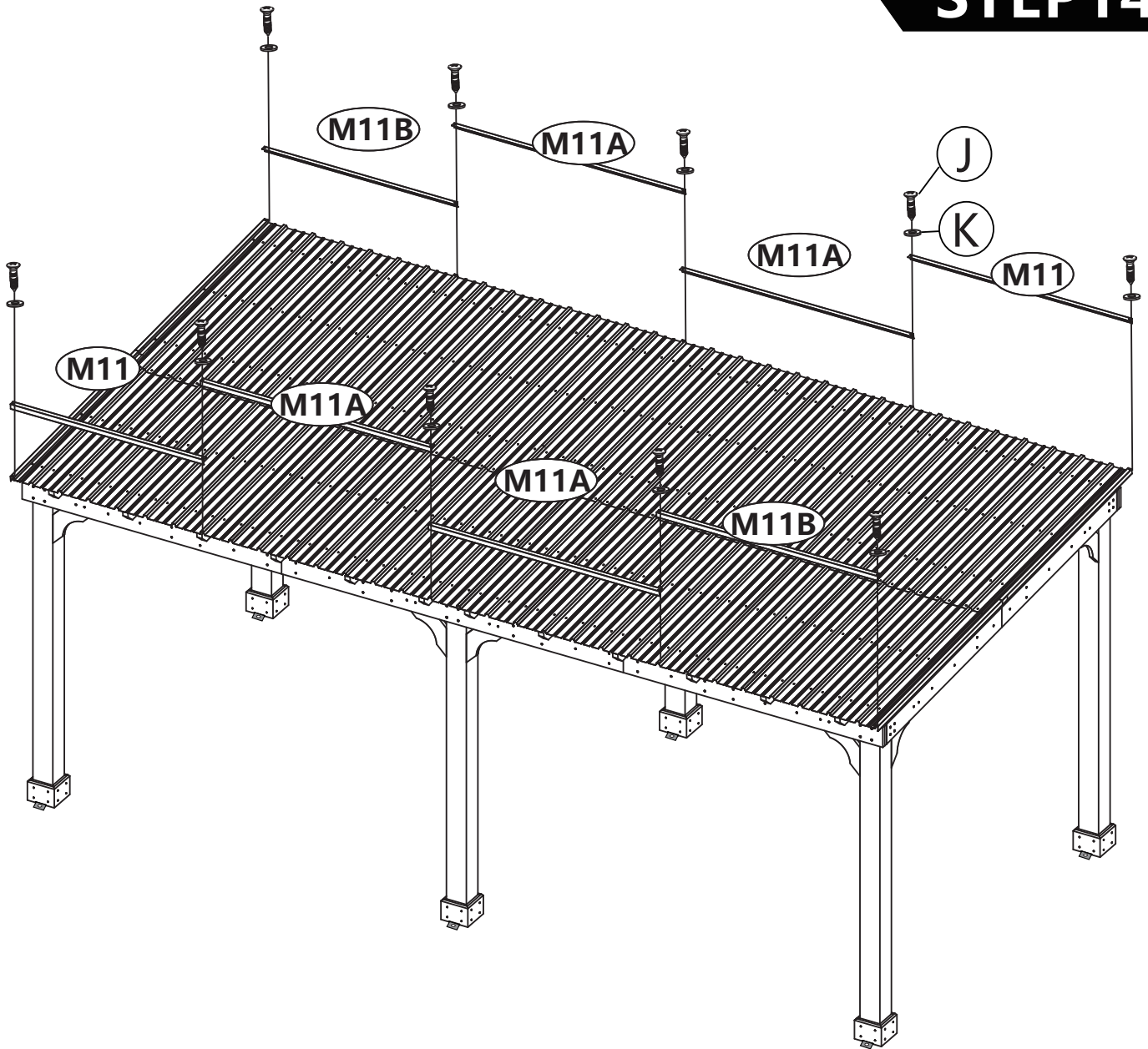

Place 2 parts "M11", 4 parts "M11A" and 2 parts "M11B" on the remaining sides and secure with 10 screws "J" and 10 screws washers "K".



**M11** X2

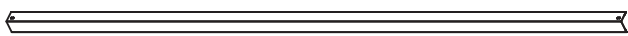

**M11A** X4



**J** X10



**K** X10



**M11B** X2

# STEP 15

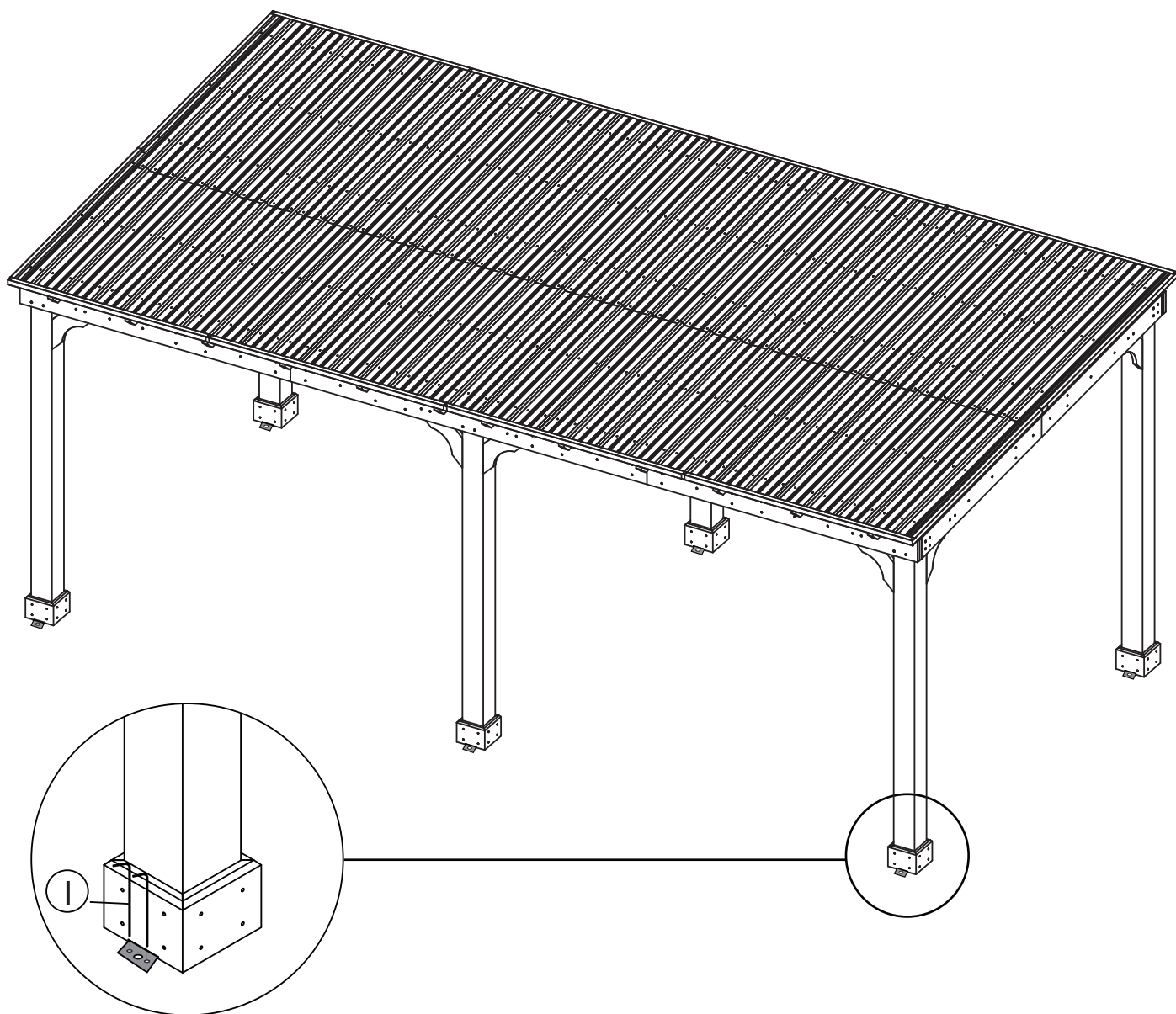

Insert the parts "I" into the hole of the parts "H" to make the product stronger.

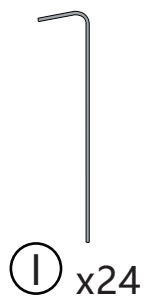

# Enjoy your products!

