

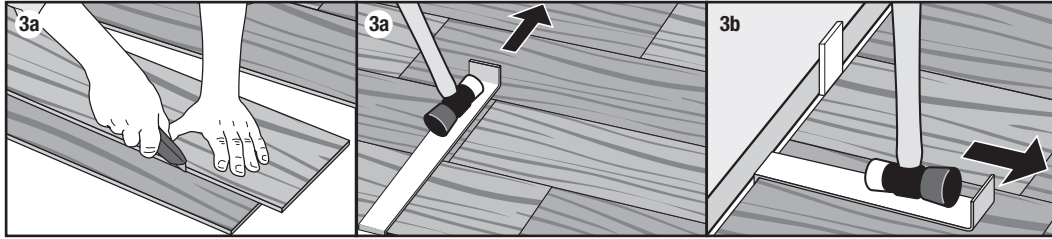

**3. INSTALLING THE LAST ROW**

- For the last row, align the plank to be used on top of the 2nd to last row. Using a full width plank as a spacer, trace the wall contour. Use a full plank as a straight edge to cut the plank. Insert the long edge tongue into the long edge groove and use a pull bar and hammer to close the gap.
- After tapping the long side joint closed, close the short edge joints using a tapping block or pull bar.



**4. INSTALLING UNDER DOORWAY FRAMES**

- When the new flooring meets a threshold or a doorway, we recommend undercutting the door jamb. To secure the right cut, turn a plank upside down and place it on the floor up to the door frame. Then place a reciprocating saw flat against the plank and simply cut through the frame. Remove the cut-out piece and vacuum away debris. Slide the plank under the pre-cut door frame. Door frame should be cut so that a 1/4 in. (6 mm) gap is located from the edge of the plank under the casing to the wall.
- Tap the long side joint closed first, then tap the end joint closed.

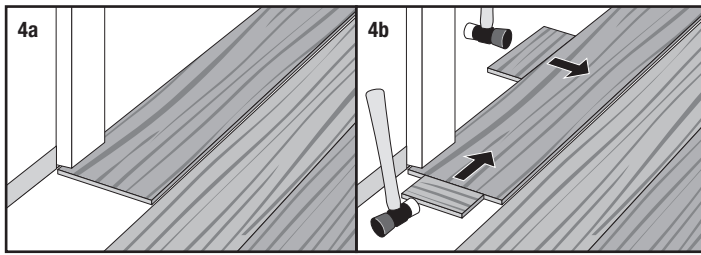

**5. INSTALLING AROUND FIXED OBJECTS**

- Allow 1/4 in. (6 mm) expansion space around pipes or other fixed objects.
- In rows where there is a pipe, make sure the pipe falls exactly in line with the short side of two planks. Select a drill bit with the same diameter as the pipe plus 1/2 in. (13 mm). Click the planks together on the short side and drill a hole centered on the joint between the two planks. Then install the planks.
- For a double pipe, drill a hole equivalent to the diameter of the pipe plus 1/2 in. (13 mm) at each of the marked points. If located on the long side of the plank, make a 45° cut from each hole to the edge of the plank. Then, using an appropriate glue along the cut edges of the piece you cut out, glue the piece in place. Be sure no glue comes between the cut-out piece and the subfloor.

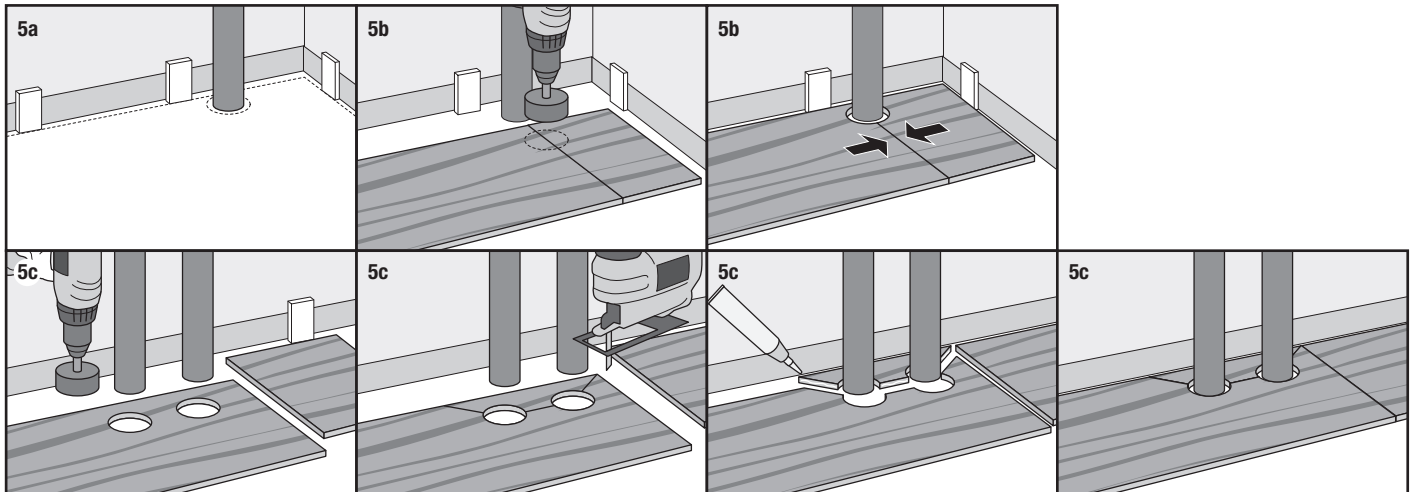

**6. FINISHING THE INSTALLATION**

- Remove all spacers.
- Fill any expansion spaces around potentially wet areas (such as refrigerators, tubs, etc.) with premium, waterproof 100% silicone caulk.
- Remember, the use of coordinating T-Molds is required when installing flooring in a room or area that is larger than 100 lineal feet (30.5 meters) in any direction, so that the floor is separated into sections that are no larger than 100 ft. x 100 ft. (30.5 meters x 30.5 meters) per section.
- Install moldings to cover the expansion gap. When installing moldings, never allow nails or screws to enter the flooring or the expansion zone around the flooring perimeter. All moldings and transition strips need to provide a 1/4 in. (6 mm) expansion space as well.

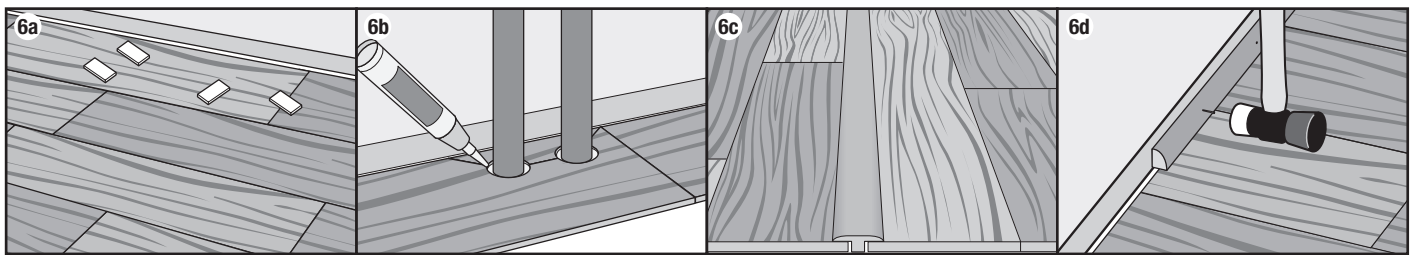

Note: Coordinated moldings can be purchased on homedepot.com. Follow molding installation instructions for proper installation.

**NOTE:** Rooms larger than 1500 sq. ft. (50 ft. x 30 ft.) require the use of coordinating T-molding transitions. Doorways and archways less than 4 ft wide also require the use of T-molding transitions.

**NOTE:** Save any leftover planks/tiles. Do not discard as they are color matched (dye-lot) to your floor. They can be used for replacement in the event you need to replace a plank/tile in the future.

**Accessories**

Pictures are for general illustrative purposes only. Actual products may differ from pictures.

- Clean the floor.
- Install or reinstall all wall trim pieces. Nail them through the wall, but not to the subfloor to avoid restricting the expansion gap.
- Install transition trim pieces. Nail them to the subfloor, not the flooring.
- At doorways, transitions should be used to protect the edges of the floor and to provide a decorative transition from one floor type to another.
- If the floor is to be covered, use a breathable material such as cardboard. Do not cover with plastic.

**T-Molding:** Used to create a transition between floor coverings of similar heights or to cover an expansion gap.

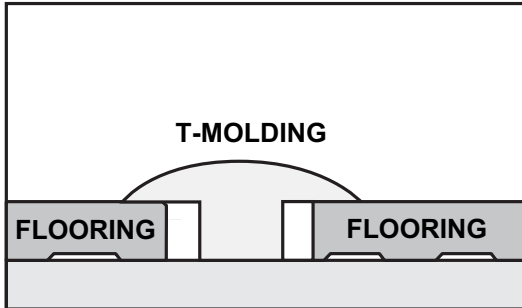

**Stair Nose:** Used in conjunction with flooring installed on stair steps or finished edges of a higher level floor like in a sunken living room.

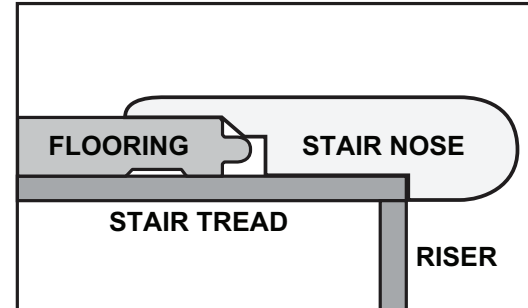

**Hard Surface Reducer:** Used to transition to another hard surface flooring of different heights such as tile, vinyl, or concrete.

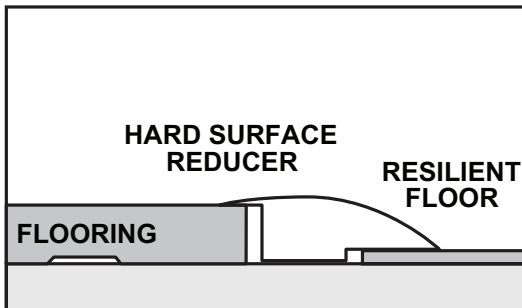

**Quarter Round:** Used to cover the expansion space between the wall base and your flooring. It can also be used to make smooth transitions between the floor and cabinetry. It can be used with or without wall base molding. Ensure you nail the quarter round to the wall and not the flooring, as shown.

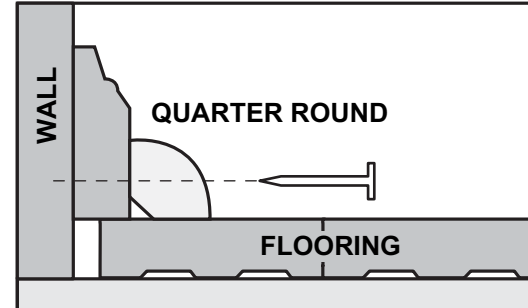

**Care and Maintenance**

**DAILY MAINTENANCE**

- Sweep, dust, damp mop, or vacuum your floor regularly to remove any particles that could cause abrasion or scratch your floor.

**CAUTION:** Vacuums with a beater bar or power rotary brush head can damage a floor and should never be used.

- Use a damp mop to remove spots and soil. Use any high-quality, pH-neutral vinyl cleaner. Alternatively, use a non-rinsing, biodegradable cleaner that leaves no residue or haze.
- Do NOT use detergent based cleaners.
- Do NOT use an abrasive mop and shine products.
- Do NOT ammonia or bleaches.
- Do NOT use steel wool or scouring powder which will scratch the floor.
- Do NOT use any dust cleaners, as they may cause your floor to become slick or damage the finish.
- Avoid spills of paints, dyes, or harsh chemicals.
- Avoid long term exposure to direct sunlight. Use window treatments or UV tinting on windows.

**BRANDED OR OFF-THE-SHELF FLOOR CARE PRODUCTS**

If none of the above are effective and you choose to use a store bought product, test the product in a non-conspicuous area (i.e., closet, corner, or scrap pieces) for potential adverse side effects.

**PREVENTATIVE MAINTENANCE**

- Protect your floor when using a dolly for moving furniture or appliances. Protective sheets and/or plywood may be needed. Never slide or roll heavy furniture or appliances across the floor.
- Use flat floor protectors (nylon or felt) on all furniture legs. Clean protectors periodically to remove grit that may become embedded and cause scratching.
- Avoid excessive exposure to water from being tracked in during periods of inclement weather.
- Minimize abrasive material and dirt by placing mats on both sides of exterior doors and by using area rugs in high-traffic areas
- Rearrange furniture and rugs periodically to avoid uneven color and shade changes from light exposure.
- Use protective mats beneath rolling chairs and keep furniture casters clean.
- Use NON-RUBBER backed mats at all entrances to reduce the walk-off residue from asphalt driveways as well as prevent dirt and grit from being tracked onto your floor. Rubber backed mats can discolor your floor.
- We recommend the use of a hard surface (non-studded), non-rubber chair mat to protect your floor from office chairs with casters. Light, rolling furniture should be outfitted with broad-surface, non-staining casters that have been engineered for hard surface floors. Such casters should be a minimum of 1 in. (2.5 cm) wide and at least 2 in. (5.1 cm) in diameter.
- Keep pets' nails trimmed.
- Remove shoes with cleats, spikes or exceptionally pointy heels before walking on the floor.