

Installation Instructions

The Lexington Mailbox and Post Kit

Model: PP350

RECOMMENDED TOOLS & SUPPLIES:

- POST HOLE DIGGER
- LEVEL
- PHILIPS HEAD POWER SCREWDRIVER
- PRESSURE TREATED 4" x 4" x 72" WOODEN POST* (Not Included)

PARTS LIST:

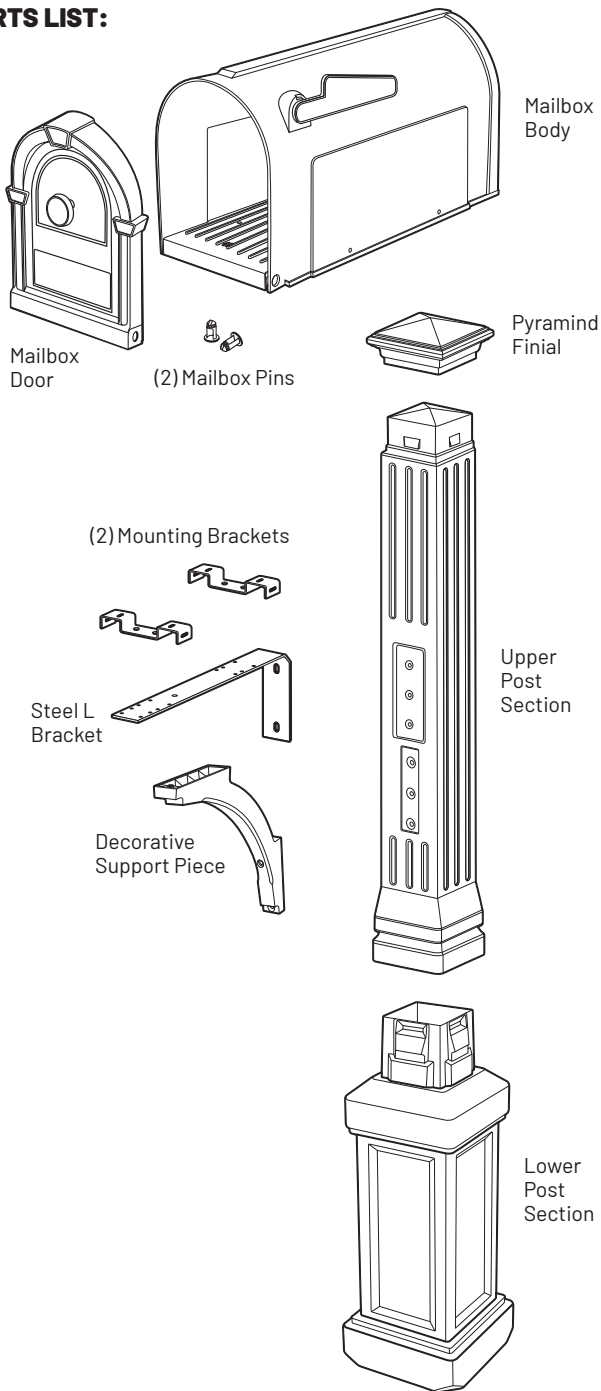

⚠️ WARNING: "Call Before You Dig" – Dial 811.

811 is the designated "call before you dig" phone number that directly connects you to your local One Call center. Each state has different rules and regulations governing digging to insure that buried utility lines will not be disturbed.

HARDWARE:

Shown at actual size

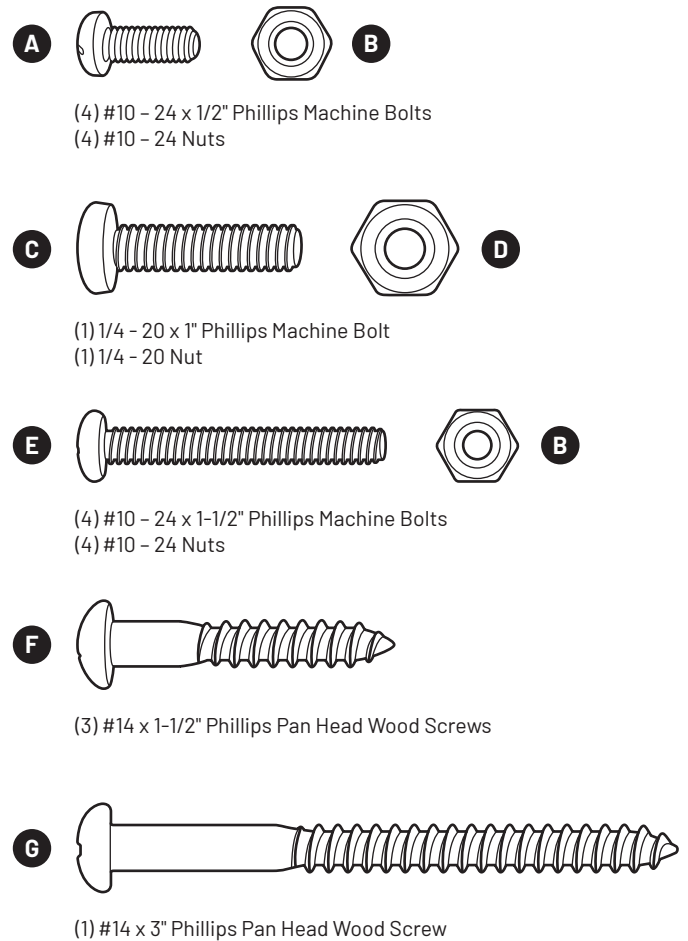

*Actual Diameter of a Standard 4" x 4" Pressure Treated Post: 3-1/2" x 3-1/2"

PLEASE NOTE: Concrete may be needed if installing in loose soil

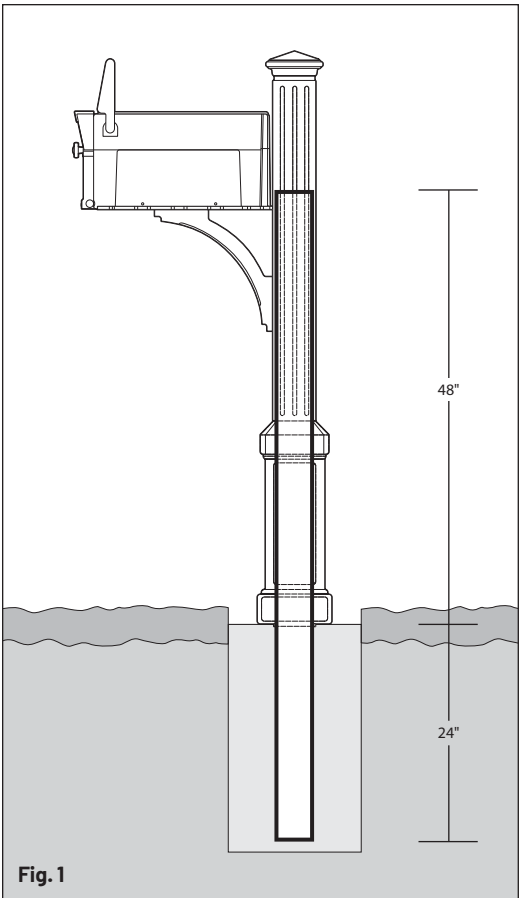

STEP 1 Determine location for mailbox. Using post hole digger, dig a hole 24" in depth. Install treated pine post by burying 24" of the post in the ground - leaving 48" of post above ground. Using a level, make sure post is perfectly vertical before packing soil / adding concrete to permanently secure post into position.

⚠ IMPORTANT: The pressure treated wood post **MUST** extend up into the Lexington Post a minimum of 48" as shown on Fig 1. When completing installation steps 3 and 4 (attaching Steel L Bracket and Decorative Support Piece), the screws must self-tap through the wall of plastic and then drill into the wood post in order to fully stabilize the product.

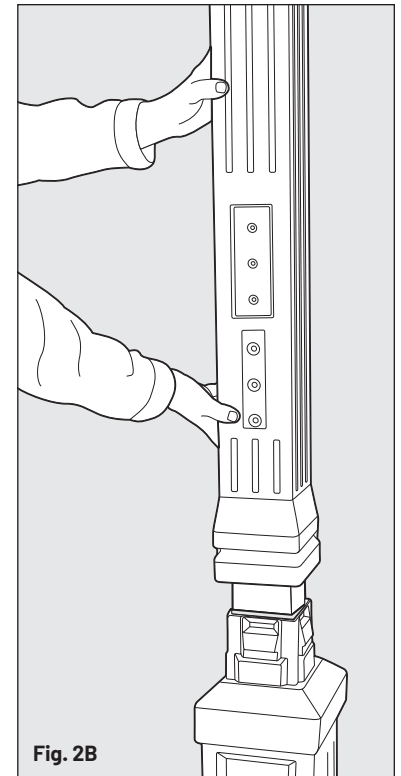
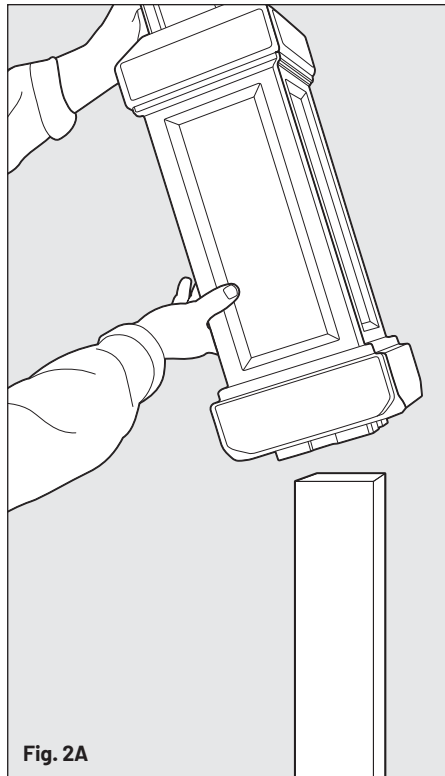

STEP 2 Slide the Lower Post Section over the wooden post. **NOTE:** there is not a "front" to this section, so it does not matter what side is facing the street. Secondly, slide the Upper Post Section over the wooden post. **NOTE:** make sure the side with the part / screw pattern (shown in Fig. 2B) is facing the street. Press the Upper Section onto the Lower Section until the two components snap together completely.

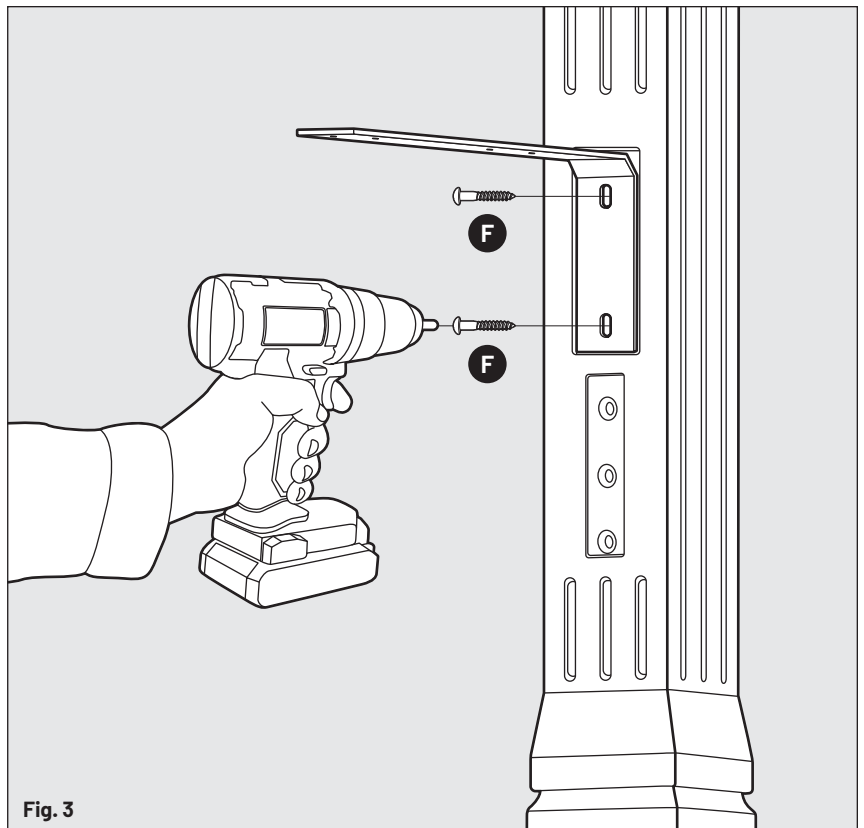

STEP 3 Attach the Steel L Bracket to the Upper Post Component using the (2) #14 x 1-1/2" Pan Head Screws **F** included in the kit.

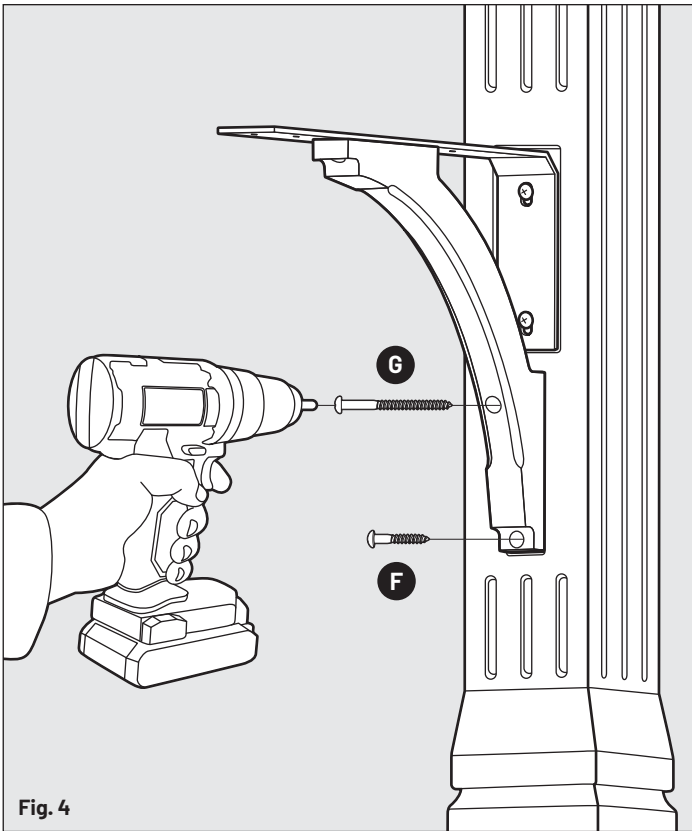

Fig. 4

STEP 4 Attach the Decorative Support Piece to the Upper Post Component using (1) #14 x 3" Pan Head Screw **G** in the upper hole and using (1) #14 x 1-1/2" Pan Head Screw **F** in the lower hole. Both of these screws are included in the kit.

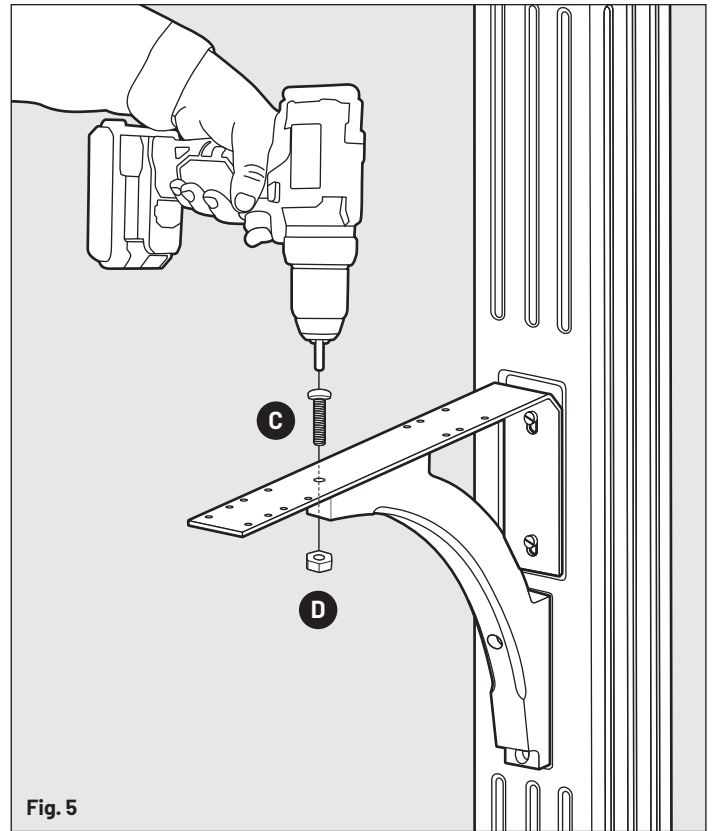

Fig. 5

STEP 5 Connect the Decorative Support Piece to the Steel L Bracket using (1) 1/4" - 20 x 1" Phillips Machine Bolt **C** and (1) 1/4" - 20 Nut **D**. This bolt and nut are included in the kit.

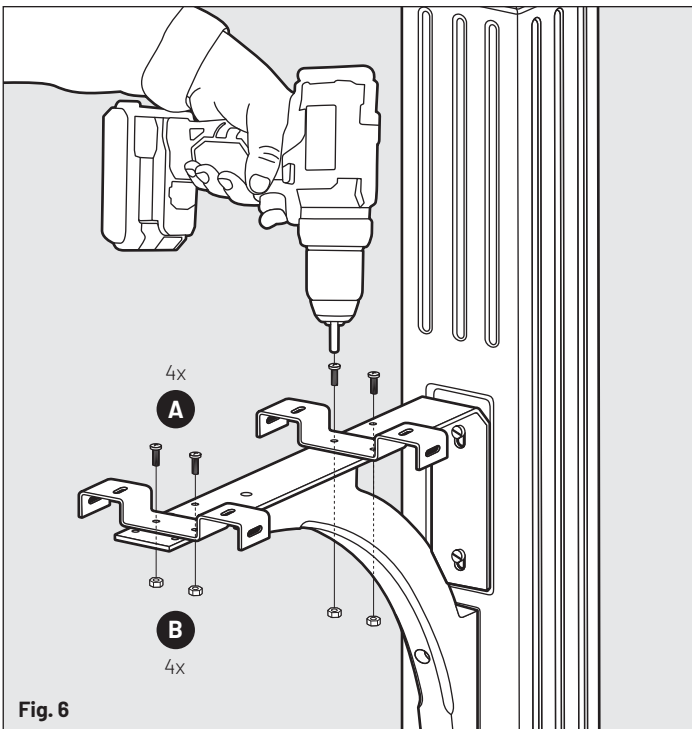

Fig. 6

STEP 6 The Steel L Bracket has numerous hole locations designed to accommodate all standard mailboxes. Locate the holes on the Steel L Bracket that correspond with the mounting holes on your mailbox. Use the (4) #10 - 24 x 1/2" Phillips Machine Bolts **A** and (4) #10 - 24 Nuts **B** to attach the Mounting Brackets to the Steel L Bracket. These bolts and nuts are included in the hardware kit.

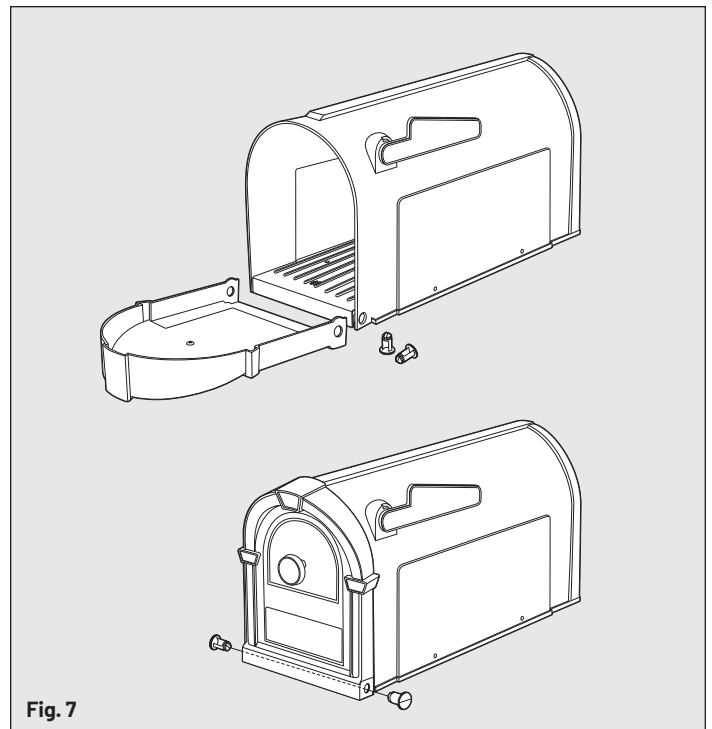
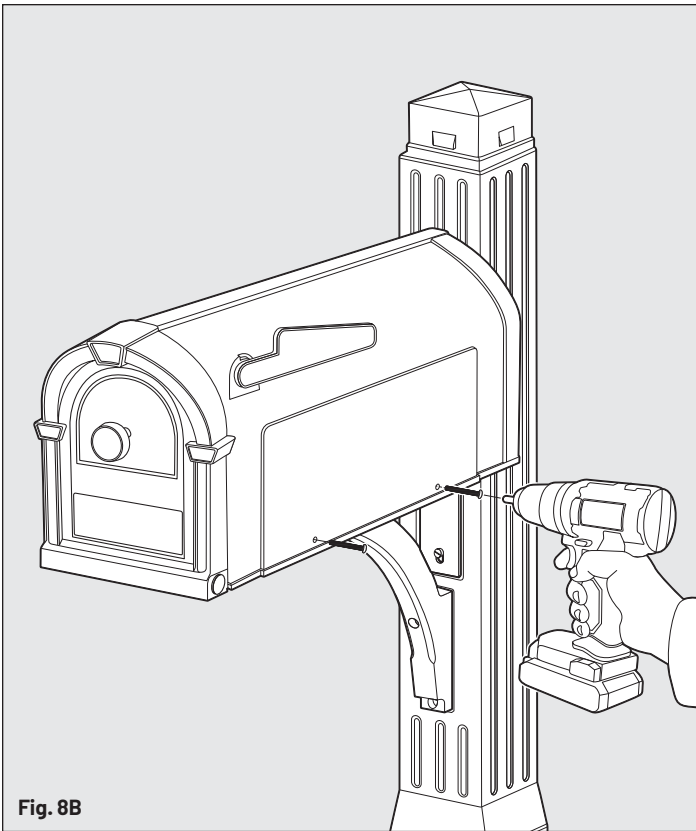
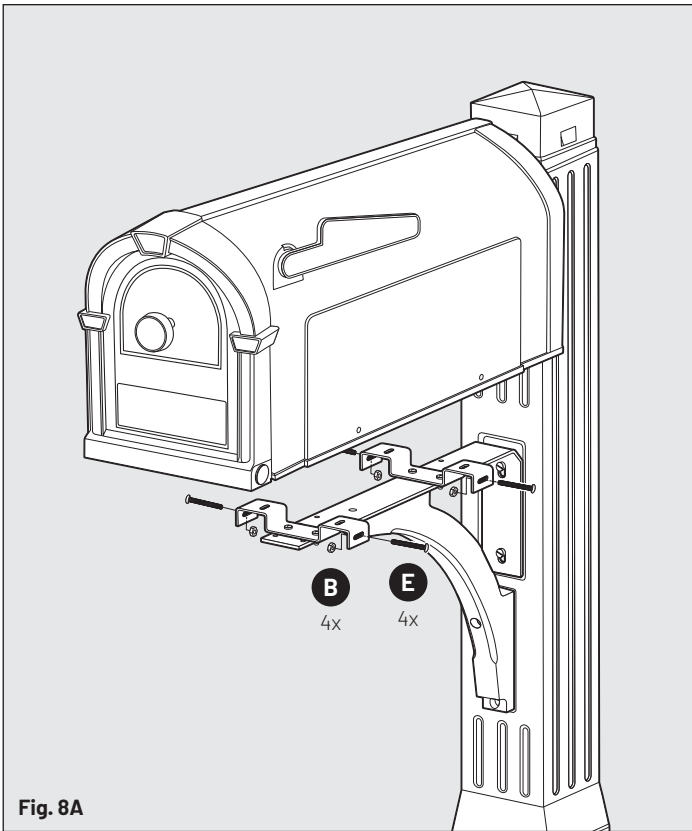
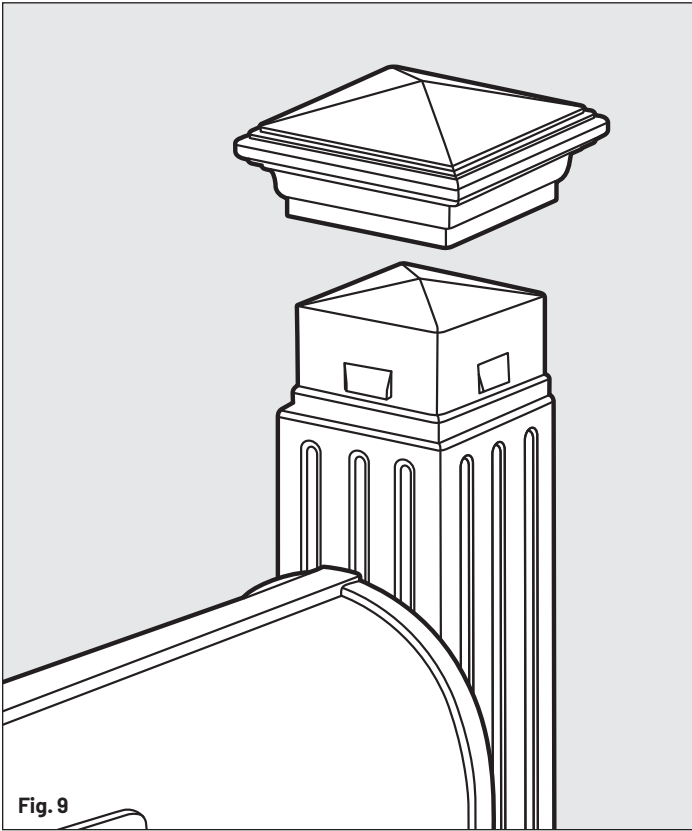

Fig. 7

STEP 7 Assemble your mailbox by using (2) pins to attach Mailbox Door to holes in Mailbox Body. Pins can be snapped into place by pressing firmly with thumb or tapped in using a rubber mallet.
TIP: Make sure the pins are fully snapped into place. If they are installed correctly, you will not be able to remove the pins with your fingers.



STEP 8 Securely attach your mailbox to the Mounting Brackets using the (4) #10 - 24 x 1-1/2" Phillips Machine Bolts **E** and (4) #10 - 24 Nuts **B** (included in the hardware kit).



STEP 9 Attach the Pyramid Finial to the top of the Upper Post Section by pressing and snapping firmly into place.

Postal PRO MAILBOX PRODUCTS 

The Postal Pro is a Creative Solutions, LLC Product
Manufactured in Purvis, MS

Customer Service 877-544-5220
customerservice@creativesolutionscp.com
www.postalpromailboxes.com