

EVERBILT™

Pre-Plumbed 1/2 HP Sewage System

Store SKU #1001600442

Features and Benefits

- Features an 18 in. x 30 in., 30 Gal., heavy duty sewage basin with a water-tight snap-in molded inlet hub
- Ultra strong cover comes with 2 in. threaded discharge and vent flanges, a molded cord grommet, a molded reusable cover seal and eight stainless bolts and washers to secure the cover to the basin
- Automatic, all cast-iron sewage pump passes 2 in. solids and features 10 ft. power and piggy-back float switch cords
- System pumps up to 6,480 GPH
- Ultra quiet, heavy duty ABS compression fit check valve passes a full 2 in. solid
- Molded inlet hub comes with a stainless steel clamp for securing the inlet pipe



Find the perfect pump for your basement with the Everbilt 1/2 HP Pre-Plumbed Sewage Basin System. Perfect for pumping below grade toilets, washing machines and sinks to a sewer or on-site wastewater system.

Arrives pre-plumbed with no internal plumbing needed and ready for installation. The system features an injection-molded structural foam polyethylene basin and cover for exceptional, heavy-duty durability. Includes a tough and solid 1/2 HP cast-iron sewage pump with a strong, tethered mechanical float switch, a pump performance valve and a water-tight molded 4 in. inlet hub.

Basin Dimensions

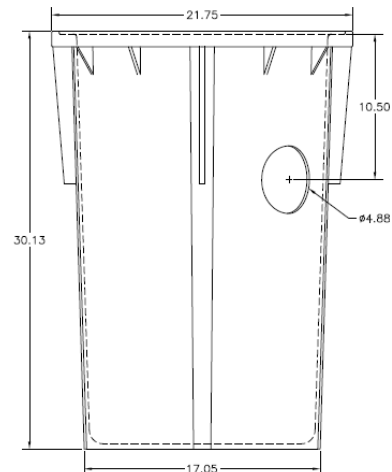

Performance

Performance (Gallons Per Minute)						Float Switch		Solids Handling
TDH	0'	5'	10'	15'	Shut Off	On	Off	
THD1075	108	87	70	40	18'	12.5"	4.5"	2"



Please contact 1-877-297-6069 for further assistance • HOMEDEPOT.com

Pre-Plumbed 1/2 HP Sewage System

Features and Benefits

Basin - 18" x 30"

- 30 U.S. gallon capacity
- Heavy duty structural foam injection molded construction
- Pre-drilled hole at 10-1/2" cL
- Strongest, thickest rim, the 360 degree EZ Grab™ handle - EASIEST TO CARRY!
- Gas, radon, and odor tight
- Heavy duty, non-corrosive glass filled nylon encapsulated inserts

Basin Cover

- 2" slip and 2" threaded vent flanges
- Custom, molded, reusable PVC seal
- Heavy duty structural foam injection molded construction
- 8-bolt, gas, radon and odor tight
- Support 400 lbs. +

Sewage Pump

- 100% tested with its own performance curve
- Rated for continuous duty
- Rugged cast iron construction
- Piggy-back tethered float for automatic or manual operation
- Non-clogging vortex impeller
- Handles 2" solids
- High efficiency permanent split capacitor motor with automatic reset thermal overload protection
- Ball bearings for quiet operation
- Easily replaceable 10 foot power cord for additional lengths
- Mechanically sealed motor for long life

2" Check Valve

- Passes a full 2" solid
- Compression adapters
- Industry's most durable flapper
- Strong, durable ABS body
- Flow arrows clearly marked
- Fits 2" black, galvanized and DWV Schedule 40 pipe

Basin Inlet Hub

- Water and vapor-tight seal
- Fits 4" DWV SCH.40/80
- Built-in "O" rings
- Stainless steel clamp

Components

