



CANOPIA[®]
by PALRAM

HOW TO ASSEMBLE

OLYMPIA™ 10x20 / 3x6.2

IMPORTANT!

Please read these instructions carefully before starting assembly.
Keep these instructions in a safe place for future reference.

www.canopia.com















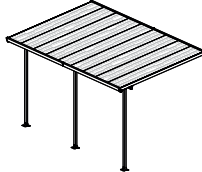

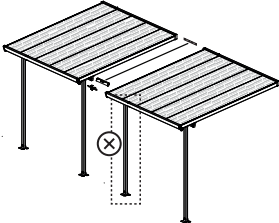

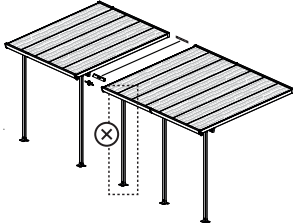

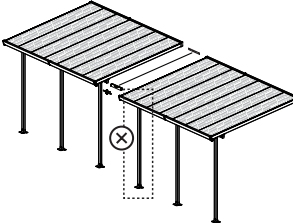





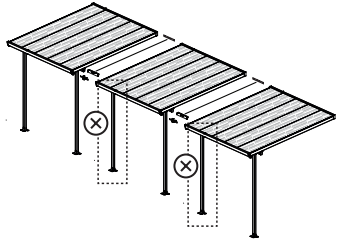

A member of
Palram Industries Ltd.

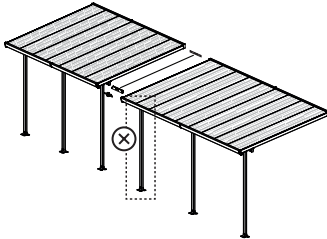



AVAILABLE MODELS

<p>PRIMARY UNIT 10x10 / 3x3</p>	 <p>1 BOX </p>	<p>PRIMARY UNIT 10x14 / 3x4.3</p>	 <p>1 BOX </p>	<p>PRIMARY UNIT 10x18 / 3x5.5</p>	 <p>1 BOX </p>
<p>10x20 / 3x6.2</p>	 <p>2 BOXES </p>	<p>10x24 / 3x7.4</p>	 <p>1 BOX </p>	<p>10x28 / 3x8.6</p>	 <p>2 BOXES </p>
<p>PRIMARY UNIT 10x10 / 3x3</p>	<p>2 BOXES </p>	<p>PRIMARY UNIT 10x10 / 3x3</p>	<p>1 BOX </p>	<p>PRIMARY UNIT 10x14 / 3x4.3</p>	<p>2 BOXES </p>
<p>EZ LINK KIT</p>	<p>1 BOX </p>	<p>PRIMARY UNIT 10x14 / 3x4.3</p>	<p>1 BOX </p>	<p>EZ LINK KIT</p>	<p>1 BOX </p>
<p>10x30 / 3x9.2</p>	 <p>3 BOXES </p>	<p>10x32 / 3x9.8</p>	 <p>1 BOX </p>		
<p>PRIMARY UNIT 10x10 / 3x3</p>	<p>3 BOXES </p>	<p>PRIMARY UNIT 10x14 / 3x4.3</p>	<p>1 BOX </p>	<p>PRIMARY UNIT 10x18 / 3x5.5</p>	
<p>EZ LINK KIT</p>	<p>2 BOXES </p>	<p>EZ LINK KIT</p>	<p>1 BOX </p>		



WE´VE GOT YOU COVERED

NOUS NOUS OCCUPONS DE VOUS | NOS OCUPAMOS DE UD | WIR HELFEN IHNEN GERNE

EN Our self-service form makes it convenient and fast. Go to the URL below or scan the QR code with your phone to submit you request.

FR Notre formulaire en ligne est pratique et rapide. Rendez vous sur l'URL ci-dessous ou scannez le code QR avec votre téléphone pour soumettre votre demande.

ES Nuestro formulario de autoservicio lo hace conveniente y rápido. Vaya al URL de abajo o escanee el código QR con su teléfono para enviar su solicitud.

DE Nutzen Sie schnell und bequem unser Kontaktformular. Rufen Sie die untenstehende URL auf oder scannen Sie den QR-Code mit Ihrem Handy, um Ihre Anfrage zu übermitteln.

Missing a part or need a new one?

Il vous manque une pièce ou vous avez besoin d'une piece supplémentaire?
Me falta una pieza o necesito una nueva?
Fehlt ein Teil oder benötigen Sie ein Ersatzteil?



SCAN ME

canopia.shop/part_request

Need help assembling your product?

Besoin d'aide pour monter votre produit?
Necesito ayuda para montar mi producto?
Benötigen Sie Hilfe bei der Montage Ihres Produkts?



SCAN ME

canopia.shop/support



CUSTOMER SUPPORT



SCAN ME

WE ARE HERE TO HELP

For general questions: canopia.com/contact-us

USA	
	877-627-8476
	generalsupport@poly-tex.com

CANADA	
	905-5646007
	sales@footprintproducts.com

UNITED KINGDOM · IRELAND	
	01302-380775
	customer.serviceUK@palram.com

GERMANY	
	0180-522-8778
	customer.serviceDE@palram.com

FRANCE · BELGIUM	
	+33-169-791-094
	customer.serviceFR@palram.com

ISRAEL	
	04-848-6816
	customer.service@palram.com

ITALY · NETHERLANDS · PORTUGAL · SPAIN	
	+33-169-791-094
	customer.serviceFR@palram.com

AUSTRIA · LUXEMBURG · LIECHTENSTEIN	
	+49-180-522-8778
	customer.serviceDE@palram.com

AUSTRALIA	
	03-9219-4444
	salesvic@palram.com

NORWAY · SWEDEN · ARGENTINA · GREECE · GREENLAND · ICELAND · ESTONIA · JAPAN · LATVIA · LITHUANIA
 MAURITIUS · MEXICO · ROMANIA · RUSSIA · TURKEY · UZBEKISTAN · UKRAINE · SWAZILAND · KOREA

	+972-4-848-6816
	customer.service@palram.com



CUSTOMER SUPPORT



SCAN ME

WE ARE HERE TO HELP

For general questions: canopia.com/contact-us

AUSTRALIA - GREENHOUSES

 03-9544-6-999

 info@mazedistribution.com.au

HUNGARY · SLOVAKIA

 +420-493-523-523

 servis@garland.cz

NEW ZEALAND

 0800 800 880

 customer.service@palram.com

DENMARK

 07-575 42 70

 post@nshnordic.com

SOUTH AFRICA

 011-397-7771

 receptionza@palram.com

CROATIA · SLOVENIA

 0599-37-057

 info@ms-viscom.com

CZECH REPUBLIC

 0493-523-523

 servis@garland.cz

FINLAND

 Neuvonta: 09-6866720
Tuki / Varaosat: 050-3715350

 www.horisontenterprises.fi
tuki@horisontenterprises.fi

POLAND

 Infolinia: 801-011-929
22-349-93-36

 kontakt@ogrodosfera.pl

CYPRUS

 0224-971-13

 alpaco@alpacodomica.com
www.alpacodomica.com

SWITZERLAND

 062-287-33-77

 info@ritter.ch

SITE PREPARATION & FOUNDATION

A - SET A SOLID SURFACE PRIOR TO ASSEMBLY

Concrete / tiled floor & wall

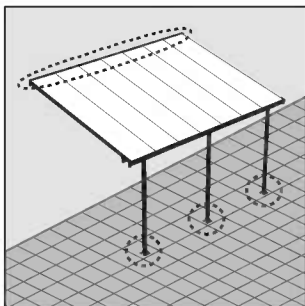

Wooden surface (floor or wall)

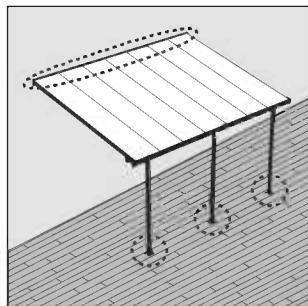

B - USE THE RIGHT SCREWS ON YOUR SURFACE

Concrete / tiled floor & wall

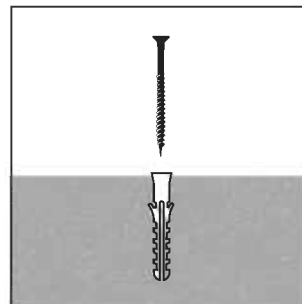

Wooden surface (floor or wall)

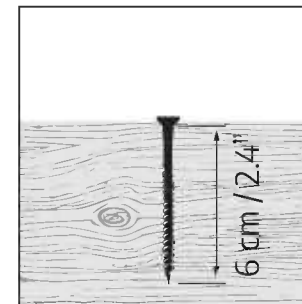

The screws and masonry anchors supplied with the kit are suitable for concrete / tiled floor & wall fixing only.

Please consult with an expert regarding which fasteners are suitable for other surface types (not supplied).

C - FIT YOUR PATIO COVER DIMENSIONS TO THE SITE

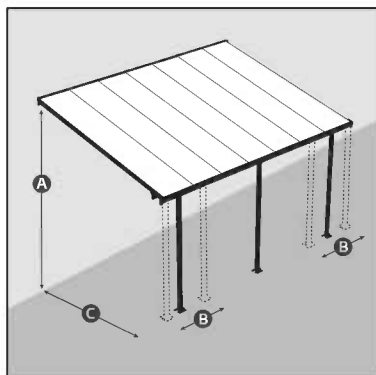

A Wall mounting height

The wall mounting profile (top back) can be adjusted from 260 to 305 cm (102.4" to 120") measuring from the ground to fit your space.

B Pole side positioning

The poles can be adjusted from 5 to 54 cm (2" to 21.3") from the side edges. Adjust poles after assembly and before anchoring.

C Pole to wall depth

Poles distance from the wall can be adjusted from 226 to 286 cm (89" to 112.5") as illustrated in the Diagram.

Decide what height and distance from the wall you would like to mount your patio cover. This will determine the roof angle. Please note that while the product appearance may change slightly as a result of that angle, the snow load weight does not change.

D - CUSTOM THE NUMBER OF POLES REQUIRED

Heavy snow load expected

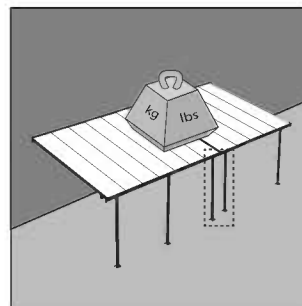

Light or no snow load expected

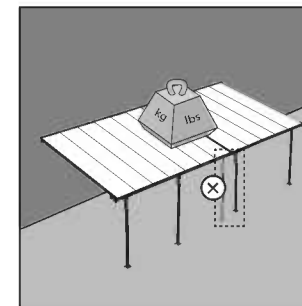

In case of expected heavy snow load, install all supplied poles.

In case of expected light or no snow load, 1 pole at the meeting point of two extensions is sufficient (as shown as on page 2: AVAILABLE MODELS)

IMPORTANT

We recommend checking for restrictions or covenants for building this product in your area. In addition we advise to check if you need to submit any forms or if any permit is required prior to building the product.

SAFETY ADVICE

- It is of utmost importance to assemble all of the parts according to the directions. Do not skip any steps.
- Always wear work gloves during panel sliding.
- Always wear shoes and safety goggles when working with extruded aluminium.
- If using a step ladder or power tools make sure that you follow the manufacturer's safety advice.
- Do not touch overhead power cables with the aluminium profiles.
- Do not climb or stand on the roof.
- Do not attempt to assemble the product in windy or wet conditions.
- Dispose of all plastic bags. Keep them out of reach of small children.
- Keep children away from the assembly area.
- Do not lean against or push the products during construction.
- Do not position your product in an area exposed to excessive winds.
- Do not attempt to assemble this product if you are tired, have taken drugs or alcohol or if you are prone to dizzy spells.
- Make sure there are no hidden pipes or cables in the ground before anchoring to foundation.
- This product is designed to be used mainly as a patio cover.
- Heavy snow load on the roof can make it unsafe to stand below or nearby.
- **The snow must be removed from the structure's roof if the accumulated snow height exceeds 40 cm (1'4").**
- **Make sure to anchor the product directly to a solid foundation to increase the product's stability and wind resistance, especially in areas with severe weather conditions.**

CARE & MAINTENANCE

- When your product needs to be cleaned, use a mild detergent solution and rinse with cold clean water.
- DO NOT use acetone, abrasive cleaners or other special detergents to clean the panels.
- Clean the product once assembly is complete.

TOOLS & EQUIPMENT

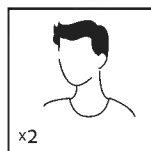

2 people needed

x2



Work gloves

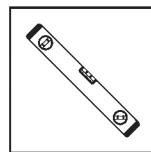

Spirit Level

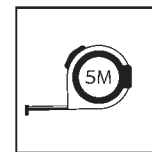

Tape measure

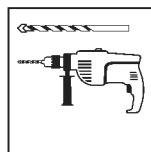

Electric drill -
Drill bit
10 mm | 13/32"



Silicone

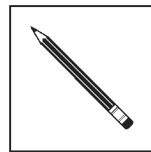

Pencil

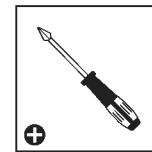

Philips head
Screwdriver



Ladder

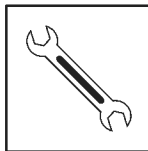

Wrench
10 mm | 13/32"

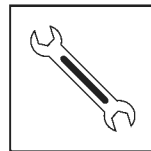

Wrench
13 mm | 1/2"

BEFORE ASSEMBLY

1. Selecting a site:
 - Choose your site carefully before beginning assembly.
 - Choose a sunny position away from overhanging trees.
 - The product must be positioned and fixed on a flat level surface.
2. The product must be secured directly to a solid foundation.
3. This is a multi-part assembly best achieved by two people. Allow at least half a day for the assembly process.
4. Take all components & parts out of the packages. Sort the parts and check against the content parts list.
5. Parts should be laid out close at hand. Keep all small parts (screws etc.) in a bowl so they do not get lost.
6. Please note multi-sided profiles are used in this product. As a result some holes in the profiles are not used during assembly.
7. Please review entire instructions before starting. Carry out the assembly steps in exact order.
8. Please consult your local authorities if any permits are required prior to constructing the product.
9. Having purchased a long patio cover, make sure you received all boxes as shown on page 2 of the instruction manual (AVAILABLE MODELS).
10. Use only the parts registered in the content list, some parts may be surplus.

IMPORTANT!

- Firmly connect the product to a level surface immediately after completion of the assembly.
- Anchoring this product to the wall and ground is essential to its stability and rigidity. It is required to complete this stage in order for the warranty to be valid.
- During assembly use a soft surface below the parts to avoid scratches and damages.

DURING ASSEMBLY

- During assembly, you will encounter different icons for different products. Please see below for more information:



- During assembly you will encounter the information icon, please refer to the relevant assembly step for additional comments and assistance.



- You may use silicone lubricant spray on the frame in order to help you slide the panels into the profiles. Do not spray the panels.



- Use a rubber mallet if necessary.

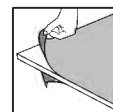

- Make sure you remove covering plastic film from both sides of the panel.

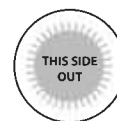

- All panels with the stamped words "THIS SIDE OUT" must be facing out to create full UV protection. Remove plastic sticker as panels are locked in place.



- Steps marked with dashed outlines refer to Extensions only.
- Some of the steps are irrelevant for an assembly of a single product.
- When assembling a single or an extended product, some parts may be surplus.

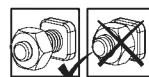

- These 2 icons below indicate if screw's tightening is required or not.
- Temporary tightening of a few screws may be needed to prevent a profile from sliding out.



- Tighten all screws once assembly is completed.



IMPORTANT ASSEMBLY STEPS

When encountering this information icon during assembly, please refer to the relevant assembly step for important additional comments.

- Step 5:** It is important to plan the installation area, mark as per the instructions and level the surface prior to the assembly. Make sure you use suitable screws and anchors.
The wall-mounting profile can be adjusted from 260 to 305cm (102.4" to 120") above ground.
The adjusting is done when measuring and drilling.
- Step 7:** Please apply silicone sealants above beam **#7288**, in order to prevent water from seeping in.
- Step 9:** Make sure that the angle between the back wall profile and the panel supporting profiles is 90 degrees.
- Steps 11-12:** Please note you install the panels with the UV protected side out (marked with "THIS SIDE OUT"). Remove plastic sticker as panels are locked in place.
*For dark panels only: Make sure you remove covering plastic film from both sides of the panel.

- Step 14:** **a** - Apply silicone sealants on the inner part of **#7997**, and connect to the profile as depicted in **drawing a**.
c - Do not tighten screw **#4043** yet, in order to allow the final adjustments done in **step 16**.
- Step 16:** **a+c** - Please adjust the poles (inside out and sideways) by sliding them to their final position prior to anchoring. Make sure that the poles distance from the Patio cover side edge does not exceed 54 cm/21.3".
b - Adjust the gutter head's angle according to your needs and tighten screws **#4043**.
- Step 18:** Anchoring this product to the ground is essential to its stability and rigidity.
It is required to complete this stage in order for your warranty to be valid.

PRÉPARATION DU TERRAIN ET FONDATIONS

A - PRÉVOIR UNE SURFACE SOLIDE AVANT LE MONTAGE

Suelo y pared de baldosas /
hormigón

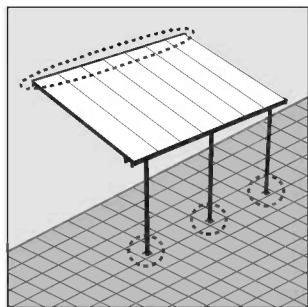

Superficie de madera
(piso o pared)

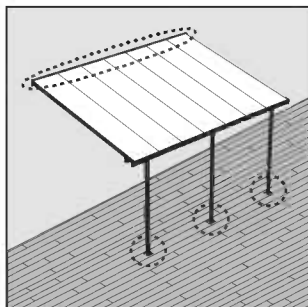

B - UTILISER DES VIS ADAPTÉES À CHAQUE SURFACE

Suelo y pared de baldosas /
hormigón

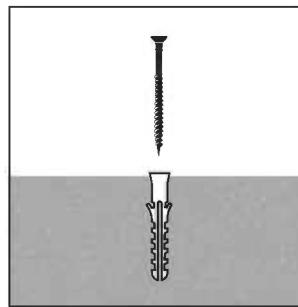

Superficie de madera
(piso o pared)

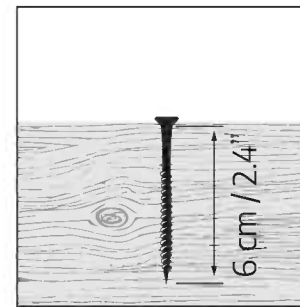

Les vis et chevilles fournies avec le kit ne conviennent que pour la fixation de sols et murs en carrelage / béton.

Demandez à un expert quels éléments de fixation conviennent à un autre type de surface (non inclus).

C - ADAPTEZ LES DIMENSIONS DE VOTRE PERGOLA À SON EMPLACEMENT

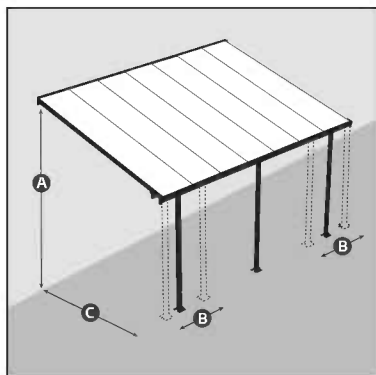

A Hauteur de montage mural

Le profilé pour le montage mural (en haut à l'arrière) peut être adapté à votre espace de 260 à 305 cm (102,4" à 120") mesurés à partir du sol.

B Positionnement latéral des poteaux

Les poteaux peuvent être réglés de 5 à 54 cm (2" à 21,3") à partir des bords latéraux. Réglez les poteaux après le montage et avant l'ancrage.

C Distance entre les poteaux et le mur

La distance entre les poteaux et le mur peut être réglée de 226 à 286 cm (89" à 112,5"), comme indiqué sur le schéma.

Décidez à quelle hauteur et à quelle distance du mur vous souhaitez monter votre abri de terrasse. Cela permet de déterminer l'angle de la couverture. Notez que si cet angle peut légèrement modifier l'aspect du produit, le poids de la charge de neige ne change pas.

D - LE NOMBRE DE POTEAUX NÉCESSAIRES EST PERSONNALISABLE

Si une forte charge de neige est attendue

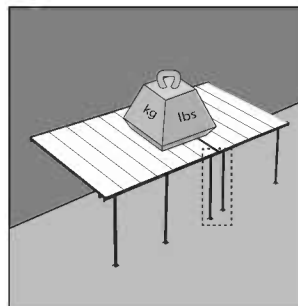

Si une charge de neige faible ou nulle est attendue

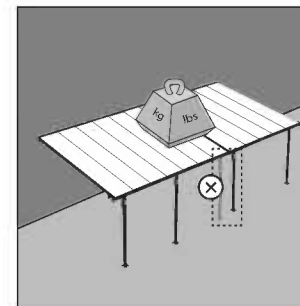

Si une forte charge de neige est attendue, installez tous les poteaux fournis.

Si une charge de neige faible ou nulle est attendue, 1 poteau au point de rencontre de deux rallonges est suffisant (comme illustré à la page 2 : MODÈLES DISPONIBLES (AVAILABLE MODELS)).

— IMPORTANTE —

Avant d'assembler ce produit dans votre région, nous vous recommandons de vous renseigner sur les restrictions ou réglementations locales. Nous vous conseillons en outre de vérifier si vous devez soumettre des formulaires ou si un permis est requis avant de monter le produit.

CONSEILS DE SECURITE

- Très important ! Veuillez suivre scrupuleusement les instructions de ce manuel et réaliser les étapes dans l'ordre énoncé.
- Nous recommandons vivement le port de gants de protection pendant le montage.
- Portez toujours des chaussures de travail et des lunettes de protection lorsque vous travaillez des pièces en aluminium extrudé.
- Lors de l'utilisation d'une échelle ou d'outils électriques, assurez-vous de bien suivre les consignes de sécurité du fabricant.
- Veillez à ne pas toucher de câbles aériens avec les profilés en aluminium.
- Ne montez pas sur le toit.
- N'essayez pas de monter la produit s'il y a du vent ou s'il fait humide.
- Jetez tous les sacs en plastique en appliquant les règles de sécurité et maintenez-les hors de portée des jeunes enfants.
- Eloignez les enfants de la zone d'assemblage.
- Ne vous appuyez pas contre la produit et ne la poussez pas pendant le montage.
- Ne positionnez pas la produit dans un endroit trop exposé au vent.
- N'essayez pas de monter la produit si vous êtes fatigué, si vous êtes sous l'effet de drogues, de médicaments ou d'alcool ou encore si vous êtes sujet aux vertiges.
- Assurez-vous qu'il n'y a pas de tuyaux ou de câbles cachés dans le sol avant d'ancrer à la fondation.
- Ce produit a été conçu pour être principalement utilisé comme Couvertures de patio.
- Une lourde charge de neige sur le toit peut rendre dangereux le fait de se tenir debout en dessous ou à proximité
- **La neige doit être enlevée du toit de la structure de la hauteur de neige accumulée dépasse 40 cm (1'4").**
- **Assurez-vous d'ancrer le produit directement sur une surface solide pour augmenter sa stabilité et sa résistance au vent, en particulier dans les zones soumises à des conditions météorologiques extrêmes.**

ENTRETIEN & MAINTENANCE

- Pour nettoyer votre produit, utilisez une solution détergente douce et rincez à l'eau claire et froide.
- **NE PAS** utiliser d'acétone ni de produits nettoyants ou autres détergents spéciaux pour nettoyer les panneaux clairs.
- Nettoyez le produit une fois le montage termine.

OUTILS ET ÉQUIPEMENT

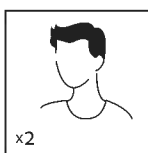

Nécessite 2 personnes

x2

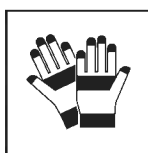

Gants de travail

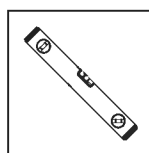

Niveau

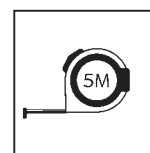

Mètre

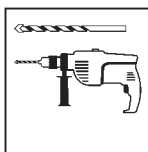

Perceuse filaire avec foret 10 mm | 13/32"



Silicone



Crayon



Tournevis cruciforme



Echelle

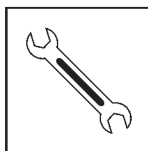

Clé 10 mm | 13/32"

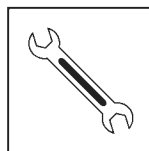

Clé 13 mm | 1/2"

AVANT L'ASSEMBLAGE

- Choisir un endroit :
 - Choisissez votre site avec soin avant de commencer l'assemblage.
 - Choisissez un endroit ensoleillé loin des arbres en saillie.
 - La produit doit être positionnée et fixée sur une surface plane.
- Le produit doit être fixé directement sur une surface solide
- Il s'agit d'un assemblage multi parties qu'il vaut mieux réaliser à deux.
Comptez au moins une demi journée pour le processus de montage.
- Retirez tous les composants des paquets. Triez les éléments et vérifiez la liste.
- Les éléments doivent se trouver à portée de main. Gardez tous les petits éléments (vis etc.) dans un bol pour ne pas les perdre.
- Veillez noter que des coupes multi faces sont utilisées dans cette produit.
C'est pourquoi certains trous dans les coupes ne sont pas utilisés pendant le montage.
- Veillez vérifier toutes les instructions avant de commencer.
Procédez aux étapes de montage dans l'ordre exact.
- Veillez consulter les autorités locales au cas où des permis sont nécessaires pour la construction du produit.
- Si vous avez acheté une Pergola Feria longue, assurez-vous d'avoir reçu toutes les boîtes comme indiqué à la page 2 du manuel d'instructions
MODÈLES DISPONIBLES (AVAILABLE MODELS).
- Utilisez uniquement les pièces enregistrées dans la liste de contenu, certaines pièces peuvent être excédentaires.

IMPORTANT!

- Fixez fermement le produit sur une surface plane immédiatement après la fin de l'assemblage.
- L'ancrage de ce produit au mur et au sol est essentiel pour sa stabilité et sa rigidité.
Cette étape doit être complétée pour que la garantie soit valable.
- Pendant le montage, placez une surface souple sous les pièces pour éviter de les érafler ou de les endommager.

DURANT L'ASSEMBLAGE

- Lors du montage, vous trouverez différentes icônes correspondant à différents produits.
Pour de plus amples informations, veuillez vous référer à ce qui suit:



- Pendant le montage, vous verrez l'icône d'information, veuillez-vous référer à la phase de montage correspondante pour des commentaires et une assistance supplémentaires.



- Vous pouvez utiliser un spray de lubrifiant pour silicone afin de vous aider à glisser les panneaux dans les profilés. Ne pulvérisez pas les panneaux.



- Utilisez un maillet en caoutchouc si nécessaire.

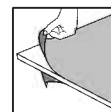

- Assurez-vous de retirer le film plastique couvrant des deux côtés du panneau.

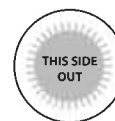

- Tous les panneaux estampillés "THIS SIDE OUT" doivent être orientés vers l'extérieur pour assurer une protection UV intégrale. Retirez les stickers en plastique quand les panneaux sont verrouillés et bien en place.



- Les étapes marquées en pointillés ne concernent que les extensions.
- Certaines étapes ne sont pas nécessaires pour l'assemblage d'un produit unique.
- Lors de l'assemblage d'un produit unique ou d'une extension, il peut rester des pièces.

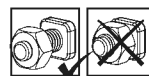

- Ces 2 icônes indiquent s'il est nécessaire de serrer les écrous ou non.
- Il peut être nécessaire de serrer temporairement certaines vis pour empêcher un profilé de se déplacer.



- Serrez toutes les vis une fois l'assemblage terminé.



PRINCIPALES ÉTAPES D'ASSEMBLAGE

Lorsque vous rencontrez cette icône d'information pendant l'assemblage, veuillez vous référer à l'étape d'assemblage correspondante pour d'autres commentaires importants.

Étape 5:

Avant de commencer l'assemblage, il est important de bien préparer la zone d'installation, de marquer et de niveler la surface en respectant les instructions du mode d'emploi. Assurez-vous d'utiliser les bonnes vis et pattes de scellement.

Le profilé de raccordement de paroi (supérieur-arrière) est ajustable de 260 à 305 cm (102,4 à 120 po.) au-dessus du sol. Cet ajustement s'effectue au moment de la prise de mesures et du perçage.

Étape 7:

Veuillez appliquer un enduit en silicone sur les poutres n°7288 afin de prévenir toute infiltration d'eau.

Étape 9:

Assurez-vous que l'angle entre la paroi arrière du mur et le panneau de support des parois soit de 90 degrés.

Étapes 11-12:

Veuillez vous assurer d'avoir installé les panneaux avec le côté anti-UV vers l'extérieur (indiqué par l'inscription "THIS SIDE OUT") Retirez les stickers en plastique alors que les panneaux sont verrouillés en place.

*Pour les panneaux sombres uniquement : Assurez-vous de retirer le film plastique couvrant des deux côtés du panneau.

Étape 14:

a - Appliquez les joints en silicone sur la face interne de n°7797 et raccordez-le à la paroi, comme vous le voyez sur l'illustration **a**.

c - Ne serrez pas encore la vis n° 4043, car cela nous empêcherait d'effectuer les derniers ajustements décrits à l'étape 16.

Étape 16:

a+c - Veuillez ajuster les poteaux (intérieur et latéralement) en les faisant glisser vers leur position finale avant de les fixer. Assurez-vous que la distance entre le côté de l'abri de la terrasse et les poteaux soit inférieure à "54 cm / 21,3".

b - Ajustez l'angle de la bouche de la gouttière en fonction de vos besoins, puis serrez la vis n° 4043.

Étape 18:

Cette étape d'ancrage du produit au sol est essentielle à sa stabilité et à sa rigidité, elle est de plus nécessaire pour assurer la validité de votre garantie.

STANDORTWAHL & FUNDAMENT

A - VOR DEM ZUSAMMENBAU EINEN FESTEN UNTERGRUND VERLEGEN

Beton / Fliesenfußboden
und Fliesenwand

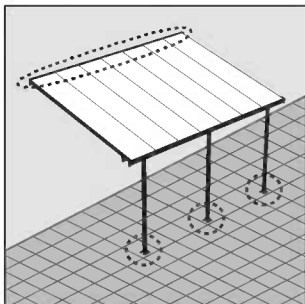

Starke Holzgundfläche
(Boden oder Wand)

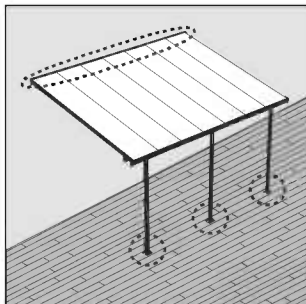

B - VERWENDEN SIE DIE RICHTIGEN SCHRAUBEN FÜR IHREN UNTERGRUND

Beton / Fliesenfußboden
und Fliesenwand

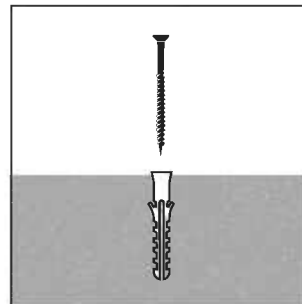

Starke Holzgundfläche
(Boden oder Wand)

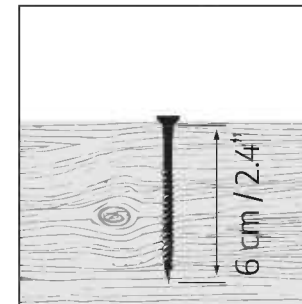

Die mit dem Bausatz
gelieferten Schrauben und
Maueranker sind nur für
die Befestigung auf Beton/
Fliesenböden und an
Fliesenwänden geeignet.

Bitte fragen Sie einen Experten,
welche Befestigungsmittel für
andere Untergründe geeignet
sind (nicht im Lieferumfang
enthalten).

C - PASSEN SIE DIE FLEXIBLEN KOMPONENTEN IHRES TERRASSENDACHS AN DEN JEWEILIGEN STANDORT AN

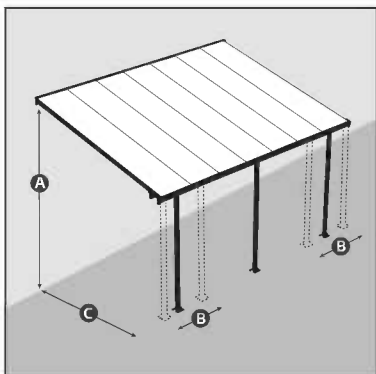

Entscheiden Sie, in welcher Höhe und
in welchem Abstand zur Wand Sie
Ihre Terrassenüberdachung montieren
möchten. Dies bestimmt den Winkel des
Daches. Bitte beachten Sie, dass sich das
Aussehen des Produkts durch diesen
Winkel zwar leicht verändern kann,
das Gewicht der Schneelast sich jedoch
nicht ändert.

A Höhe der Wandbefestigung

Das Profil für die Wandmontage (obere Rückseite)
kann von 260 bis 305 cm, vom Boden aus gemessen,
an Ihren Standort angepasst werden.

B Seitliche Positionierung der Pfosten

Die Pfosten können mit einem Abstand von 5 bis 54 cm
von den Seitenkanten aus eingestellt werden. Justieren
Sie die Pfosten nach der Montage, jedoch vor der
Verankerung.

C Tiefe des Pfostens zur Wand

Der Abstand der Pfosten von der wann kann zwischen
226 und 286 cm gewählt werden (siehe Abbildung).

D - ES KANN EINE INDIVIDUELLE ANZAHL VON PFOSTEN BENÖTIGT WERDEN

Es wird eine hohe Schneelast
erwartet

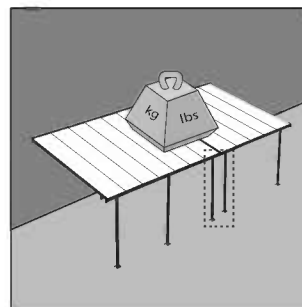

Es wird nur eine leichte,
oder keine Schneelast erwartet

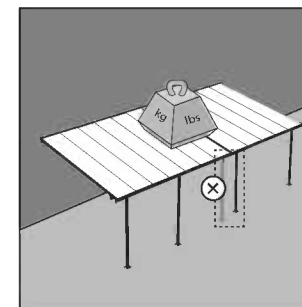

Sofern eine hohe Schneelast zu erwarten ist, müssen alle mitgelieferten Pfosten montiert werden.
Wenn keine oder nur eine geringe Schneelast zu erwarten ist, reicht 1 Pfosten am Treffpunkt von zwei
Verlängerungsteilen aus. (wie auf Seite 2 abgebildet: VERFÜGBARE MODELLE (AVAILABLE MODELS))

WICHTIG

Bevor Sie mit der Montage beginnen, vergewissern Sie sich bitte beim zuständigen Bauamt,
ob es in Ihrer Region Einschränkungen oder Auflagen für den Bau des gewählten Produktes gibt.
Wir bitten Sie außerdem zu prüfen, ob eine Genehmigung für den Bau erforderlich ist.

SICHERHEITSHINWEISE

- Es ist sehr wichtig, dass alle Teile gemäß den Anweisungen in dieser Anleitung zusammengebaut werden. Lassen Sie bitte keinen Schritt aus.
- Tragen Sie bei der Montage unbedingt Arbeitshandschuhe. Wir empfehlen Ihnen außerdem dringend, festes Schuhwerk und eine Schutzbrille zu tragen.
- Achten Sie beim verwenden einer Leiter oder Elektrowerkzeug bitte auf die jeweiligen Sicherheitshinweise des Herstellers.
- Berühren Sie mit den Aluminiumprofilen keine Oberleitungen.
- Halten Sie Kinder vom Aufbaubereich fern.
- Die Montage darf nur bei trockenem und windstillem Wetter erfolgen.
- Nicht auf das Dach klettern oder darauf stehen.
- Entsorgen Sie alle Plastikbeutel sicher und bewahren sie außerhalb der Reichweite von Kleinkindern auf.
- Während des Aufbaus sollten Sie sich nicht gegen das Produkt lehnen oder Druck ausüben.
- Suchen Sie einen windgeschützten Standort für das Produkt aus.
- Versuchen Sie nicht, dieses Produkt zu montieren, wenn Sie müde sind, Drogen oder Alkohol zu sich genommen haben oder zu Schwindelanfällen neigen.
- Bevor Sie das Produkt im Fundament verankern, vergewissern Sie sich, dass sich dort keine versteckten Rohre oder Kabel befinden.
- Dieses Produkt ist hauptsächlich für die Verwendung als Terrassenüberdachungen vorgesehen.
- Eine hohe Schneelast auf dem Dach kann den Aufenthalt unter oder in der Nähe des Daches unsicher machen.
- **Der Schnee muss von den Dachstrukturen entfernt werden, wenn die angesammelte Schneehöhe 40 cm (1'4") überschreitet.**
- **Um die Stabilität und Windbeständigkeit des Produkts zu erhöhen, müssen Sie es direkt auf einem soliden Fundament verankern, insbesondere in solchen Gegenden, in denen die Witterungsbedingungen streng sind.**

PFLEGE & WARTUNG

- Zur Reinigung verwenden Sie ein mildes Reinigungsmittel und spülen es mit kaltem, sauberem Wasser nach.
- Verwenden Sie zur Reinigung der Paneele KEIN Aceton und auch keine scheuernden Reinigungsmittel oder Spezialreiniger.
- Säubern Sie das Produkt nach dem Aufbau.

WERKZEUGE & AUSRÜSTUNG

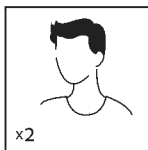

- Zwei Personen erforderlich

x2

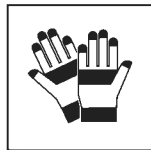

- Arbeitshandschuhe

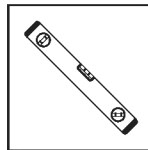

- Wasserwaage

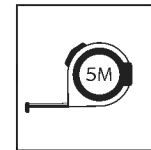

- Maßband

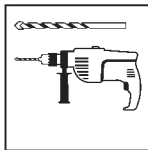

- Bohrmaschine mit Bohrer 10 mm | 13/32"



- Silikon



- Stift

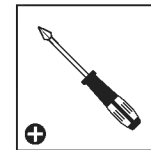

- Kreuzschlitzschraubendreher



- Leiter

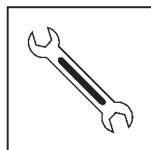

- Schraubenschlüssel 10 mm | 13/32"

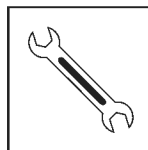

- Schraubenschlüssel 13 mm | 1/2"

VOR DEM ZUSAMMENBAU

- Die Standortwahl:
 - Wählen Sie Ihren Standort sorgfältig, bevor Sie mit dem Aufbau beginnen.
 - Das Produkt muss auf einem flachen Untergrund aufgestellt und befestigt werden.
 - Wählen Sie eine Position abseits von überhängenden Bäumen.
- Das Produkt muss direkt auf einem festen Untergrund befestigt werden.
- Für die Montage dieses Produktes sind zwei Personen erforderlich. Sie sich für den Zusammenbau mindestens einen halben Tag Zeit.
- Packen Sie die Bauteile aus und überprüfen Sie, ob alle Teile der Liste aufgeführt sind.
- Die Teile sollten griffbereit ausgelegt werden. Bewahren Sie alle kleinen Teile (Schrauben usw.) in einer Schüssel auf, damit nichts verloren geht.
- Beachten Sie bitte, dass bei diesem Produkt mehrseitige Profile verwendet werden. Während des Zusammenbaus sind daher nicht alle Löcher in den Profilen relevant.
- Lesen Sie vor Beginn des Aufbaus die gesamte Anleitung durch. Führen Sie die Montageschritte in genauer Reihenfolge durch.
- Fragen Sie bei den örtlichen Behörden nach, ob es irgendwelche Einschränkungen für den Aufbau gibt oder Genehmigungen erforderlich sind.
- Wenn Sie die lange Terrassenüberdachung gekauft haben, vergewissern Sie sich, dass Sie alle Verpackungseinheiten erhalten haben, so, wie sie auch auf Seite 2 der Gebrauchsanweisung aufgeführt sind VERFÜGBARE MODELLE (AVAILABLE MODELS).
- Verwenden Sie nur die in der Inhaltsliste angeführten Teile, es können eventuell überschüssige Teile finden.

WICHTIG!

- Nach Beendigung des Aufbaus muss das Produkt sofort auf einer ebenen Fläche fest verankert werden.
- Die Verankerung dieses Produkts sowohl an der Wand als auch auf dem Boden ist für seine Stabilität und Festigkeit unerlässlich. Dieser Schritt ist auch wegen der Gültigkeit der Garantie erforderlich.
- Legen Sie während des Aufbaus eine weiche Unterlage unter die einzelnen Teile, um Kratzer und Schäden zu vermeiden.

WÄHREND DER MONTAGE

- Während der Montage werden Sie verschiedene Symbole für unterschiedliche Produkte sehen. Weitere Informationen finden Sie unten:



- Während der Montage begegnet Ihnen das Informationssymbol, weitere Hinweise und Hilfestellungen finden Sie auf der Seite "WICHTIGE MONTAGESCHRITTE".



- Sie können Silikonschmierspray auf den Rahmen sprühen, um das Einschoben der Platten in die Profile zu erleichtern. Besprühen Sie nicht die Platten.



- Nehmen Sie – falls nötig – einen Gummihammer zur Hilfe.

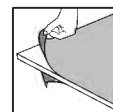

- Entfernen Sie, falls vorhanden, die Schutzfolie von beiden Seiten.

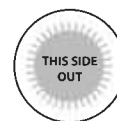

- Alle mit den Worten "THIS SIDE OUT" versehenen Platten müssen nach außen zeigen, um den vollen UV-Schutz zu gewährleisten. Entfernen Sie die Aufkleber, sobald die Platten montiert sind.



- Die mit Strichlinien markierten Schritte beziehen sich nur auf Erweiterungen.
- Einige der Schritte sind für den Zusammenbau eines einzelnen Produkts nicht relevant.
- Beim Zusammenbau eines einzelnen oder eines erweiterten Produkts können einige Teile überflüssig sein.

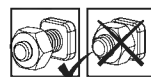

- Diese 2 Symbole unten zeigen an, ob das Anziehen der Schrauben erforderlich ist oder nicht.



- Das vorübergehende Anziehen einiger Schrauben kann erforderlich sein, um ein Herausrutschen des Profils zu verhindern.
- Ziehen Sie nach Abschluss der Montage alle Schrauben fest.



WICHTIGE MONTAGESCHRITTE

Wenn Sie bei der Montage auf dieses Informationssymbol stoßen, finden Sie im jeweiligen Montageschritt wichtige Zusatzhinweise.

- Schritt 5:** Es ist wichtig, den Installationsbereich zu planen, nach den Anweisungen zu markieren und die Oberfläche vor der Montage zu ebnen. Achten Sie darauf, dass Sie geeignete Schrauben und Dübel verwenden.
Das Wandmontage-Profil (oben-hinten) kann von 260cm bis 305cm (102,4“ bis 120“) über den Boden angepasst werden. Das Anpassen ist abgeschlossen, wenn gemessen und gebohrt wurde.
- Schritt 7:** Bitte tragen Sie Silikondichtstoff über Balken **Nr. 7288** auf, um das Eindringen von Wasser zu verhindern.
- Schritt 9:** Achten Sie darauf, dass der Winkel zwischen dem Rückwand-Profil und den Trage-Profilen 90 Grad beträgt.
- Schritte 11-12:** Bitte achten Sie darauf, die Paneele mit der UV-geschützten Seite nachaußen (Kennzeichnung «THIS SIDE OUT») Entfernen Sie die Aufkleber, sobald die Platten montiert sind.
*Nur für dunkle Panels: Entfernen Sie, falls vorhanden, die Schutzfolie von beiden Seiten.

- Schritt 14:** **a** - Bitte bringen Sie die Silikondichtungen auf dem Innenteil von **Nr. 7997** an und verbinden Sie es mit dem Profil wie in Zeichnung **a** dargestellt.
c - Bitte ziehen Sie noch nicht die Schraube **Nr. 4043** fest, um die letzten Anpassungen in **Schritt 16** zu ermöglichen.
- Schritt 16:** **a+c** - Bitte passen Sie die Pfosten an (von innen nach außen und zur Seite), indem Sie sie vor der Verankerung in ihre endgültige Position schieben. Achten Sie darauf, dass der Abstand der Pfosten zur Terrassen-Abdeckung “54 cm / 21,3” nicht überschreitet.
b - Bitte passen Sie den Kopfstückwinkel der Dachrinne bedarfsgerecht an und ziehen Sie die Schrauben **Nr. 4043** fest.
- Schritt 18:** Die Verankerung dieses Produkts im Untergrund ist wesentlich für seine Stabilität und Festigkeit. Sie ist unablässlich, um diesen Arbeitsschritt zu beenden, damit Ihre Garantie gültig bleibt.

PREPARACIÓN DEL SITIO Y CIMENTACIÓN

A - PREPARE UNA SUPERFICIE DE SUELO SÓLIDO ANTES DEL MONTAJE

Suelo y pared de baldosas / hormigón

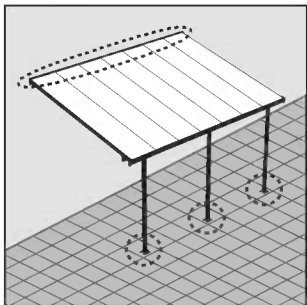

Superficie de madera (piso o pared)

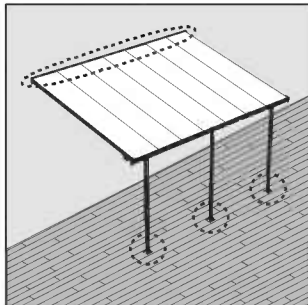

B - UTILICE LOS TORNILLOS APROPIADOS PARA CADA SUPERFICIE

Suelo y pared de baldosas / hormigón

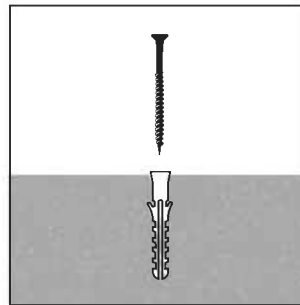

Superficie de madera (piso o pared)

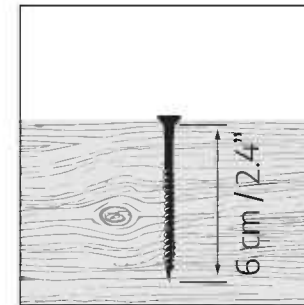

Los tornillos y anclajes de pared suministrados con el kit sólo son adecuados para la fijación de suelos y paredes de baldosas/ hormigón.

Pregunte a un experto qué elementos de fijación son adecuados para otro tipo superficie (no incluidos).

C - ADAPTE LAS DIMENSIONES DE PERGOLA AL LUGAR

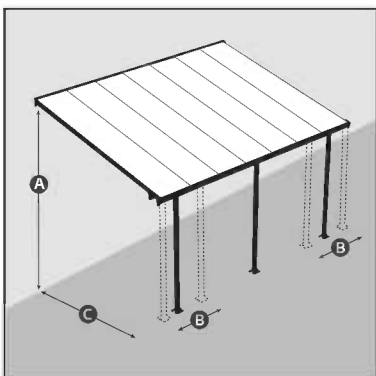

A Altura de montaje en la pared

El perfil de montaje en la pared (parte superior trasera) se puede ajustar de 260 a 305 cm (102,4" a 120") medidos desde el suelo y así adaptarse a su espacio.

B Posicionamiento lateral de los postes

Los postes pueden ajustarse de 5 a 54 cm (2" a 21,3") desde los bordes laterales. Ajuste los postes después del montaje y antes del anclaje.

C Distancia de los postes a la pared

La distancia de los postes a la pared puede ajustarse de 226 a 286 cm (89" a 112,5") como se ilustra en el diagrama.

Decida a qué altura y distancia de la pared desea montar su pergola. Esto determinará el ángulo de la pergola. Tenga en cuenta que aunque el aspecto del producto puede cambiar ligeramente como resultado de ese ángulo, el peso de la carga de nieve no cambia.

D - EL NÚMERO DE POSTES NECESARIOS ES PERSONALIZABLE

Si se espera una carga de nieve pesada

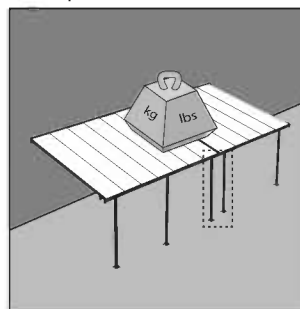

Si se espera una carga de nieve ligera o nula

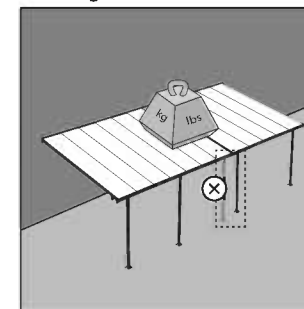

Si se espera una gran carga de nieve pesada, instale todos los postes suministrados.

Si se espera una carga de nieve ligera o nula, es suficiente con 1 poste en el punto de encuentro de dos extensiones. (Como se muestra en la página 2: MODELOS DISPONIBLES (AVAILABLE MODELS)).

IMPORTANTE

Recomendamos comprobar las restricciones o convenios para la construcción de este producto en su área. Además, aconsejamos comprobar si necesita presentar algún formulario o si se requiere algún permiso antes de construir el producto.

CONSEJOS DE SEGURIDAD

- Es de suma importancia montar todas las partes de acuerdo con las instrucciones. No se salte ningún paso.
- Recomendamos firmemente el uso de guantes de trabajo durante el montaje.
- Use siempre zapatos y gafas de seguridad al trabajar con aluminio extruido.
- Al usar una escalera plegable o herramientas eléctricas asegúrese de que sigue las instrucciones de seguridad de los fabricantes.
- No toque los cables eléctricos aéreos con los perfiles de aluminio.
- No trepe ni se ponga de pie en el tejado.
- No intente montar el invernadero en días de viento o días con humedad.
- Disponga todas las bolsas plásticas en lugar seguro - guárdelas fuera del alcance de niños.
- Mantenga a los niños fuera del área de montaje.
- No se apoye ni empuje el producto durante la construcción.
- No coloque su producto en un área expuesta al viento excesivo.
- No intente montar este producto si usted está cansado, ha tomado drogas o alcohol o si usted es propenso a ataques de mareo.
- Asegúrese de que no hay tuberías o cables ocultos en el suelo antes de anclar a los cimientos.
- Este producto fue diseñado para ser utilizado principalmente como un pegola.
- No es seguro pararse debajo o cerca cuando hay gran cantidad de nieve sobre el techo.
- **La nieve debe eliminarse del techo de la estructura si la altura de nieve acumulada excede los 40 cm (1'4").**
- **Asegúrese de anclar el producto directamente a una base sólida para aumentar su estabilidad y resistencia al viento, especialmente en áreas con condiciones climáticas severas.**

CUIDADOS & MANTENIMIENTO

- Cuando precise limpiar su producto, use una solución de detergente suave y aclare con agua limpia fría.
- NO use acetona, limpiadores abrasivos u otros detergentes especiales para limpiar los paneles transparentes.
- Limpie el producto una vez terminado el montaje.

HERRAMIENTAS Y EQUIPOS

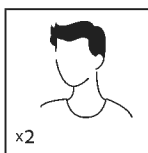

- Se necesitan dos personas

x2



- Guantes de trabajo

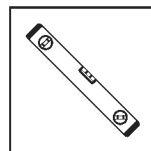

- Regla de nivel

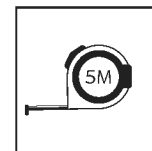

- Cinta métrica

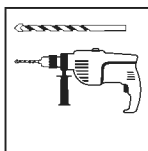

- Taladro eléctrico con broca o mecha 10 mm | 13/32"



- Silicona



- Lápiz

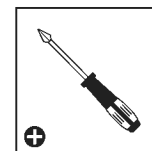

- Destornillador de cabeza Philips



- Escalera



- Llave 10 mm | 13/32"

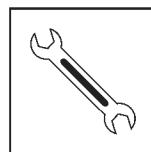

- Llave 13 mm | 1/2"

ANTES DEL MONTAJE

1. Seleccionar un lugar:
 - Elija su sitio cuidadosamente antes del ensamblaje inicial.
 - El producto debe colocarse y fijarse en una superficie plana y nivelada.
 - Escoja una ubicación soleada y apartada de árboles que la cubran.
2. El producto debe fijarse directamente a una superficie sólida.
3. Este montaje consta de varias partes y sería óptimo que lo realizaran dos personas. El proceso de montaje llevará alrededor de medio día.
4. Extraiga todas las piezas de componentes de sus embalajes. Ordene las piezas y compruebe que están todas usando la lista de contenidos.
5. Las piezas deberían colocarse cerca y tenerlas a mano. Ponga las piezas pequeñas (p. ej. tornillos) en un bol para no perderlas.
6. Por favor, tenga en cuenta que este producto incluye perfiles con múltiples superficies. Como resultado, algunos de los agujeros de los perfiles no se utilizan durante el montaje.
7. Por favor, revise todas las instrucciones antes de empezar. Siga los pasos del montaje en el orden exacto.
8. Consulte las limitaciones, requisitos, permisos y a las autoridades locales para la construcción de este cobertizo de jardín.
9. Si ha comprado una cubierta de patio larga, asegúrese de haber recibido todas las cajas como se muestra en Página 2 del manual de instrucciones MODELOS DISPONIBLES (AVAILABLE MODELS).
10. Use solo las partes registradas en la lista de contenido, algunas piezas pueden sobrar.

IMPORTANTE!

- Fije con firmeza el producto a una superficie nivelada inmediatamente después de completar el montaje.
- Anclar este producto a la pared y al suelo es esencial para su estabilidad y rigidez. Es necesario completar esta etapa para que la garantía sea válida.
- Durante el montaje, ponga algo suave por debajo de las piezas, para evitar que se rayen o estropeen.

DURANTE EL MONTAJE

- Durante el montaje, se encontrará con diferentes iconos. Para obtener más información, consulte lo siguiente:



- Cuando encuentre el ícono de información, por favor lea con cuidado dicho paso con comentarios y asistencia adicionales.



- Puede utilizar spray lubricante de silicona para facilitar el deslizamiento de los paneles en los contornos. No ponga spray en los paneles.

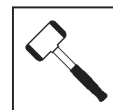

- Use un martillo de goma si hiciera falta.

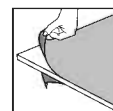

- Asegúrese de quitar la película plástica que cubre ambos lados del panel.



- Todos los paneles que tengan estampado LADO EXTERIOR (THIS SIDE OUT) deben mirar hacia fuera para ofrecer una protección UV completa. Quite la pegatina de plástico una vez los paneles se enganchen en su sitio.



- Los pasos marcados con líneas discontinuas se refieren únicamente a las extensiones.
- Algunos de los pasos son innecesarios para el montaje de un solo producto.
- Durante el montaje de un producto individual o de una extensión, pueden sobrar algunas piezas.

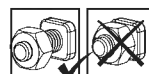

- Los siguientes 2 íconos le indicarán si el ajuste de los tornillos es necesario o no.



- en algún paso puede ser necesario apretar de forma temporal algunos tornillos para evitar que se caiga un perfil.
- Apriete todos los tornillos una vez esté completado el montaje



PASOS DE MONTAJE IMPORTANTES

Al encontrar este icono de información durante el montaje, consulte el paso de montaje correspondiente para obtener importantes comentarios adicionales.

Paso 5: Es importante planificar el área de instalación, marcarla según las instrucciones y nivelar la superficie antes del montaje. El perfil de montaje en la pared (parte superior trasera) se puede ajustar de 260 a 305 cm (102,4" a 120") por encima del suelo. El ajuste se hace al medir y taladrar.

Paso 7: Por favor, aplique selladores de silicona encima de la viga **n. 7288** para evitar que el agua se cuele en su interior.

Paso 9: Asegúrese de que el ángulo entre el perfil del muro posterior y el panel que soporta los perfiles es de 90 grados.

Pasos 11-12: Asegúrese de que instala los paneles con la cara que protege de los rayos UV hacia afuera (marcado con "THIS SIDE OUT") Quite la pegatina de plástico una vez los paneles se enganchen en su sitio.
*Solo para paneles oscuros: Asegúrese de quitar la película plástica que cubre ambos lados del panel.

Paso 14: **a** - Por favor, aplique selladores de silicona en la parte interior de **n. 7997**, y conéctelo al perfil como se muestra en el **dibujo a**.











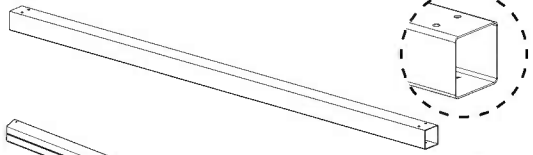
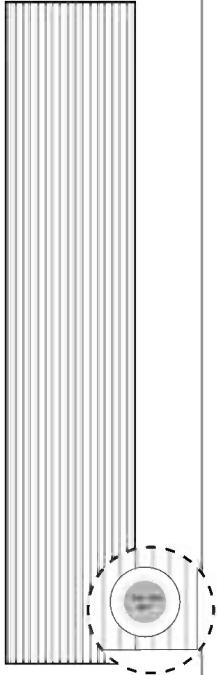
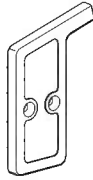

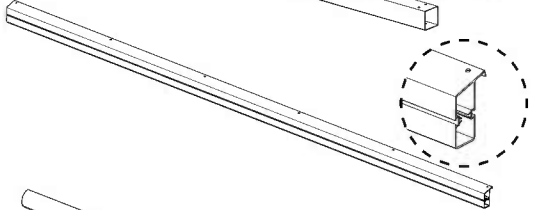
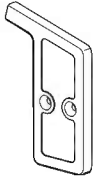

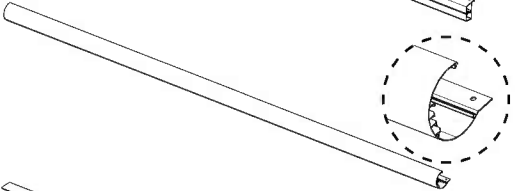

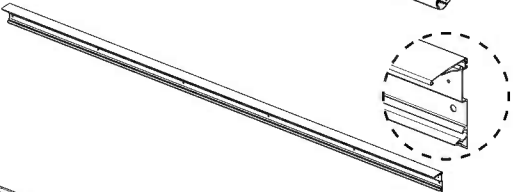
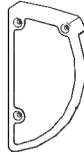
c - Por favor, no apriete el tornillo **n. 4043** todavía para permitir los ajustes finales que se hacen en el **paso 16**.

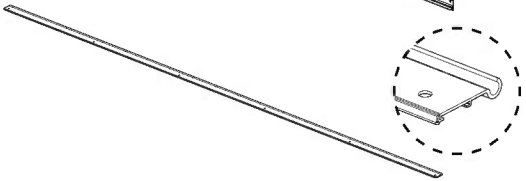
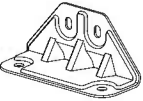
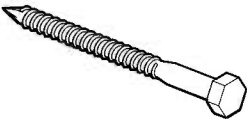
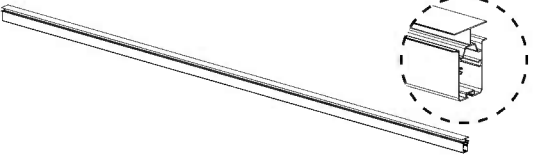
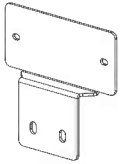
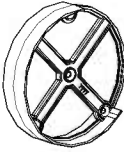
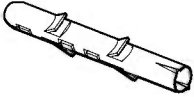
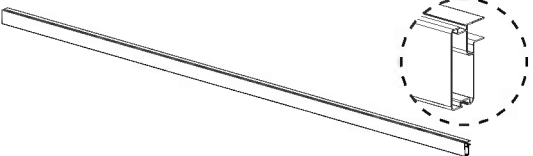
Paso 16: **a+c** - Por favor, ajuste los postes (al revés y de lado) deslizándolos a su posición final antes de anclarlos. Asegúrese de que la distancia de los postes desde el borde lateral de la pergola no supere los "54 cm / 21,3".

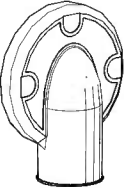
b - ajuste el ángulo de la cabeza de la canaleta según sus necesidades y apriete los tornillos **n. 4043**.

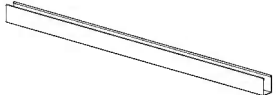
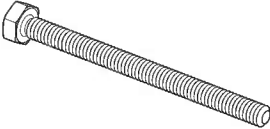
Paso 18: Anclar este producto al suelo es esencial para su estabilidad y rigidez. Es necesario completar esta fase para que su garantía sea válida.

Contents

Item		Qty.	Item		Qty.	Item		Qty.	Item		Qty.
8618		2	9119		5	7296		1	8192		26 (+3)
1041		1				7297		1	466		26 (+4)
8078		1				7294		1	450		8
7288		1				7295		1	4043		18 (+2)
7291		1	8758		4				4000		14 (+1)
8619		4	8621		4	7997		2	4010		14 (+1)
8620		2	7038		4	7998		2	433		30 (+2)
8803		10							424		8
									7121		8
									5000		24 (+6)
									5001		26 (+4)

1

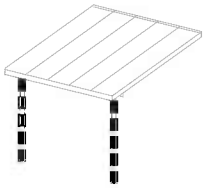

8618.....
 8578.....
 424.....
 7121.....
 433.....

.....2
4
4
4
8

8618
 8758
 8758
 8618
 8758
 8758
 433
 424
 7121
 433
 8758
 8758
 433
 424

x2

2

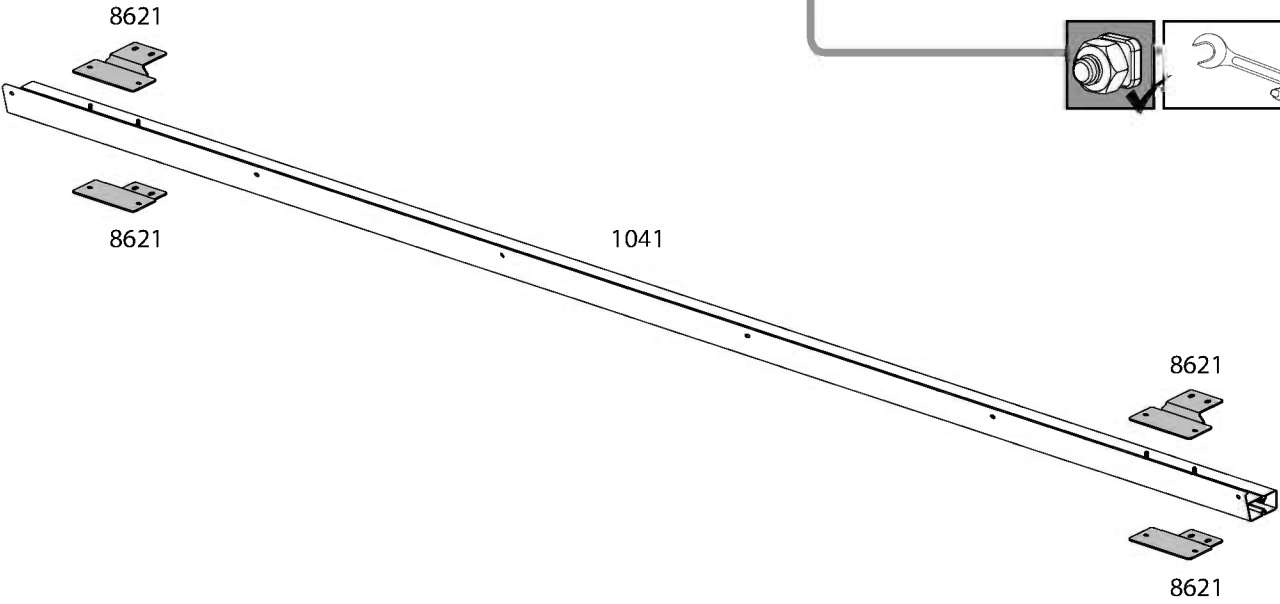
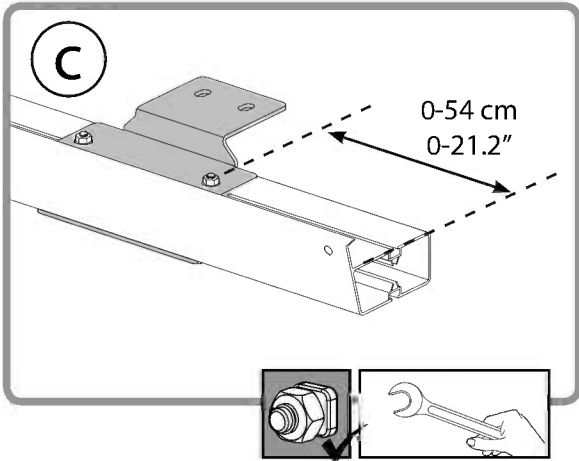
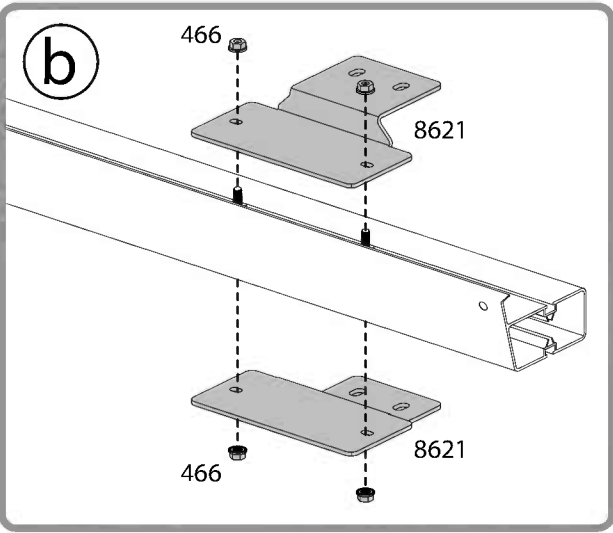
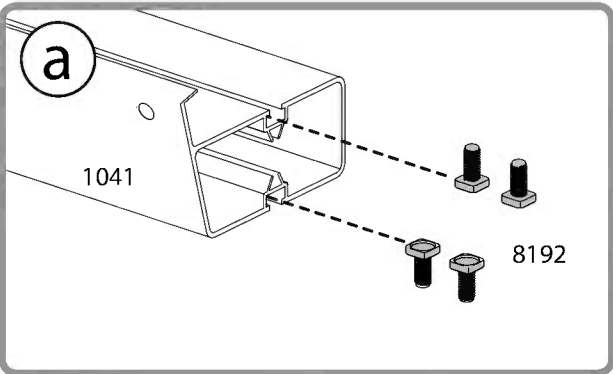
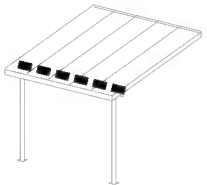

3

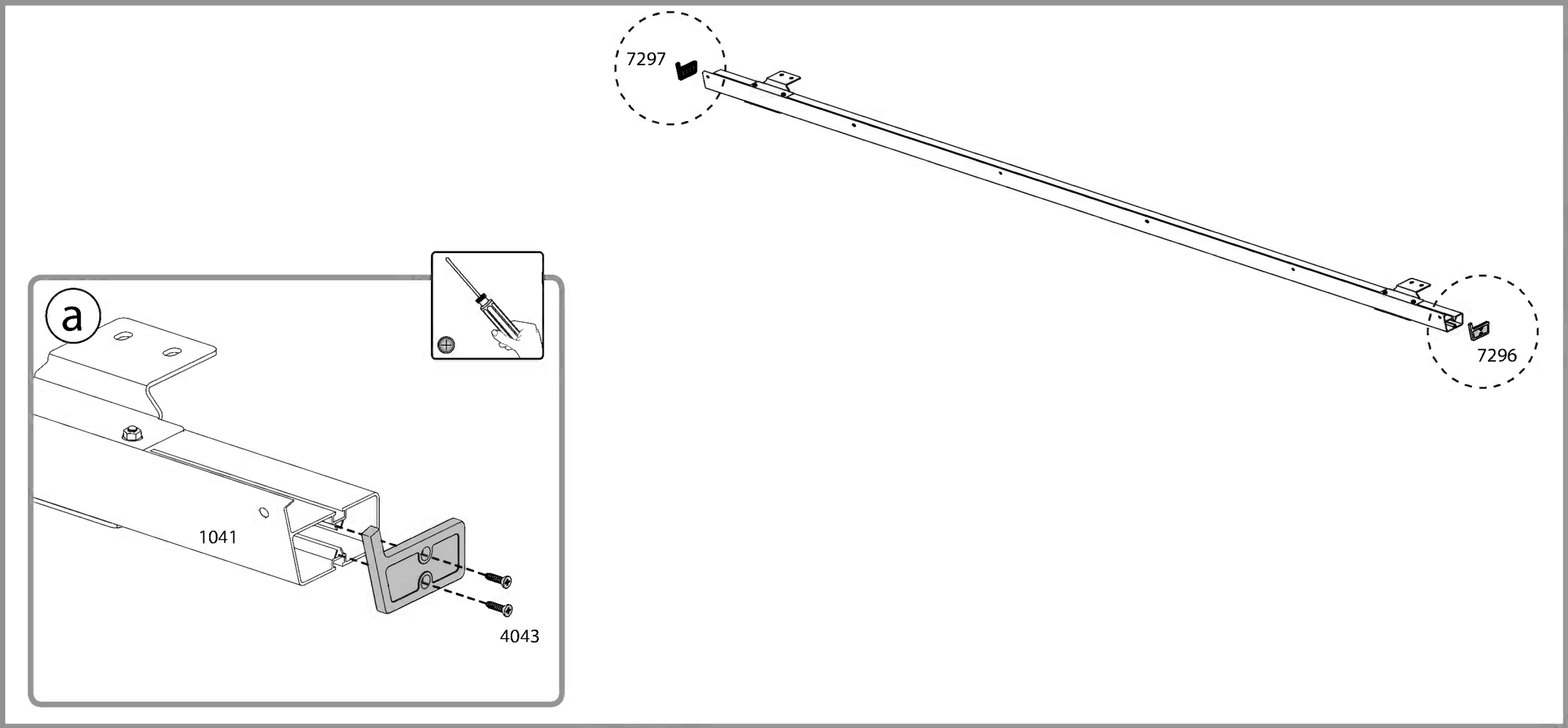
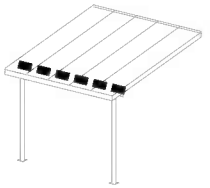

4

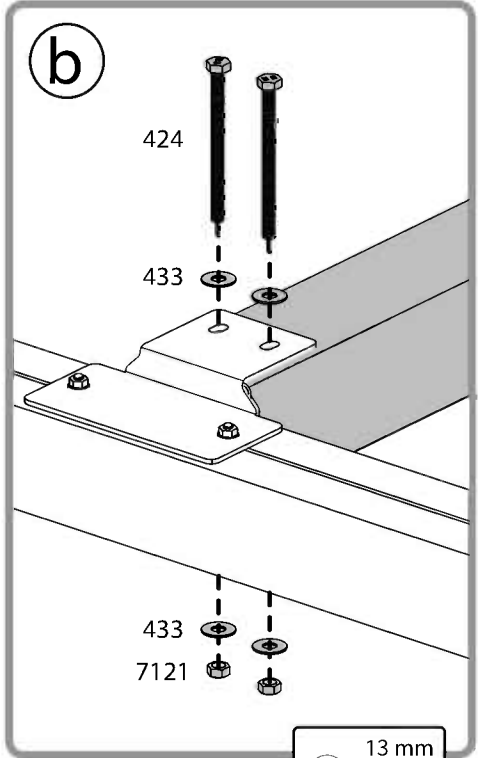
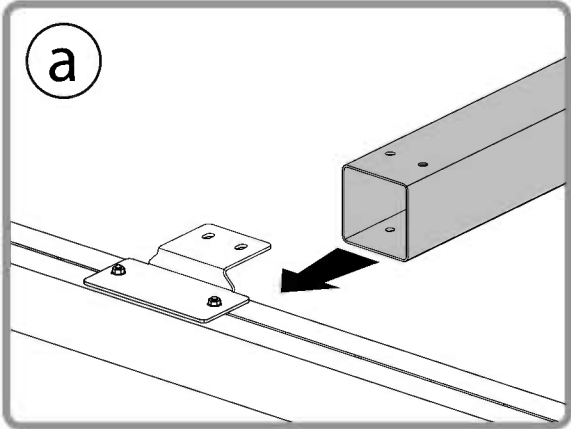
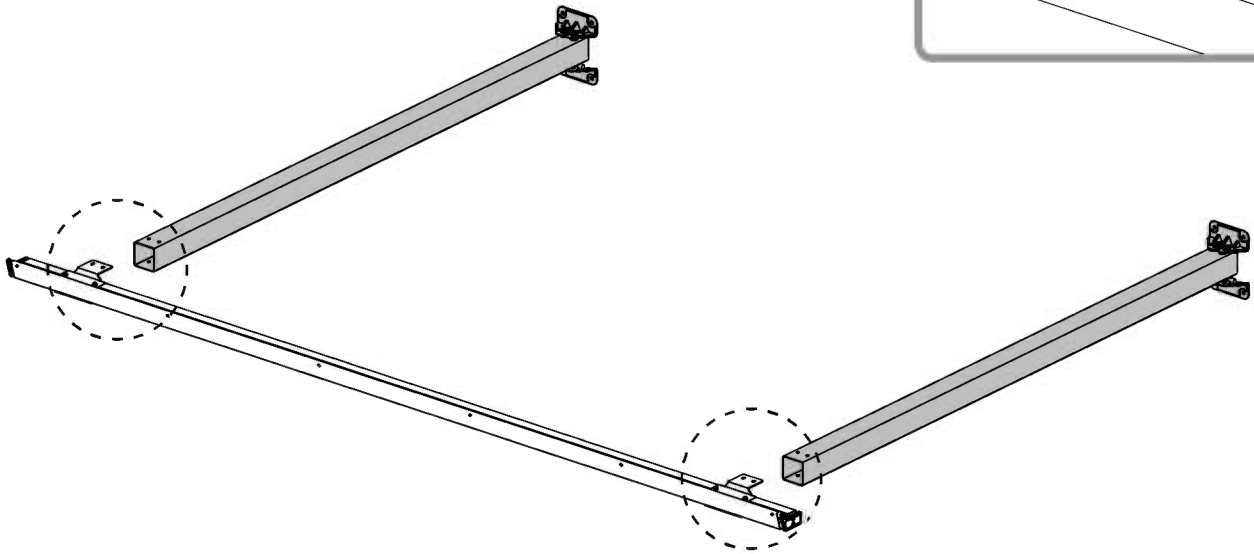
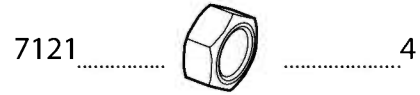
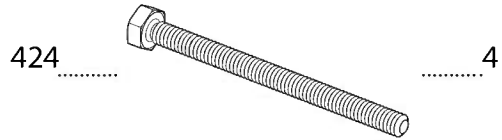
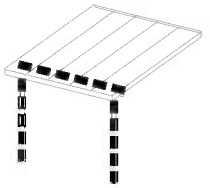

5 *i*

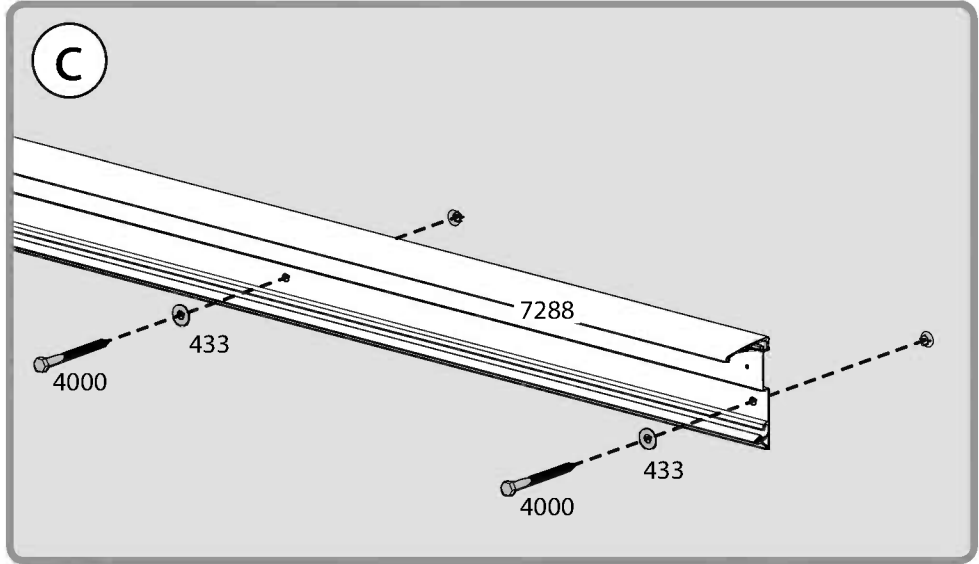
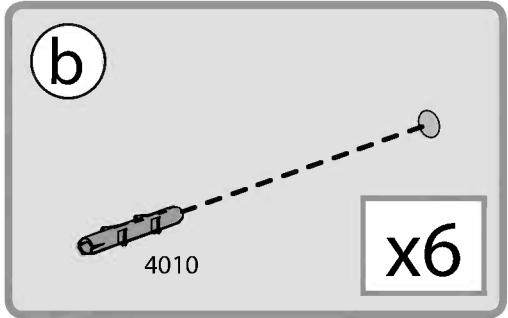
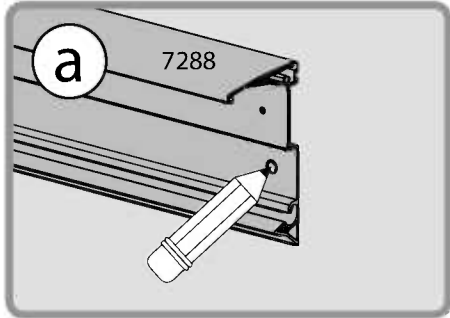
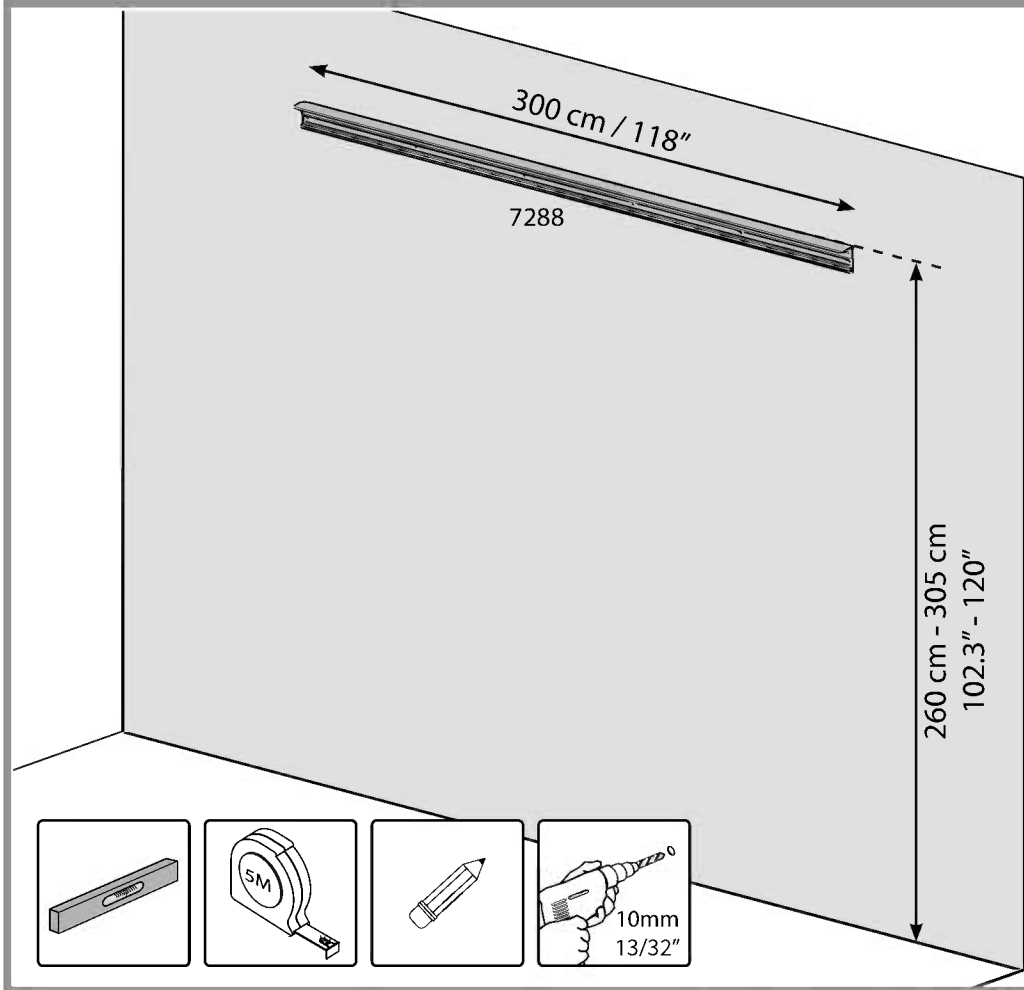
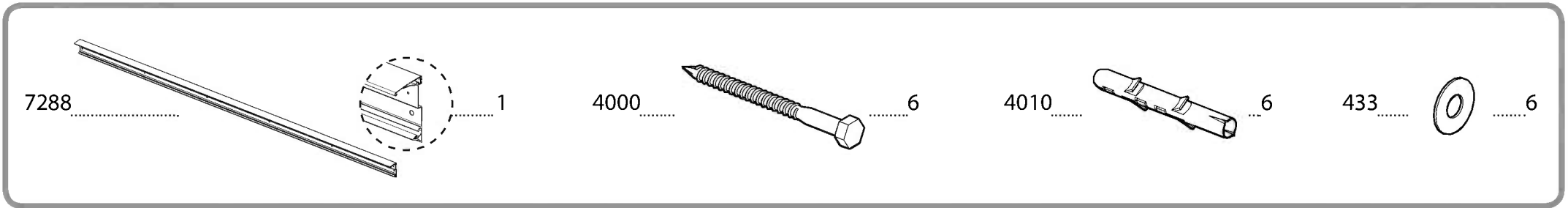

6

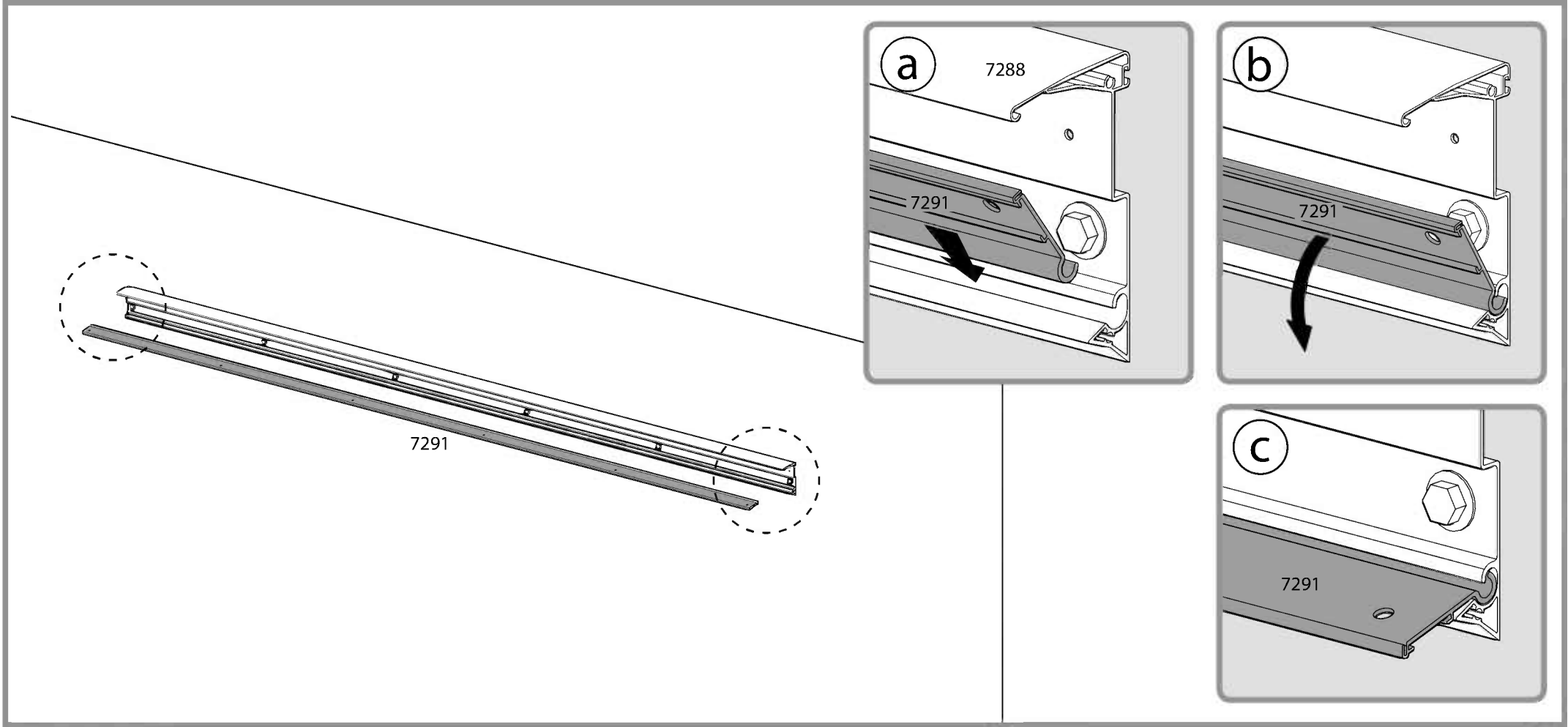
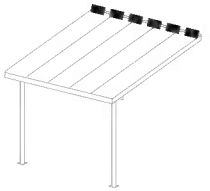

7 **i**

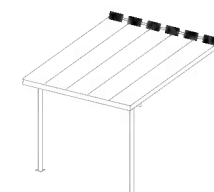

8192 6



466 6



7294 1

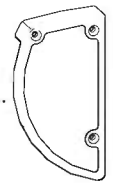

7295 1

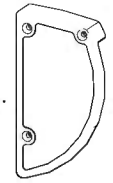

4043 6

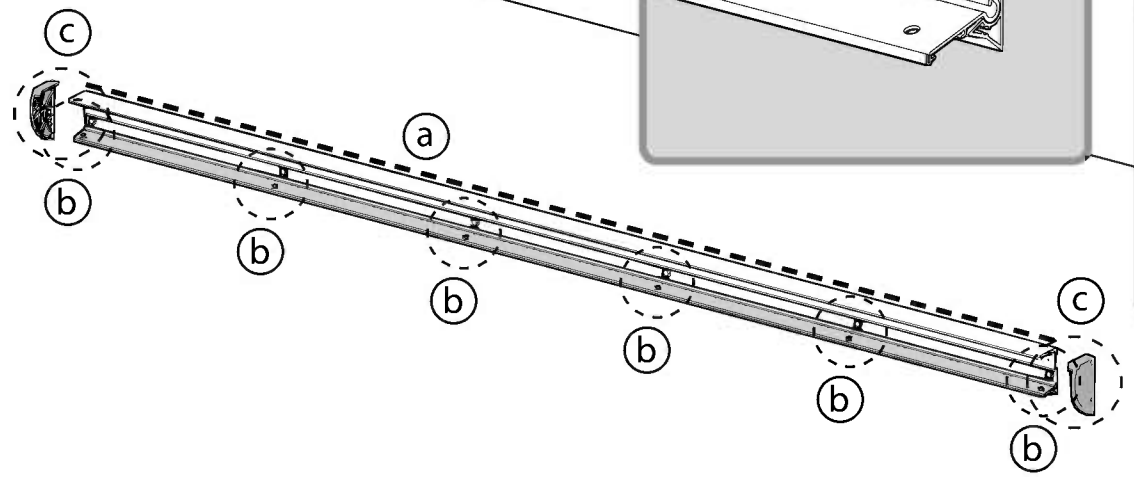
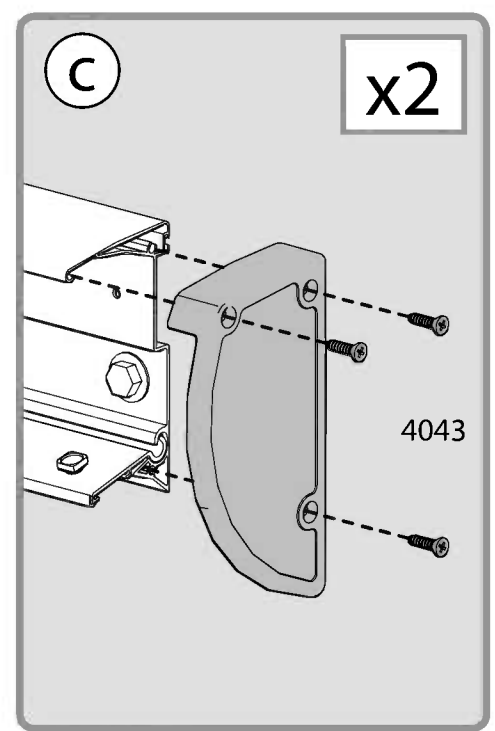
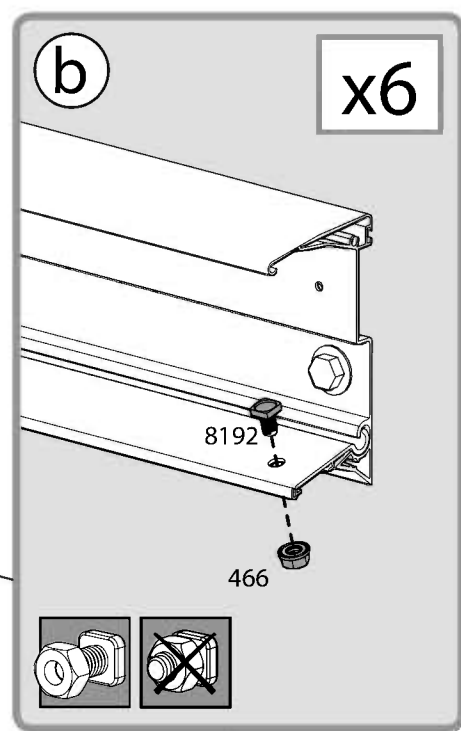
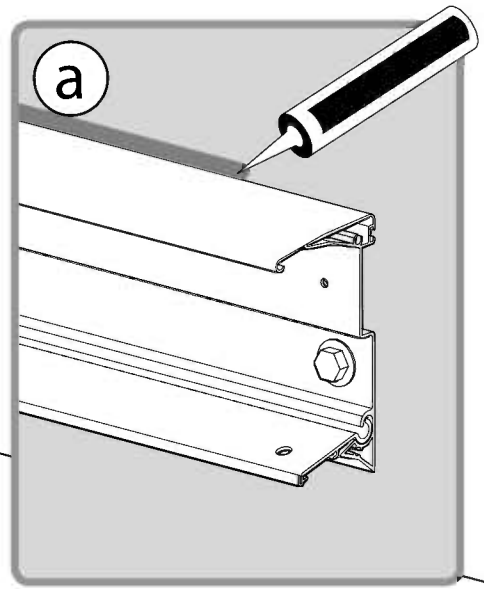

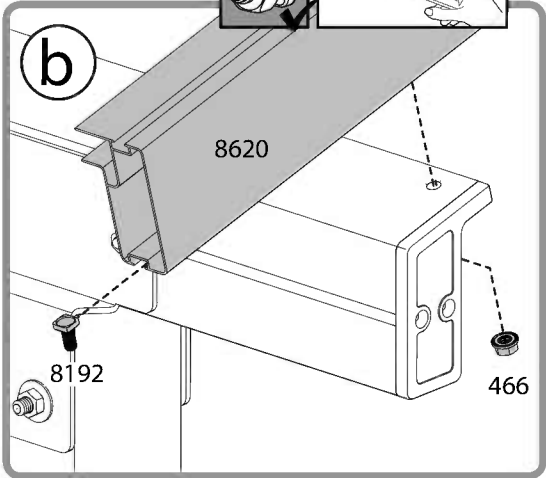
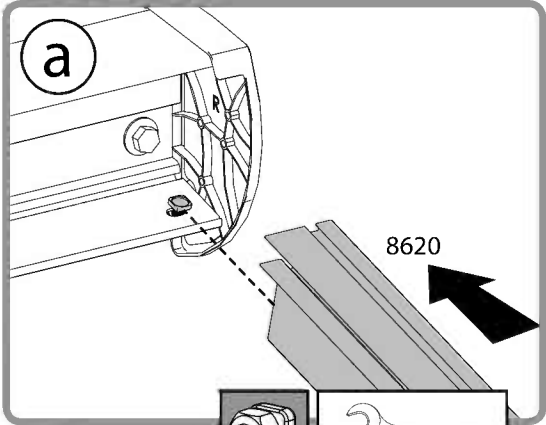
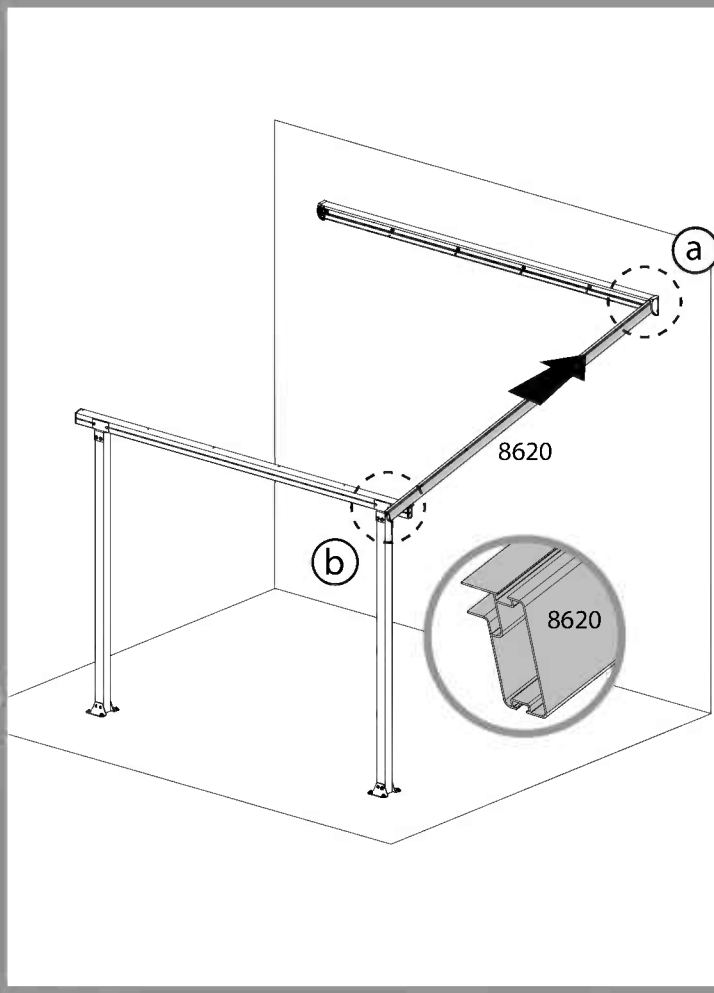
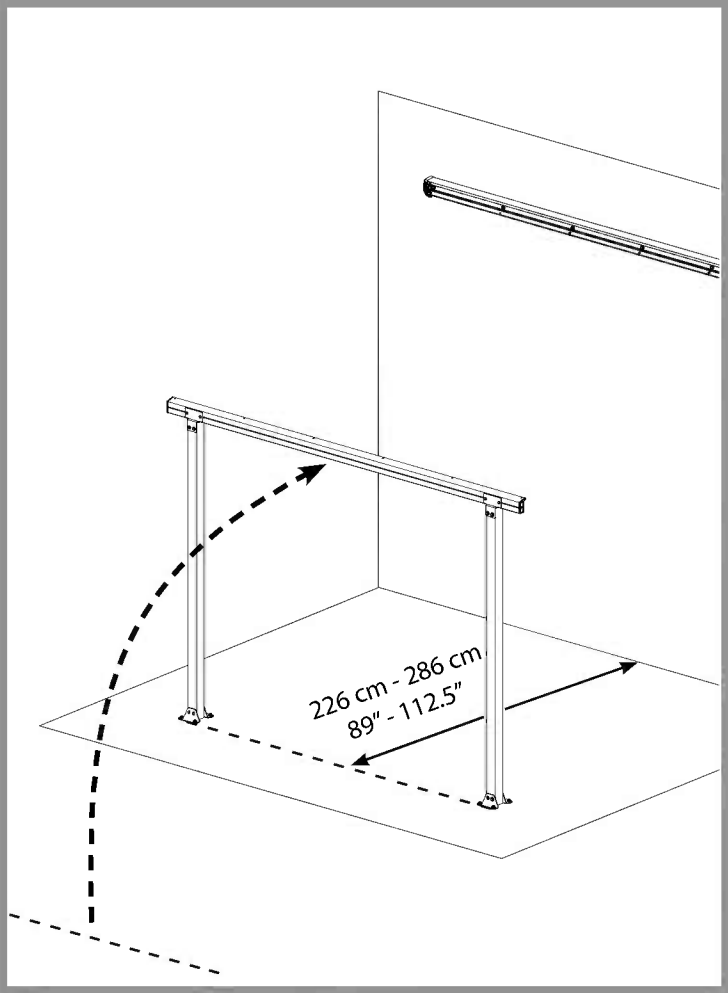
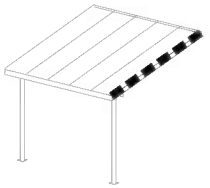

9 **i**

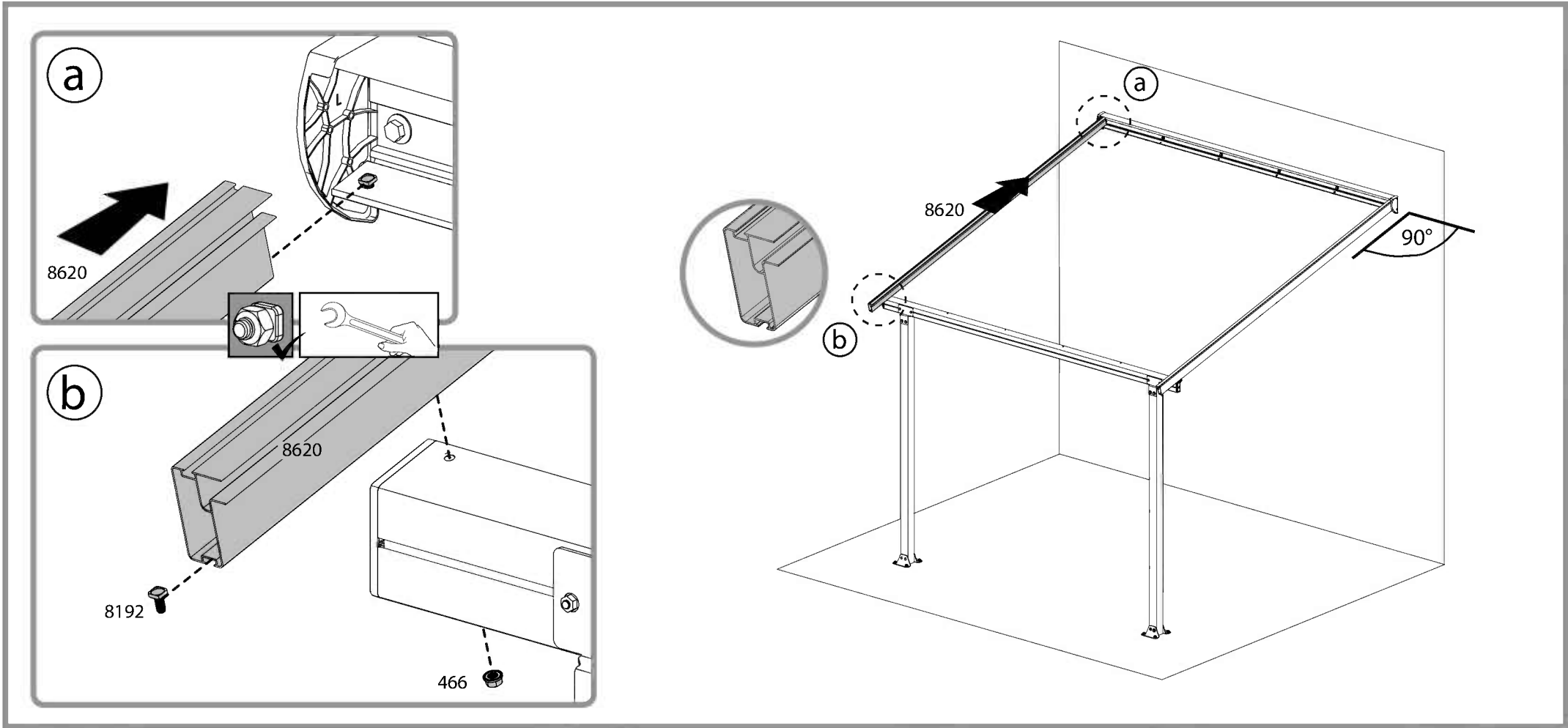
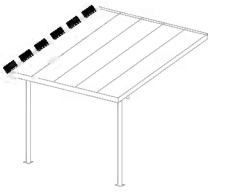

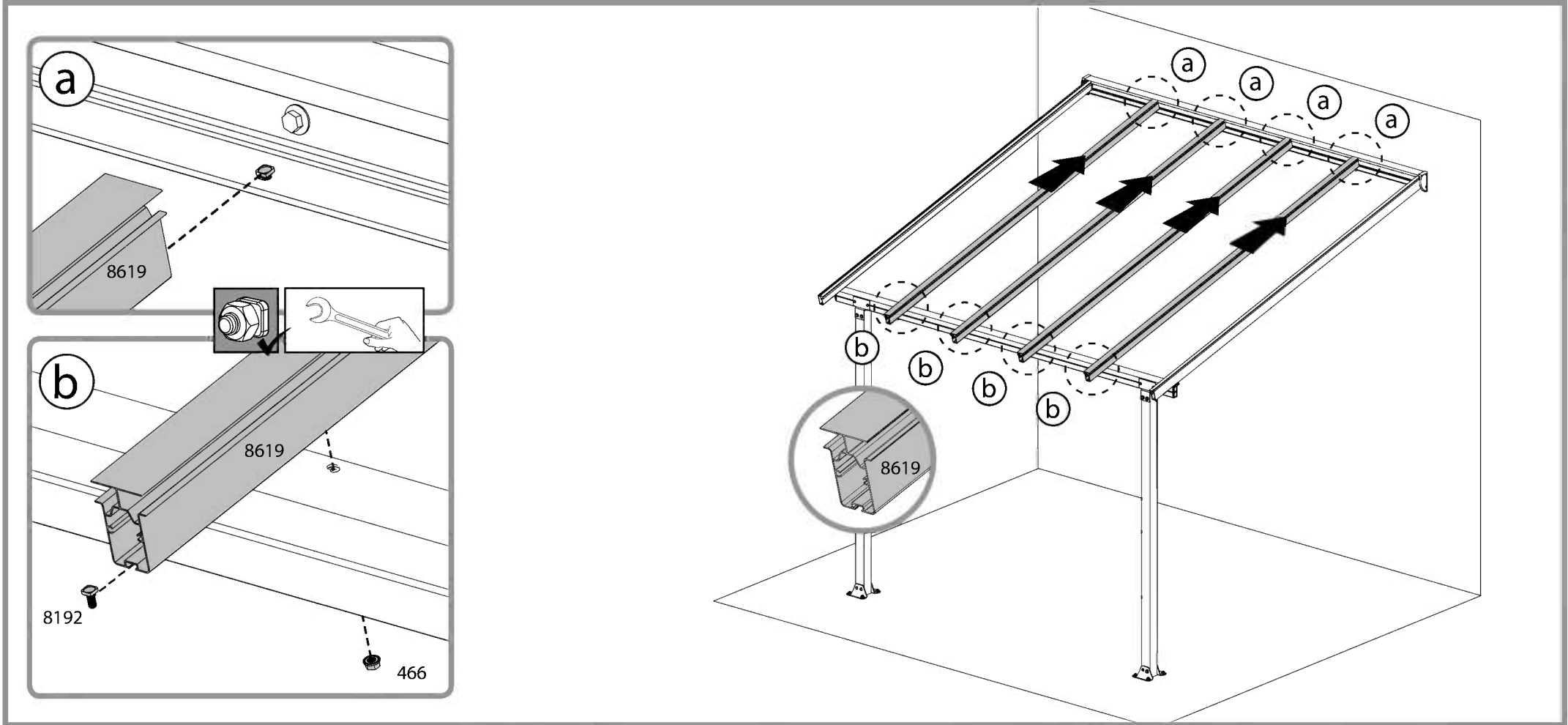
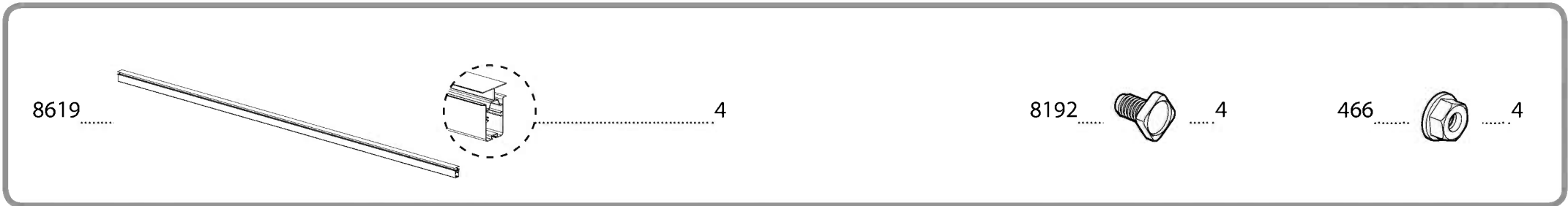
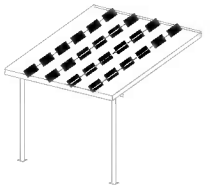

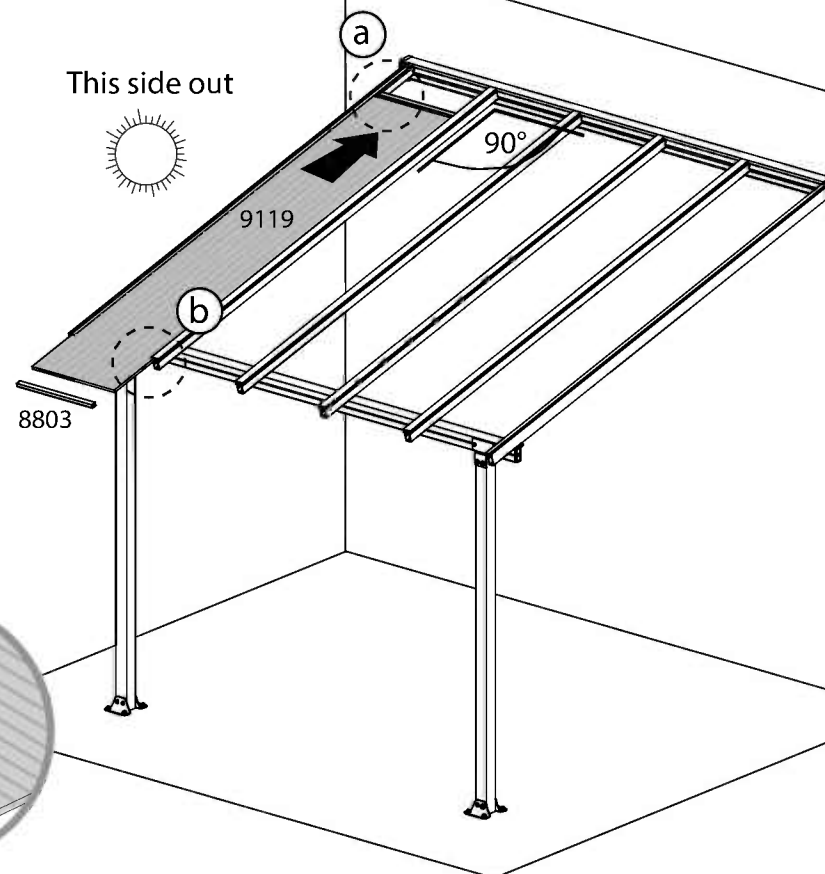
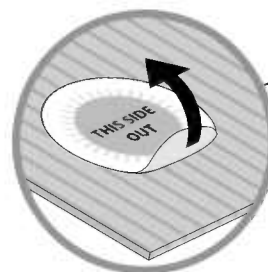
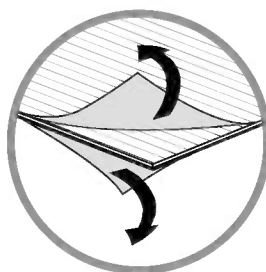
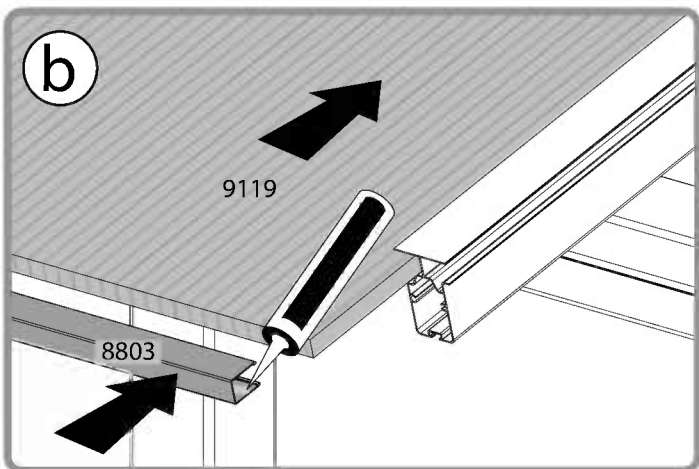
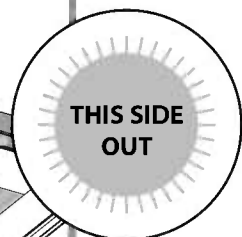
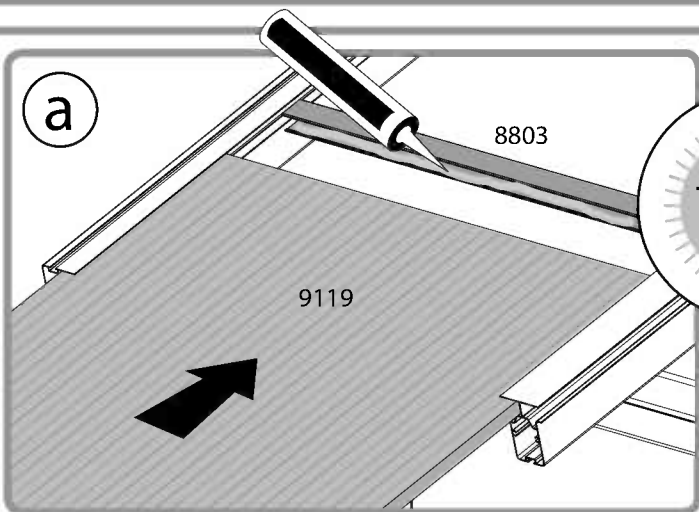
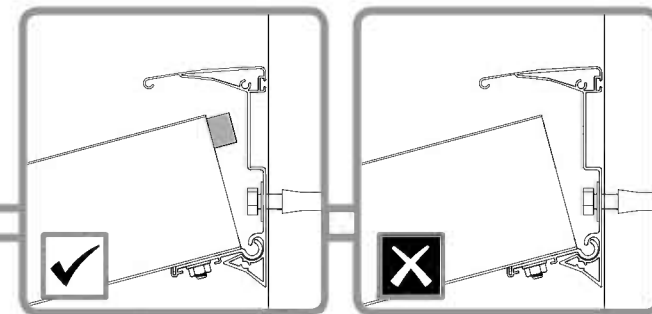

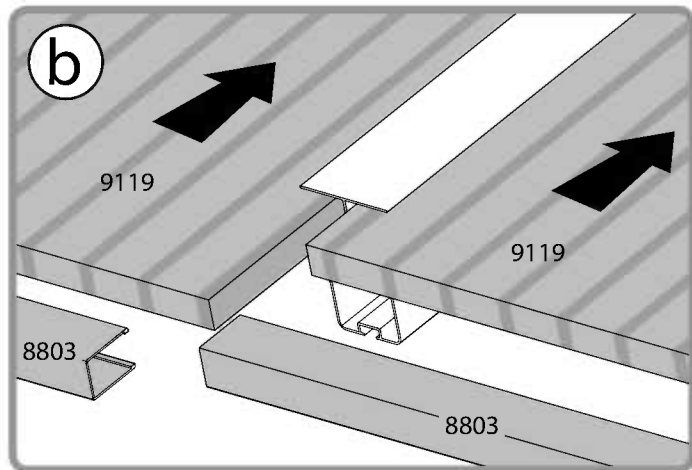
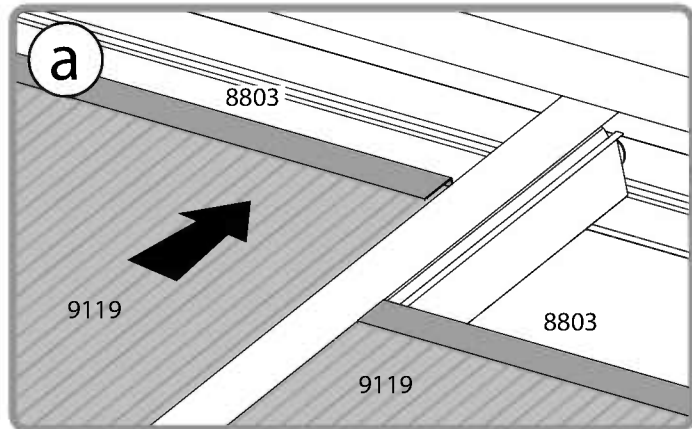
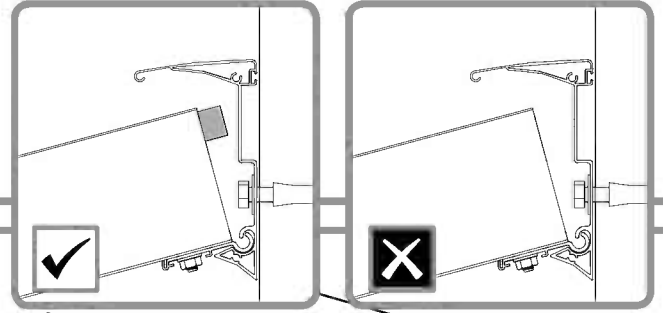
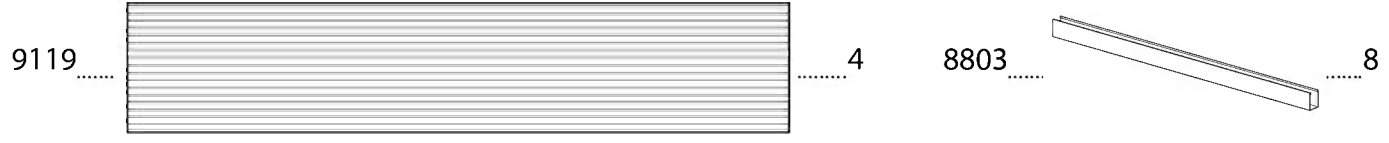

This side out

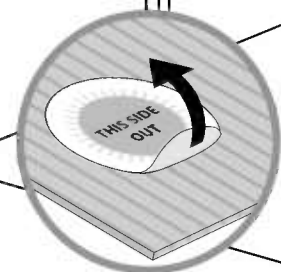
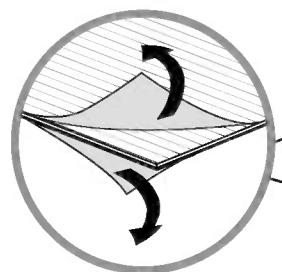
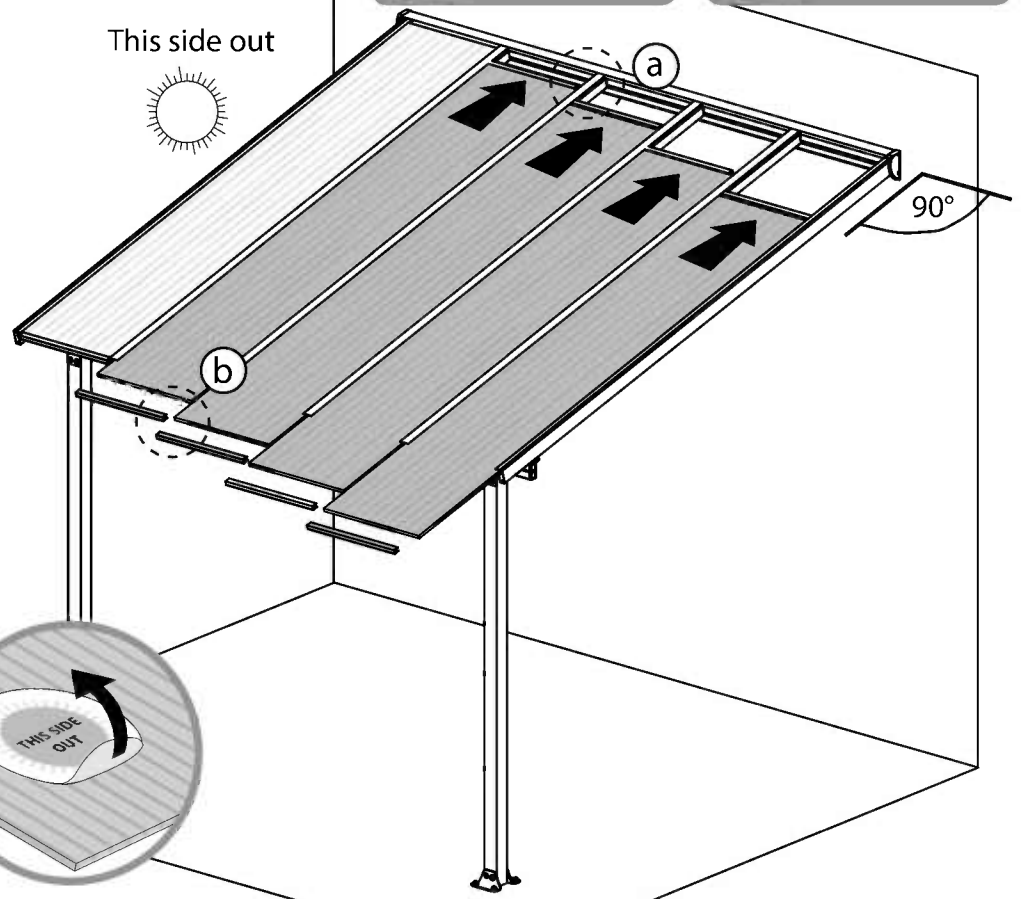

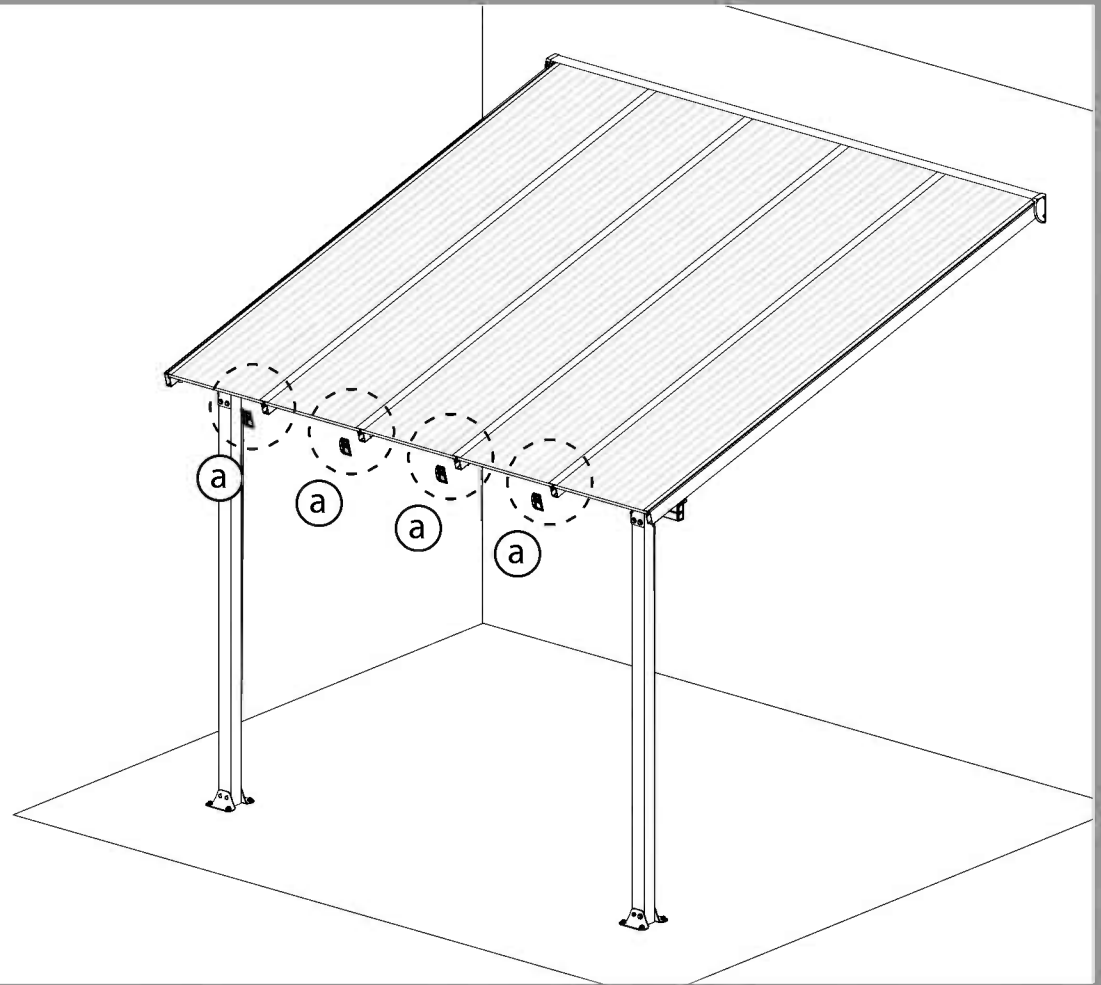
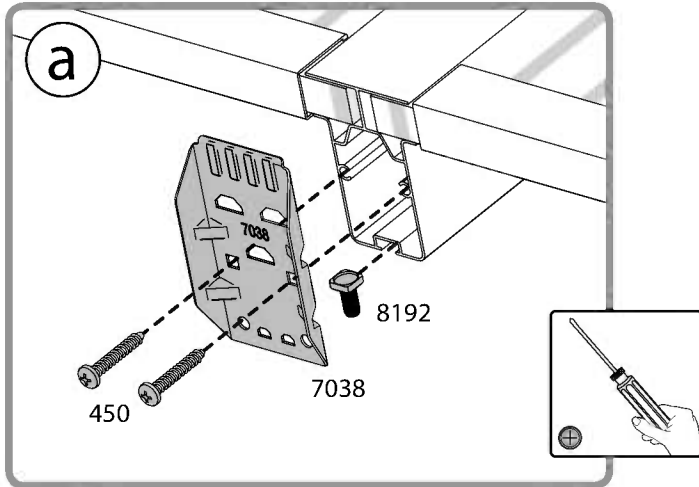
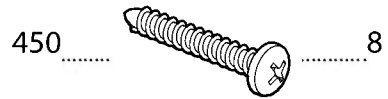
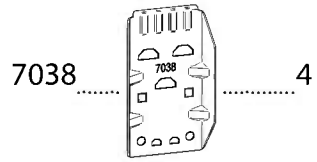

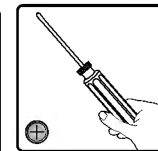
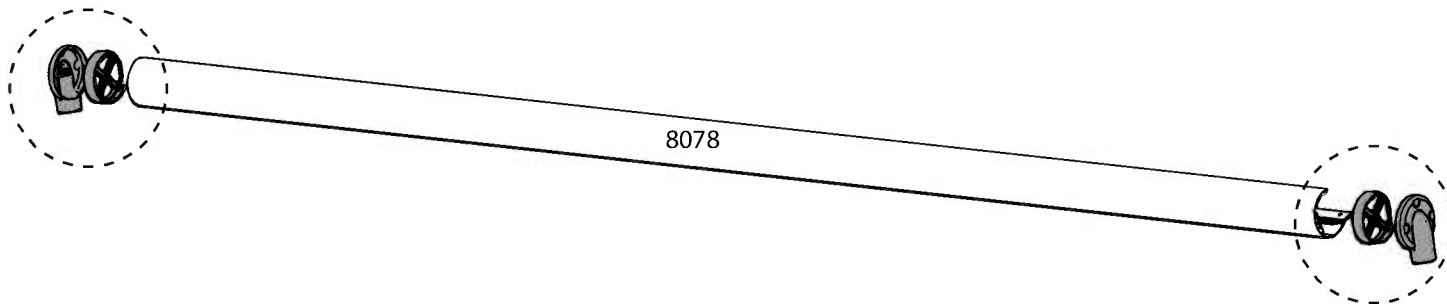
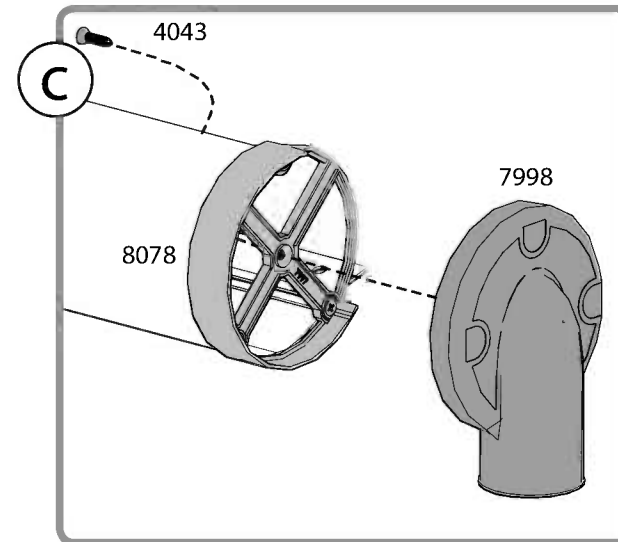
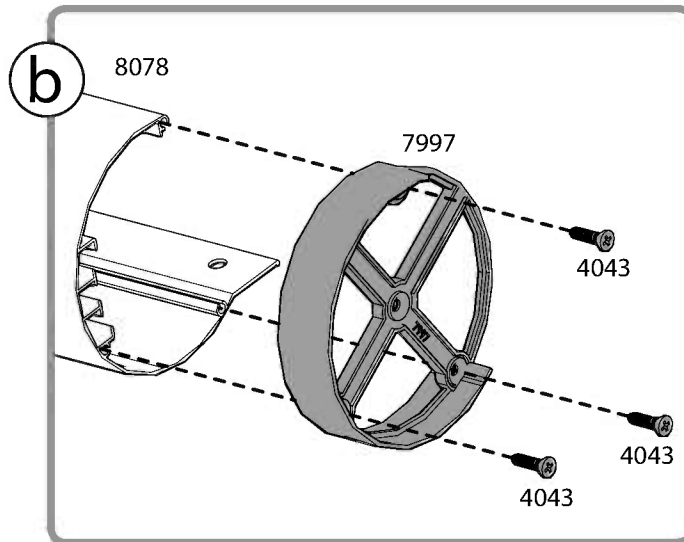
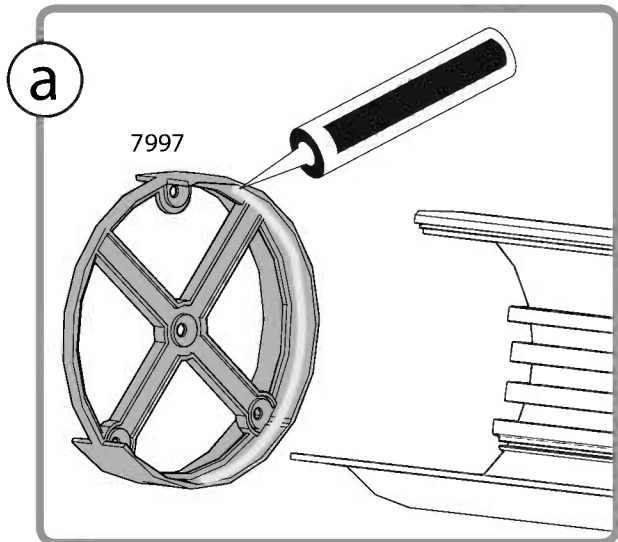
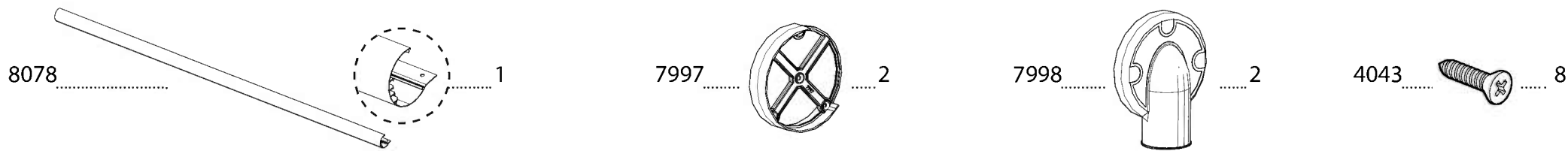



466 6

8192 2

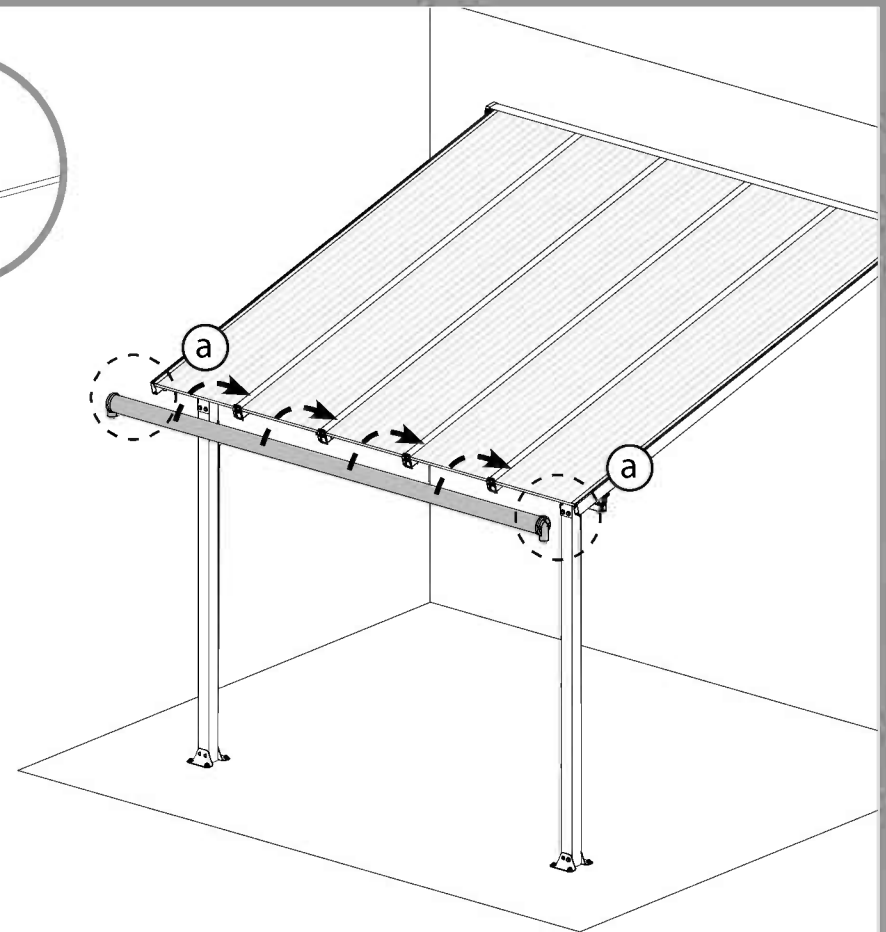
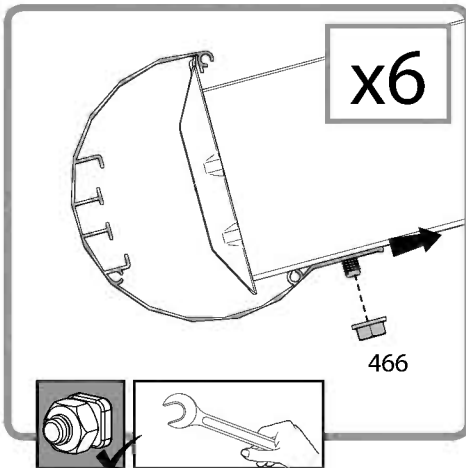
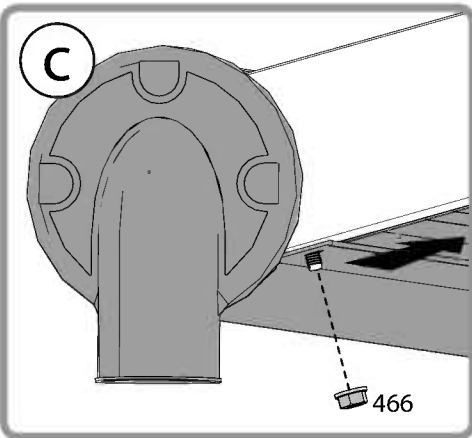
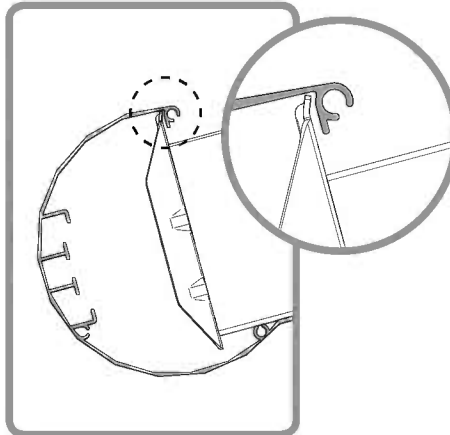
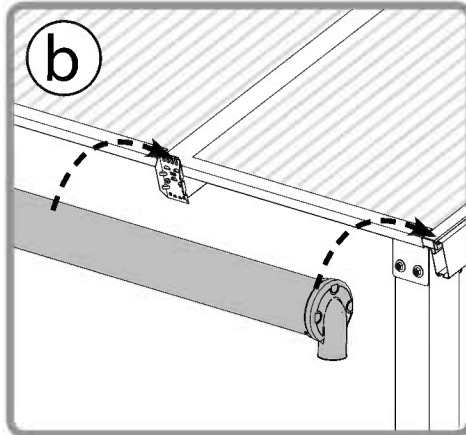
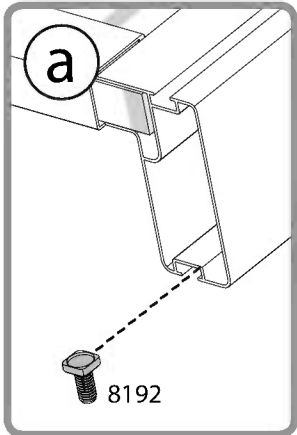

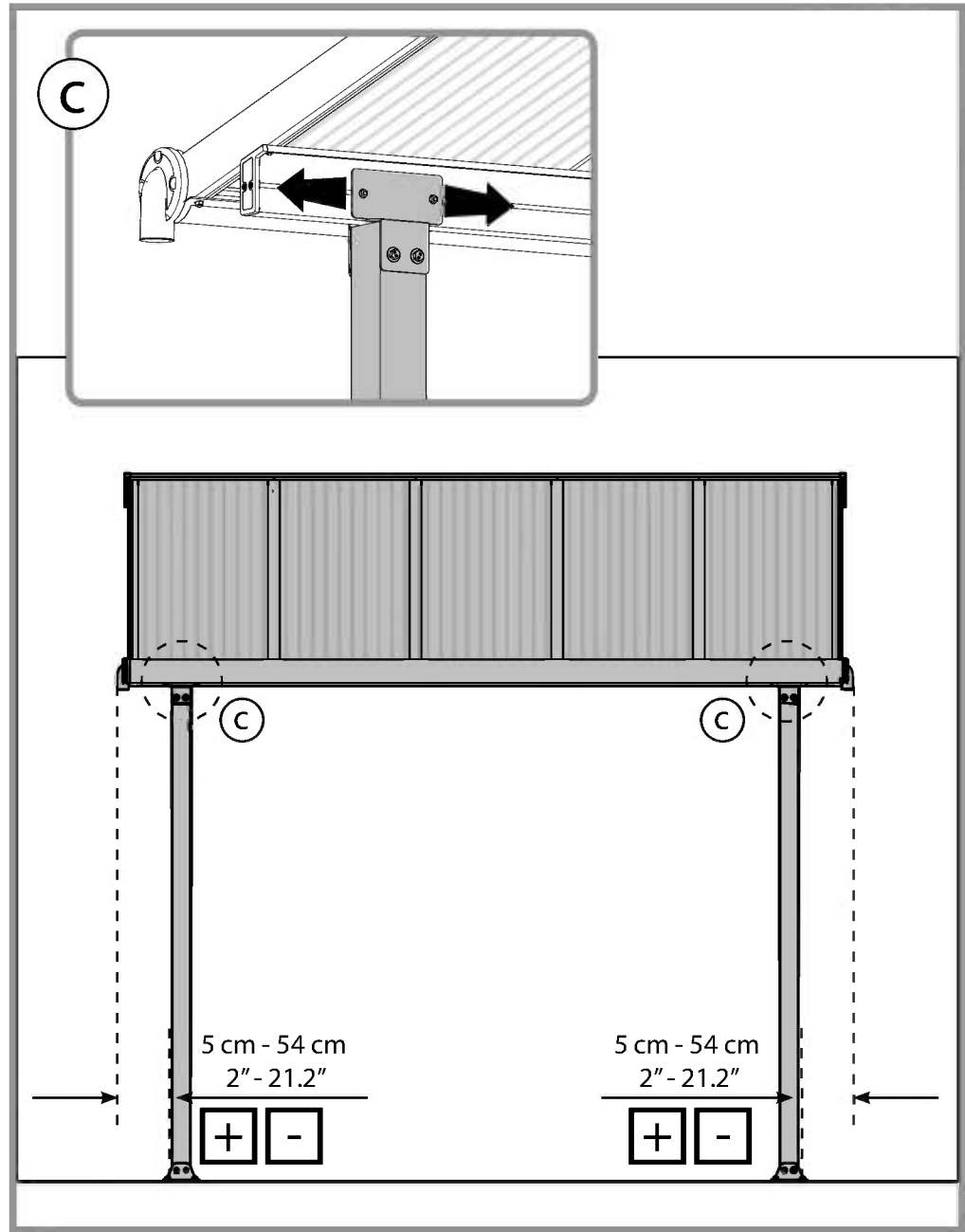
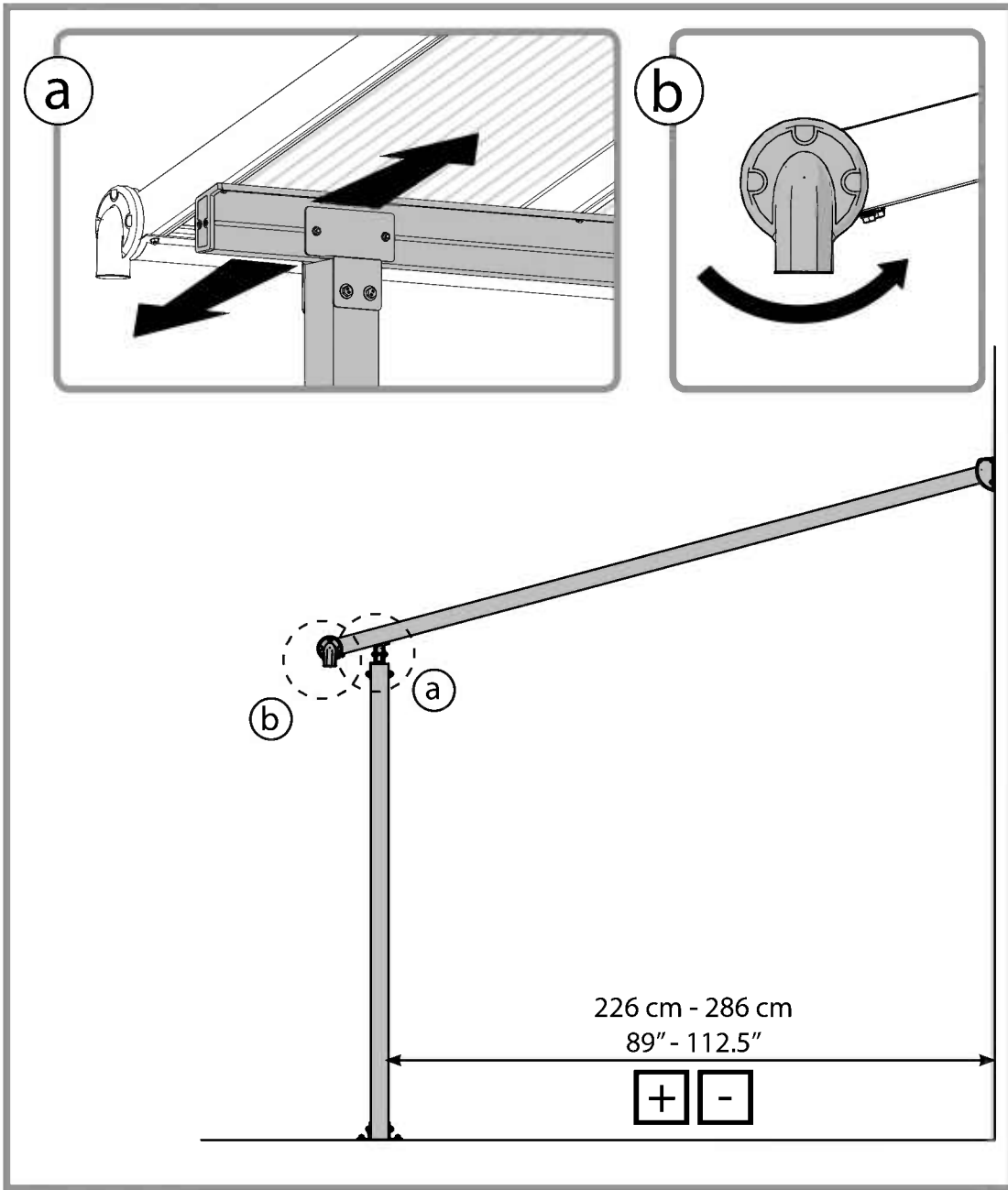

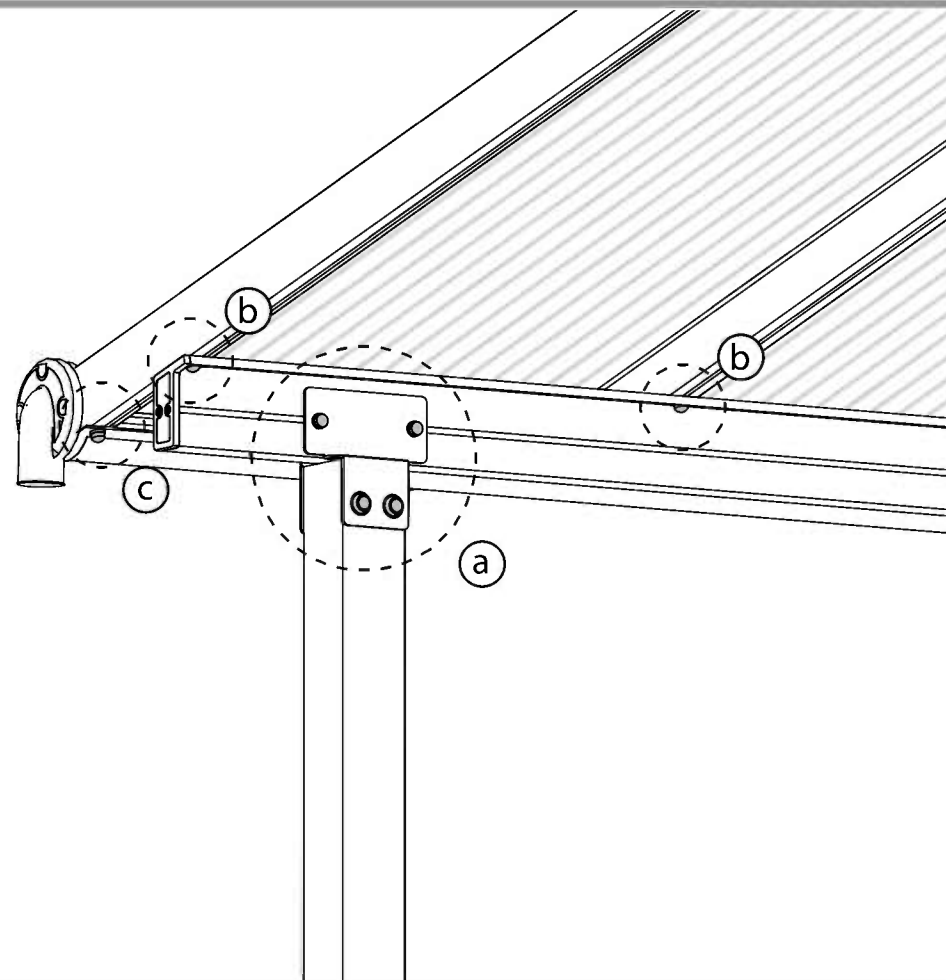
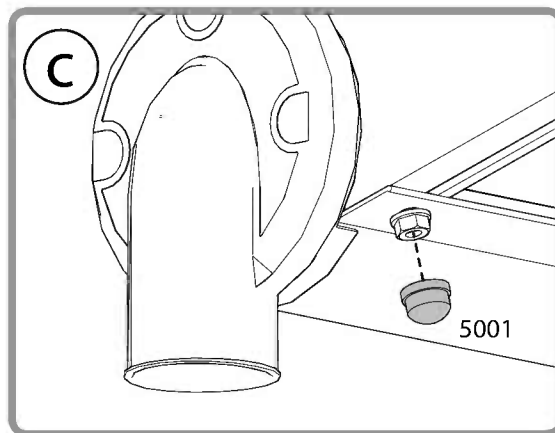
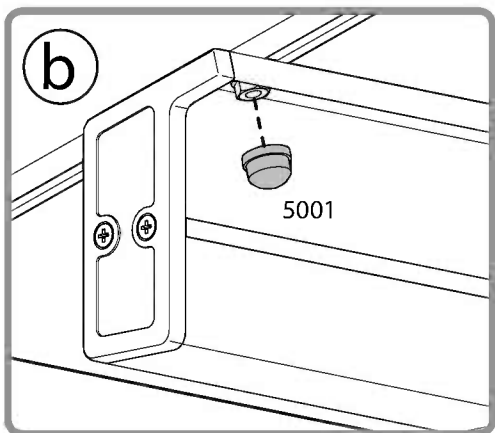
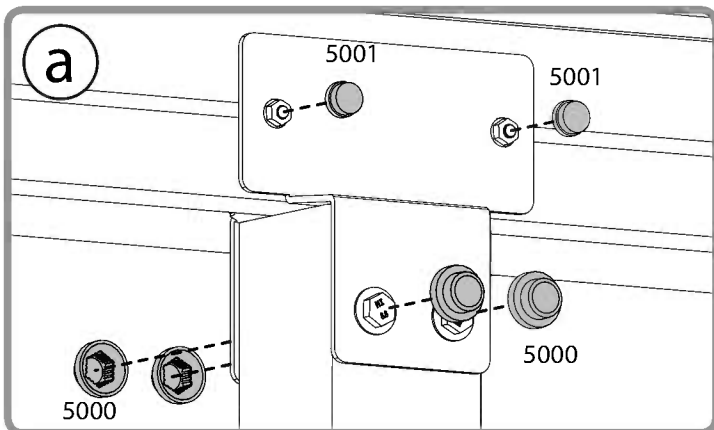
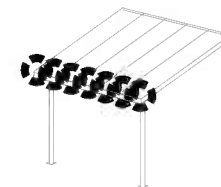

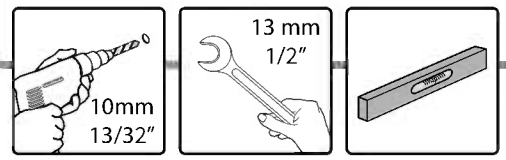
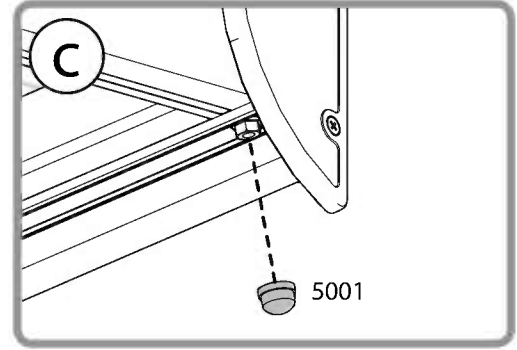
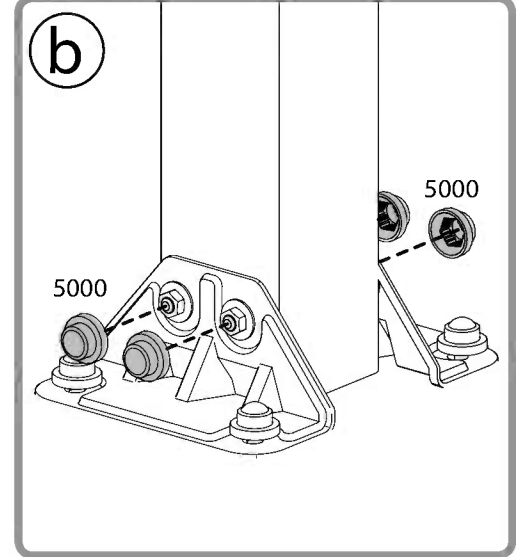
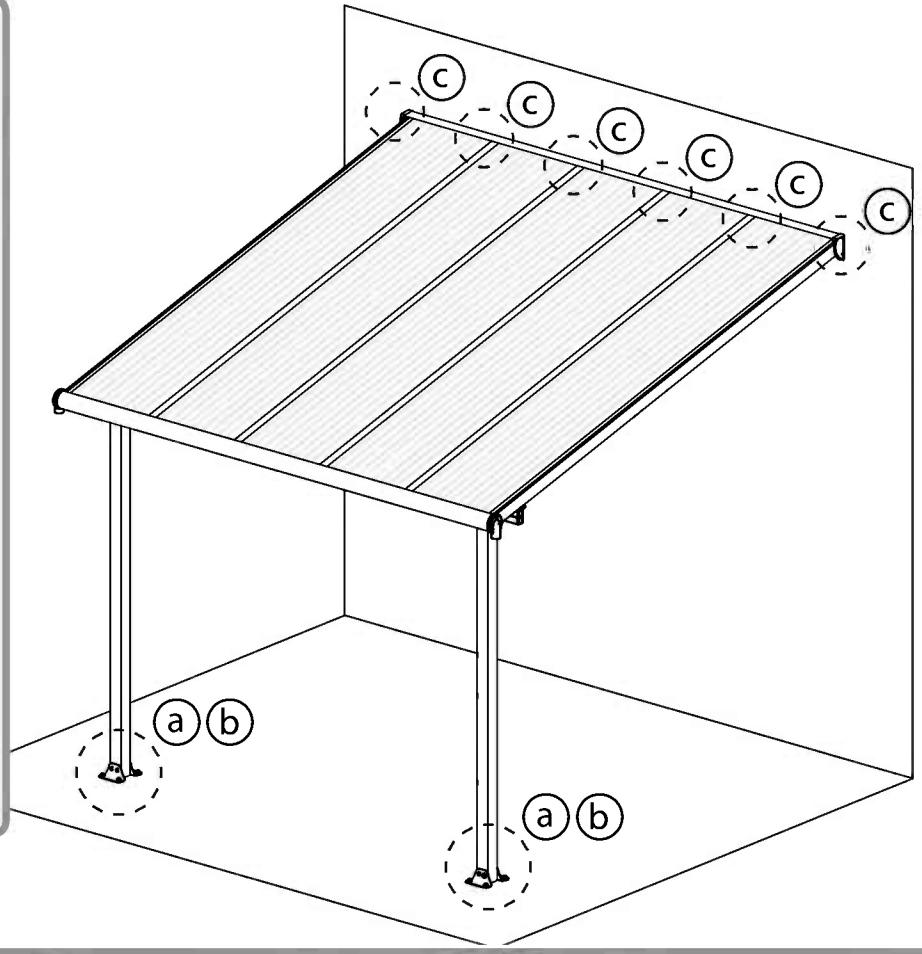
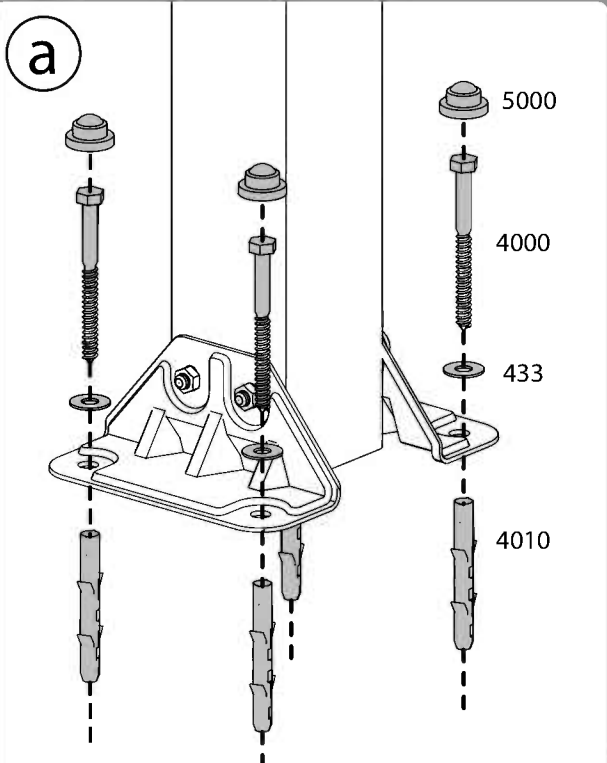
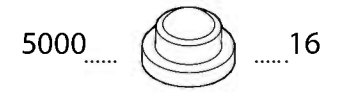
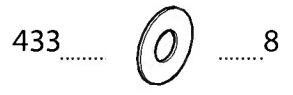
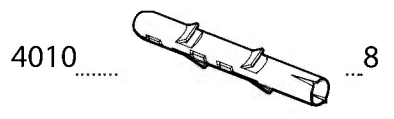
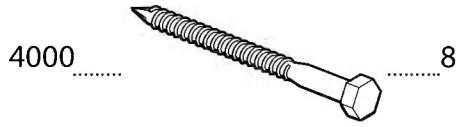
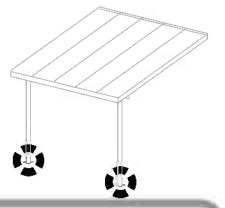

Declaration of Performance

According to Construction Products Council Directive UE N°305/2011 and EN 14963:2006
Issue Date 01/01/2022

1. Identification code: **Olympia™, refer to CE label no 054**
2. Type: A light transmitting wall-supported Twin-wall PC roofing structure with upstand made of aluminum and galvanized steel elements
3. Intended use: open multi-purpose covering
4. Manufacturer: Palram Canopia Ltd. Teradion Industrial Park, M.P Misgav 2017400, P.O.B. 53, Israel
5. Importer and EU representative : PALRAM Applications UK, Unit 40 J3 Industrial Estate Carr Hill, Doncaster DN4 8DE
6. Assessment and verification of constancy of performance: System 3
7. Declared performance:

Resistance to upward load: UL 1000

Resistance to downward loads: DL 1500

Reaction to fire: B, s1, d0
For mounting and fixing provisions see EN 16153:2013

Resistance to fire: NPD

External fire performance: FROOF

Water tightness:
For the rooflight with upstand: Pass
For the sheet material: Pass

Impact resistance:
For the small hard body: Pass
For the large soft body: NPD

Thermal transmittance:
For the rooflight: NPD (not relevant to an open multi purpose cover)
For the sheet material: 2.10 W/(m²•K)

Direct airborne sound insulation: NPD (not relevant to an open multi purpose cover)

Radiation transmittance:
- Light transmittance: Tv - 61.0 %
- Solar direct transmittance: Te - 49.1 %
- Solar factor: g value - 0.52

Air permeability:
For the rooflight: NPD (not relevant to an open multi purpose cover)
For the sheet material: Pass

Durability (of the sheet material): ΔA, Cu 1, Ku 1

8. The performance of the product identified in points 1 and 2 is in conformity with the declared performance in point 7.
This declaration of performance is issued, in accordance with Annex ZA.2.2 – EN 14963:2006,
under the sole responsibility of Palram Canopia Ltd.
ITT reports and Factory Production Control records are available upon request at www.canopia.com

Signed for and behalf of Palram Canopia Ltd. by:
Teradion Industrial Park, Misgav, 01/01/2022





CANOPIA[®]
by PALRAM

HOW TO ASSEMBLE

PATIO COVER EZ LINK™ KIT

Suitable for Patio Covers:

Feria, Sierra/Capri, Olympia, Tuscany, Carnival

IMPORTANT!

Please read these instructions carefully before starting assembly.
Keep these instructions in a safe place for future reference.

www.canopia.com



A member of
Palram Industries Ltd.

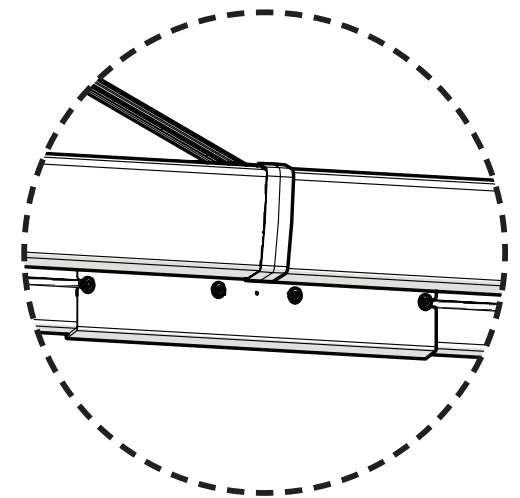
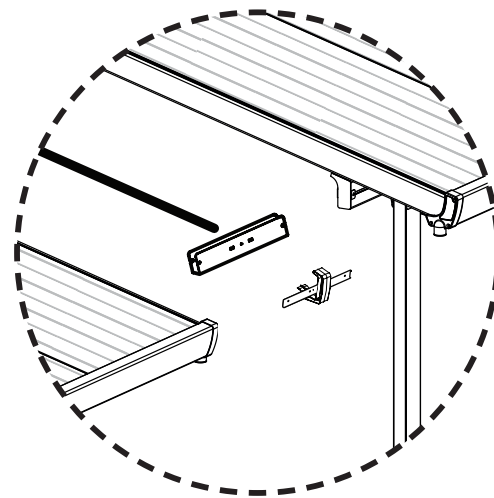

82776_22.02_MV-11.5

SAFETY ADVICE

- It is of utmost importance to assemble all of the parts according to the directions. Do not skip any steps.
- Always wear work gloves during panel sliding.
- Always wear shoes and safety goggles when working with extruded aluminium.
- If using a step ladder or power tools make sure that you follow the manufacturer's safety advice.
- Do not touch overhead power cables with the aluminium profiles.
- Do not climb or stand on the roof.
- Do not attempt to assemble the product in windy or wet conditions.
- Dispose of all plastic bags. Keep them out of reach of small children.
- Keep children away from the assembly area.
- Do not lean against or push the products during construction.
- Do not position your product in an area exposed to excessive winds.
- Do not attempt to assemble this product if you are tired, have taken drugs or alcohol or if you are prone to dizzy spells.

TOOLS & EQUIPMENT



Scissors

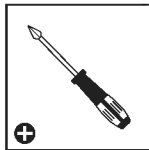

Phillips head Screwdriver

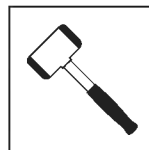

Rubber Mallet

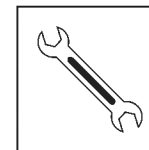

Wrench
10 mm | 3/8"

BEFORE ASSEMBLY

1. This product is suitable for Palram Canopia's Patio Covers range.
2. It is highly recommended to be assisted by a second person in some steps.
3. Sort the parts and check according to the contents parts list.
4. Prior to the installation, some parts of the Patio cover need to be dismantled, it is recommend to keep them in a safe place for future use.
5. Periodically check the kit's components to assure that it remains stable.
6. **Note:** Use only the parts registered in the content list, which are compatible with your Patio Cover's gutter (7999 & 8119), some parts may be surplus.

DURING ASSEMBLY



- During assembly you will encounter the information icon, please refer to the relevant assembly step for additional comments and assistance.



- This icon indicates that the installer should be inside the product.



- **Pay attention:** while installing the kit, alignment with original patio cover is important. Tighten all screws when completing assembly.



IMPORTANT ASSEMBLY STEPS

When encountering this information icon during assembly, please refer to the relevant assembly step for important additional comments.

Step 2: To assemble the rear profile please refer to the patio cover assembly manual at the stage of "holes marking" as:

Feria	Tuscany	Olympia	Sierra/Capri	Carnival
3x3 - Step 7	3x3 - Step 7	3x3 - Step 5	All sizes Step 5	3x3 - Step 6
3x4.25 - Step 6	3x4.25 - Step 9	3x4.25 - Step 7		3x4.25 - Step 5
3x5.46 - Step 9	3x5.46 - Step 9	3x5.46 - Step 7		-
4x4.25 - Step 12	-	-		-

* For fixation to the wall, return to **step 2**.

Step 3: Connect part **8303 (drawings a,b)** and then return to the patio cover assembly manual as follow:

Feria	Tuscany	Olympia	Sierra/Capri	Carnival
3x3 - Step 8	3x3 - Step 8	3x3 - Step 6	2.3x2.3 - Step 7	3x3 - Step 10
3x4.25 - Step 13	3x4.25 - Step 13	3x4.25 - Step 11	3x3 - Step 6	3x4.25 - Step 9
3x5.46 - Step 13	3x5.46 - Step 13	3x5.46 - Step 11	3x4.25 - Step 9	-
4x4.25 - Step 16	-	-	3x5.46 - Step 9	-

* After completion, perform **drawing c** at this step.

Step 4: In all relevant patio cover sizes, you may choose either of these 2 assembly options:

Option 1 (Steps 4+5+6+9+10+11+12) - assembling all posts supplied.

Option 2 (Steps 4+7+8+9+10+11+12) - Whenever you are using this EZ Link Kit you may give up using one leg.

Step 6: (**Option 1**): make sure the distance between the post and the connection point does not exceed 60 cm / 23.6 inch. The Maximum distance between the posts may not exceed 120 cm / 47.2 inch.

Step 10: Before performing this stage, return to the patio cover assembly manual at the stage of "assembling the roof system" as follow:

Feria	Tuscany	Olympia	Sierra/Capri	Carnival
3x3 - Step 15	3x3 - Step 14	3x3 - Step 11	2.3x2.3 - Step 12	3x3 - Step 18
3x4.25 - Step 22	3x4.25 - Step 20	3x4.25 - Step 17	3x3 - Step 11	3x4.25 - Step 16
3x5.46 - Step 21	3x5.46 - 20 Step	3x5.46 - Step 17	3x4.25 - Step 15	-
4x4.25 - Step 26	-	-	3x5.46 - Step 15	-

Step 12: Tightening the bolts is done from the inner part. Spread silicone follow the connection (a,b).

CONSEILS DE SECURITE

- Très important ! Veuillez suivre scrupuleusement les instructions de ce manuel et réaliser les étapes dans l'ordre énoncé.
- Nous recommandons vivement le port de gants de protection pendant le montage.
- Portez toujours des chaussures de travail et des lunettes de protection lorsque vous travaillez des pièces en aluminium extrudé.
- Lors de l'utilisation d'une échelle ou d'outils électriques, assurez-vous de bien suivre les consignes de sécurité du fabricant.
- Veillez à ne pas toucher de câbles aériens avec les profilés en aluminium.
- Ne montez pas sur le toit.
- N'essayez pas de monter la produit s'il y a du vent ou s'il fait humide.
- Jetez tous les sacs en plastique en appliquant les règles de sécurité et maintenez-les hors de portée des jeunes enfants.
- Eloignez les enfants de la zone d'assemblage.
- Ne vous appuyez pas contre la produit et ne la poussez pas pendant le montage.
- Ne positionnez pas la produit dans un endroit trop exposé au vent.
- N'essayez pas de monter la produit si vous êtes fatigué, si vous êtes sous l'effet de drogues, de médicaments ou d'alcool ou encore si vous êtes sujet aux vertiges.

TOOLS & EQUIPMENT

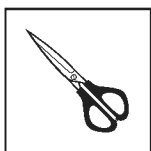

Ciseaux



Tournevis cruciforme

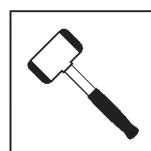

Maillet en caoutchouc

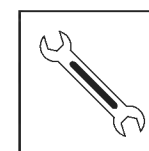

Clé
10 mm | 3/8"

AVANT L'ASSEMBLAGE

1. Ce produit est adapté pour les Gamme Couvres Patio de Palram Canopia's.
2. Il est vivement recommandé d'être assisté par une deuxième personne lors de l'installation.
3. Triez les pièces et vérifiez selon la liste de contenu.
4. Avant l'installation, certaines parties du couvre Patio doivent être démontés, il est recommandé de les conserver dans un endroit sûr pour besoin ultérieurs.
5. Vérifiez les éléments du kit régulièrement afin de s'assurer qu'il reste stable.
6. **Remarque:** Utilisez uniquement les pièces indiquées sur la liste de contenu qui correspondent à votre pergola garçons (7999 & 8119). Certaines pièces faillissent être excédentaires.

DURANT L'ASSEMBLAGE



- Pendant le montage, vous verrez l'icône d'information, veuillez-vous référer à la phase de montage correspondante pour des commentaires et une assistance supplémentaires.



- Cette icône indique que le constructeur doit se placer à l'intérieur du produit



- Lors de l'installation du kit il est important d'aligner le couvre patio original. Renforcez toutes les vis dès que l'assemblage est achevé.



PRINCIPALES ÉTAPES D'ASSEMBLAGE

Lorsque vous rencontrez cette icône d'information pendant l'assemblage, veuillez vous référer à l'étape d'assemblage correspondante pour d'autres commentaires importants.

Étape 2: Pour assembler le profil arrière, veuillez vous référer au manuel d'assemblage de la couverture de terrasse au stade du "marquage des trous" comme:

Feria	Tuscany	Olympia	Sierra/Capri	Carnival
3x3 - Étape 7	3x3 - Étape 7	3x3 - Étape 5	Todos los tamaños Étape 5	3x3 - Étape 6
3x4.25 - Étape 6	3x4.25 - Étape 9	3x4.25 - Étape 7		3x4.25 - Étape 5
3x5.46 - Étape 9	3x5.46 - Étape 9	3x5.46 - Étape 7		-
4x4.25 - Étape 12	-	-		-

* Pour la fixation au mur, revenez à l'étape 2.

Étape 3: Connectez la pièce 8303 (dessins a, b), puis revenez au manuel d'assemblage de la couverture de terrasse comme suit:

Feria	Tuscany	Olympia	Sierra/Capri	Carnival
3x3 - Étape 8	3x3 - Étape 8	3x3 - Étape 6	2.3x2.3 - Étape 7	3x3 - Étape 10
3x4.25 - Étape 13	3x4.25 - Étape 13	3x4.25 - Étape 11	3x3 - Étape 6	3x4.25 - Étape 9
3x5.46 - Étape 13	3x5.46 - Étape 13	3x5.46 - Étape 11	3x4.25 - Étape 9	-
4x4.25 - Étape 16	-	-	3x5.46 - Étape 9	-

* Une fois terminé, effectuez le dessin c à cette étape.

Étape 4: Dans toutes les tailles de couverture de terrasse pertinentes, vous pouvez choisir l'une de ces 2 options d'assemblage:

Option 1 (étapes 4+5+6+9+10+11+12) - assemblage de tous les poteaux fournis.

Option 2 (étapes 4+7+8+9+10+11+12) - Chaque fois que vous utilisez ce kit EZ Link, vous pouvez abandonner l'utilisation d'une jambe.

Étape 6: (Option 1): assurez-vous que la distance entre le poteau et le point de connexion ne dépasse pas 60 cm / 23,6 pouces. La distance maximale entre les poteaux ne doit pas dépasser 120 cm / 47,2 pouces.

Étape 10: Avant d'effectuer cette étape, revenez au manuel d'assemblage de la couverture de terrasse au stade de "assembler le système de toiture" comme suit:

Feria	Tuscany	Olympia	Sierra/Capri	Carnival
3x3 - Étape 15	3x3 - Étape 14	3x3 - Étape 11	2.3x2.3 - Étape 12	3x3 - Étape 18
3x4.25 - Étape 22	3x4.25 - Étape 20	3x4.25 - Étape 17	3x3 - Étape 11	3x4.25 - Étape 16
3x5.46 - Étape 21	3x5.46 - Étape 20	3x5.46 - Étape 17	3x4.25 - Étape 15	-
4x4.25 - Étape 26	-	-	3x5.46 - Étape 15	-

Étape 12: Le serrage des boulons se fait à partir de la partie intérieure. Étaler du silicone suivre la connexion (a, b).

SICHERHEITSHINWEISE

- Es ist sehr wichtig, dass alle Teile gemäß den Anweisungen in dieser Anleitung zusammengebaut werden. Lassen Sie bitte keinen Schritt aus.
- Tragen Sie bei der Montage unbedingt Arbeitshandschuhe. Wir empfehlen Ihnen außerdem dringend, festes Schuhwerk und eine Schutzbrille zu tragen.
- Achten Sie beim verwenden einer Leiter oder Elektrowerkzeug bitte auf die jeweiligen Sicherheitshinweise des Herstellers.
- Berühren Sie mit den Aluminiumprofilen keine Oberleitungen.
- Halten Sie Kinder vom Aufbaubereich fern.
- Die Montage darf nur bei trockenem und windstillem Wetter erfolgen.
- Nicht auf das Dach klettern oder darauf stehen.
- Entsorgen Sie alle Plastikbeutel sicher und bewahren sie außerhalb der Reichweite von Kleinkindern auf.
- Während des Aufbaus sollten Sie sich nicht gegen das Produkt lehnen oder Druck ausüben.
- Suchen Sie einen windgeschützten Standort für das Produkt aus.
- Versuchen Sie nicht, dieses Produkt zu montieren, wenn Sie müde sind, Drogen oder Alkohol zu sich genommen haben oder zu Schwindelanfällen neigen.
- Bevor Sie das Produkt im Fundament verankern, vergewissern Sie sich, dass sich dort keine versteckten Rohre oder Kabel befinden.

WERKZEUGE & AUSRÜSTUNG



Schere

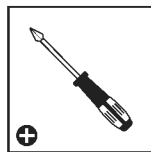

Kreuzschlitzschraubendreher

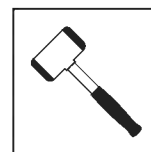

Gummihammer

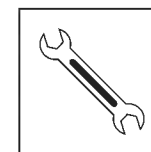

Schraubenschlüssel
10 mm | 3/8"

VOR DEM ZUSAMMENBAU

1. Dieses Produkt eignet sich für alle Pergolen der Firma Palram Canopia's.
2. Es wird dringend empfohlen, von einer zweiten Person in einigen Schritten assistiert zu werden.
3. Das Produkt muss auf einer ebenen Oberfläche positioniert und fixiert werden.
4. Vor der Installation, müssen mehrere Teile aus der Patio Abdeckung abmontiert werden, es wird empfohlen, diese an einem sicheren Ort für den zukünftigen Gebrauch aufzubewahren.
5. Überprüfen Sie regelmäßig die Bauteile dieses Sets, um sicherzustellen, dass es stabil bleibt.
6. **Hinweis:** Verwenden Sie nur die in der Inhaltsliste registrierten Teile, die mit Ihrer Patio-Abdeckung kompatibel sind Jungs (7999 & 8119), einige Teile können überzählig sein.

WÄHREND DER MONTAGE



- Wenn Sie dieses Infozeichen Begegnen, dann achten Sie bitte bei dem entsprechenden Montageschritt auf zusätzliche Kommentare und Helfende Zusatzinformation.



- Dieses Symbol zeigt an, dass der Einbauer im Innenraum des Produktes sein sollte.



- **Bitte Beachten Sie:** Bei der Installation des Bausatzes, ist die Ausrichtung zur original Patio. Abdeckung sehr wichtig Ziehen Sie alle Schrauben fest an, nach dem Sie die Montage beendet haben.



WICHTIGE MONTAGESCHRITTE

Wenn Sie bei der Montage auf dieses Informationssymbol stoßen, finden Sie im jeweiligen Montageschritt wichtige Zusatzhinweise.

Schritt 2: Informationen zum Zusammenbau des hinteren Profils finden Sie in der Montageanleitung für die Terrassenabdeckung im Teil **“Lochmarkierung”** wie folgt:

Feria	Tuscany	Olympia	Sierra/Capri	Carnival
3x3 - Schritt 7	3x3 - Schritt 7	3x3 - Schritt 5	Alle Größen Schritt 5	3x3 - Étape 6
3x4.25 - Schritt 6	3x4.25 - Schritt 9	3x4.25 - Schritt 7		3x4.25 - Étape 5
3x5.46 - Schritt 9	3x5.46 - Schritt 9	3x5.46 - Schritt 7		-
4x4.25 - Schritt 12	-	-		-

* Zur Befestigung an der Wand Kehren Sie zu **Schritt 2** zurück.

Schritt 3: Schließen Sie Teil **8303 (Zeichnungen a, b)** an und kehren Sie dann wie folgt zur Montageanleitung für die Terrassenabdeckung zurück:

Feria	Tuscany	Olympia	Sierra/Capri	Carnival
3x3 - Schritt 8	3x3 - Schritt 8	3x3 - Schritt 6	2.3x2.3 - Schritt 7	3x3 - Schritt 10
3x4.25 - Schritt 13	3x4.25 - Schritt 13	3x4.25 - Schritt 11	3x3 - Schritt 6	3x4.25 - Schritt 9
3x5.46 - Schritt 13	3x5.46 - Schritt 13	3x5.46 - Schritt 11	3x4.25 - Schritt 9	-
4x4.25 - Schritt 16	-	-	3x5.46 - Schritt 9	-

* Führen Sie nach Abschluss dieses Vorgangs das in **Zeichnung c** abgebildete aus.

Schritt 4: Bei allen relevanten Terrassenabdeckungsgrößen können Sie eine dieser beiden Montageoptionen auswählen:

Option 1 (Schritte 4+5+6+9+10+11+12) - Zusammenbau aller gelieferten Pfosten.

Option 2 (Schritte 4+7+8+9+10+11+12) - Wenn Sie dieses EZ Link Kit verwenden, können Sie einen Pfosten weglassen.

Schritt 6: (**Option 1**): Stellen Sie sicher, dass der Abstand zwischen dem Pfosten und dem Verbindungspunkt 60 cm nicht überschreitet. Der maximale Abstand zwischen den Pfosten darf 120 cm nicht überschreiten.

Schritt 10: Schritt 10: Bevor Sie diese Phase durchführen, kehren Sie bei der Phase der **“Montage des Dachsystems”** wie folgt zur Montageanleitung für die Terrassenabdeckung zurück:

Feria	Tuscany	Olympia	Sierra/Capri	Carnival
3x3 - Schritt 15	3x3 - Schritt 14	3x3 - Schritt 11	2.3x2.3 - Schritt 12	3x3 - Schritt 18
3x4.25 - Schritt 22	3x4.25 - Schritt 20	3x4.25 - Schritt 17	3x3 - Schritt 11	3x4.25 - Schritt 16
3x5.46 - Schritt 21	3x5.46 - Schritt 20	3x5.46 - Schritt 17	3x4.25 - Schritt 15	-
4x4.25 - Schritt 26	-	-	3x5.46 - Schritt 15	-

Schritt 12: Das Anziehen der Schrauben erfolgt vom Innenteil aus. Verteilen Sie Silikon entlang der Verbindung (a, b).

CONSEJOS DE SEGURIDAD

- Es de suma importancia montar todas las partes de acuerdo con las instrucciones. No se salte ningún paso.
- Recomendamos firmemente el uso de guantes de trabajo durante el montaje.
- Use siempre zapatos y gafas de seguridad al trabajar con aluminio extruido.
- Al usar una escalera plegable o herramientas eléctricas asegúrese de que sigue las instrucciones de seguridad de los fabricantes.
- No toque los cables eléctricos aéreos con los perfiles de aluminio.
- No trepe ni se ponga de pie en el tejado.
- No intente montar el invernadero en días de viento o días con humedad.
- Disponga todas las bolsas plásticas en lugar seguro - guárdelas fuera del alcance de niños.
- Mantenga a los niños fuera del área de montaje.
- No se apoye ni empuje el producto durante la construcción.
- No coloque su producto en un área expuesta al viento excesivo.
- No intente montar este producto si usted está cansado, ha tomado drogas o alcohol o si usted es propenso a ataques de mareo.

CUIDADOS & MANTENIMIENTO



☐ Tijeras

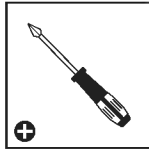

☐ Destornillador de cabeza Philips

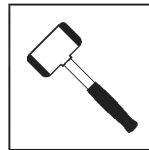

☐ Martillo de goma

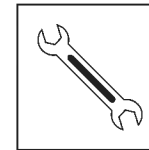

☐ Llave
10 mm | 3/8"

ANTES DEL MONTAJE

1. Este producto es compatible con la gama de Cubiertas de Patio de Palram Canopia's.
2. Se recomienda ser asistido por otra persona en el proceso de instalación.
3. Ordene todas las piezas y verifíquelas de acuerdo con el índice de contenido.
4. Antes de comenzar la instalación, algunas partes de la cubierta del patio deben ser desmontadas, se recomienda guardarlas en un lugar seguro para necesidades futuras.
5. Revise periódicamente los componentes del kit para comprobar que se mantenga estable.
6. **Atención:** use solo las piezas que aparecen en la lista del contenido chicos, (7999 & 8119), puede haber algunas piezas de sobra.

DURANTE EL MONTAJE



- Cuando vea el icono de información, por favor consulte el paso de montaje pertinente para disponer de más comentarios y ayuda.



- Este icono indica que el instalador debe estar dentro del producto.



- **Ponga cuidado:** al instalar el kit, es importante mantener la alineación con la cubierta del patio original. Cuando termine el montaje, apriete bien todos los tornillos.



PASOS DE MONTAJE IMPORTANTES

Al encontrar este icono de información durante el montaje, consulte el paso de montaje correspondiente para obtener importantes comentarios adicionales.

Paso 2: Para ensamblar el perfil posterior, consulte el manual de montaje de la cubierta de patio en el paso de “**marcado de agujeros**” según:

Feria	Tuscany	Olympia	Sierra/CapriCapri	Carnival
3x3 - Paso 7	3x3 - Paso 7	3x3 - Paso 5	Todos los tamaños Paso 5	3x3 - Paso 6
3x4.25 - Paso 6	3x4.25 - Paso 9	3x4.25 - Paso 7		3x4.25 - Paso 5
3x5.46 - Paso 9	3x5.46 - Paso 9	3x5.46 - Paso 7		-
4x4.25 - Paso 12	-	-		-

* Para **fijar a la pared**, retorne al **paso 2**.

Paso 3: Conecte la parte **8303 (dibujos a y b)**, luego refiérase al manual de ensamble de la cubierta de patio como se indica a continuación:

Feria	Tuscany	Olympia	Sierra/Capri	Carnival
3x3 - Paso 8	3x3 - Paso 8	3x3 - Paso 6	2.3x2.3 - Paso 7	3x3 - Paso 10
3x4.25 - Paso 13	3x4.25 - Paso 13	3x4.25 - Paso 11	3x3 - Paso 6	3x4.25 - Paso 9
3x5.46 - Paso 13	3x5.46 - Paso 13	3x5.46 - Paso 11	3x4.25 - Paso 9	-
4x4.25 - Paso 16	-	-	3x5.46 - Paso 9	-

* Al terminar, en este paso realice lo que se indica en el **dibujo c**.

Paso 4: Puede elegir cualquiera de las 2 opciones de montaje a continuación, para todos los tamaños de cubiertas de patio que corresponda.

Opción 1 (Pasos 4+5+6+9+10+11+12) - montaje de todos los pilares suministrados.

Opción 2 (Pasos 4+7+8+9+10+11+12) - Siempre que esté utilizando este Kit EZ Link puede prescindir de usar una de las patas.







Paso 6: (**Opción 1**): asegúrese de que la distancia entre el poste y el punto de conexión no exceda los 60 cm / 23,6 pulgadas. La distancia máxima entre los postes no debe exceder los 120 cm / 47,2 pulgadas.

Paso 10: antes de realizar esta paso, consulte el manual de montaje de la cubierta de patio en la etapa de “**montaje del sistema de techo**” como se indica a continuación:

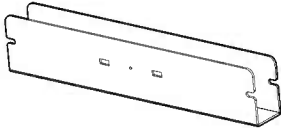
Feria	Tuscany	Olympia	Sierra/Capri	Carnival
3x3 - Paso 15	3x3 - Paso 14	3x3 - Paso 11	2.3x2.3 - Paso 12	3x3 - Paso 18
3x4.25 - Paso 22	3x4.25 - Paso 20	3x4.25 - Paso 17	3x3 - Paso 11	3x4.25 - Paso 16
3x5.46 - Paso 21	3x5.46 - Paso 20	3x5.46 - Paso 17	3x4.25 - Paso 15	-
4x4.25 - Paso 26	-	-	3x5.46 - Paso 15	-

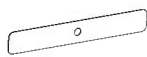
Paso 12: El ajuste de los pernos se hace desde la parte interior. Esparza silicona luego de la conexión (a y b).

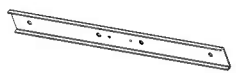
Contents

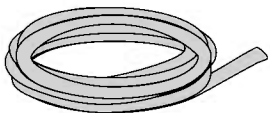
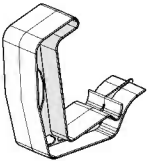
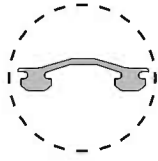
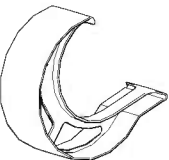
Item		Qty.	Item		Qty.
8192		9 (+1)	7431		1
461		4 (+1)	8303		1
466		13 (+1)	7039		2
7335		1 (+1)	7440		1
8119		1			
	OR				
7999		1			

1



7039

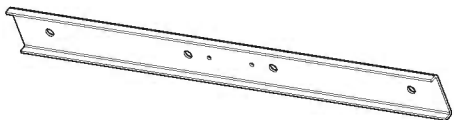

1

7335



1

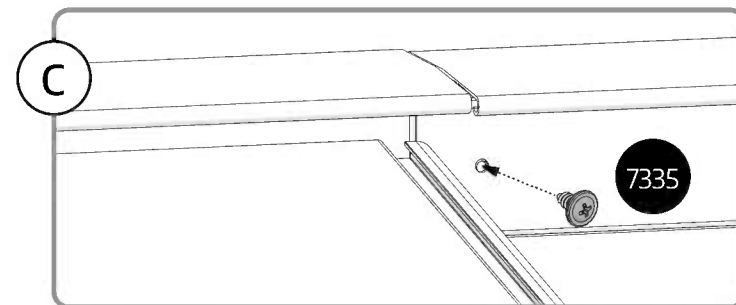
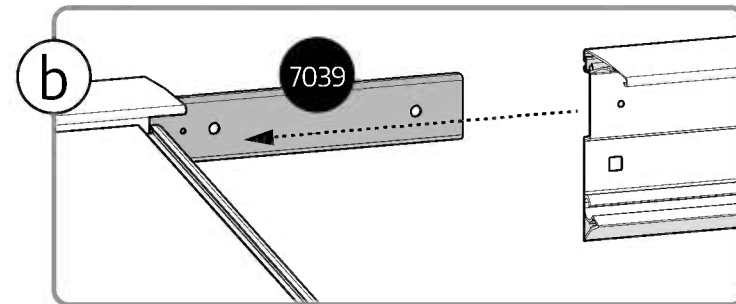
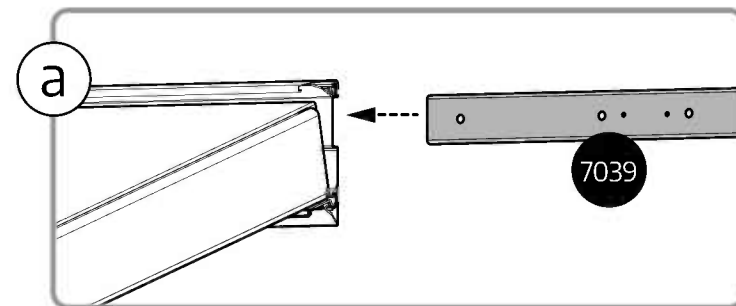
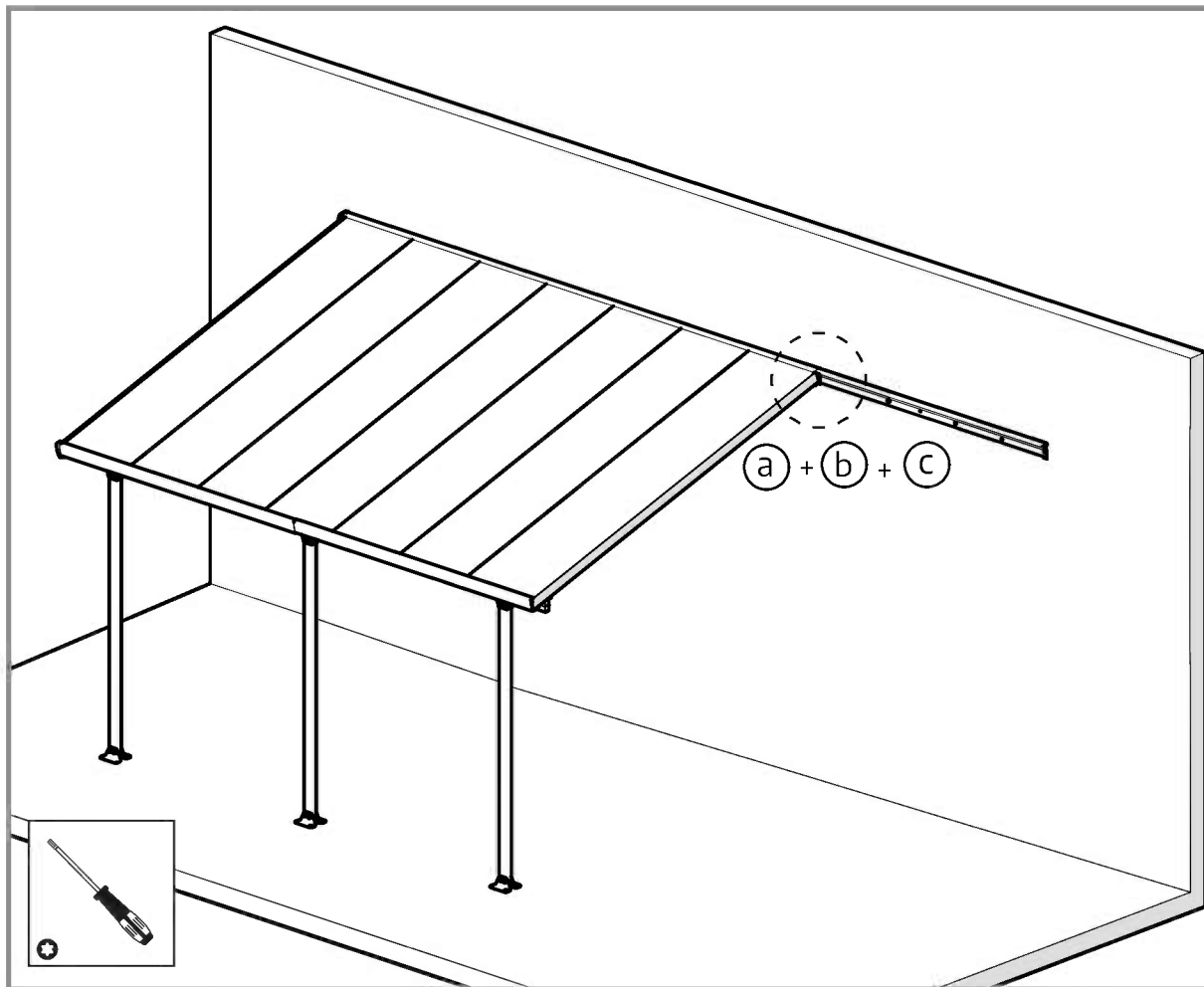

8303



1

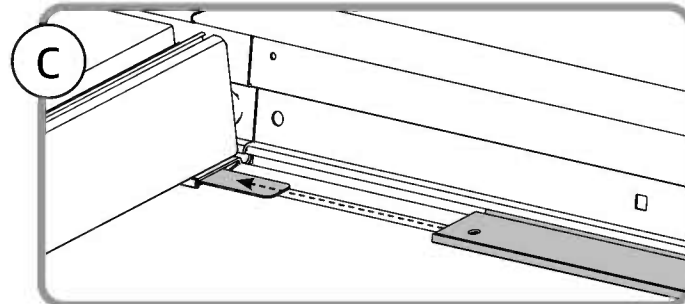
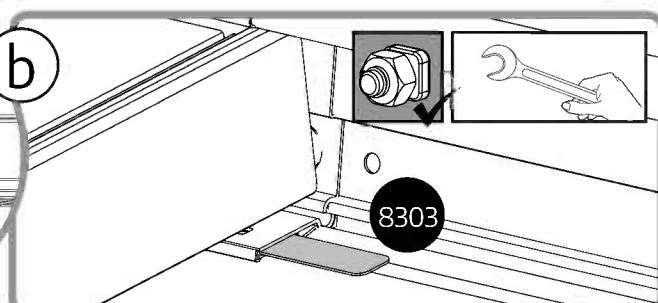
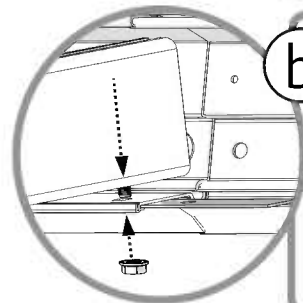
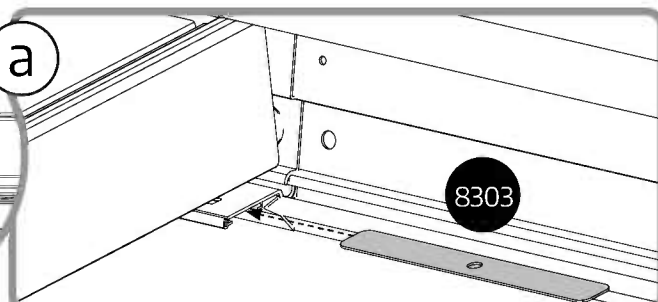
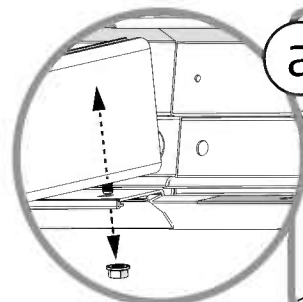
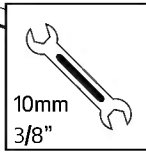
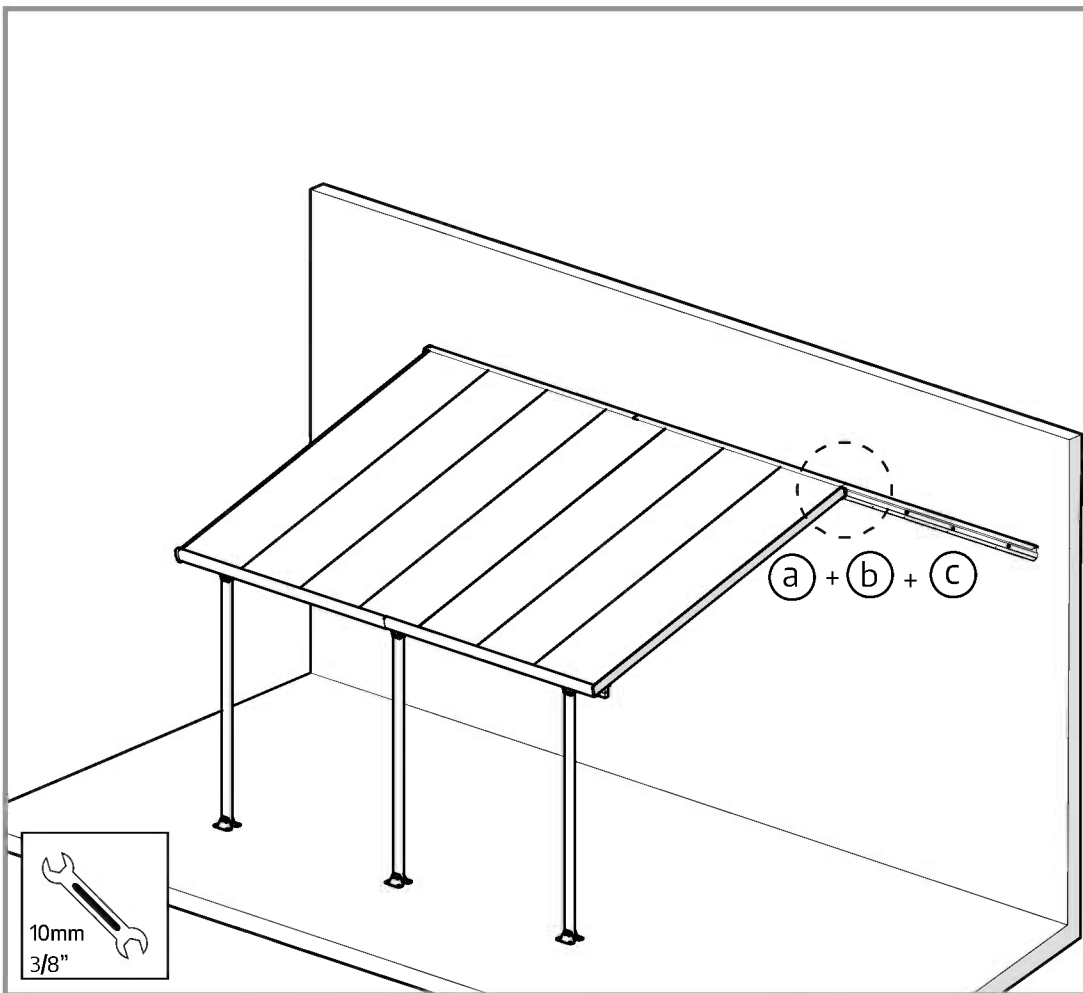



Option 1

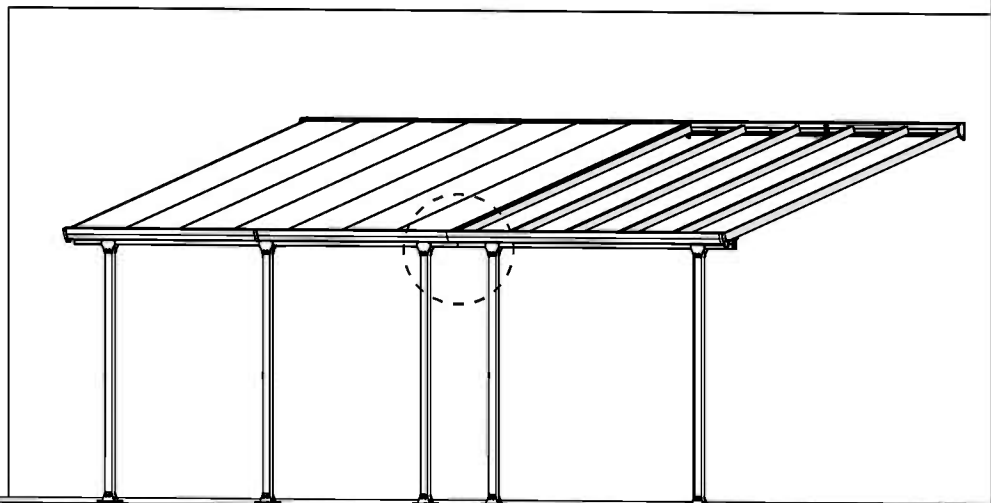
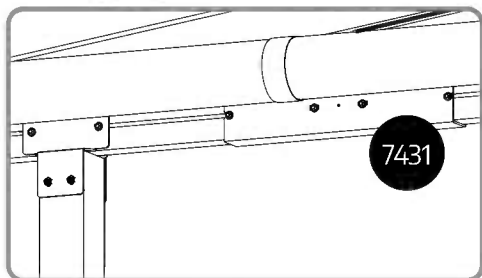
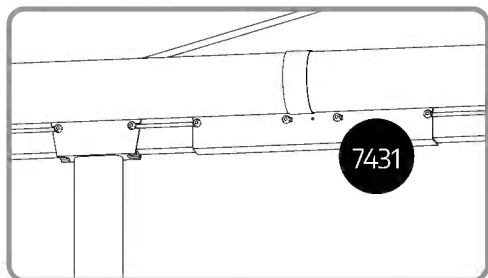
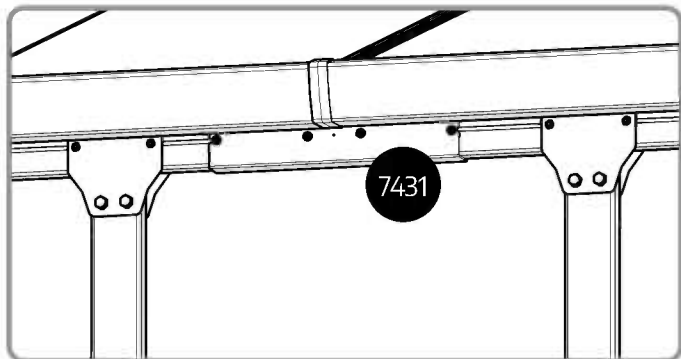

OR

Option 2

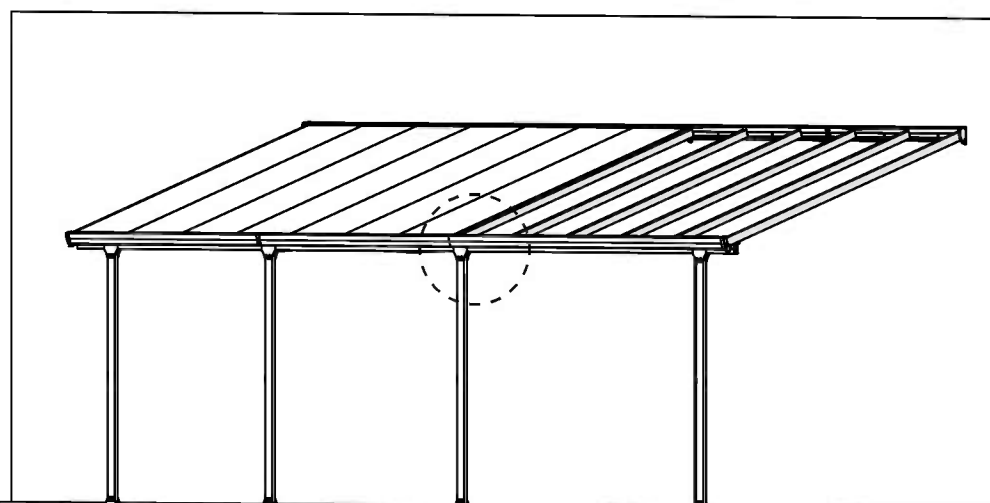
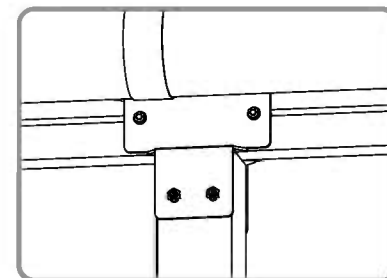
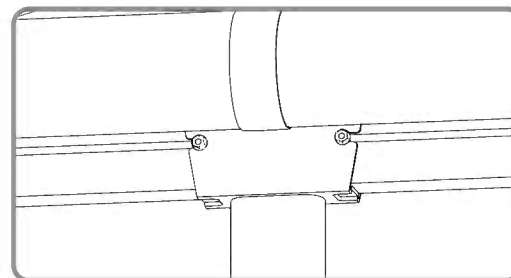
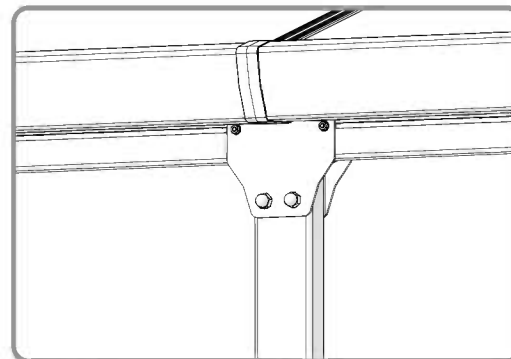

4 Option 1

8192 4



4

466 4



4

7431 1

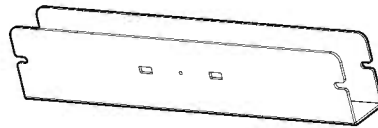

1

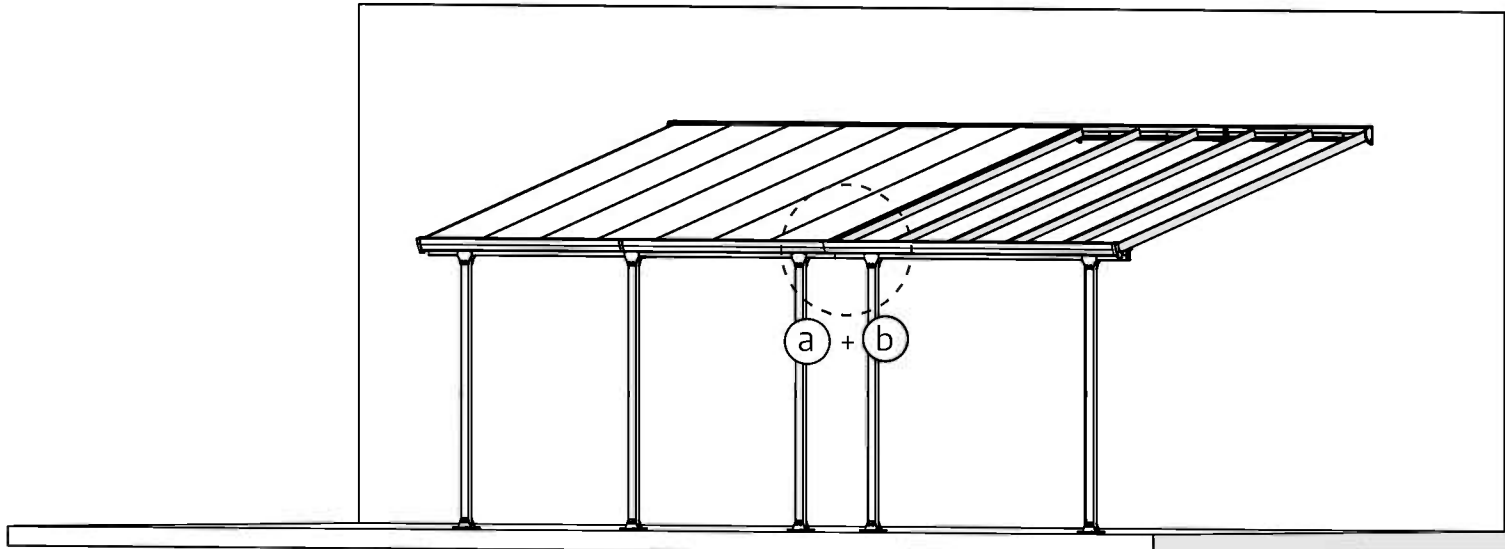
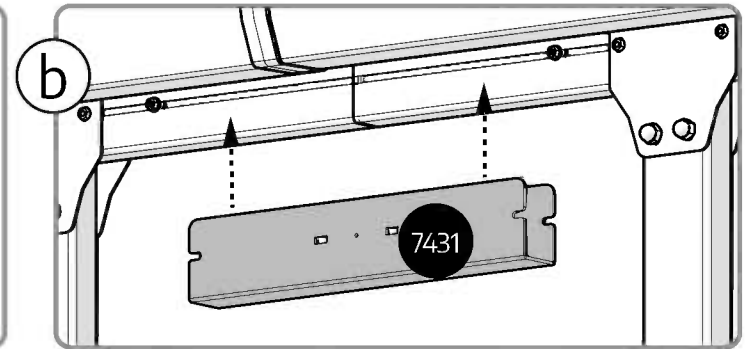
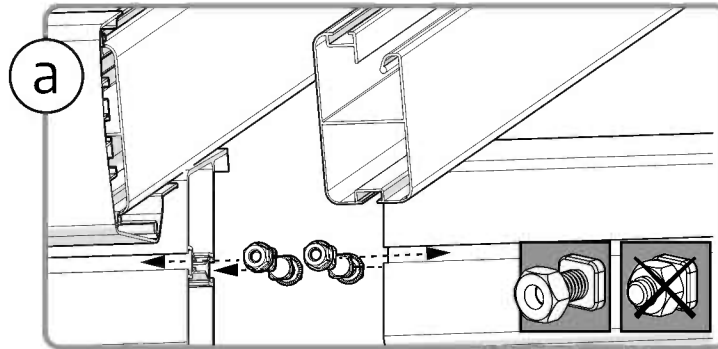

5 **i** Option 1

461 -----  ----- 4

466 -----  ----- 4

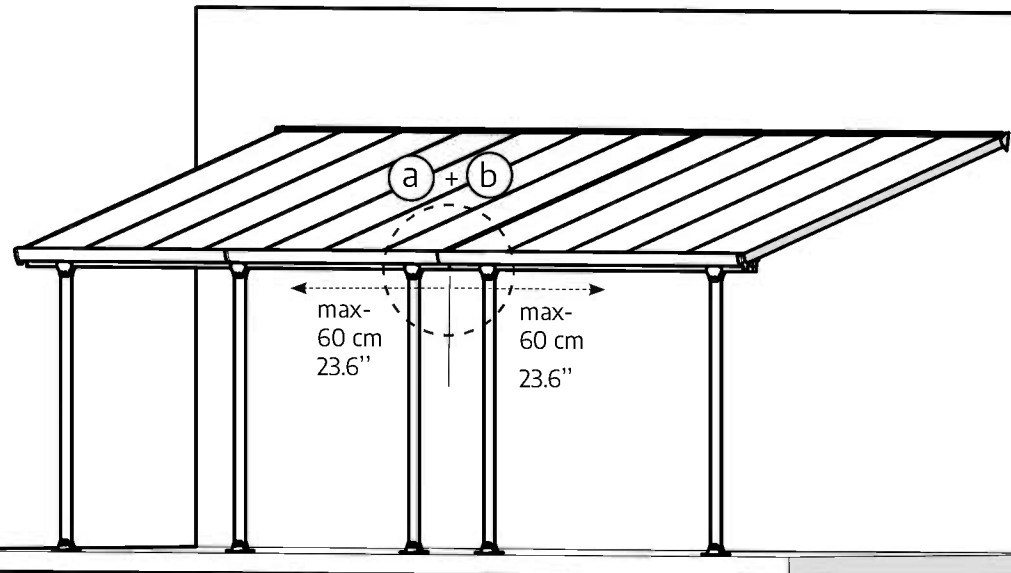
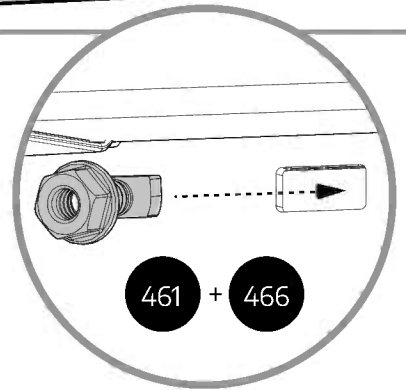
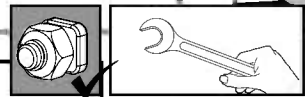
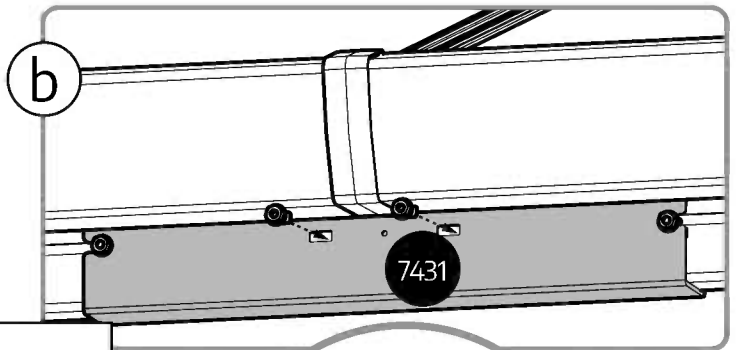
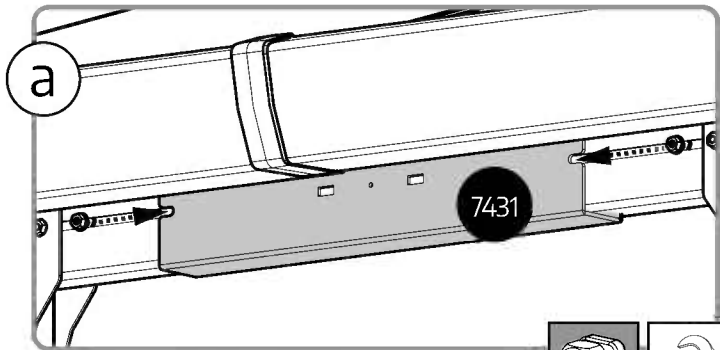

6 Option 2

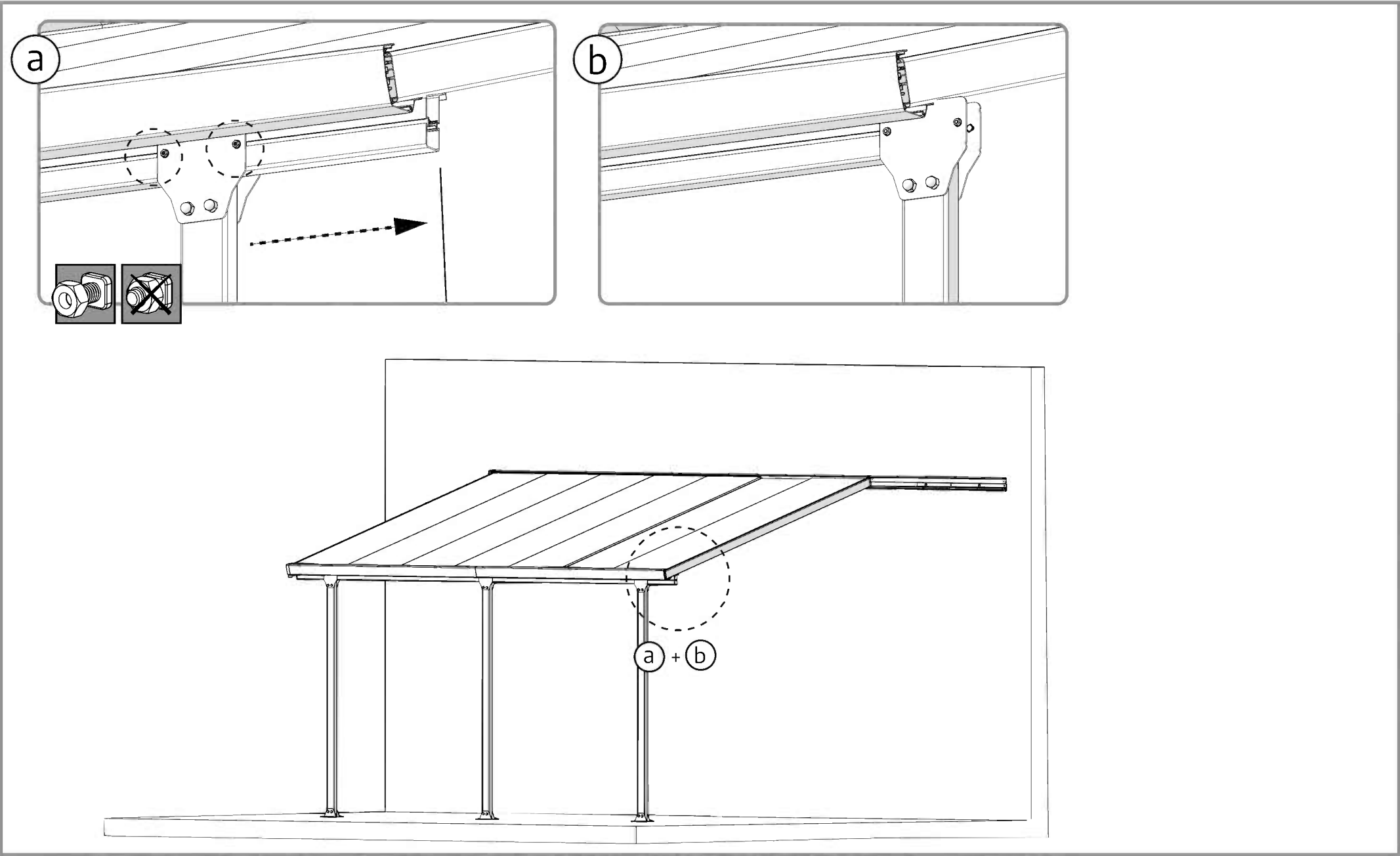

7 Option 2

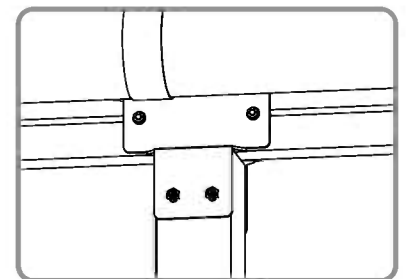
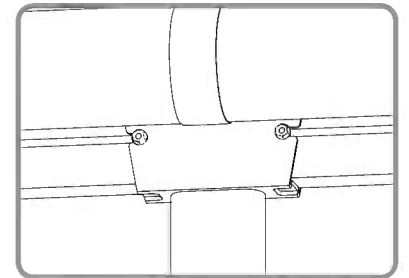
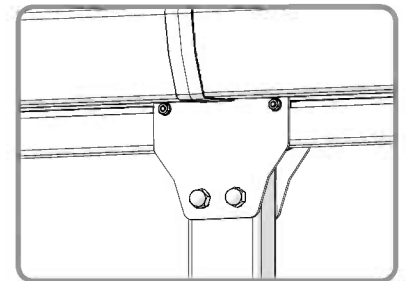
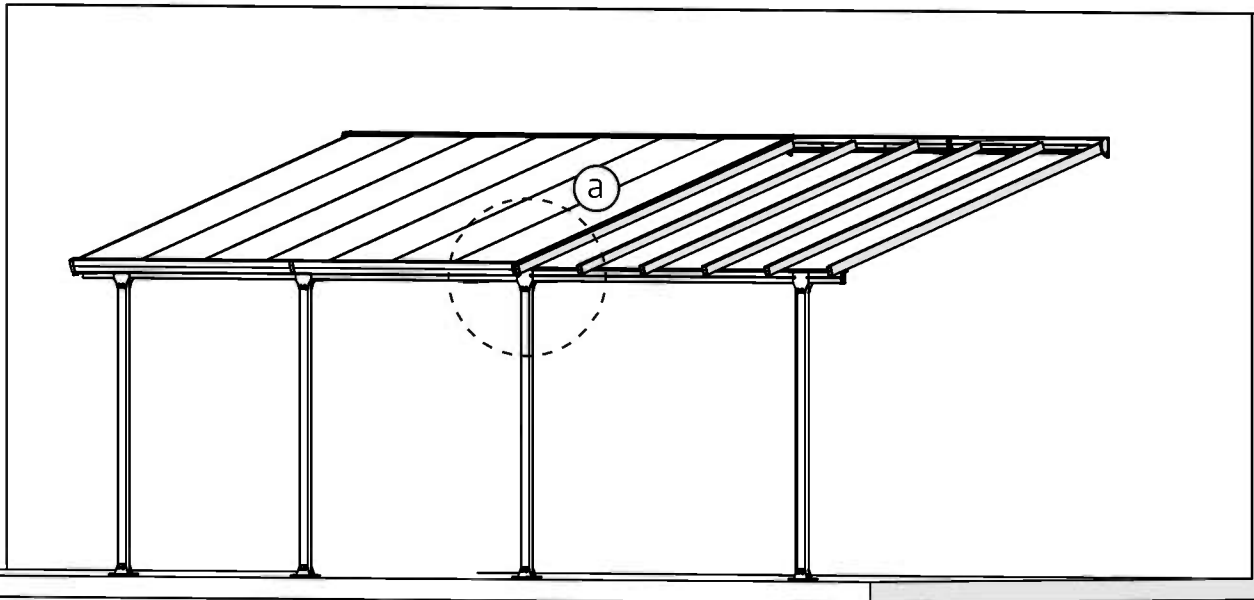
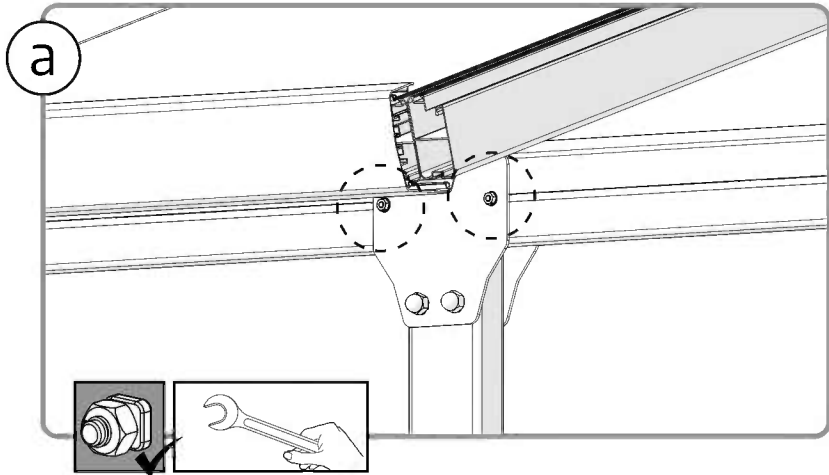

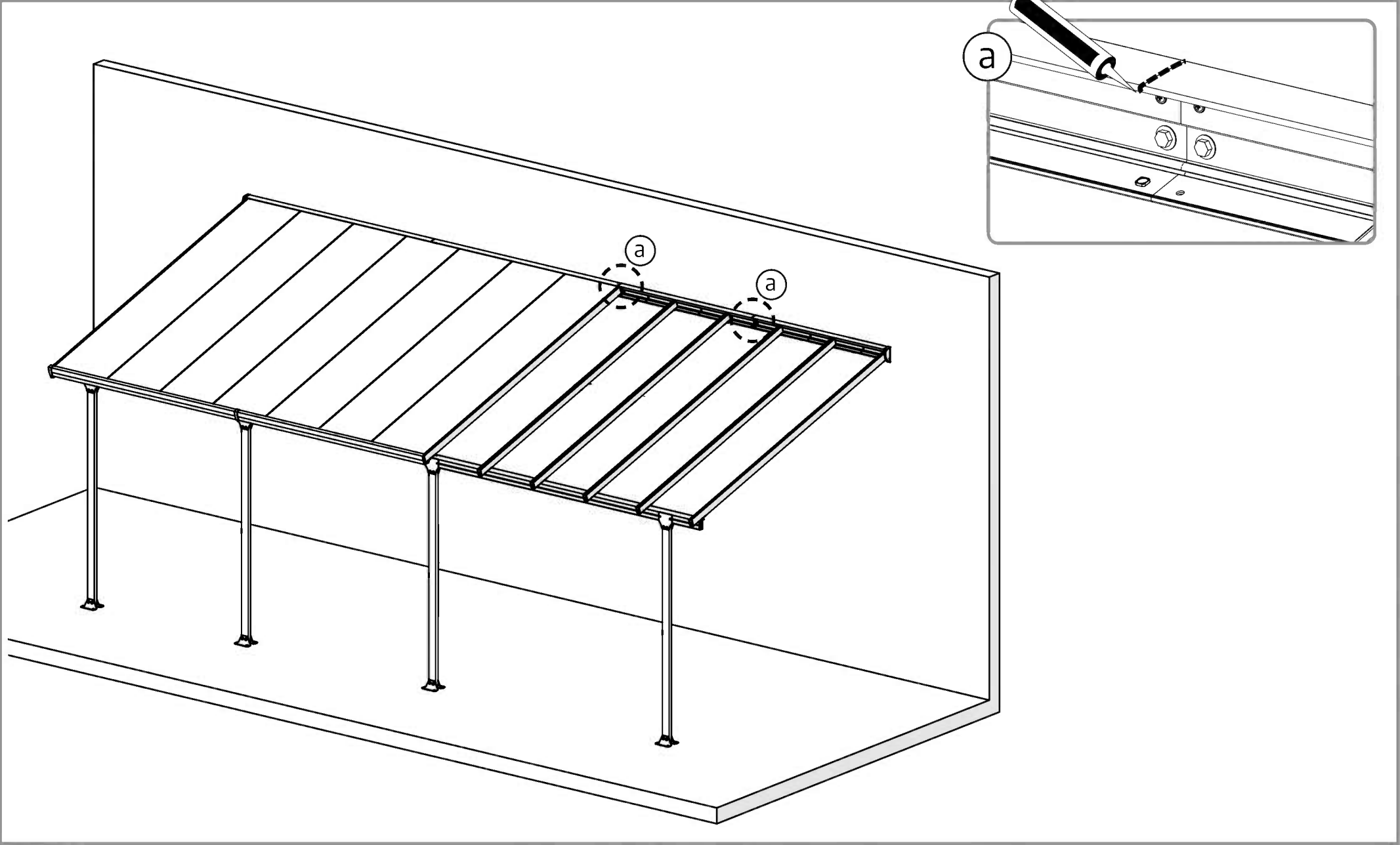

9



Options 1+2

7440

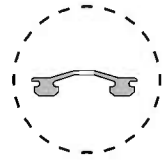
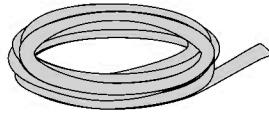

1

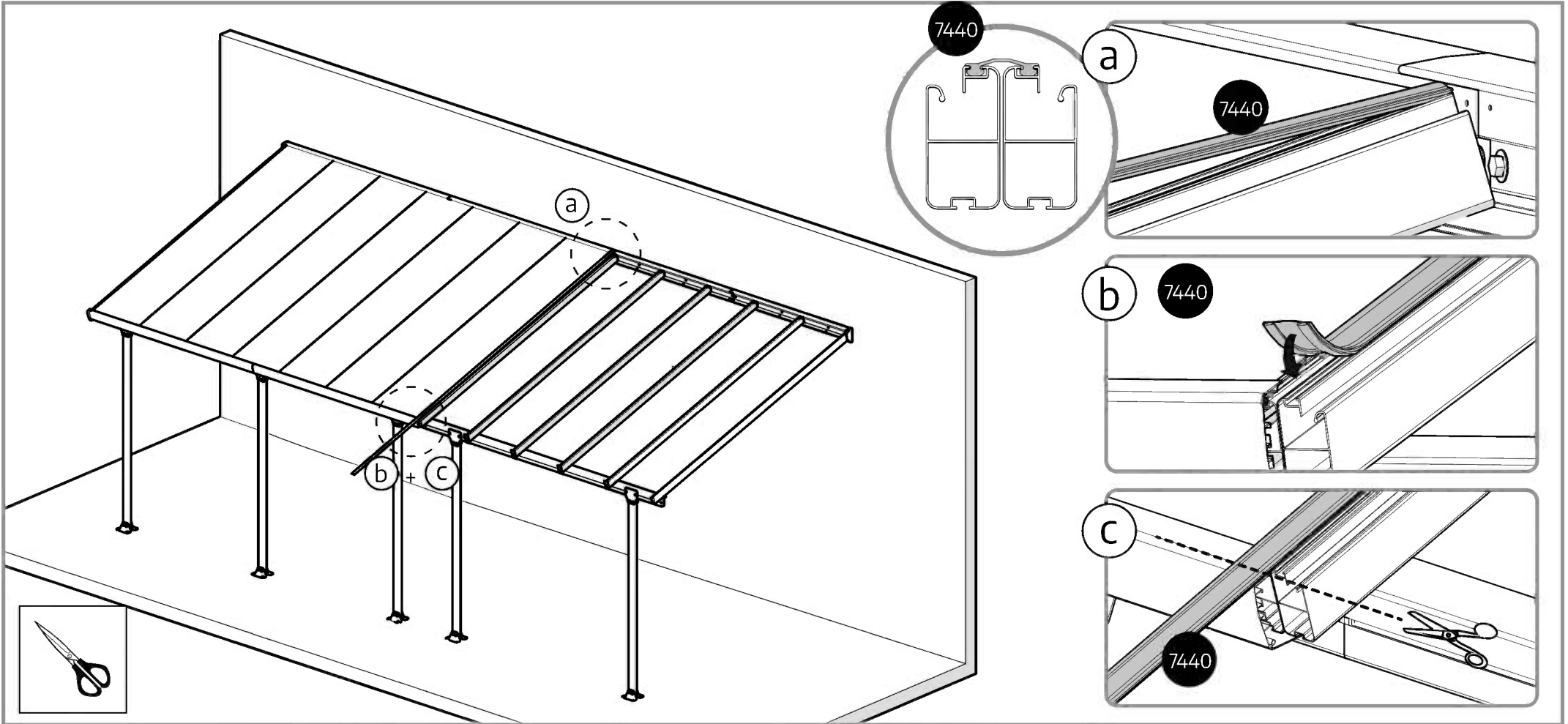

10 Options 1+2

