



## Monocrystalline Solar Panel

### User Manual

90/100 Watt



165/180 Watt



330Watt Kit

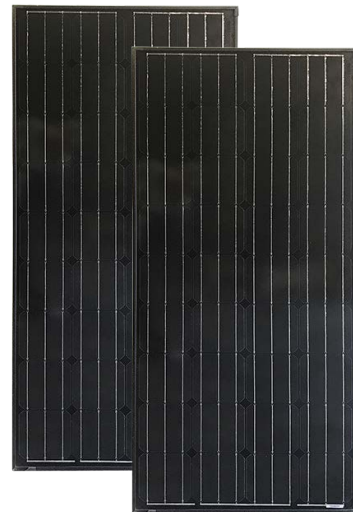

**⚠ WARNING:** Read carefully and understand all ASSEMBLY AND OPERATION INSTRUCTIONS before operating. Failure to follow the safety rules and other basic safety precautions may result in serious personal injury.

**SAVE THESE INSTRUCTIONS**

## Important Safety Information

Thank you for choosing a Nature Power Product.

Save the receipt and these instructions. It is important that you read the entire manual to become familiar with this product before you begin using it.

This product is designed for certain applications only. The distributor cannot be responsible for issues arising from modification. We strongly recommend this product not be modified and/or used for any application other than that for which it was designed. If you have any question relative to a particular application, Do not use the product until you have first contacted the distributor to determine if it can or should be performed on the product.

For technical question please call 1800-588-0590

### **WARNING**

- Read and understand all instructions. Failure to follow all instructions may result in serious injury or property damage.
- The warnings, cautions, and instructions in this manual cannot cover all possible conditions or situations that could occur. Exercise common sense and caution when using this tool. Always be aware of the environment and ensure that the tool is used in a safe and responsible manner.
- Do not allow persons to operate or assemble the product until they have read this manual and have developed a thorough understanding of how it works.
- Do not modify this product in any way. Unauthorized modification may impair the function and/or safety and could affect the life of the product. There are specific applications for which the product was designed.
- Use the right tool for the job. DO NOT attempt to force small equipment to do the work of larger industrial equipment. There are certain applications for which this equipment was designed. It will be a safer experience and do the job better at the capacity for which it was intended. DO NOT use this equipment for a purpose for which it was not intended.
- Industrial or commercial applications must follow OSHA requirements.



#### **WARNING**

This product can expose you to chemicals, including Di (2-ethylhexyl) phthalate (DEHP) which is known to the State of California to cause cancer, birth defects or other reproductive harm. For more information, go to [www.p65warnings.ca.gov](http://www.p65warnings.ca.gov)



#### **ADVERTENCIA**

Este producto puede exponerlo a productos químicos, incluidos Di (2-etilhexil) ftalato (DEHP) que el estado de California sabe que causa cáncer, defectos de nacimiento u otros daños reproductivos. Para obtener más información, vaya a [www.p65warnings.ca.gov](http://www.p65warnings.ca.gov)

## Cautions

- Never touch the end of output cables with your bare hands when the modules are irradiated. Handle wires with rubber-gloved hands to avoid electric shock
- Do not wear metallic jewelry when working on electrical equipment
- Product should be installed and maintained by qualified personnel
- Do not drop tools or other items on the glass of the solar module
- Do not scratch the back film of the solar panel
- Avoid exposing solar panels to partial sunlight or shadows. Partial sunlight can cause hot spots on the panel
- Do not pour chemicals on module when cleaning. To clean use a damp cloth do not apply excessive pressure to the cells
- Do not expose solar module to sunlight concentrated with mirrors, lenses or similar means
- Keep module away from children

### **Precautions when working with batteries**

- Never smoke or allow a spark or flame near the batteries
- Batteries generate hydrogen and oxygen during charging resulting in evolution of explosive gas mixture. Care should be taken to ventilate the battery area and follow the battery manufacturer's recommendations
- Batteries contain very corrosive diluted acid as electrolyte. Precautions should be taken to prevent contact with skin, eyes or clothing
- Use caution to reduce the risk of dropping a metal tool on the battery. It could spark or short circuit the battery or other electrical parts and could cause an explosion
- Remove metal items like rings, bracelets and watches when working with batteries. The batteries can produce a short circuit current high enough to weld a ring or the like to metal and thus cause a severe burn
- If you need to remove a battery, always remove the ground terminal from the battery first. Make sure that all the accessories are off so that you do not cause a spark
- Only use rechargeable 12 Volt batteries, ie. Sealed Lead Acid, Deep Cycle, Gel-Cell etc.
- Use properly insulated tools only when making battery connections
- When working with batteries please follow the battery's manufacturer manual and precautions

### **Precautions when working with solar panels**

With the incidence of sunlight or other light sources on all solar panels, a voltage appears at the output terminals of the solar panel turning it into a source of electricity. Do not make contact with the terminals when the panel is exposed to sunlight or other light sources. To avoid shock hazard make sure the solar panel is either turned over so the cells are not exposed to light or cover the cells with an opaque (dark) material such as paper/cloth during the installation process.

**WARNING: Ensure that the positive matches the positive and the negative matches the negative. ( Connections are in Parallel) Wrong connection may cause sparks and void the warranty.**

## Parts List

Reference	Part Description	Quantity
1	Solar panel with SAE connector wiring	1
2	SAE-Battery clamp cable	1
3	Mounting Z bracket set	4

## Technical Specifications

Rated electrical characteristics are within +10 percent of the indicated values of Isc, Voe, Pmax under Standard Test Conditions (irradiance of 100 mW/cm<sup>2</sup>, AM 1.5 spectrum, and a cell temperature of 25 °C {77°F}). The electrical characteristics are based on the results of outgoing test.

Pmax	90W	100W	165W	180W	330W(
Voltage at Pmax (Vmp)	17.5V	17.5V	17.5V	17.5V	*kit consists of 2 165W panels*
Current at Pmax (Imp)	5.14A	5.71A	9.43A	10.3A	
Open Circuit Voltage (Voc)	21.6V	21.6V	21.0V	21.0V	
Short Circuit Current (Isc)	5.49A	5.49A	9.95A	9.95A	
Dimension	32.6x26.5x1.2"	32.6x26.5x1.2"	57.8x26.5x1.4"	57.8x26.5x1.4"	
Efficiency	18.2%	19.85%	17.20%	18.9%	
Cell technology	Monocrystalline				
Class	A				
Weight	21.1lbs	21.1lbs	25.3lbs	25.3lbs	

## Installation

1. Open the packaging and check to make sure that all parts have been received.
2. Arrange to have on hand the proper tools to carry out the mounting installation.
3. Determine the mounting location of the solar panel(s). It is important the solar panel receive the maximum amount of sunlight during the day and not be shaded.
4. Connecting solar panel to battery for 12V charging.
5. Mount the charge controller within 5 feet of battery or loss of current may occur.
6. Wire the battery to the charge controller and then the solar panel to the charge controller to ensure that the correct polarity is observed.
7. Secure the solar panel to the desired location, solar panel must be within 20 feet of the battery, or loss of current may occur.

### Easy Electrical Installation

Please confirm that you have all parts to your system before starting installation. Figure 1 shows how to connect the solar panel to the 12 Volt batteries

#### Step 1

Connect the charge controller to the solar panel

#### Step 2

Connect the battery clamps to the charge controller

#### Step 3

Connect the battery clamps to the battery in parallel.  
(Parallel connections= Positive to Positive and Negative to Negative)

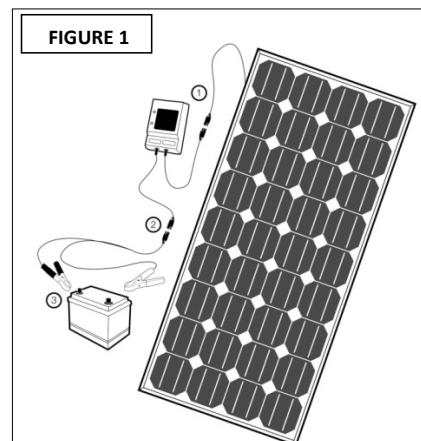

When installing solar panels configuration and systems, please carefully observe correct cable connections and polarity. The solar panels can be damaged by not observing the correct electrical installation and polarity; in addition, this will void the warranty of your solar panel(s). Having a multi-meter handy will help to confirm correct polarities.

#### Extending the wiring

If you choose to mount your solar panel further away from the charge controller by extending the wiring we recommend the following gauges at each specified distance. Use stranded wire instead of solid wire. Stranded wire does not fatigue or loose connections over time.

**Appropriate wire gauge should be used for distance and total amperage, for further information please consult with a licensed electrician or through an online wiring chart calculator**

## Solar Panel Mounting

### Mounting the Solar panels

Choose a site for mounting the solar panels that is free from shade and located in an area that receives maximum sunlight daily. For maximum solar power absorption throughout the day, a tilt-mounting kit is recommended.

The solar panels can be permanently installed level using the Z-brackets.

Measure the distance between the mounting site and the battery location. The charge controller should be mounted in close proximity to the battery bank (within 5 feet). Refer to the DC electrical wire guide to choose an appropriate gauge wire for the length of the wire.

If you choose to mount your Solar Panel on your RV, be sure you solidly mount your panels to the roof. If you have a rubber roof over thin plywood you may want to use molly fasteners to get a better grip. If you have a fiberglass roof, drill some pilot holes through the fiberglass to reach plywood below. This will prevent cracking or damaging the fiberglass. If your RV is equipped with a metal roof you must mount the solar panel to the joists supporting the roof. Figure 3 shows an example of how the panel can be mounted with the z-brackets.

FIGURE 3

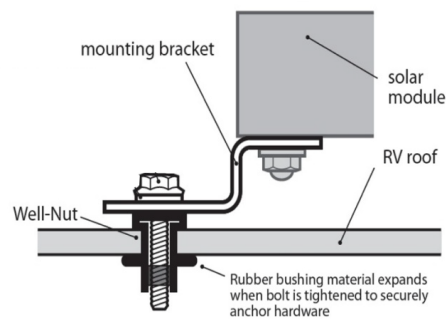

The wire from the solar panel can be routed to the interior of the RV through the roof-top refrigerator vent. In this kind of installation attempt to mount the panel near the refrigerator vent. See Figure 4.

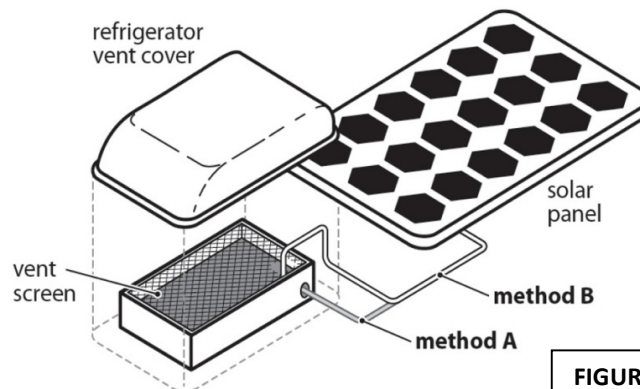

FIGURE 4

## Operating Instruction

### Additional Solar Panels

1. To connect 2 Solar Panels together simply remove the SAE connector at the end of each Solar Panel to reveal at least 2 inches of bare wiring.
2. Once the two wires are exposed they can be connected together by either twisting the wires together or by using solder. When connecting the wires always ensure the correct polarity is observed, Negative (- Black) to Negative and Positive(+ Red) to positive.
3. Once the wires are connected they can be placed in/on the correct terminals of your charge controller.
4. Once the wires have been placed on their terminals correctly ensure the connection is safe and secure and that the bare wires cannot come into contact with each other. This can be done by using insulation tape or electrical tape that can be wrapped around the wires to stop them from coming into contact with one another.

**Note:** If the Solar Panel wires short while being connected to the Charge Controller it may cause irreparable damage. Removing the SAE connector will not void the warranty on Solar Panels.

**You can also contact nature power for a 2 in 1 SAE cable for 2 panels fast connected.**

### Selecting the correct Battery

We do not offer batteries. However, please choose a 12 Volt rechargeable battery. Do not attempt to recharge non-rechargeable batteries. 6 Volt battery configurations may also be used if connected in series (Negative to Positive). You may choose a Sealed Lead Acid battery, a Gel-Cell or a Deep Cycle 12 Volt battery. Batteries come in all different sizes, Please converse with your battery dealer for more information on which type of battery you should use for your system. Note your solar panel amperage rating when selecting your battery size.

### Additional 12V DC Batteries

Addition batteries may be desired for extra electrical storage.

For 12 Volt battery bank configurations; make sure your batteries are connected in parallel (Positive to Positive and Negative to Negative)

- From the charge controller attach the red battery clamp to the red terminal of the first battery in the bank, matching the polarities, positive to positive.
- Then connect the black alligator clamp to the black terminal of the second or last battery in the bank, again matching polarities, negative to negative. This will ensure an equal charging across both or all batteries.

### Selecting the Correct Charge Controller

Charge Controllers may be sold separately and are required for installations of solar systems arrays that are rated 12 Watts and higher. Charge Controllers help to protect the battery(s) and solar panel(s) from harmful reverse currents, battery over charging and high wattage surges, additional protections are found on larger charge controllers.

If two or more solar panels are connected in series/parallel make sure that the sum of the short circuit current ratings of all panel strings does not exceed 80% of the charge controller's current rating i.e. 8 Amps or 28 Amps.

### 8 Amp Charge Controller

is an easy to connect and easy to read charge controller with LED light indicators for battery charging cut-in voltage 13V and battery full cut out voltage 14.2V. The 8 Amp Charge Controller is compatible with solar system arrays rated up to 130 Watts.

Protections:

- Reverse Current
- Over Charge
- Low Voltage
- High Voltage surges

### 28 Amp Digital PWM Charge Controller

With Pulse Width Modulation (PWM) technology this charge controller helps to maintain a higher charging efficiency, thus maintaining a higher battery reserve and capacity than the standard on-off 8 Amp charge controller. The 28 Amp Digital PWM Charge Controller features a digital LCD display and adjustable voltage settings.

Protections:

- Short Circuit
- Low Voltage
- Overloading
- Discharging
- Reverse Current
- Discharging

### Connecting an Inverter

An inverter can be used to converting the 12 Volt energy created to 120 Volt Electricity.

Inverter sizes and types vary depending on your power consumption needs. Please discuss which inverter to purchase with your Inverter dealer.



## Run Times

Please refer to the run times chart to choose how much solar power your desired system requires. Note that all run times and ratings are approximate and may vary depending on your location and time of day and are based on 7 Hours of full sunlight a day.

Rated Hourly (Maximum output)	90 Watt	100 Watt	165 Watt	180 Watt	330 Watt
	5.14 Amp	5.71 Amp	9.43 Amp	10.28 Amp	18.86 Amp
Weekly Output	4410 Watts/ 251.86 Amps	4900 Watts/ 279.79 Amps	8085 Watts/ 462 Amps	8820 Watts/ 501 Amps	16170 Watts/ 924.14 Amps
<b>Weekly Run Times</b>					
Laptop 20-50 watts	88 hr	98 hr	160 hr	176 hr	320 hr
PC 80-150 watts	29 hr	32 hr	50 hr	59 hr	100 hr
Television 19" Color 70 watts	63 hr	70 hr	110 hr	126 hr	220 hr
CD Player Radio 35 watts	126 hr	140 hr	230 hr	252 hr	460 hr
Fan 10-50 watts	83 hr	98 hr	165 hr	176 hr	330 hr
Halogen Light 100 watts	44 hr	49 hr	80 hr	88 hr	160 hr
Fluorescent Light 40 watts	110 hr	122 hr	200 hr	220 hr	400 hr
Coffee Maker 800 watts	6 hr	6 hr	10 hr	11 hr	20 hr
Portable Heater 1500 watts	3 hr	3 hr	5 hr	6 hr	10 hr

## Maintenance

### Monitoring your Solar System

To confirm your solar panels are generating power we suggest purchasing a multi-meter. Annual testing and inspections are recommended to confirm all connections are secure and panels are functioning properly.

Open voltage testing of solar panels may range from 11 Volts up to 21.6 Volts depending on the intensity of the sun, this is within normal range.

Upon annual inspections it is recommended to wipe all solar panels with a damp towel to remove dust and debris covering the panels, as layers of dust can affect the solar panel voltage.

### Routine Maintenance Check List

- Check and replace damaged components if necessary
- Clean with a damp towel or cloth remove all debris
- Check and maintain the battery electrolyte levels are at regular intervals as per the battery manufacturer's recommendations if flooded wet cell lead acid batteries are used
- Check solar panel open voltage range
- Check solar panel close circuit range
- Confirm all wiring connections are secure and tight
- Confirm all mounting connections are secure and tight

## Limited Warranty

Nature Power warrants our products to the original purchaser that this product is free from defects in materials and workmanship for the period of 1 year from date of purchase, 25 year warranted to generate up to 80% of rated power from date of purchase. In the case of product defect, contact Nature Power customer service to receive troubleshooting. If defective part or unit should be returned, a Return Authorization Number must be issued by Nature Power and the defective part or unit should be returned to the authorized location at the purchasers' expense. A dated proof of purchase is required to receive warranty service. Once received at authorized location and defect proves to be the result of defective material and workmanship, the defective part or unit will be replaced at warrantors' option and returned to the original purchaser at warrantors' expense. No refunds will be granted by the warrantor, in the event of buyer's remorse please contact your point of purchase within and in adherence to their return policy. Refunds are granted at the retailers' discretions.



**Please contact Nature Power Products to acquire more information:**

1-800-588-0590

[info@naturepowerproducts.com](mailto:info@naturepowerproducts.com)

[www.naturepowerproducts.com](http://www.naturepowerproducts.com)

Made in Vietnam