

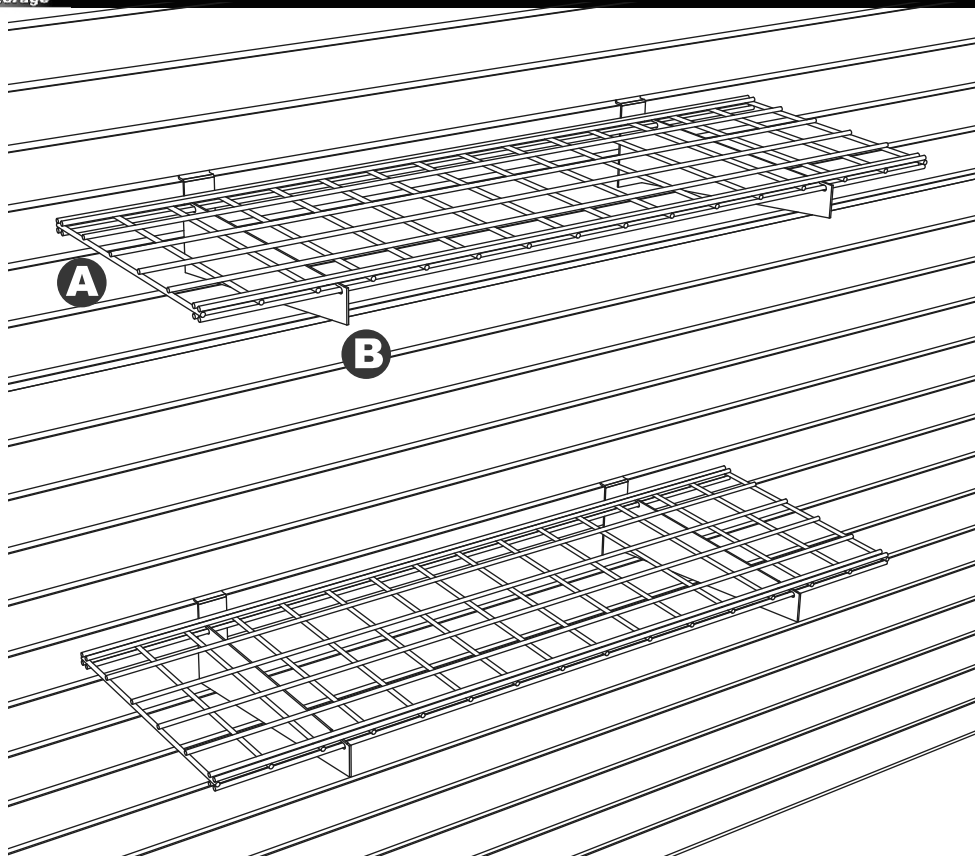

# ASSEMBLY INSTRUCTIONS

45" x 15" 2-SHELF SLATWALL STORAGE SYSTEM

Item # 291 & 292



### Parts Included:

Contains TWO complete shelves

**A** 2 Wire Grids

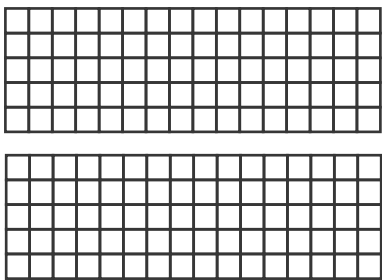

**B** 4 Shelf Brackets - 2 Lefts, and two rights

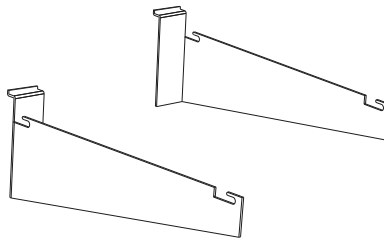

**C** 4 Rubber Stoppers

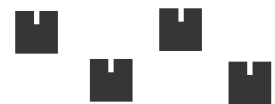

**D** HyLoft Sticker



## No Tools Required

MISSING A PART? There is no need to return this item to the store. Instead, call us Toll Free 800-441-4111

Approximate Assembly Time: 10 minutes or less



## INSTALL SHELF BRACKETS IN TO SLATWALL

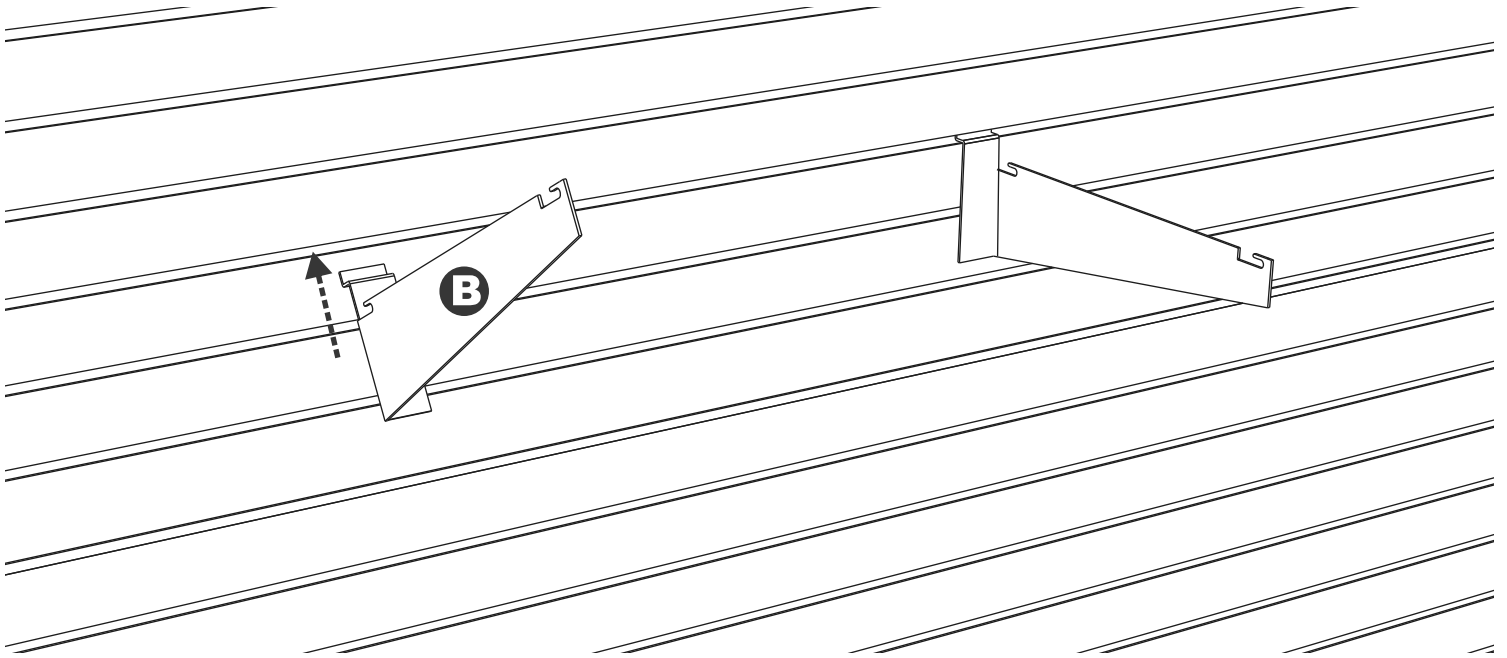

Insert Brackets (B) in to grooves in slatwall from 22" to 26" apart.



## PLACE AND ATTACH GRIDS

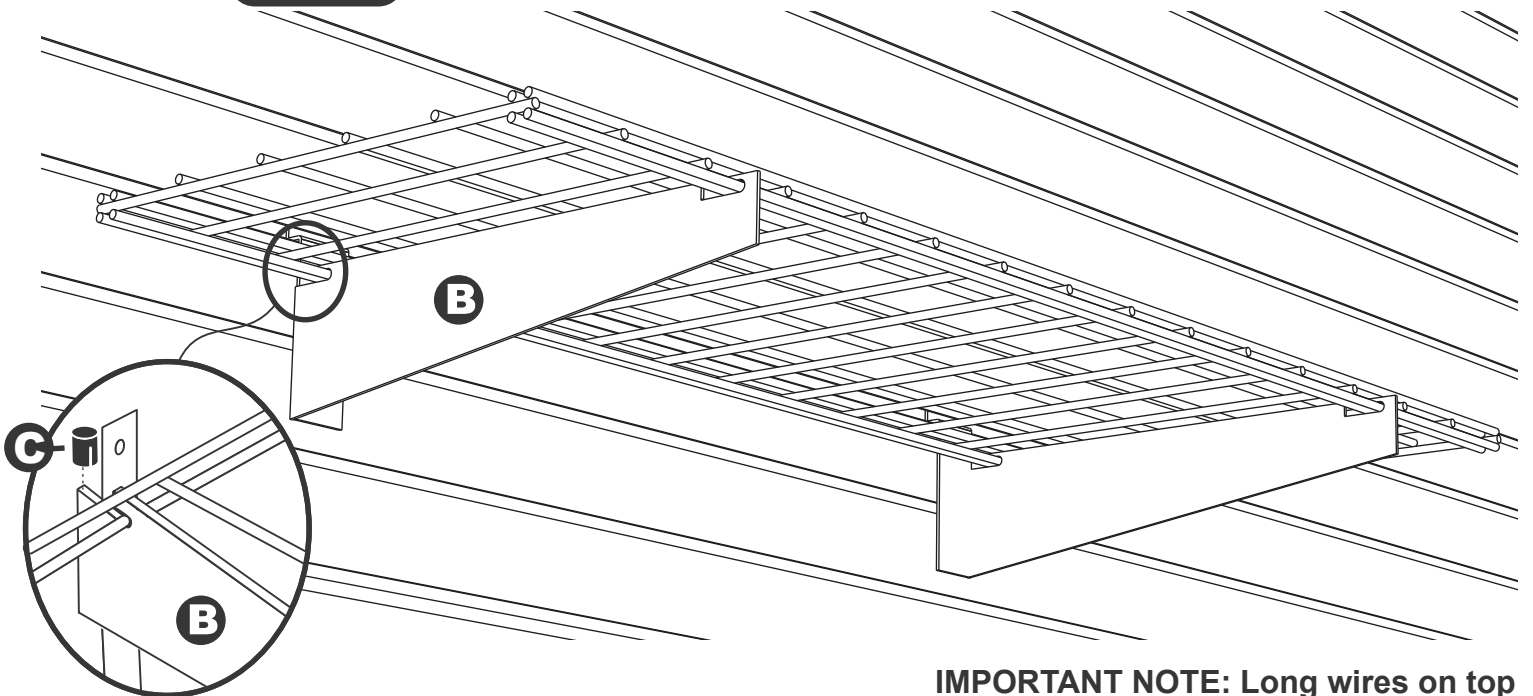

**IMPORTANT NOTE: Long wires on top**

Place Grids (A) on top of Brackets (B) and into slots with long wires on top. Pull shelf forward to lock in place.

Place slot in Rubber Stoppers on to Brackets (B) behind shelves.

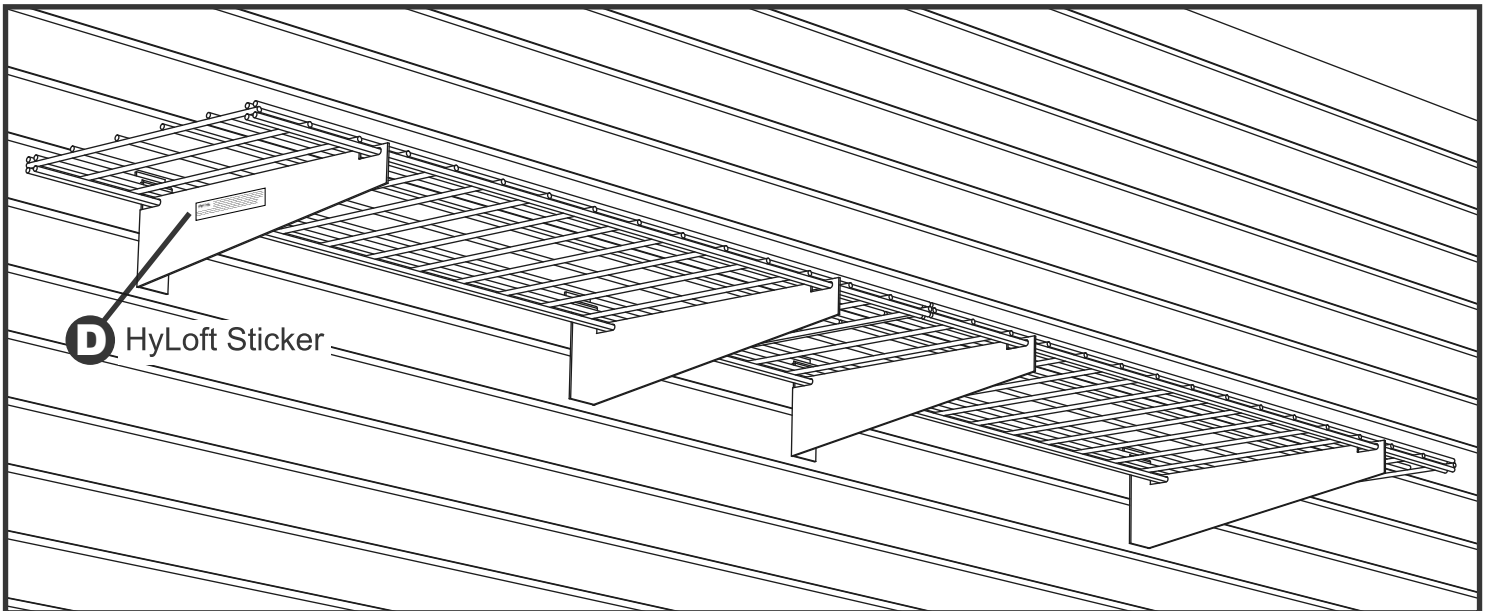
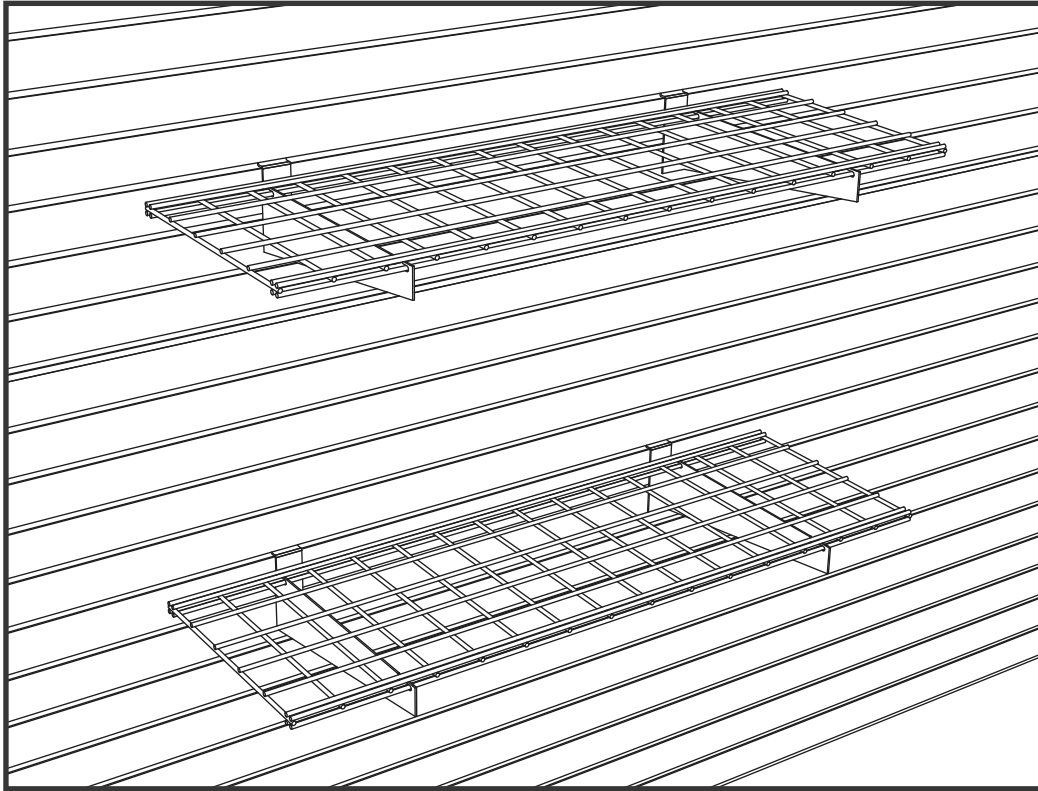

Use shelves side by side, one shelf above the other or anywhere you need storage!

You have now completed the installation and are ready to load your new HyLoft Shelf. **(Maximum 150 lbs per 15"x45" shelf, evenly distributed, as long as your slatwall manufacturer specifies this weight load is acceptable for the slatwall material. Please check with your slatwall manufacturer for recommended maximum weight load.)**

Place the sticker(D) provided on a bracket for convenient reference information.