

**eSenlite**

Model: **EEBPTL2450W-RC**, (option: **EEBPTL2235W-RC**; **EEBPTL1435W-RC**)

2-Pack



**6500 Lumens**

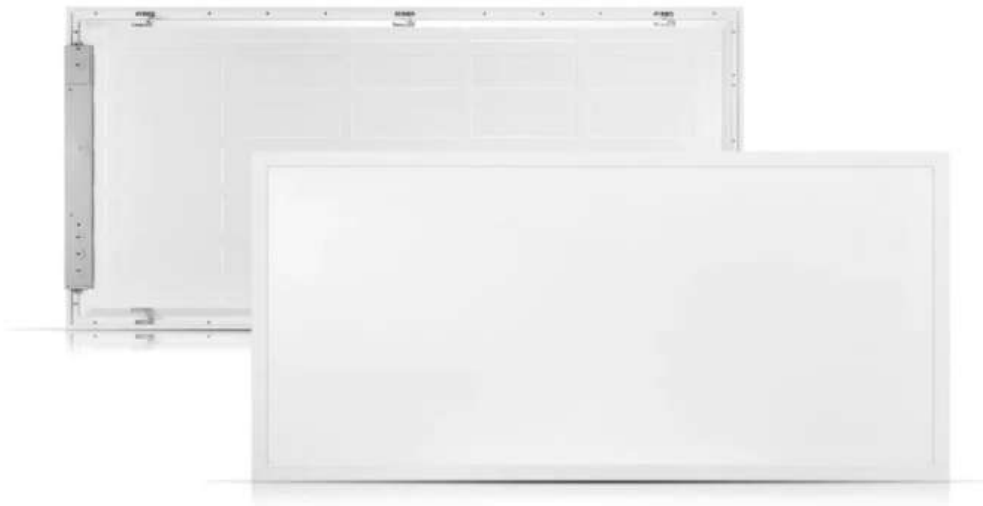

One Free Handheld Remote Included



**Product Name:** LED Drop Ceiling Flat Panel Troffer Light  
(dimmable, color selectable)

**Product model:** EEBPTL2450W-RC (EEBPTL2235W-RC; EEBPTL1435W-RC)

**Specifications:** 100-277VAC, 50/60Hz

**Version number:** Ver 1.1-102021

**Contact information:** [info@eesgi.com](mailto:info@eesgi.com)

1-877-579-3889 (M-F, 10am-5pm PST)

### 1. Overview:

LED Drop Ceiling Flat Backlit Panel Troffer Light is a kind of top-grade interior lighting products which is composed by a multiple of high-performance 3<sup>rd</sup> generation LEDs. Well-built innovative structure, side view emitting, high transmittance LGP, illumination uniformity and soft light that relieve eye fatigue. No radiation, it does not irritate the pregnant women, elderly and children's skin.

The light fixture design is simple and unique, luxurious atmosphere, with good lighting effects, and brings a feeling of beauty. It is a new, high-end stylish interior lighting.

### 2. Highlights & Features:

- Advanced LED driver designed, outstanding long lifespan up to 80,000 hours
- Instant light up, soft lighting profile, no glare, no noise, no strobe
- Simple, chic and elegant appearance, non-discoloring
- Lead-free and mercury-free, energy saving with environment friendly
- 2.4G wireless CCT remote control for user with friendly flexibility panel light, it's up to 100ft remote control coverage distance. Can be work with either of handled remote and/or North America standard wall mounted type remote controller
- Compatible with 0-10V dimmer with standard dimming function.

### 3. Product Certification:



### 4. Applications:

Mainly suitable for commercial, Industrial and residential lighting applications

Widely useful in Office Building, Schools/classroom, Studio, Library, Laboratory, Supermarkets, Meeting/conference room, Exhibition Hall, Working shop/room, Underground Garage, Warehouse and so on with high CRI.

**Photoelectric Parameter: EEBPTL2450W-RC** (EEBPTL2235W-RC; EEBPTL1435W-RC), Data by 25C temp

Parameter		Symbol	Min. Value	Typical Value	Max Value	Unit
Electricity Parameter	Input Volt	Vin	AC100~277			V
	Input Current	Iin	198~550, (140-385)			mA
	Input Frequency	F	50/60			Hz
	Power Load	P	50, (35W)			W
	PF	Pf	>0.9			-
	THD	THD	<15%			-
	Working Temperature	To	-20~+50			°C
	Working Humidity	Hop	23~70			%RH
	IP Grade	IP	IP40			-
	Shock Grade	Class	Class II			-
Light Parameter	LED Type	Model	2835			-
	LED Qty	Q	96x2 (48x2,56x2)			PCS
	CCT	Tc	3000-5000			K
	Emitting Color	Col	3000-5000K			
	Luminous Flux	φ	6500, (4550)			Lm
	Luminous Efficiency	Lm/W	130			Lm/W
	CRI	Ra	>80			-
	R9	R9	12			-

	Beam Angle	$\theta$	120, (130)	°
	Lux	E	235Lux/1 ft,	
Quality Guarantee	Lifespan	T	50,000	Hrs.
	Warranty	T	<b>5</b>	Years

## Instructure and Packaging

### 1. Dimension: 2’/24”x4’/48”x1.4” (or 1’/12”x4’/48”x1.4”; 2’/24”x2’/24”x1.4” option)

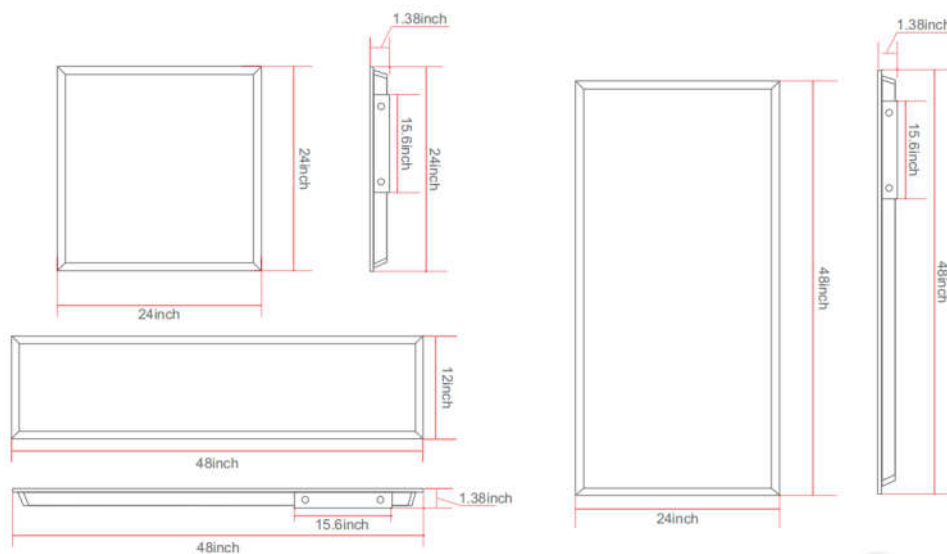

### 2. Packaging data (EEBPTL2450W-RC only):

Parameter	Value	Unit	Parameter	Value	Unit
Unit Size	<b>48x12x1.4</b>	INCH	Carton Size	<b>50x25.5x4</b>	INCH
N.W	<b>7.3</b>	LB/PC	Quantity	<b>2</b>	PCS
G.W	<b>8.4</b>	LB/CTN	Total W.	<b>21</b>	LB

### 3. Application Reference:



## Installation Instruction

### 1. Standard Embedded installation:

- ①. Remove the same size of ceiling tile or existing old light panel/fixture, refer 1

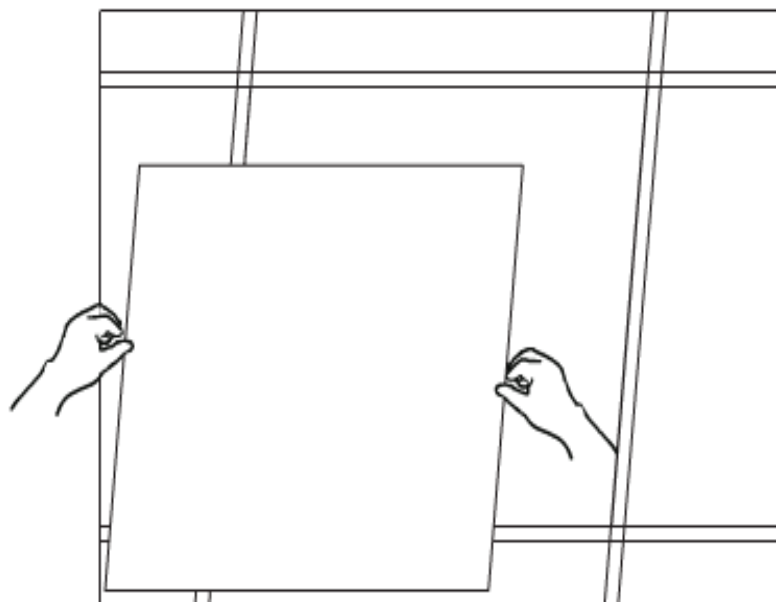

1

②. Connect AC power, refer 2

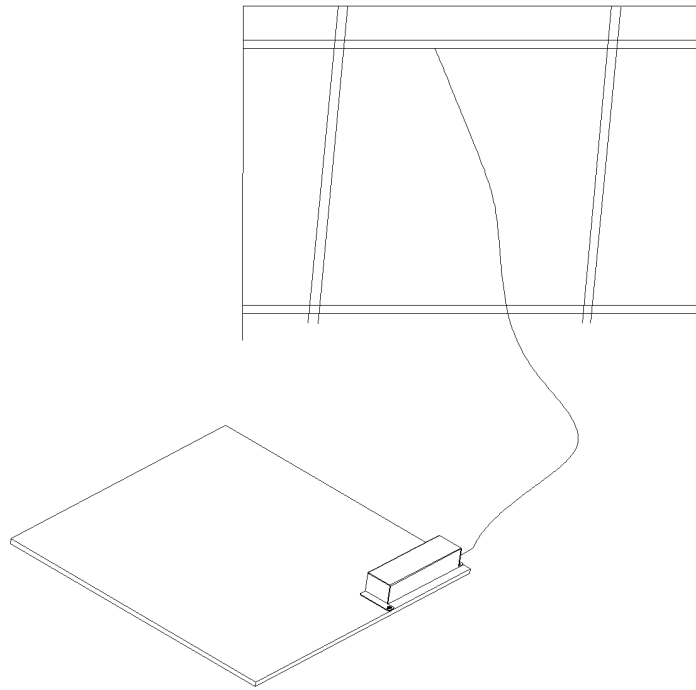

2

③. Put the light panel back on top of ceiling, refer 3

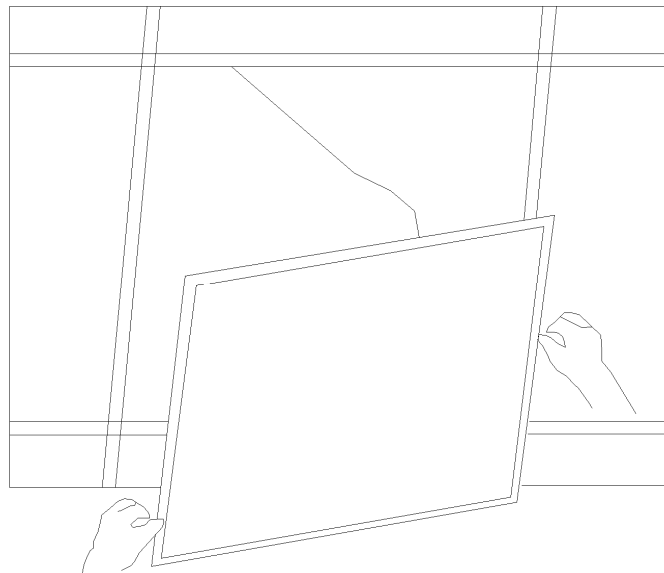

3

④. Finish and double check if secure and safe, refer 4.

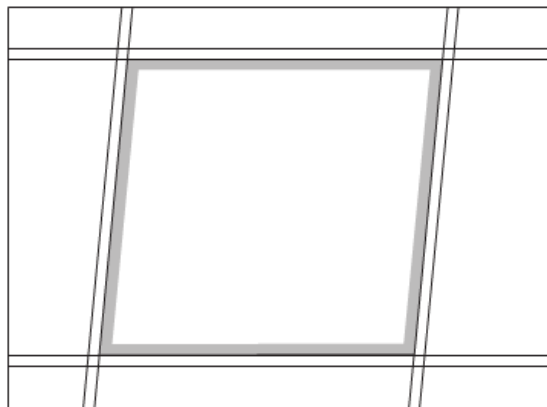

4

⑤. Turn on the power to light up the light panel with normally function, refer 5



5

2. Suspension Mount (option), refer 6. 7.

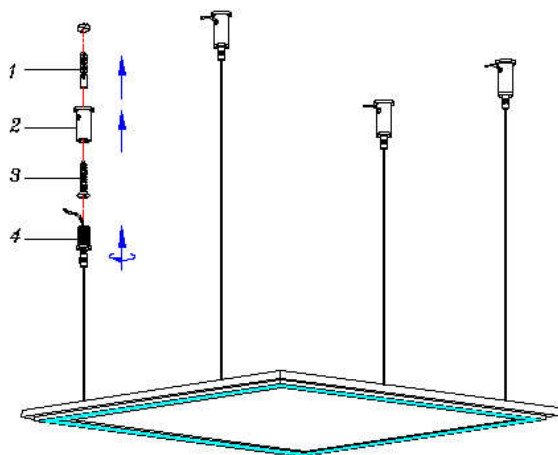

6.

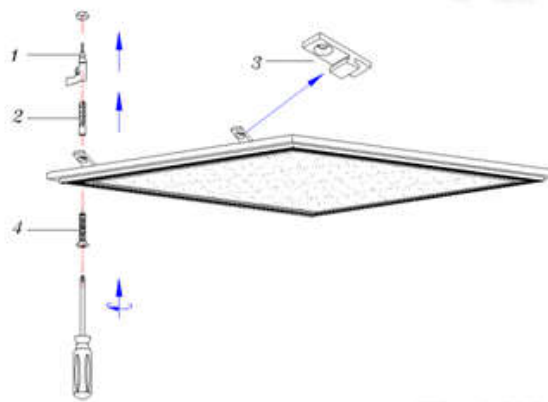

7.

1. Make sure that the ceiling can hold the weight of the LED panel and install ceiling brackets suitable to support the weight of the LED panel. Fixing cables.
2. Gather panel and connect the wires as shown in "Assembling panel".
3. Attach the suspended cables to the bends at the edges of the LED flat panel.
4. Turn on the main power. Installation is completed.

### 3. Surface Mount (option)

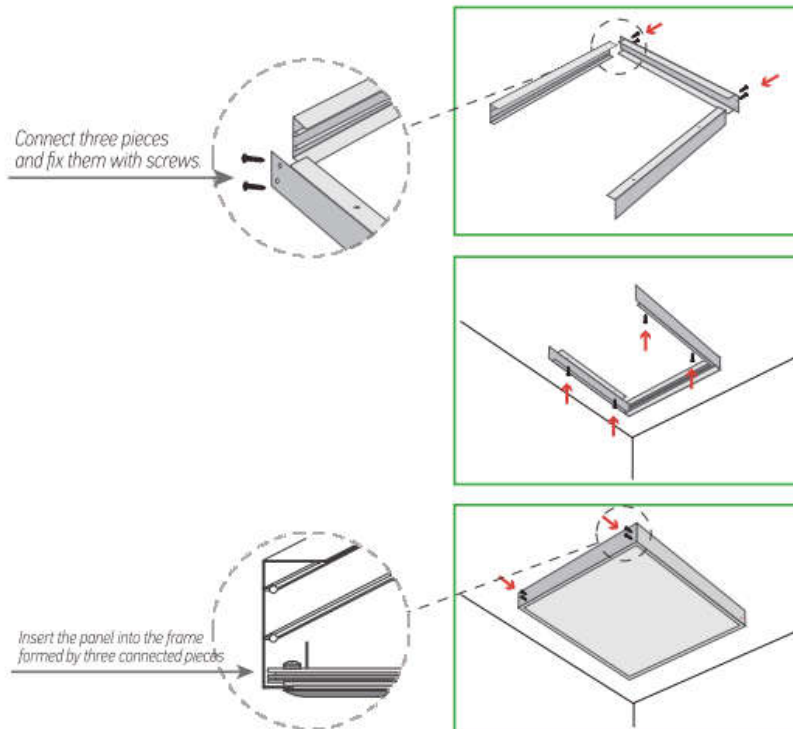

1. Put the pieces of frame to any horizontal surface.
2. Set two of these three pieces of frame (those ones that are parallel and that have come ponding holes in them) to the ceiling with four screws.
3. Gather panel and connect the wires as shown in "Assembling panel".
4. Close it with the fourth piece, set this piece to other ones with screws.
5. Turn on the main power. Installation is complete.



## Safety Notes:

1. Ensure the LED light size should be approximately equal with the mounted skeleton of ceiling tile size, otherwise it is not safely set up or it can be easily fall off
2. Ensure the skeleton can bear the weight of LED light before installation
3. **Switch the AC power OFF before installing**
4. Must be connect the grounding wire with light fixture and insulated when connect wires, to prevent circuit breaker or electric shock fuse, copper wire cannot be exposed
5. Place the power supply at a reasonable and safe position for convenient change or maintain; in order to avoid affecting ventilation and radiating and prevent fire, there shouldn't be any items within 50mm around power pack, especially flash point below 80-degree items;
6. This product is built as indoor light fixture, no waterproof certification. Forbid using outdoor or higher moist environmental
7. This product has dimming function, can be used with general standard dimmer (as option) or provided 2.4G remote control
8. Store products in cool, dry and clean environment if unused for long time
9. **Highly recommended having professional/licensed contractor/tech to install/setup and maintain, otherwise, could be unsafe and/or caused the damage**

### Five Years Limited Warranty

EESGI guarantees this product to be free from defects in material & workmanship for (5) year.

This warranty does not apply to damage from misuse or incorrect installation/ connection.

This warranty does not cover accessories, bulbs, batteries, high voltage accidents, alterations, unauthorized use or repair, neglect, misuse, abuse, damages or defects resulting from normal wear and tear (including chips, fading scratches, abrasions or discoloration due to usage or sun exposure), or failure to follow instructions for care and maintenance, fire, flood, and Acts of God.

This warranty does not include liability for incidental or consequential damages.

EESGI is not responsible for any damages in excess of the retail purchase price of the product under any circumstances. The consumer is responsible for the installation of, removal of, and reinstallation of the product.

**Customer service:** (877)579-3889, info@eesgi.com

Rev. EEBPTL 102021