

The Performance Accessories multifunctional 4-in-1 molding allows you to utilize a single transition to create four different applications.

Please DO NOT discard the shims. Refer to the instructions for the specific profile you are installing for details on how to use the shims. Refer to the installation instructions provided by the flooring manufacturer for required expansion spaces.

STEP 1 • REVIEW INSTALLATION CHECKLIST

- Inspect the moulding cover and track. Ensure that the channel on the moulding cover is uniform in width along the entire length.
- Do not push parts into track until ready to install in final position.
- Do not remove from track once installed.
- Use a new 60–120 fine-tooth finishing saw blade for flooring for best cutting results.
- Use tin snips or a heavy duty cutting tool to cut the track and shims.
- Depending on moulding type, all parts may NOT be used.
- Always install screws in end holes of track and then every other hole.
- For concrete floors, drill hole using 3/16" (5mm) diameter concrete drill bit, insert plastic anchor, then use screw.
- Depending on the floor height, attach the shims or track directly to the subfloor (*remove any padding or underlayment*).
- This product has been finished for you; do not sand or paint.

STEP 2 • CHOOSE YOUR TRANSITION TYPE

The kit allows assembly of four different molding options from one single product.

- A. Carpet Transition**
The carpet transition provides a smooth transition between your hard surface floor and carpet.
- B. T-molding**
The T-molding is used to transition between flooring of equal heights and in doorways.
- C. End Molding**
The end molding can be used to finish flooring where it meets vertical surfaces such as walls, fireplace hearths and sliding glass doors.
- D. Hard Surface Reducer**
The hard surface reducer connects two floors of different heights.

STEP 3 • INSTALL YOUR MOLDINGS

Each individual package includes the following:

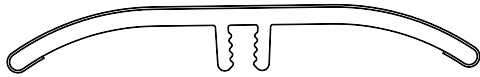

1. Molding/Profile

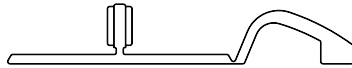

2. Track

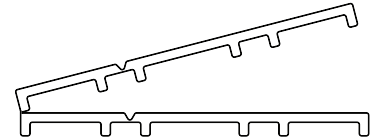

3. Shim

1. Leave a 1-1/2" space between the two surfaces to be joined.
2. Separate the shims into two separate pieces of even widths where folded. Use a utility knife if needed.
NOTE: The universal shim is provided in one single piece. After separating, follow the specific diagrams in these instructions for shim assembly with your flooring height.

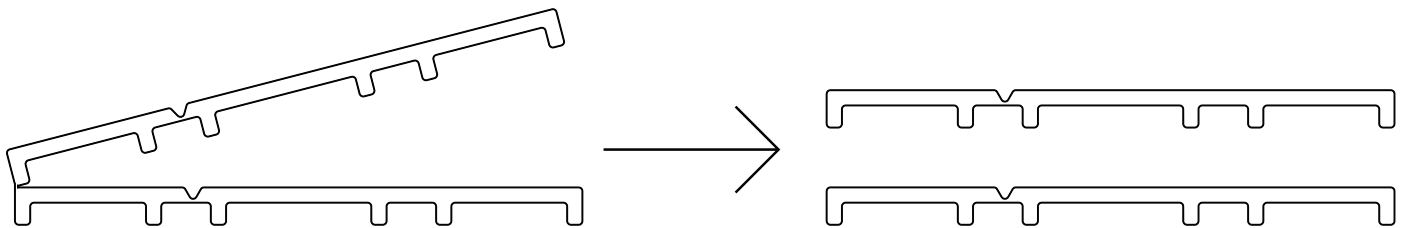

3. If installing as a T-Moulding or Hard Surface Reducer only, remove the narrow portion of each of the two shim pieces. **DO NOT** remove this piece if installing as carpet transition or end moulding.

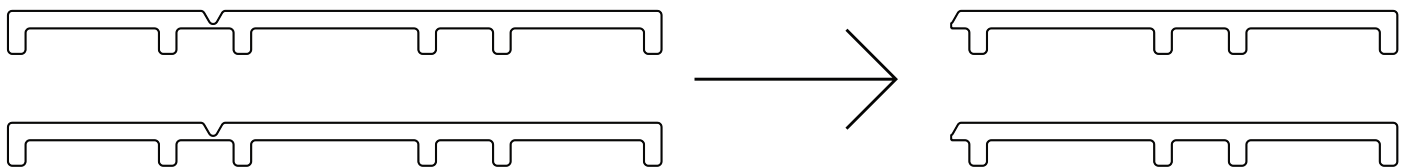

4. Measure the area where the moulding will be installed. Transfer measurements to the moulding cover, shims and track and trim to fit.
5. Using proper shim configuration as outlined, begin install of shims and track. Using a polyurethane glue, place a bead of glue between the subfloor and bottom shim, between the shims (*if needed for configuration*), and between the top shim and track. Ensure that excess glue is not used so that floating floor cannot bind to track. Once glue is applied with track and shim(s) in place, fasten the shims and track to the subfloor using wood screws or ring shank nails.
If installing onto concrete subfloor, drill anchor holes using a 3/16" diameter concrete drill bit, and utilize concrete anchors and screws. With shim and track fastened, you are now able to install the transition cover onto the track.
6. Line up cover with track. Start at one end and use a rubber mallet to tap the track and cover together. Push down firmly onto track, working from one end to the other.

A. T-MOLDING

The T-molding is used to transition between flooring of equal heights and in doorways.

1. Remove carpet/end molding transition support from track with utility knife.

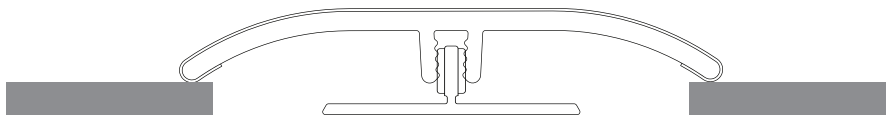
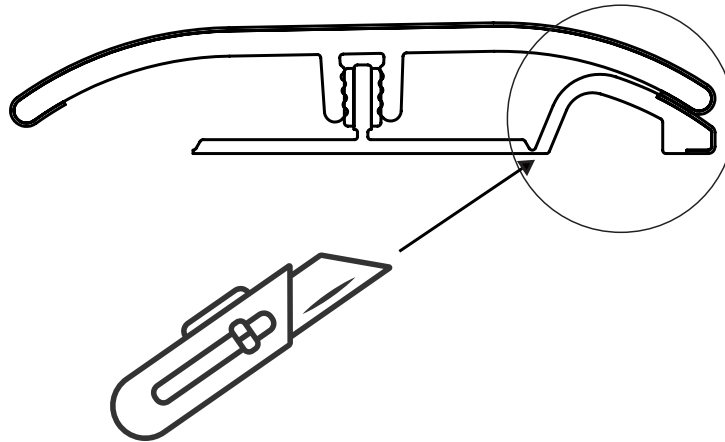

Flooring thickness = 2mm - 3mm

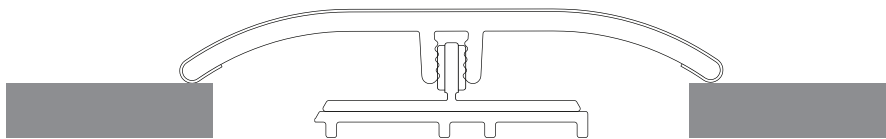

Flooring thickness = 4mm - 5mm

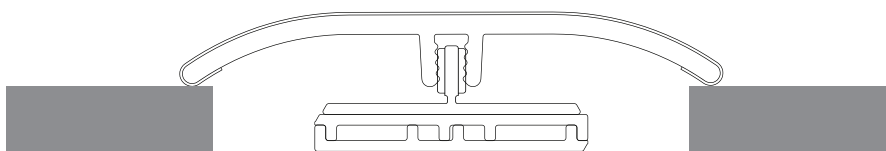

Flooring thickness = 5mm - 6mm

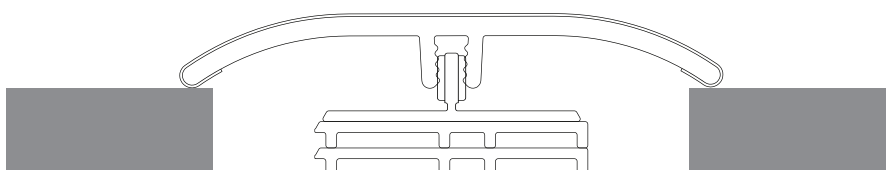

Flooring thickness = 7mm - 8mm



B. CARPET TRANSITION

The carpet transition provides a smooth transition between your hard surface floor and carpet.

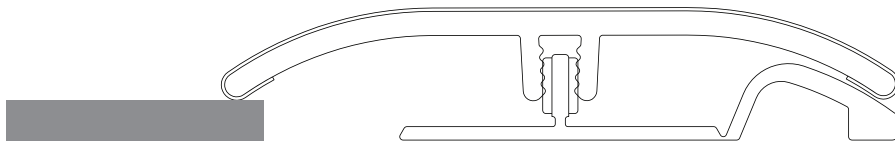

Flooring thickness = 2mm - 3mm

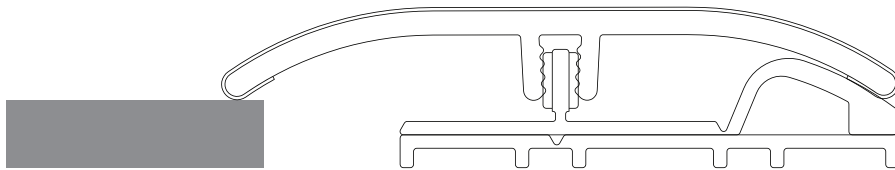

Flooring thickness = 4mm - 5mm

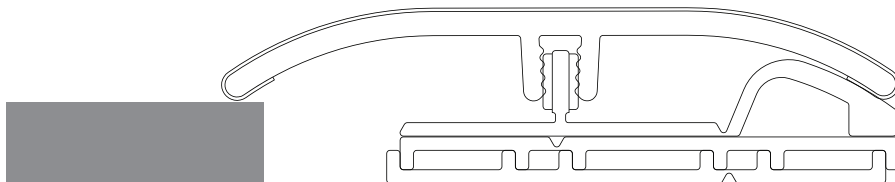

Flooring thickness = 5mm - 6mm

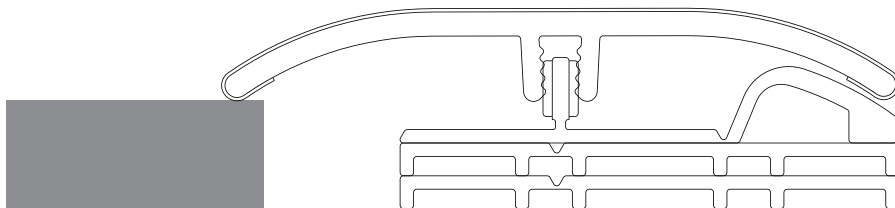

Flooring thickness = 7mm - 8mm

C. HARD SURFACE REDUCER

The hard surface reducer connects two floors of different heights.

1. Remove carpet/end molding transition support from track with utility knife.

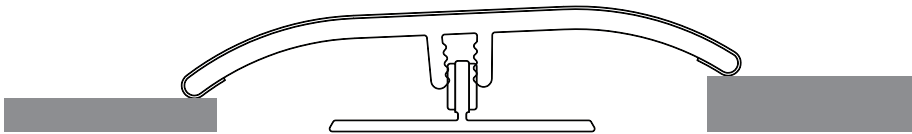
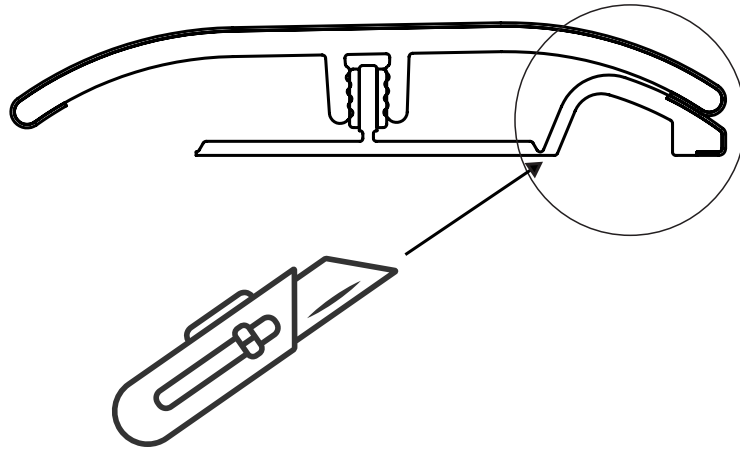

Flooring thickness = 3mm - 5mm

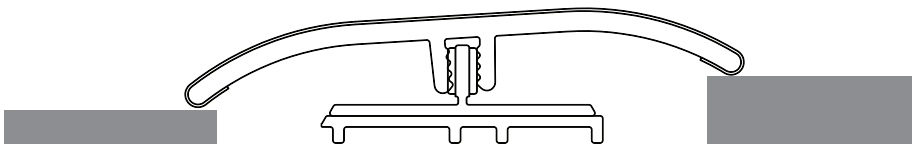

Flooring thickness = 6mm - 7mm

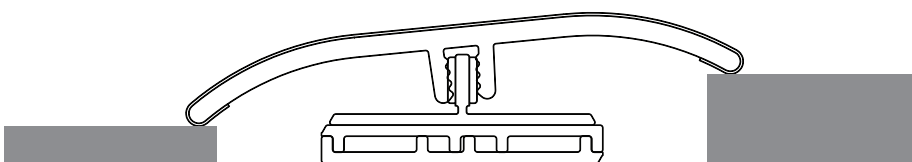

Flooring thickness = 8mm



D. END MOLDING

The end molding can be used to finish flooring where it meets vertical surfaces such as walls, fireplace hearths and sliding glass doors.

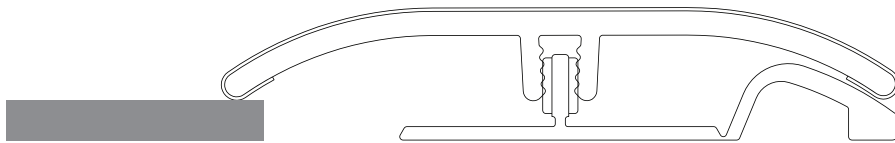

Flooring thickness = 2mm - 3mm

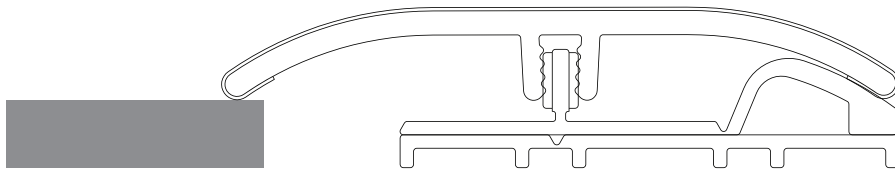

Flooring thickness = 4mm - 5mm

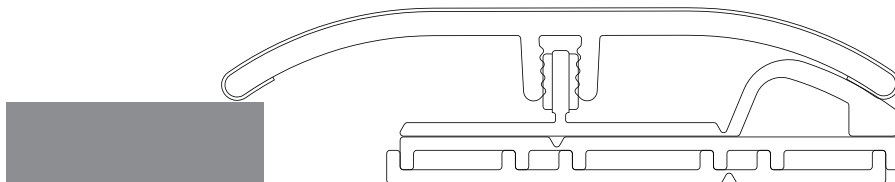

Flooring thickness = 5mm - 6mm

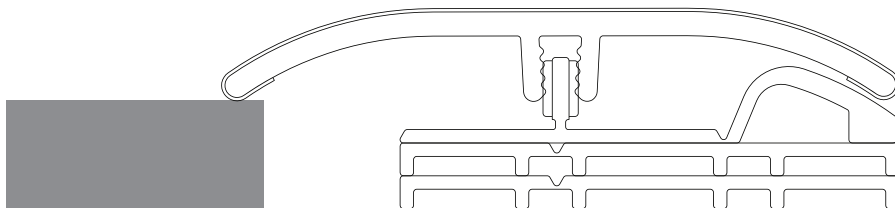

Flooring thickness = 7mm - 8mm