

## HARDWARE PACKAGE

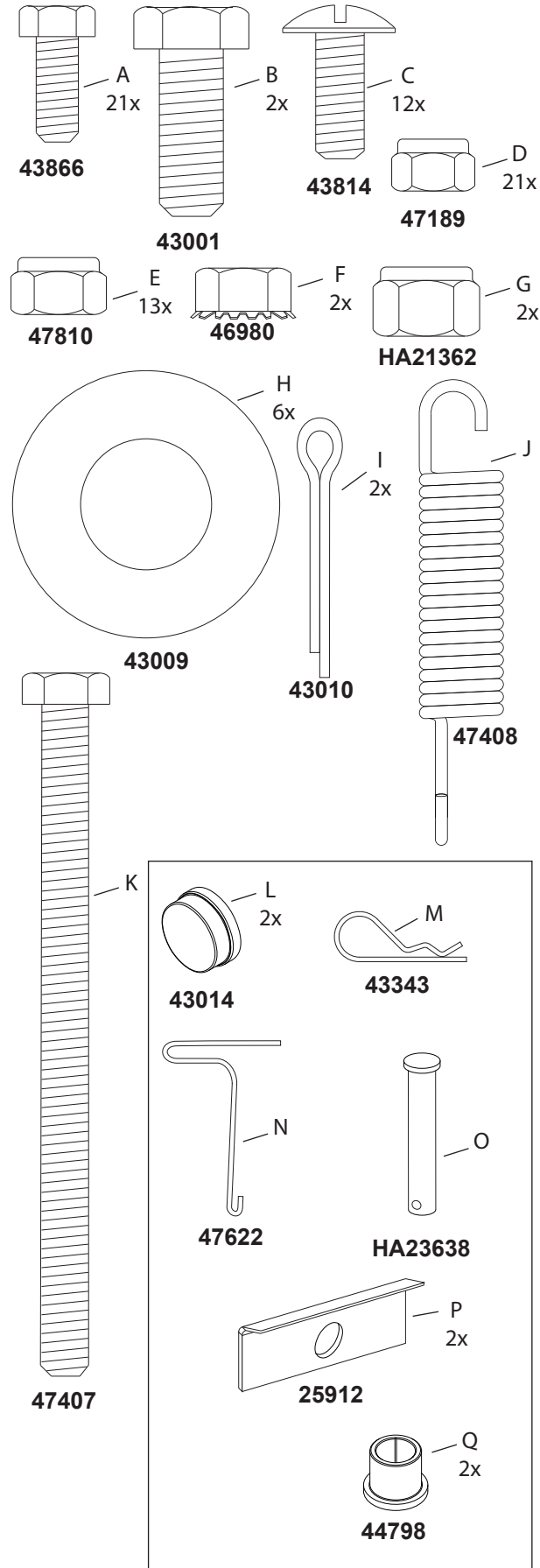

**STEP 1 (SEE FIGURE 1):** Assemble the cart body using three 1/4" x 5/8" hex bolts (A) and 1/4" nylock nuts (D).

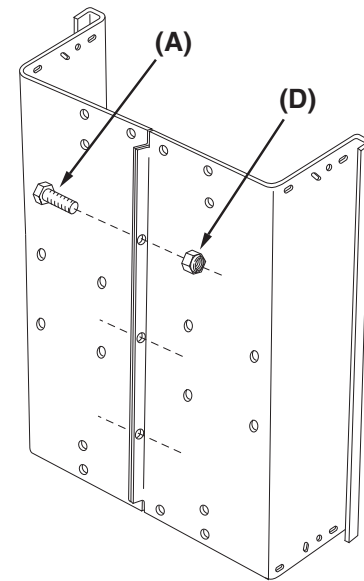

Figure 1

**STEP 2 (SEE FIGURE 2):** Attach the tailgate reinforcement bracket (6) to the assembled cart body using four 5/16" x 3/4" truss head bolts (C) and 5/16" nylock nuts (E). Attach the tailgate guides using two 1/4" x 5/8" hex bolts (A) and 1/4" nylock nuts (D) on each side.

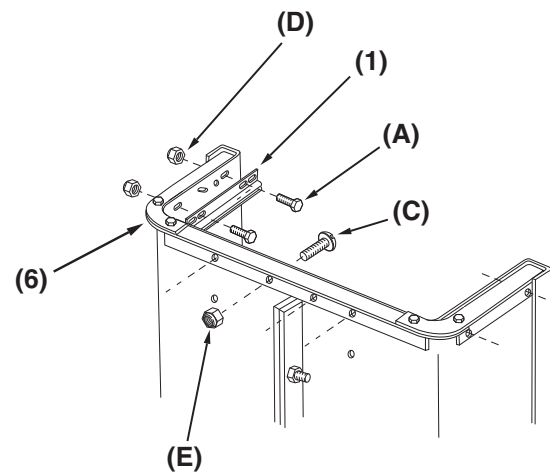

Figure 2

**STEP 3 (SEE FIGURE 3):** Position the cart bed with the rear of the cart facing towards the ground. Attach the front panel (8) using four 1/4" x 5/8" hex bolts (A) and 1/4" nylock nuts (D).

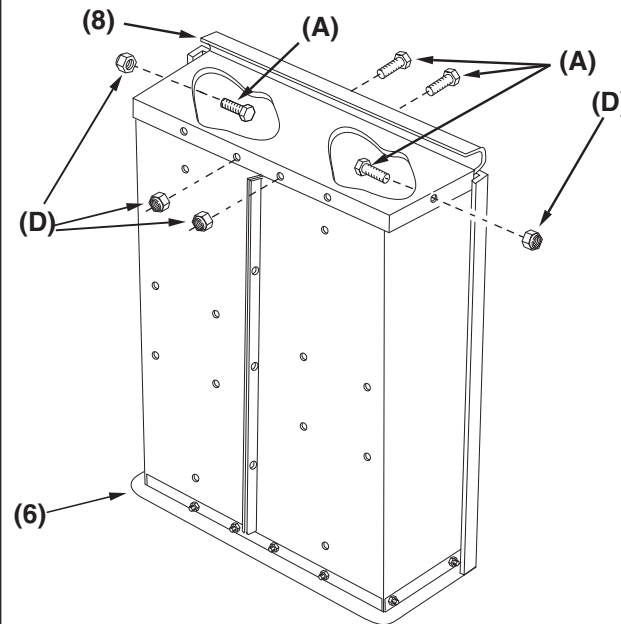

Figure 3

**STEP 4 (SEE FIGURE 4):** Attach the wheel support (9) to the cart bed using eight 5/16" x 3/4" truss head bolts (C) and 5/16" nylock nuts (E).

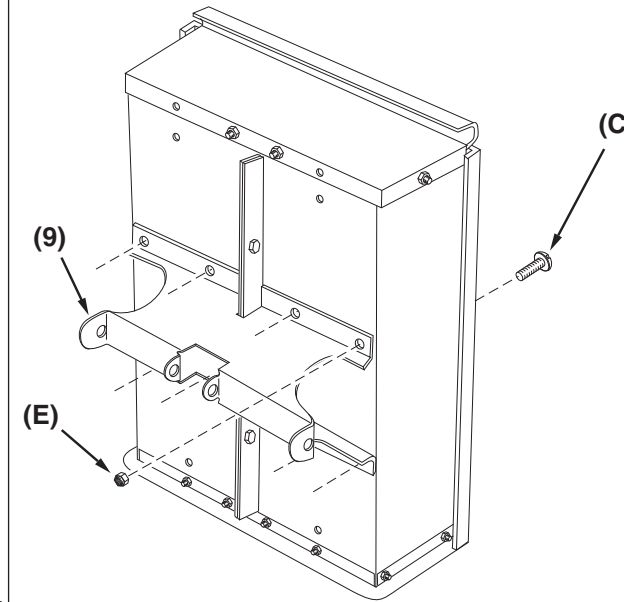

Figure 4

**STEP 5 (SEE FIGURE 5):** Attach the latch stand bracket (5) using four 1/4" x 5/8" hex bolts (A) and 1/4" nylock nuts (D). Make sure the tab in the latch stand bracket is positioned closest to the rear of the cart as shown below.

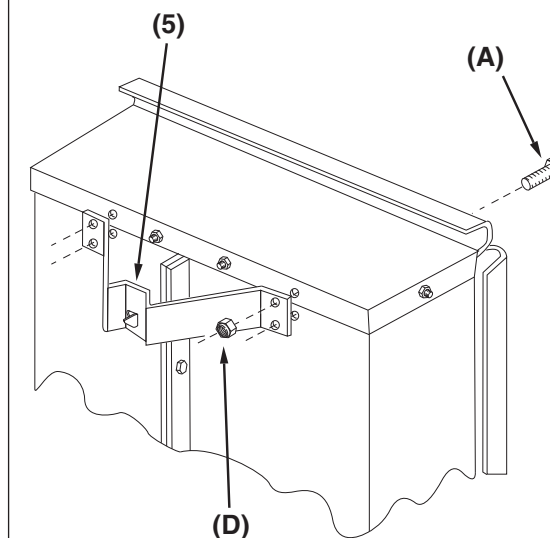

Figure 5

**STEP 6 (SEE FIGURE 6):** Attach the front corner caps (2) to the front of the cart bed using four 1/4" x 5/8" hex bolts (A) and 1/4" nylock nuts (D). Secure the tailgate reinforcement bracket to the cart bed using two 1/4" x 5/8" hex bolts (A) and 1/4" nylock nuts (D).

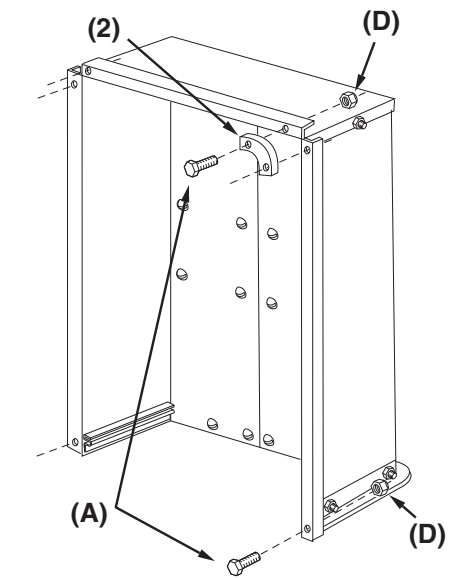

Figure 6

**STEP 7 (SEE FIGURE 7):** Insert two flanged bearings (Q) into the tongue (11) as shown below.

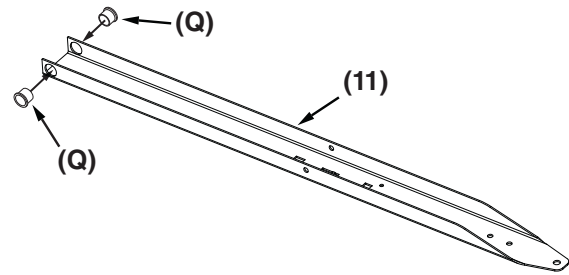

Figure 7

**STEP 9 (SEE FIGURE 9):** Install the foot pedal (3) by inserting a 5/16" x 4" hex bolt (K) through one side of the tongue, a 5/16" SEMS hex nut (F), the foot pedal (3), a 5/16" SEMS hex nut (F), and the tongue. Secure with a 5/16" nylock nut (E). Be sure to center the foot pedal on the bolt between the two SEMS nuts as shown below.

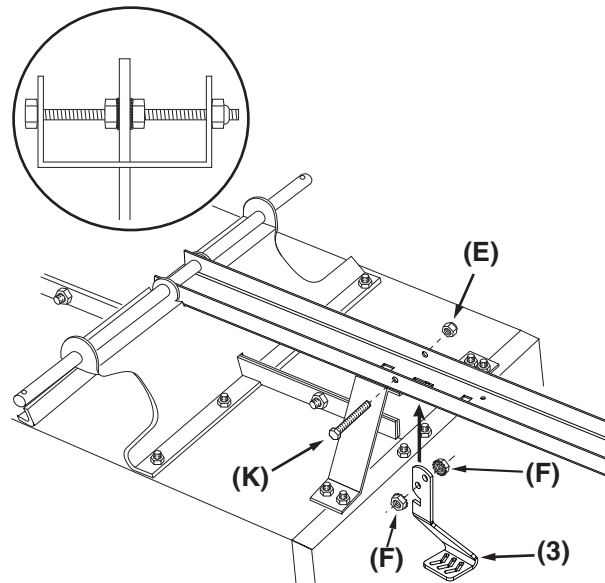

Figure 9

**STEP 8 (SEE FIGURE 8):** Install the axle (10) through the wheel support and tongue (11) as shown below.

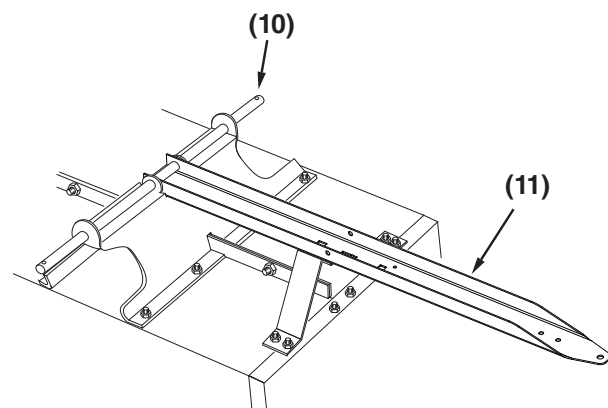

Figure 8

**STEP 10 (SEE FIGURE 10):** Install the extension spring (J) by attaching one end to the hole in the foot pedal (3). Use the spring puller tool (N) to attach the other side of the spring to the tongue as shown below.

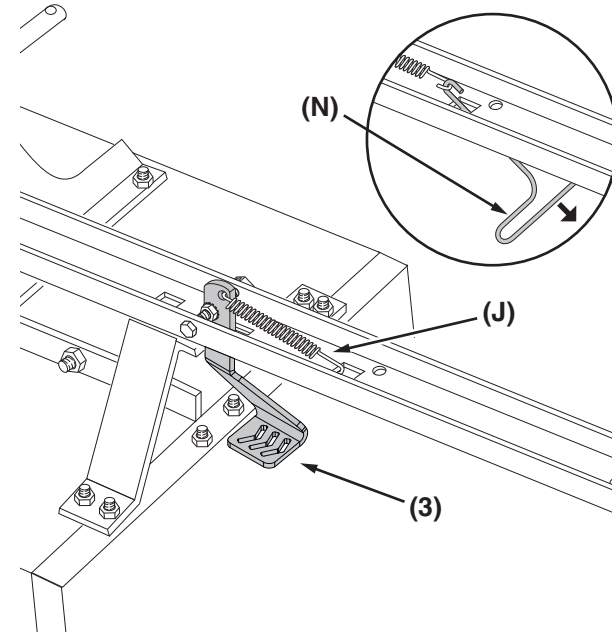

Figure 10

**STEP 11 (SEE FIGURE 11):** Install onto the axle (10) an axle clip (P), a 1/4" washer (H), a wheel (13), two 1/4" washers (H), a cotter pin (I) and a hub cap (L). Be sure to spread the ends of the cotter pin to secure the wheel. Repeat for the other side.

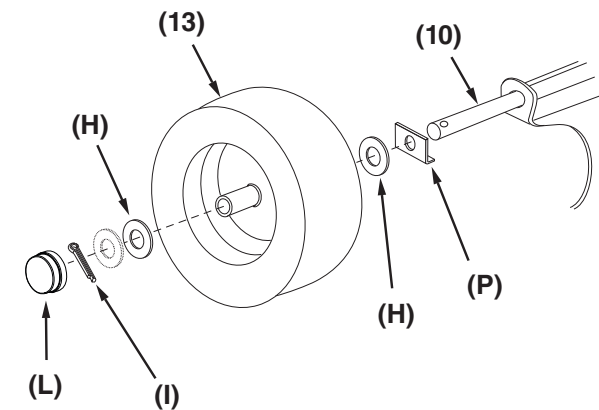

Figure 11

**STEP 12 (SEE FIGURE 12):** Attach the hitch bracket (4) to the tongue (11) using two 3/8" x 1" hex bolts (B) and 3/8" nylock nuts (G). Insert the hitch pin (O) and secure with 1/8" hair cotter pin (M).

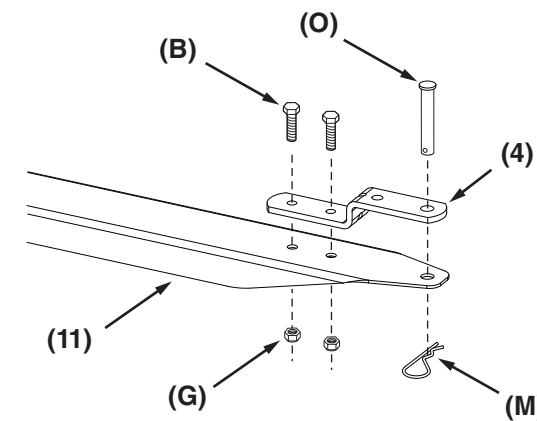

Figure 12