

MODEL RTA-8404

ASSEMBLY INSTRUCTIONS

Thank you for purchasing our product.

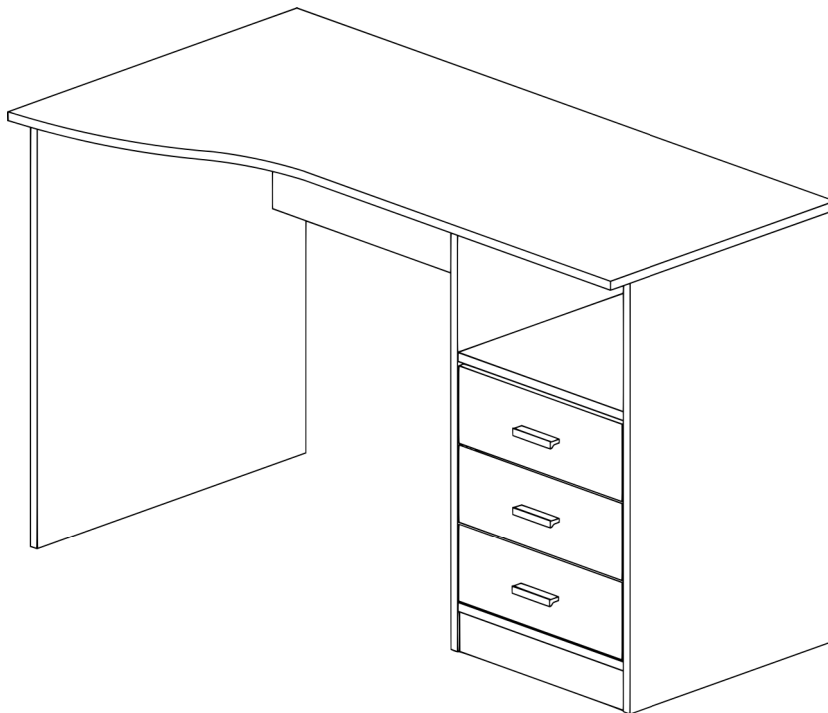



- Please read carefully the assembly instructions before the installation.







- Do not discard this manual or any of the packaging material until the unit has been completely assembled.

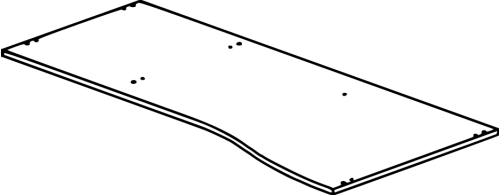
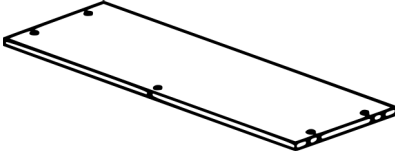
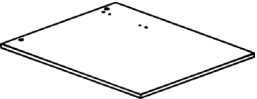
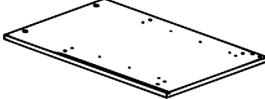
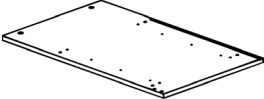
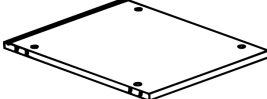
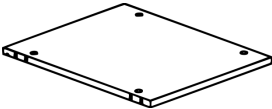
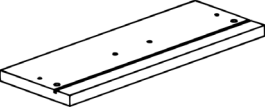
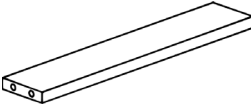

- Might require two people.



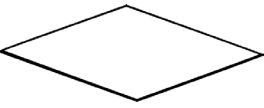
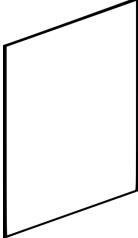



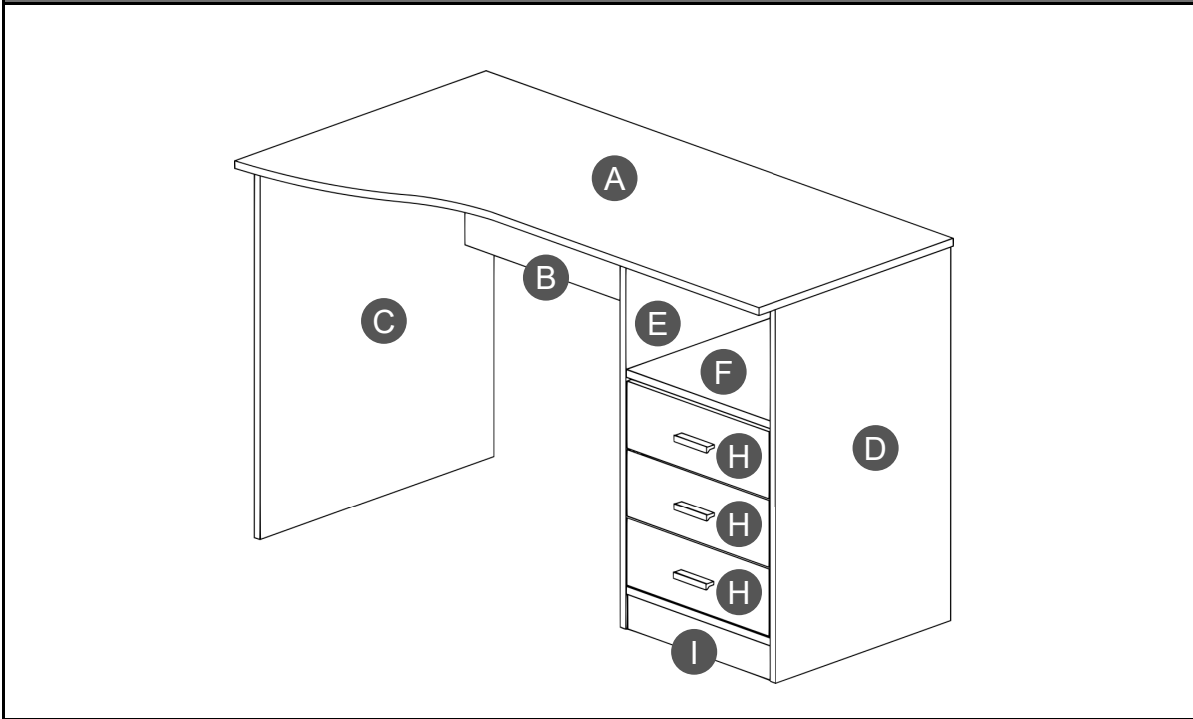

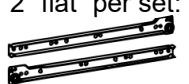

MAIN PARTS LIST

A x1 Tabletop 	B x1 Left back panel 		
C x1 Left panel 	D x1 Right panel 	E x1 Middle panel 	F x1 Right shelf panel 
G x1 Bottom panel 	H x3 Drawer front panel 	I x1 Bottom skirt panel 	J x3 Drawer left panel 
K x3 Drawer right panel 	L x3 Drawer back panel 	M x3 Drawer bottom panel 	N x1 Right back panel 

MAIN PARTS LAYOUT (FOR REFERENCE):

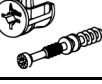

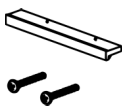
LIST OF HARDWARE, SCREWS AND FITTINGS

PART	QTY	ITEM		PART	QTY	ITEM	
1	28	Wooden dowel					
2	12	ST5x8 Euro screw		7	3 sets	Sliders, set of 4 pcs	
3	4	ST3x16				2 "L" per set:	
4	12	ST4x38		8	6	Plastic glide	
5	25 sets	Cam bolt and lock		9	2	Z Bracket	
6	17	Hole cover		10	3 sets	"L" handle 84mm plus 2 screws M3.6x22	
				11	12	ST3.5x15	

NOTE: You will need for the assembly a Phillips screwdriver and mallet/hammer (not included).

▣ This unit uses cam bolts and locks. The following explains how to use them. This is not an assembly step; it is a guide for when you are actually doing the assembly using this kind of hardware.

Cam Lock



Cam Bolt

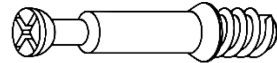

1. Screw the bolt into the corresponding hole on panel "A".

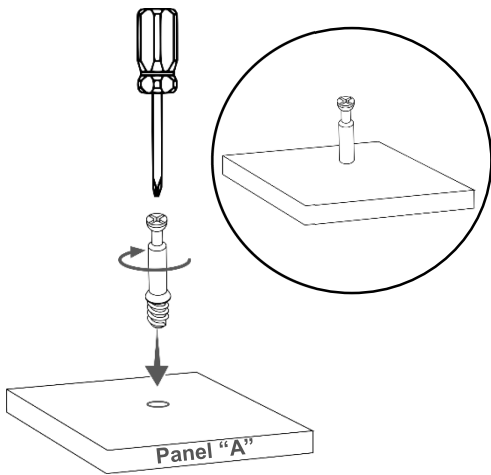

2. Join panel "B" to panel "A". If panel "B" comes with the cam lock pre-installed, make sure it is aligned to receive the bolt's head (refer to point 3). There might be a very small gap between the panels which is normal.

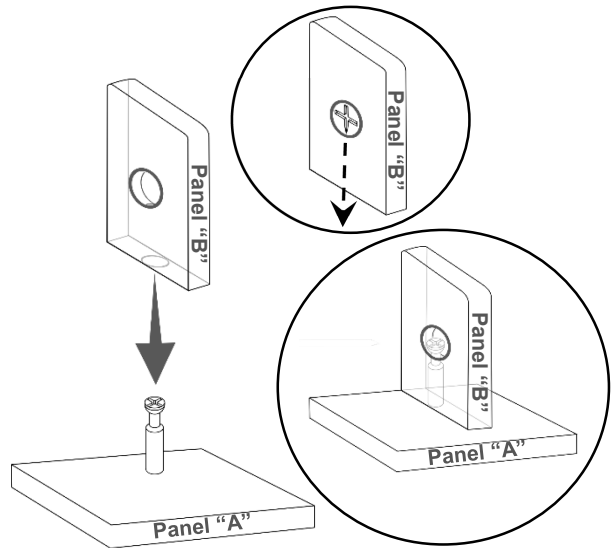

3. Insert the cam lock on panel "B" making sure it goes aligned to receive the bolt's head.

Alignment: The cross points towards the panel "A" with the bolt.

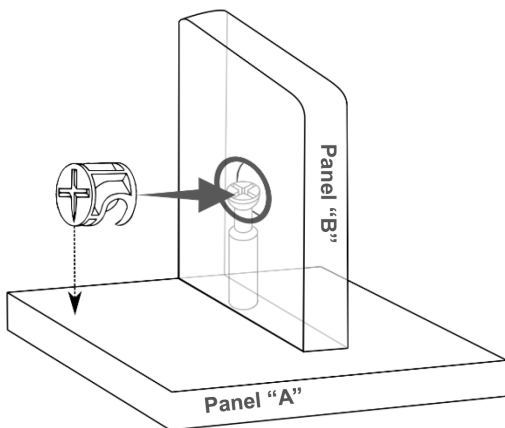

4. Turn the cam lock clockwise. This will lock the parts together and will close any gaps.

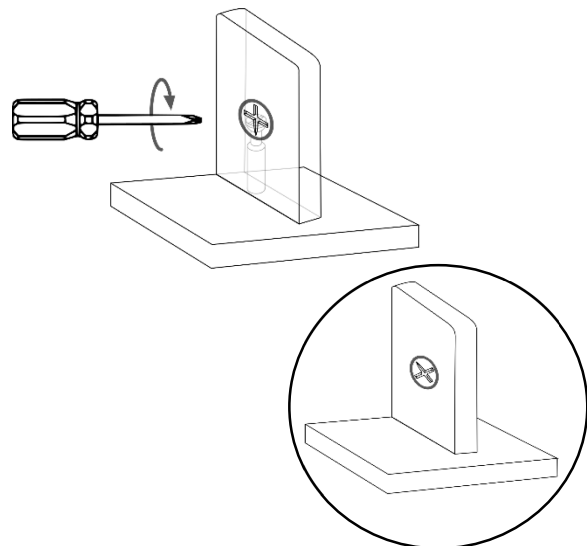

BEFORE YOU START THE ASSEMBLY, PLEASE READ THE FOLLOWING TIPS AND WARNINGS.

1 Do a quick inventory to make sure the package contains all the parts and hardware listed in the assembly instructions.



7 To avoid misalignments, always leave the screws loose and tighten them until all pieces are positioned correctly.

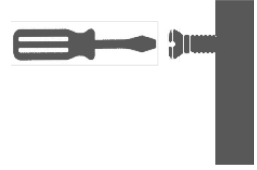

2 Missing, damaged and defective parts can be replaced at no cost to you. Please refer to the last pages on this manual.



8 Do not overtighten or force the screws as they might break, strip, damage the threads of the holes or get stuck inside the part.

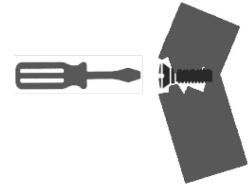

3 The replacement parts service is limited to the 48 contiguous United States. If you reside in Alaska, Hawaii, Puerto Rico, U.S. territories or other countries, please contact the supplier from where the unit was purchased.



9 Sometimes the laminate might cover partially or entirely the hole on a panel. If there is no visible hole for the screw, pass and press the tip of your finger over the area where the hole should be located to feel the indentation, and once found, carefully pierce the laminate to reveal the hole underneath.



4 If during assembly you find an issue or need clarification, please contact our Customer Service for assistance. Please refer to the last pages on this manual.



5 On each step read the instructions and analyze the illustrations thoroughly before proceeding to do the assembly.



10 If the hole seems too small for the screw, first make sure you are using the correct size of screw and that it's been installed in the correct hole. If the hole still appears to be too small, carefully pierce the laminate to reveal the hole's actual size.

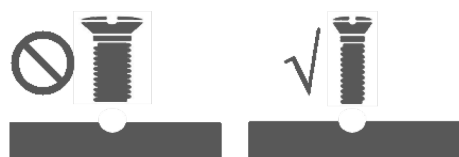

6 Make sure you understand which hardware will be used on each step. Using the wrong size of screw, bolt or pin might strip the threads or cause damage to the part in which it is being used.

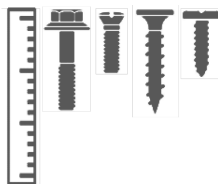

ASSEMBLY STEPS

STEP 1

Hardware:

1



Dowels

28
Pcs

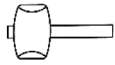

(NOT INCLUDED)

ATTENTION: DO NOT JOIN ANY PANELS IN THIS STEP!

Insert the wooden pins **1** into the indicated holes of panels **B, C, D, E, F, G, I, J** and **K** as shown. Make sure to insert in the correct holes as others are intended for other hardware in other steps.

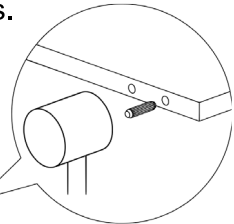
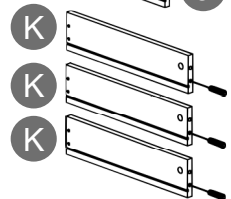
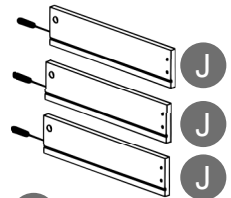
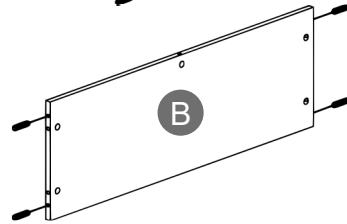
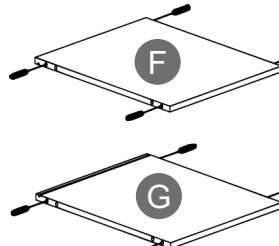
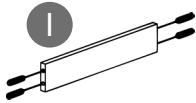
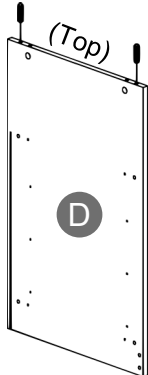
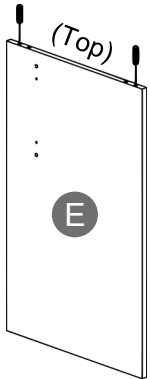
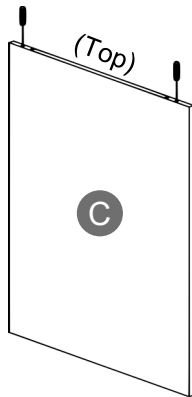

STEP 2

Hardware:

5



Bolts

25
Pcs

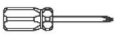

(NOT INCLUDED)

Attach the cam bolts **5** to the indicated holes on panels **A, C, D, E** and **H** as shown. Please make sure to insert them in the correct holes as others are intended for the wooden pins in subsequent steps. Please note that on panel **E** the bolts attach on both sides.

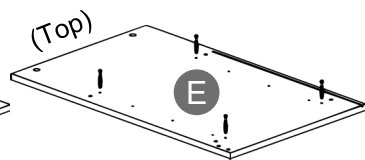
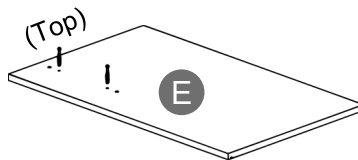
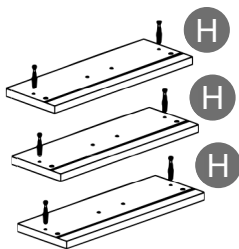
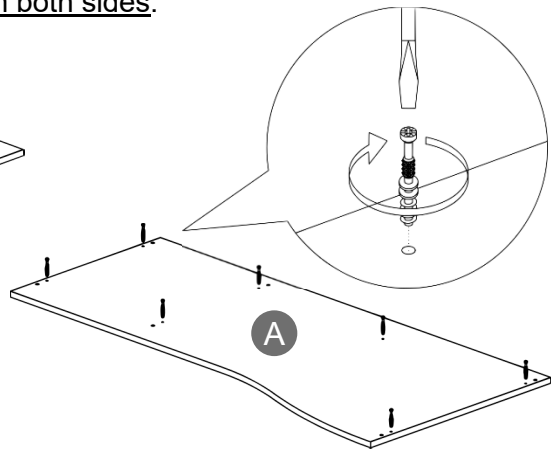
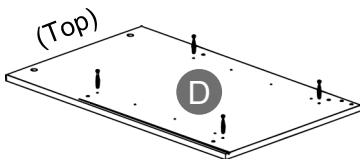
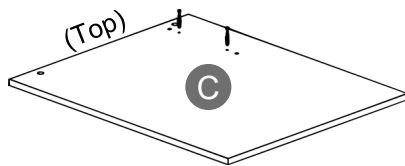



(Left side of panel)

(Right side of panel)

STEP 3

Hardware:

2	 M6x20 12 Pcs
7	 Flat sliders 6 Pcs

Grab the “flat” metal sliders 7 (the “L” shaped will be used until step 12, please set them aside). With the panels D and E positioned as shown, assemble the flat sliders using screws 2 as shown.

NOTES:

- The wheels go towards the front of the panels.
- There will be 2 free holes above the wheels.

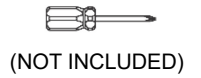
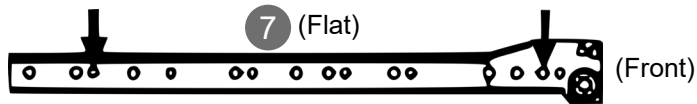

Scan QR Code to view this step

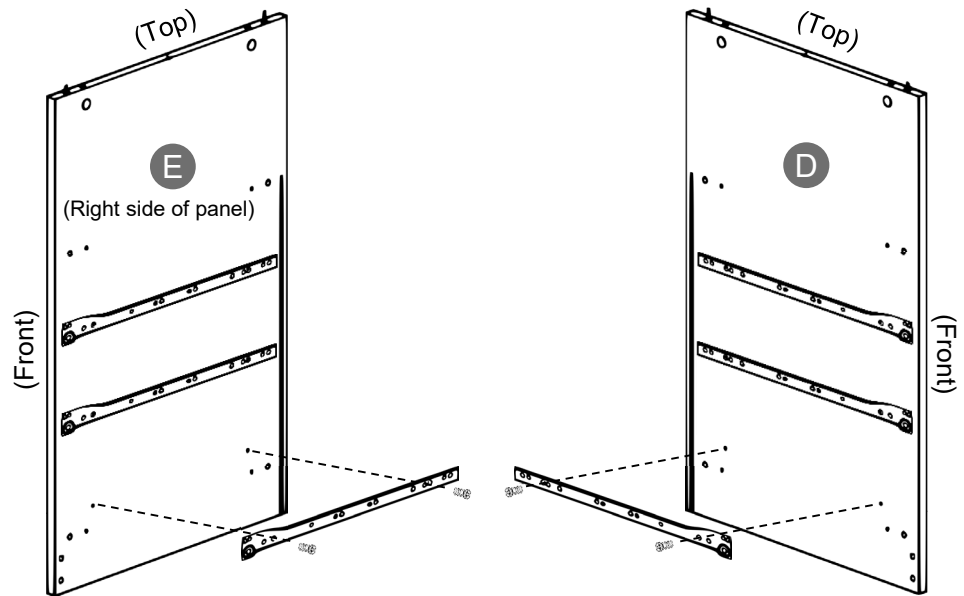

STEP 4

Hardware:

5	 Cam locks 4 Pcs
---	---

With the help of another person, join the panels C and E to panel B, insert and align the cam locks 5 into the corresponding holes on panel B, and turn them to lock the pieces as shown and as explained in page 4.

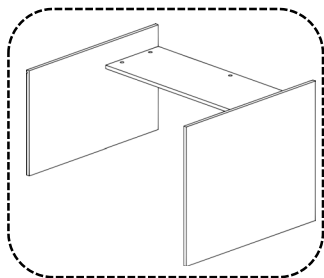
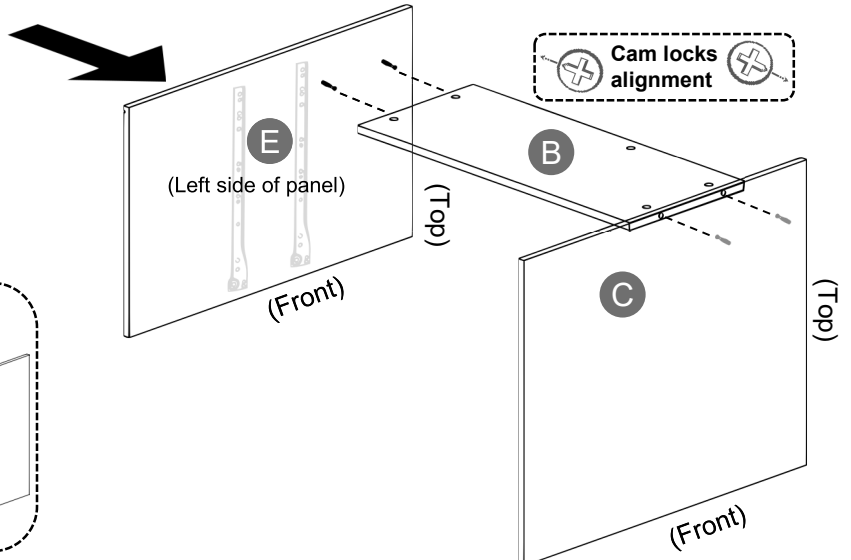
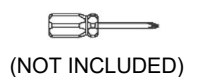

STEP 5

Hardware:

5



Cam locks

4 Pcs



(NOT INCLUDED)



With the help of another person, flip over the pieces assembled in step 4, and assemble the panels **F** and **G** to panel **E** with cam locks **5** as shown and as explained in page 4.

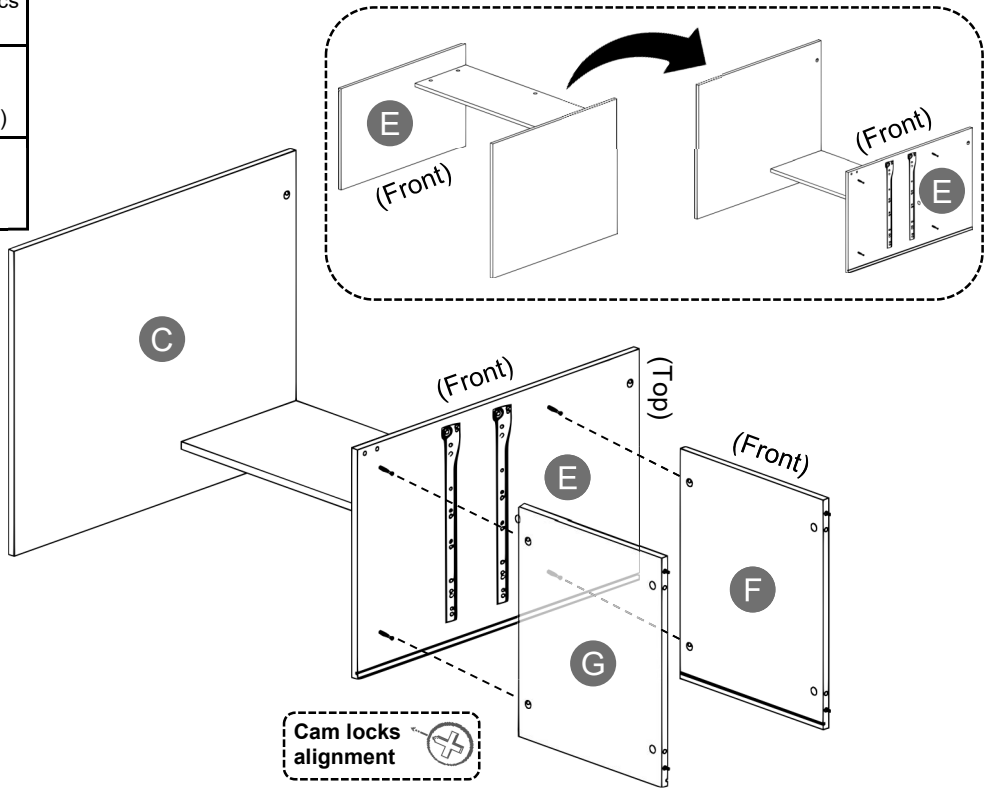

STEP 6

- Slide the back panel **N** through the grooves of panels **F** and **G** and into the groove of panel **E**.
- Attach the skirt panel **I** to panel **E** as shown.

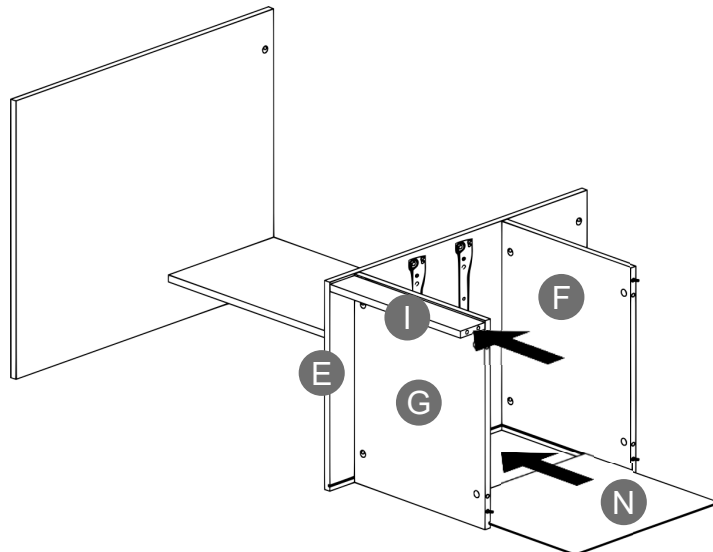

STEP 7

Hardware:

5



Cam locks

4 Pcs

8



Glides

6 Pcs

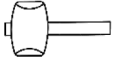

(NOT INCLUDED)

- Assemble the panel **D** to panels **F** and **G** with cam locks **5** as shown and as explained in page 4.
- Attach the plastic glides **8** to the bottom of panels **C**, **D** and **E**.

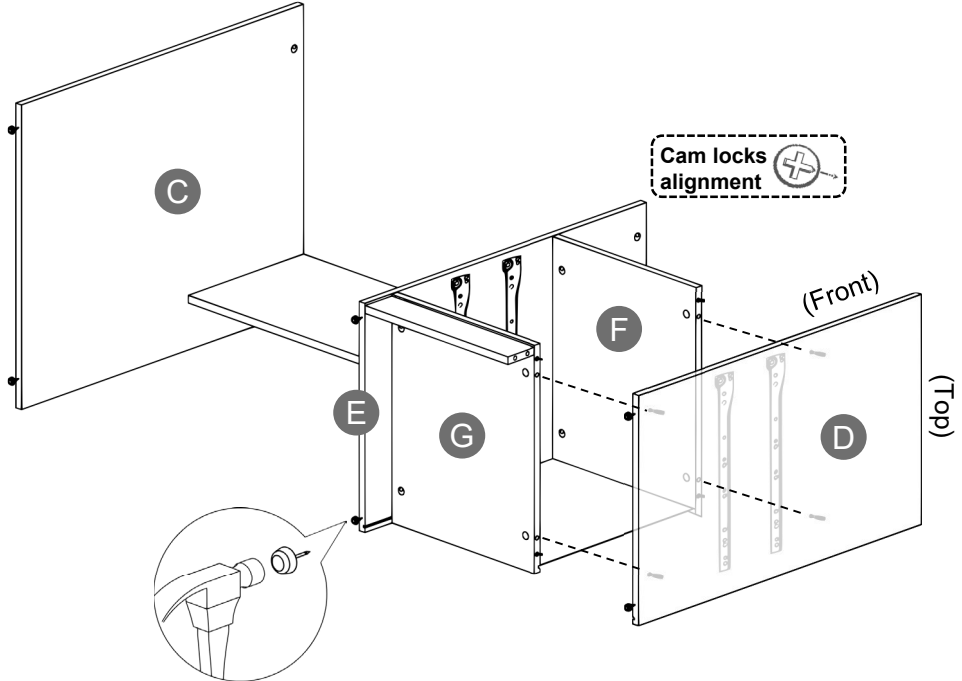

STEP 8

Hardware:

5



Cam locks

7 Pcs

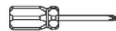

(NOT INCLUDED)



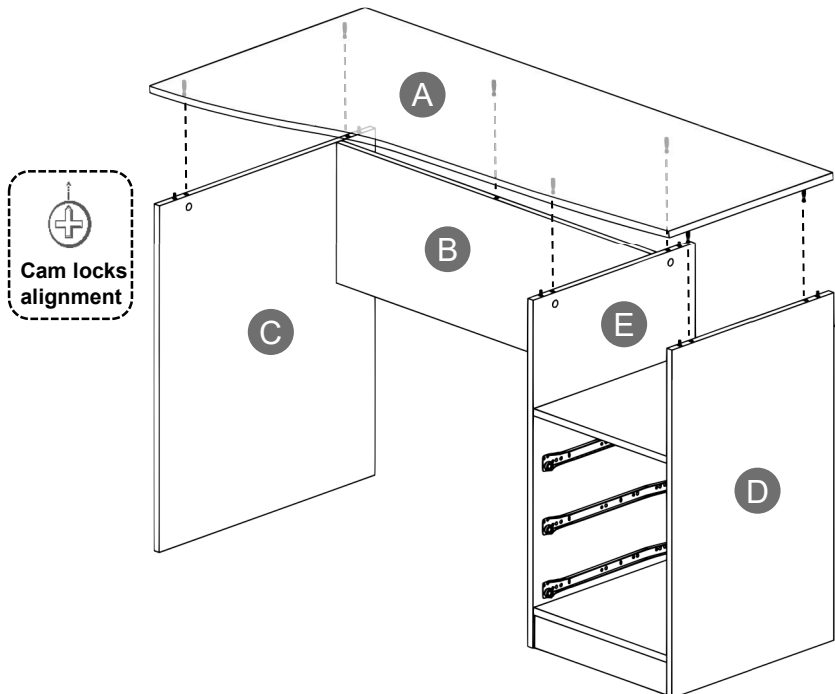

- With the help of another person, bring the unit built in step 7 to the upright position, and attach the tabletop **A** to panels **B**, **C**, **D** and **E** with cam locks **5** as shown and explained in page 4.



STEP 9

Hardware:

3	 ST3x16	4 Pcs
6	 Covers	11 Pcs
9	 Z Bracket	2 Pcs

(NOT INCLUDED)

- Attach the Z brackets **9** to the upper corners of the back panel **N** with screws **3**.
- Install the hole covers **6** over the cam locks on the indicated places.

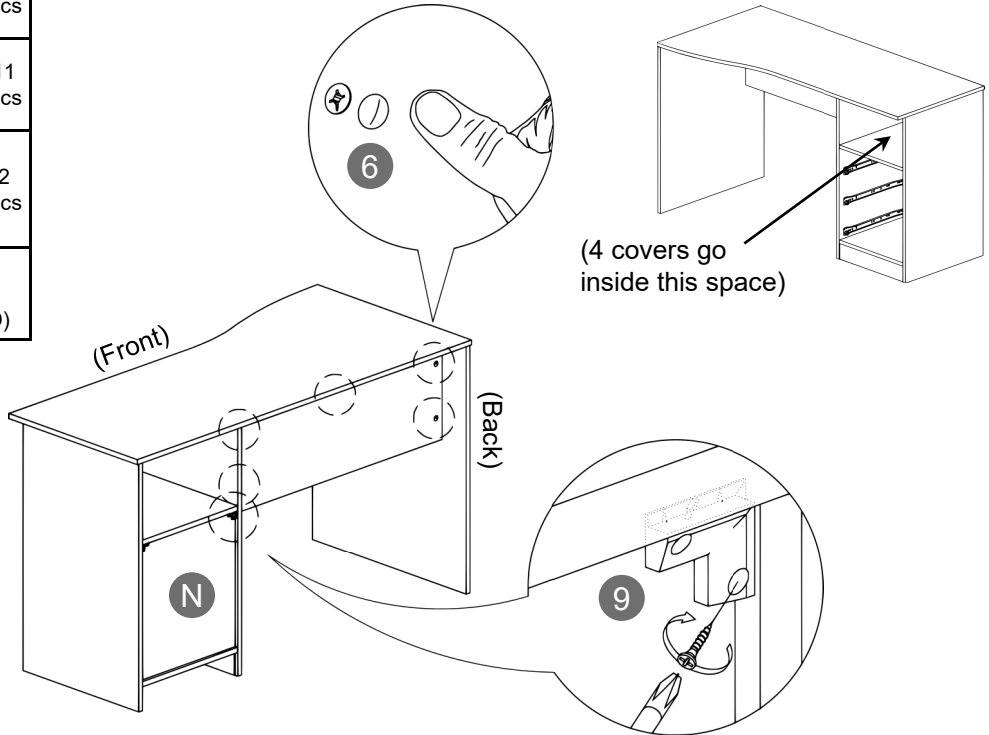

STEP 10

Hardware:

5	 Cam lock	6 Pcs
----------	---	----------

- For each of the 3 drawers, assemble the side panels **J** and **K** to the front panel **H** with cam locks **5** as shown and as explained in page 4.
- Slide the bottom panel **M** through the grooves of panels **J** and **K** and into the groove of panel **H** as shown.

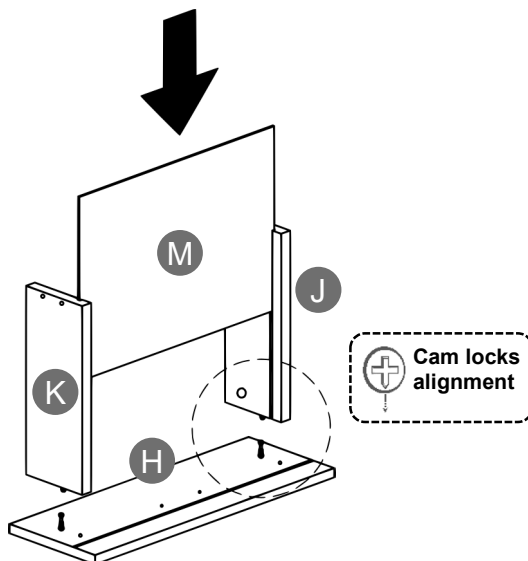

STEP 11

Hardware:

4  **12 Pcs**
ST4x38

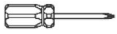

(NOT INCLUDED)

For each of the 3 drawers, assemble the back panel **L** to the side panels **J** and **K** with screws **4** as shown.

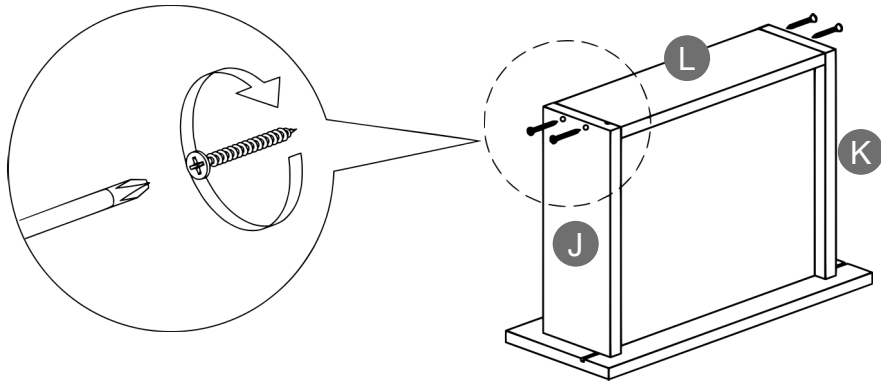

STEP 12

Hardware:

7  **6 Pcs**
L Sliders

11  **12 Pcs**
ST3.5x15

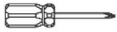

(NOT INCLUDED)

For each of the drawers, assemble the L shaped sliders **7** to the bottom of the drawer with screws **11** as shown.

NOTES

- The wheels go towards the back of the drawer.
- If assembled incorrectly, the drawers will raise 1" and won't fit.

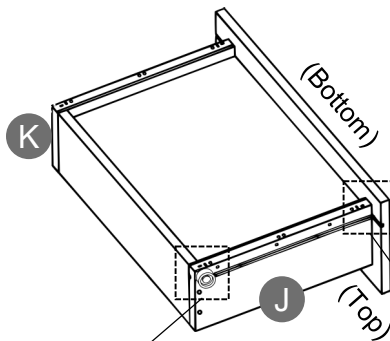
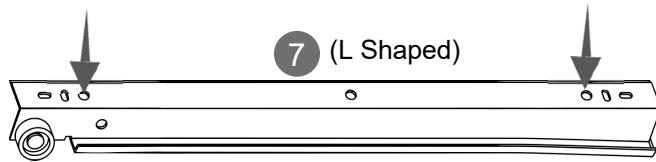

When finished, the sliders should look like this from the back of the drawer:

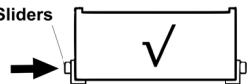
Sliders 

The following is incorrect, will raise 1" and the drawer won't fit:

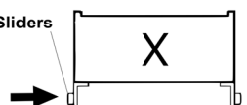
Sliders 

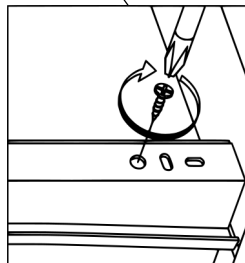
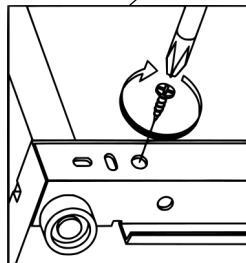

Scan QR Code to view this step

STEP 13

Hardware:

6



Covers

6
Pcs

10

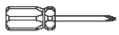
Handle +
2 screws3
Sets

(NOT INCLUDED)

For each of the 3 drawers, install the handle **10** to the front panel **H** using its own screws, then cover the cam lock holes on panels **J** and **K** with **6** as shown.

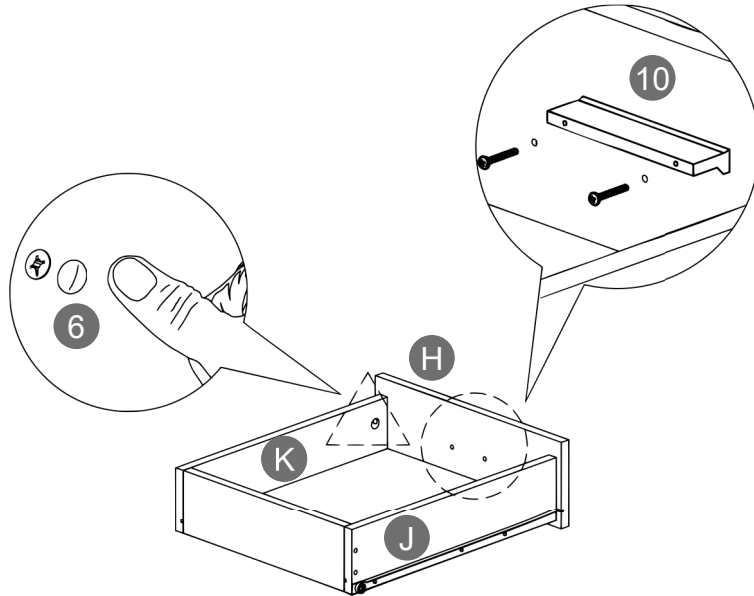

STEP 14

Insert the drawers into the unit starting with the bottom, then middle, and finally the top one. You might have to insert them at an angle facing down.

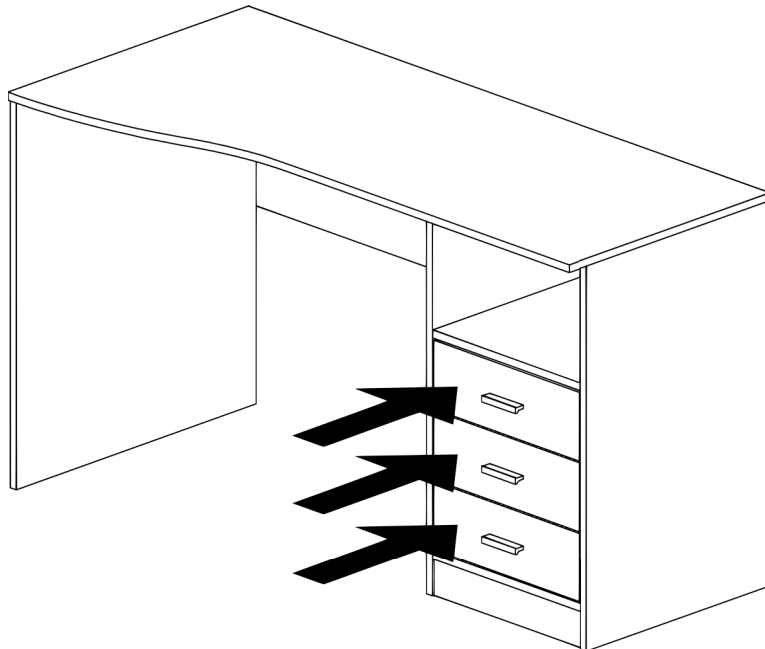

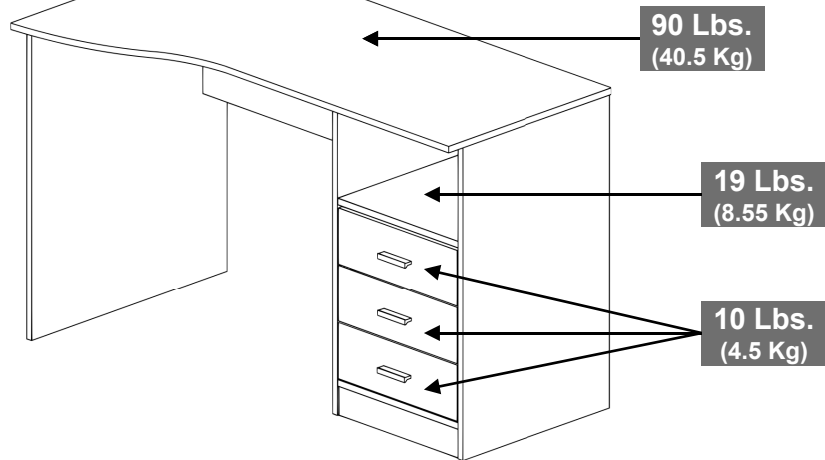
CARE, MAINTENANCE AND SAFETY WARNINGS:**WEIGHT LIMITS**

- Do not exceed the indicated weight limits.
- Do not expose the surfaces to direct sunlight or to extreme environmental conditions.
- Clean the surfaces preferable with a clean cloth damped in a solution of mild soap and water, then dry with a clean towel.
- Do not use solvents or abrasive materials to clean the unit.
- If you decide to use a cleaning agent, test first on an area hidden from view such as underneath the tabletop.
- Do not sit on the unit or lean against it.
- Do not allow small children to play under or over the unit.
- Do not allow small children to reach inside the drawers or compartments without your supervision.
- Do not pull, push or drag the unit to move it for more than 1 feet. The unit must be lifted by at least 2 persons when moving in the same or adjacent rooms.
- Before moving the unit, make sure to secure or remove any object that is heavy or might fall off. Please note that lifting from the tabletop with too much weight on the product might lead to part damage/separation.
- When lifting the unit, use both hands and bend your knees, not your backs.
- When transporting the unit to places far away, protect and secure the unit to avoid damage in transit.
- Shall any part of the unit become defective during the warranty period, replacement parts might be available to you at no charge. Please refer to the last pages on this manual.
- The warranty does not extend to regular wear and tear, nor the manufacturer assumes liability for damages or consequences due to accidents, incorrect assembly, negligence, improper use, modifications, or not heeding the above warnings.

TECHNI MOBILI WARRANTY
DESKS/LAPTOP CARTS/FILE CABINETS: LIMITED 5-YEAR WARRANTY
TV Stand/Entertainment Center: 2 YEAR WARRANTY

RTA Products, LLC warrants to the Original Purchaser who acquired a new product from RTA Products or its authorized resellers that this product will be free from defects in its workmanship and materials, under normal use and service conditions, as described herein. "Defects" as used in this warranty, is defined as any imperfections that impair the use of the furniture or product. RTA Products LLC will replace any defective part, at its discretion, and without charge to the original purchaser other than the freight from the end consumer to RTA Products.

Replacement parts can only be supplied if parts are available. Items out of production may be unavailable. This warranty will be effective for the applicable time period beginning the date of purchase on your original sales receipt. RTA product's obligation under this warranty is limited to repairing or replacing products or parts as provided herein. This product has been designed for and is intended for office and home-office use only. This warranty is Original Purchaser's sole remedy for product defects, and this warranty does not extend to any product, or damage to any product, caused by or attributed to abuse or misuse, products used for commercial or rental purposes, use modifications of, or attachments to the product, and products or parts not used, maintained, or extended hereunder is in lieu of any and all other warranties, express or implied, including without limitations any implied warranty or merchantability or of fitness for a particular purpose. Please note, all desks made with PVC Laminate surface should not be exposed to direct sunlight, as it may damage the material. Damage of this nature is not covered under this warranty.

RTA Products will not be responsible for indirect, special, incidental or consequential damages. This warranty is limited to merchandise purchased in the Continental United States. Some States do not allow the exclusion or limitation of incidental or consequential damages, so the above limitations or exclusions may not apply to you. This warranty gives you specific legal rights. You may also have other rights that may vary from state to state.

RTA Products will advise you of the procedure to follow in making warranty claims. The following are the procedures for warranty claims:

- a. Call us Monday – Friday, from 9am-5pm (Eastern Time) at (866) 782-5520 to explain the defect and give your name, address and phone number. Please have ready the model number of our product, date and place of purchase. You can also write to us by e-mail to warranty@rtaproducts.com and include the same information.
- b. If we determine that replacement will remedy the situation, and in order to determine the extent or the cause of the defect, purchaser will need to send the part in question at purchaser's expense. Once we receive the part, we will examine it and determine whether the claim is valid (or not), and then proceed to send the replacement. We will ship the replacement at our expense.

FOR SEVERAL HELP OPTIONS INCLUDING REPLACEMENT PARTS ORDERS

VISIT: WWW.TECHNIMOBILI.COM



CLICK ON SUPPORT TAB



Scan QR Code to order replacement parts

OR EMAIL US: SUPPORT@RTAPRODUCTS.COM