

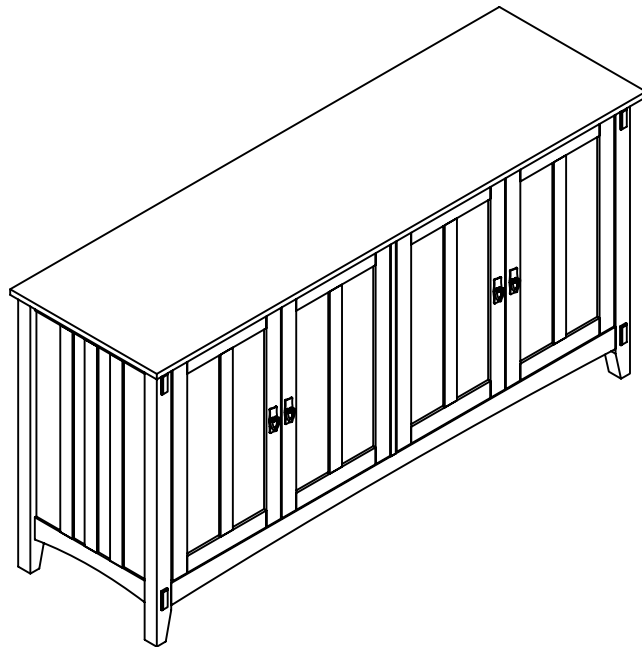
# HOME DECORATORS COLLECTION

1002960550 1002960551

SK18514 ARTISAN BUFFET 30"Hx60"Wx18"D

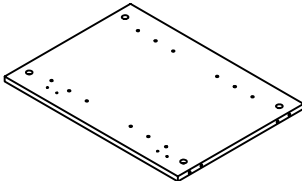
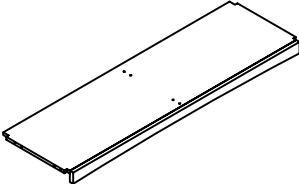
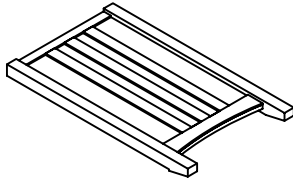
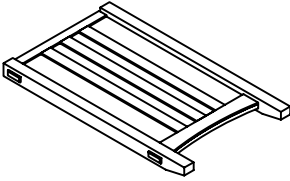
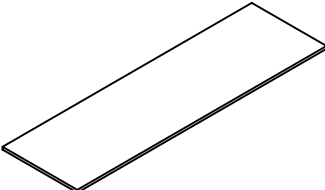
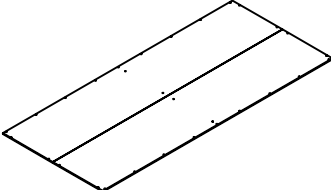
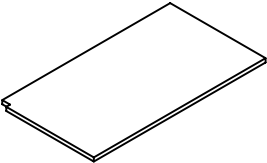
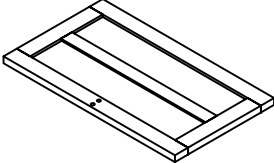
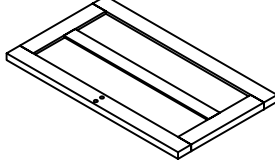
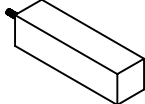
## ASSEMBLY INSTRUCTIONS


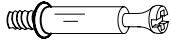





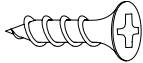
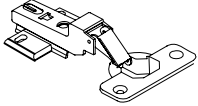





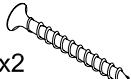




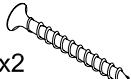




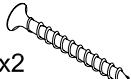
Made In China



Thank you for purchasing this quality product. Be sure to check all packing material carefully for small parts, which may have come loose inside the carton during shipment. Count all parts and material hardware, then compare with parts list to be sure all parts are present. If any parts are missing or damaged, phone, fax, or mail to our Customer Service Department for efficient and speedy service. Please indicate the model number and code letter of part(s) needed.

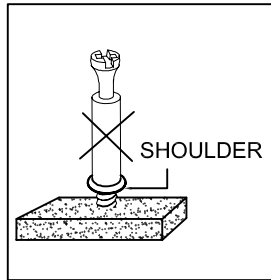
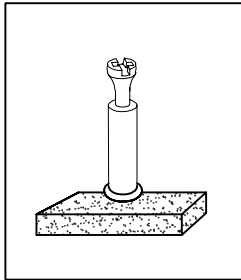
**IMPORTANT NOTE:** Follow instructions listed below in proper sequence as numbered to assure fast, easy and correct assembly.

<b>PARTS LIST</b>		
<b>A</b> 	<b>B</b> 	<b>C</b> 
PARTITION-1PC	BOTTOM PANEL-1PC	LEFT SIDE PANEL-1PC
<b>D</b> 	<b>E</b> 	<b>F</b> 
RIGHT SIDE PANEL-1PC	TOP PANEL-1PC	BACK PANEL-1PC
<b>G</b> 	<b>H</b> 	<b>I</b> 
ADJUSTABLE SHELF-4PCS	DOOR(1)-3PCS	DOOR(2)-1PC
<b>J</b> 		
FOOT-1PC		

<p><b>a</b></p>  <p>WOOD DOWEL-12PCS</p>	<p><b>b</b></p>  <p>CAM LOCK BOLT-12PCS</p>	<p><b>c</b></p>  <p>CAM LOCK-12PCS</p>					
<p><b>d</b></p>  <p>5/8"L ROUND HEAD SCREW-30PCS</p>	<p><b>e</b></p>  <p>HANDLE-4PCS</p>	<p><b>f</b></p>  <p>HANDLE BOLT-8PCS</p>					
<p><b>g</b></p>  <p>LONG PLASTIC COVER-8PCS</p>	<p><b>h</b></p>  <p>5/8"L FLAT HEAD SCREW-32PCS</p>	<p><b>i</b></p>  <p>HINGE-8PCS</p>					
<p><b>j</b></p>  <p>SHELF PIN-16PCS</p>	<p><b>ANTI-TIPPING HARDWARE PACKAGE</b></p> <table border="0"> <tr> <td data-bbox="660 1137 775 1294"> <p><b>1</b></p>  <p>x4 RECTANGLE METAL PLATE</p> </td> <td data-bbox="820 1137 935 1294"> <p><b>2</b></p>  <p>x2 1/2"L FLAT HEAD SCREW</p> </td> <td data-bbox="963 1137 1110 1294"> <p><b>3</b></p>  <p>x2 PLASTIC ANCHOR</p> </td> <td data-bbox="1139 1137 1222 1294"> <p><b>4</b></p>  <p>x2 PLASTIC BAND</p> </td> <td data-bbox="1267 1137 1414 1294"> <p><b>5</b></p>  <p>x2 1-1/2"L FLAT HEAD SCREW</p> </td> </tr> </table>		<p><b>1</b></p>  <p>x4 RECTANGLE METAL PLATE</p>	<p><b>2</b></p>  <p>x2 1/2"L FLAT HEAD SCREW</p>	<p><b>3</b></p>  <p>x2 PLASTIC ANCHOR</p>	<p><b>4</b></p>  <p>x2 PLASTIC BAND</p>	<p><b>5</b></p>  <p>x2 1-1/2"L FLAT HEAD SCREW</p>
<p><b>1</b></p>  <p>x4 RECTANGLE METAL PLATE</p>	<p><b>2</b></p>  <p>x2 1/2"L FLAT HEAD SCREW</p>	<p><b>3</b></p>  <p>x2 PLASTIC ANCHOR</p>	<p><b>4</b></p>  <p>x2 PLASTIC BAND</p>	<p><b>5</b></p>  <p>x2 1-1/2"L FLAT HEAD SCREW</p>			

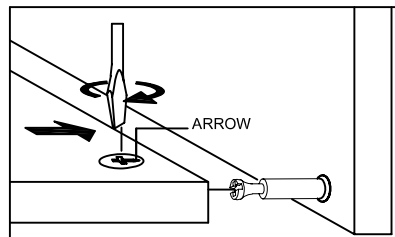
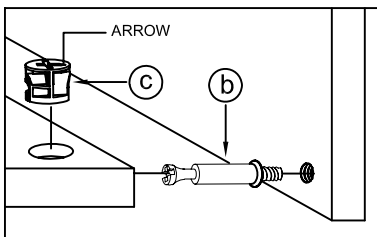
NOTE:THE SURFACE WITH THE STICKER IS THE BACK SIDE

NOTE: • UPON OPENING, THOROUGHLY CLEAN ALL WOOD SURFACES TO REMOVE DUST AND DIRT THAT MAY HAVE SETTLED ONTO THE FINISH DURING SHIPMENT. IN ORDER TO PREVENT DAMAGE DURING ASSEMBLY. PLEASE ASSEMBLE THIS ITEM WITH AT LEAST TWO PEOPLE.



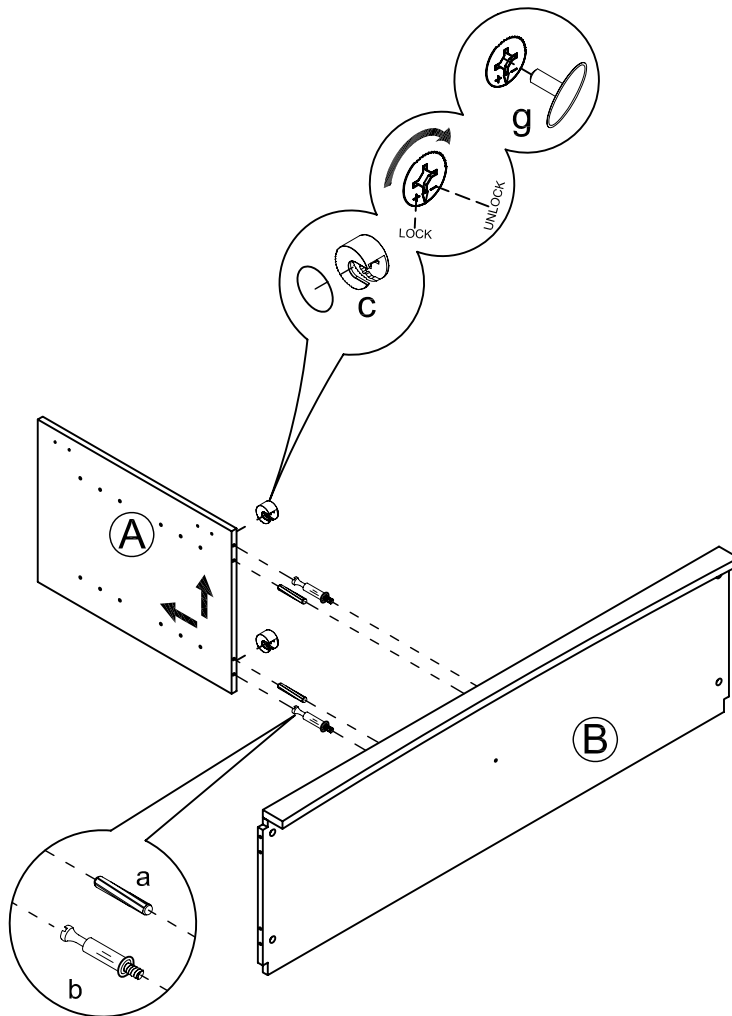
NOTE: TURN THE CAM-BOLT SCREWS UNTIL THEY ARE TIGHT, THE SHOULDER SHOULD BE AGAINST THE SURFACE OF THE PART.

## HOW TO USE THE CAM-TOOL



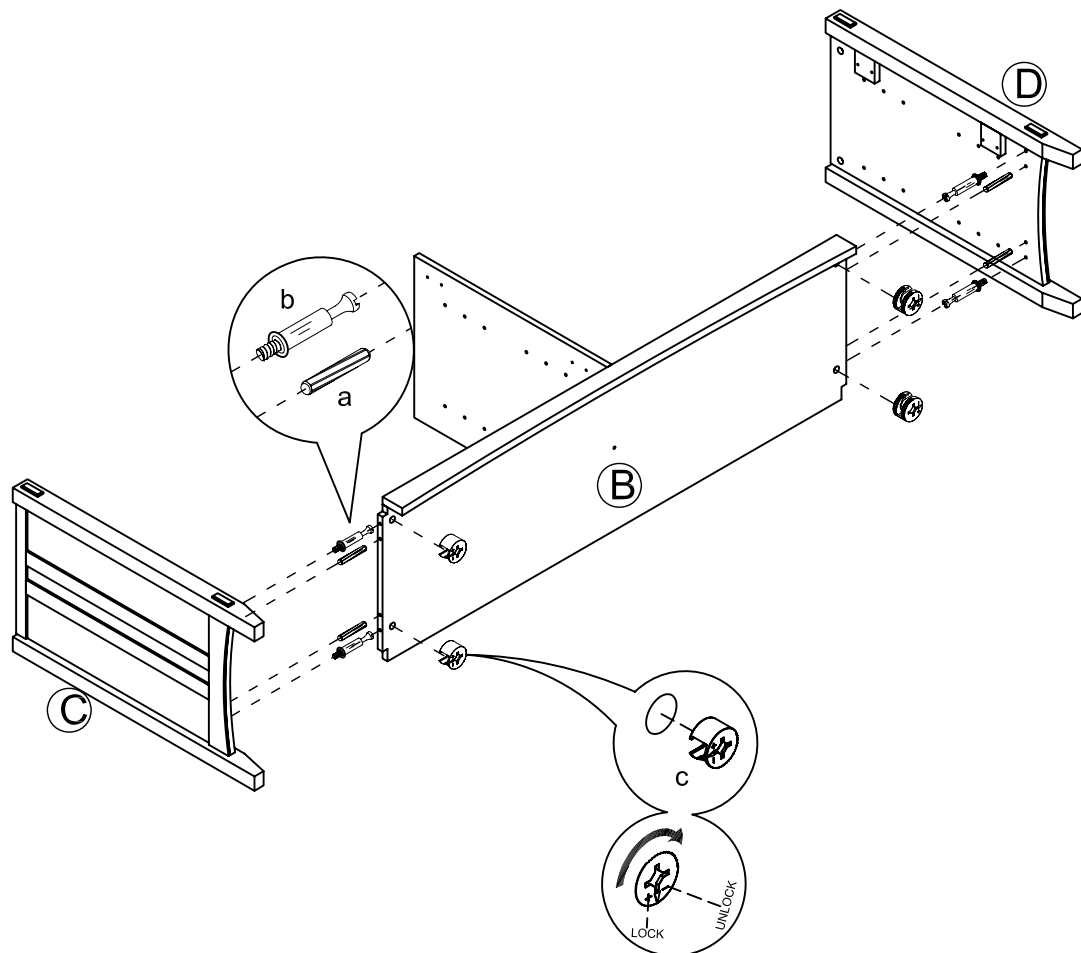
NOTE: • THE ARROWS ON THE HIDDEN CAM-LOCKS SHOULD POINT TO THE CAM-BOLTS.

# FIG 1



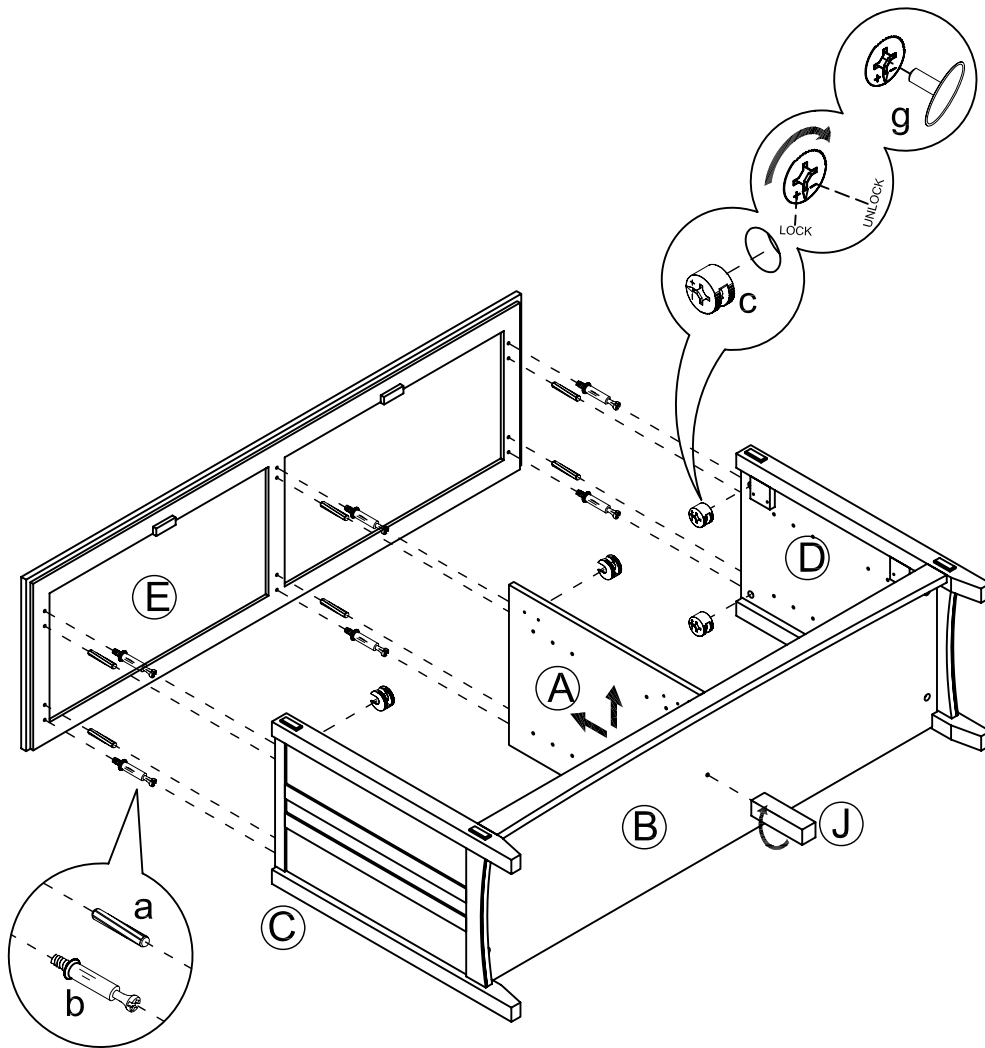
- INSTALL THE WOOD DOWEL (a) AND THE CAM LOCK BOLT (b) INTO THE BOTTOM PANEL (B) .
- JOIN THE BOTTOM PANEL (B) TO THE PARTITION (A) BY USING THE WOOD DOWEL (a) FIRST.
- ONCE JOINED, TIGHTEN CAM LOCK (c) ONTO CAM LOCK BOLT (b) USING PRE-DRILLED HOLES.
- COVER CAM HOLES WITH THE LONG PLASTIC COVER (g).

# FIG 2



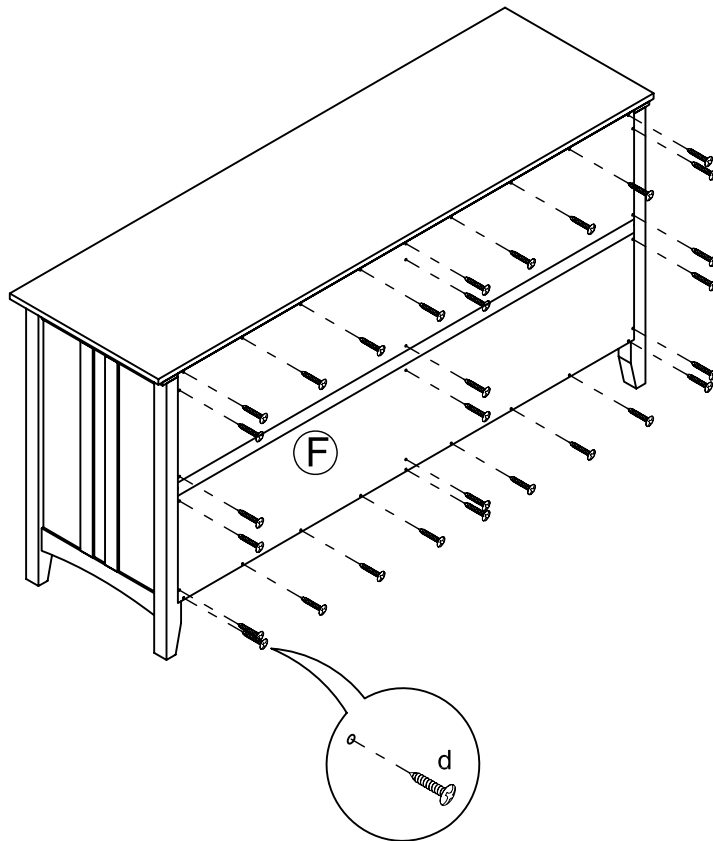
- INSTALL THE WOOD DOWEL (a) AND THE CAM LOCK BOLT (b) INTO THE LEFT SIDE PANEL (C) AND THE RIGHT SIDE PANEL (D) .
- JOIN THE LEFT SIDE PANEL (C) AND THE RIGHT SIDE PANEL (D) TO THE ASSEMBLED PART BY USING THE WOOD DOWEL (a) FIRST.
- ONCE JOINED, TIGHTEN CAM LOCK (c) ONTO CAM LOCK BOLT (b) USING PRE-DRILLED HOLES.

# FIG 3



- INSTALL THE WOOD DOWEL (a) AND THE CAM LOCK BOLT (b) INTO THE TOP PANEL (E) .
- JOIN THE TOP PANEL (E) TO THE ASSEMBLED PART BY USING THE WOOD DOWEL (a) FIRST.
- ONCE JOINED, TIGHTEN CAM LOCK (c) ONTO CAM LOCK BOLT (b) USING PRE-DRILLED HOLES.
- COVER CAM HOLES WITH THE LONG PLASTIC COVER (g).
- TIGHTEN THE FOOT (J) TO THE BOTTOM PANEL (B) AS SHOWN.

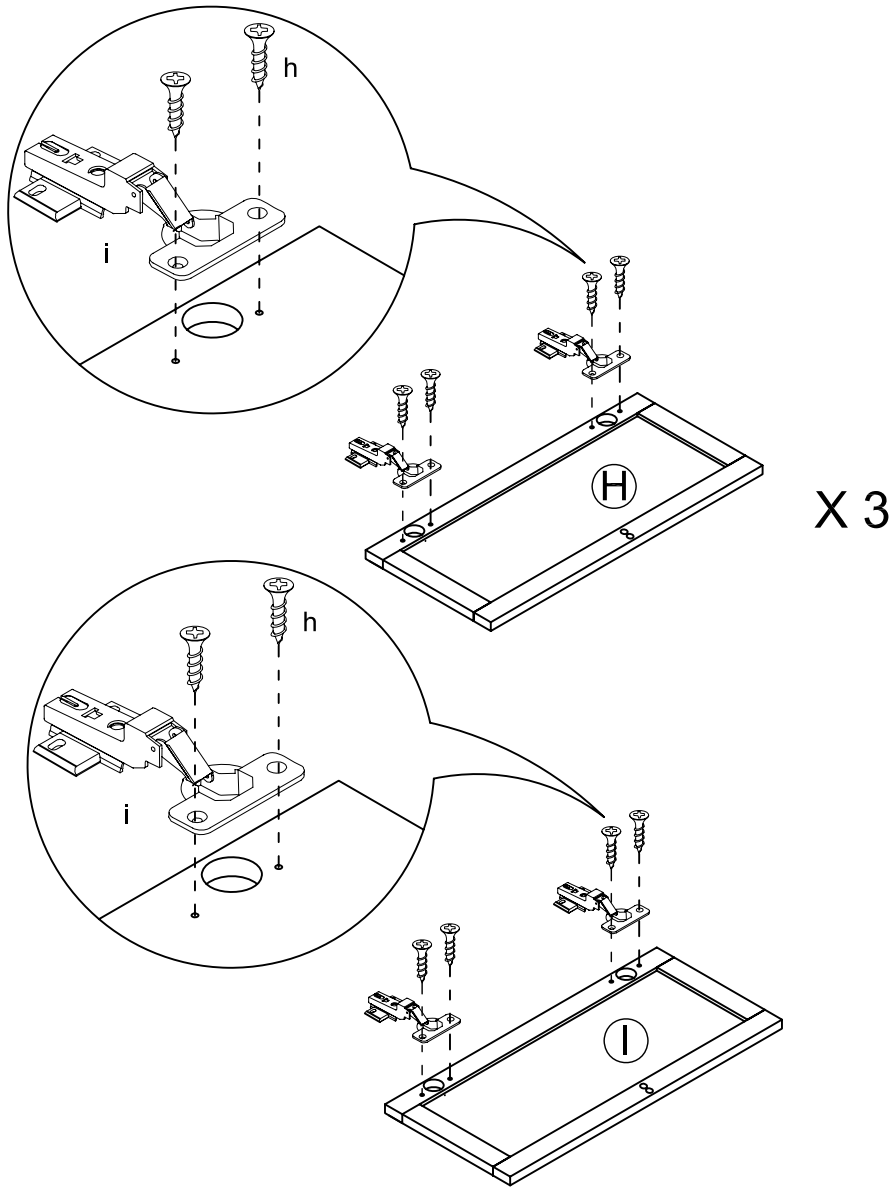
# FIG 4



- TIGHTEN THE RIGHT BACK PANEL (F) TO THE ASSEMBLED PART BY USING THE 5/8" ROUND HEAD SCREW (d).

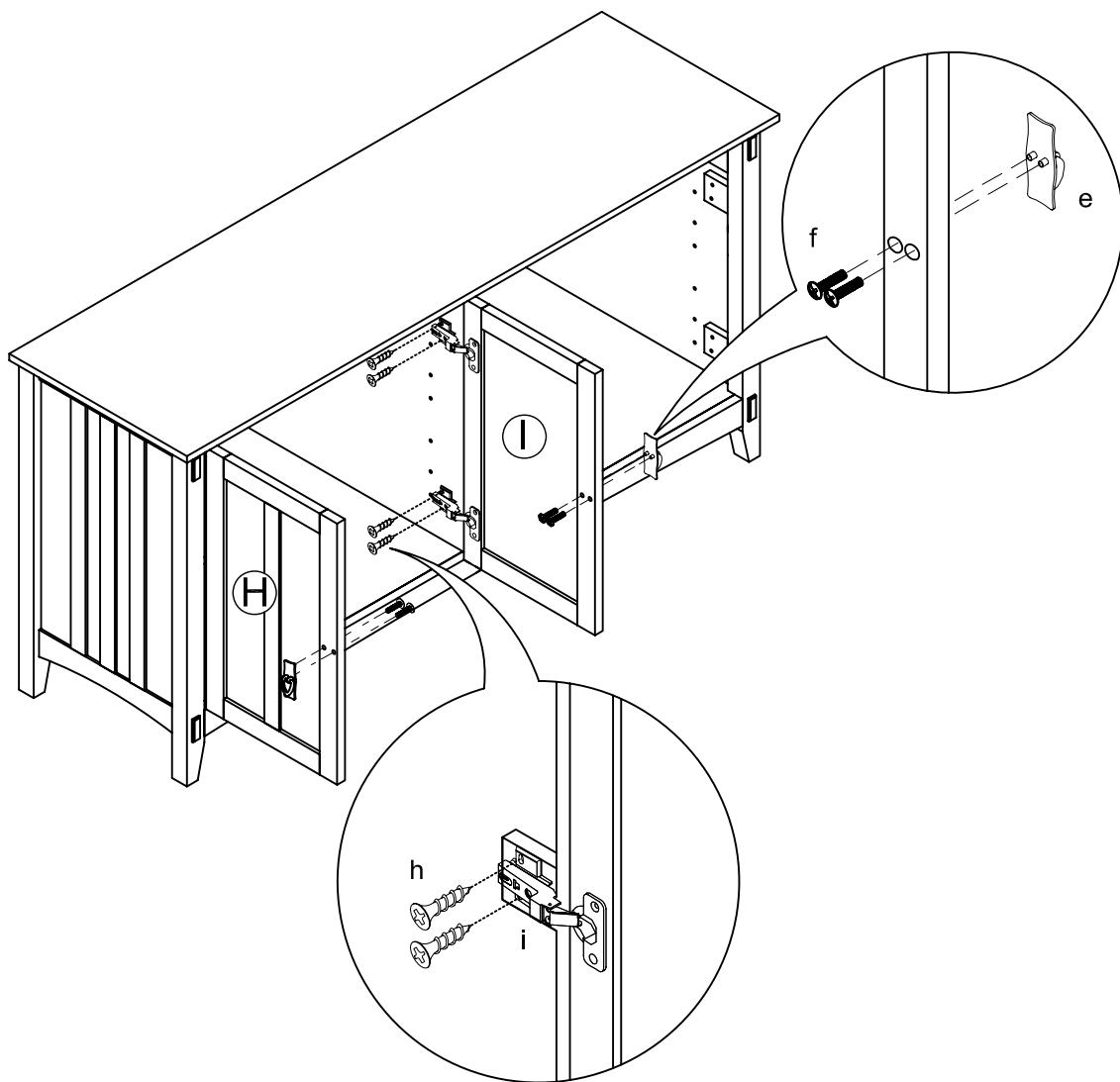


FIG 5



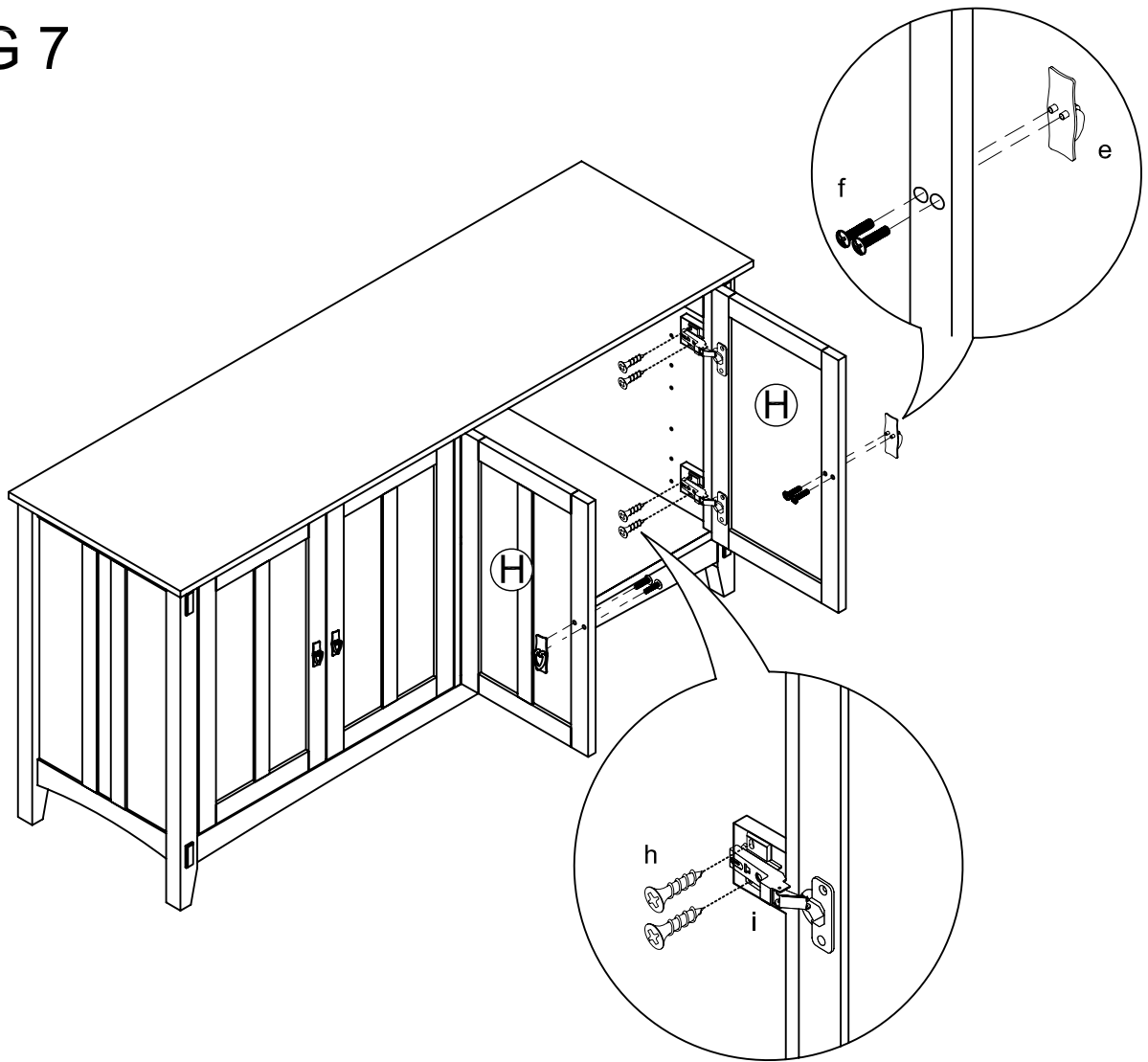
- TIGHTEN THE HINGE (i) INTO THE DOOR (1) (H) AND THE DOOR (2) (I) BY USING THE 5/8" L FLAT HEAD SCREW (h).

# FIG 6



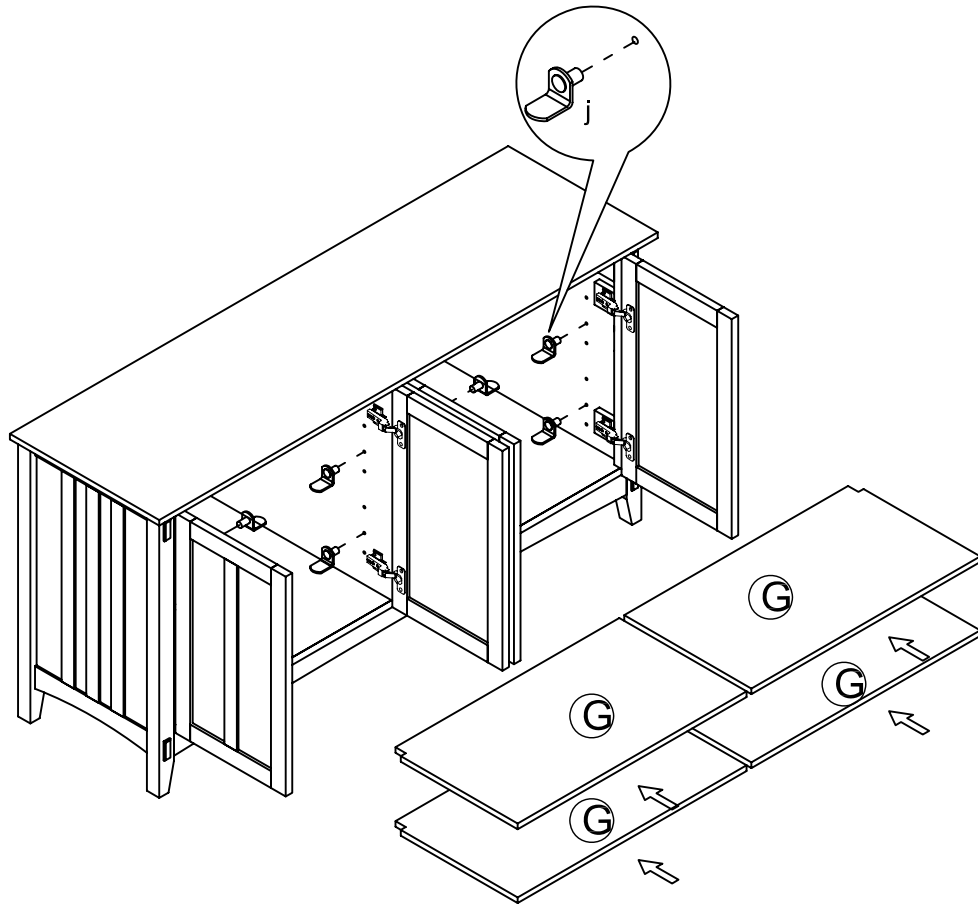
- ATTACH THE DOOR(1) (H) AND THE DOOR (2) (I) TO THE ASSEMBLED PART BY USING THE 5/8"L FLAT HEAD SCREW (h).
- TIGHTEN THE HANDLE (e) TO THE DOOR (1) (H) AND THE DOOR (2) (I) BY USING THE HANDLE BOLT (f).

FIG 7



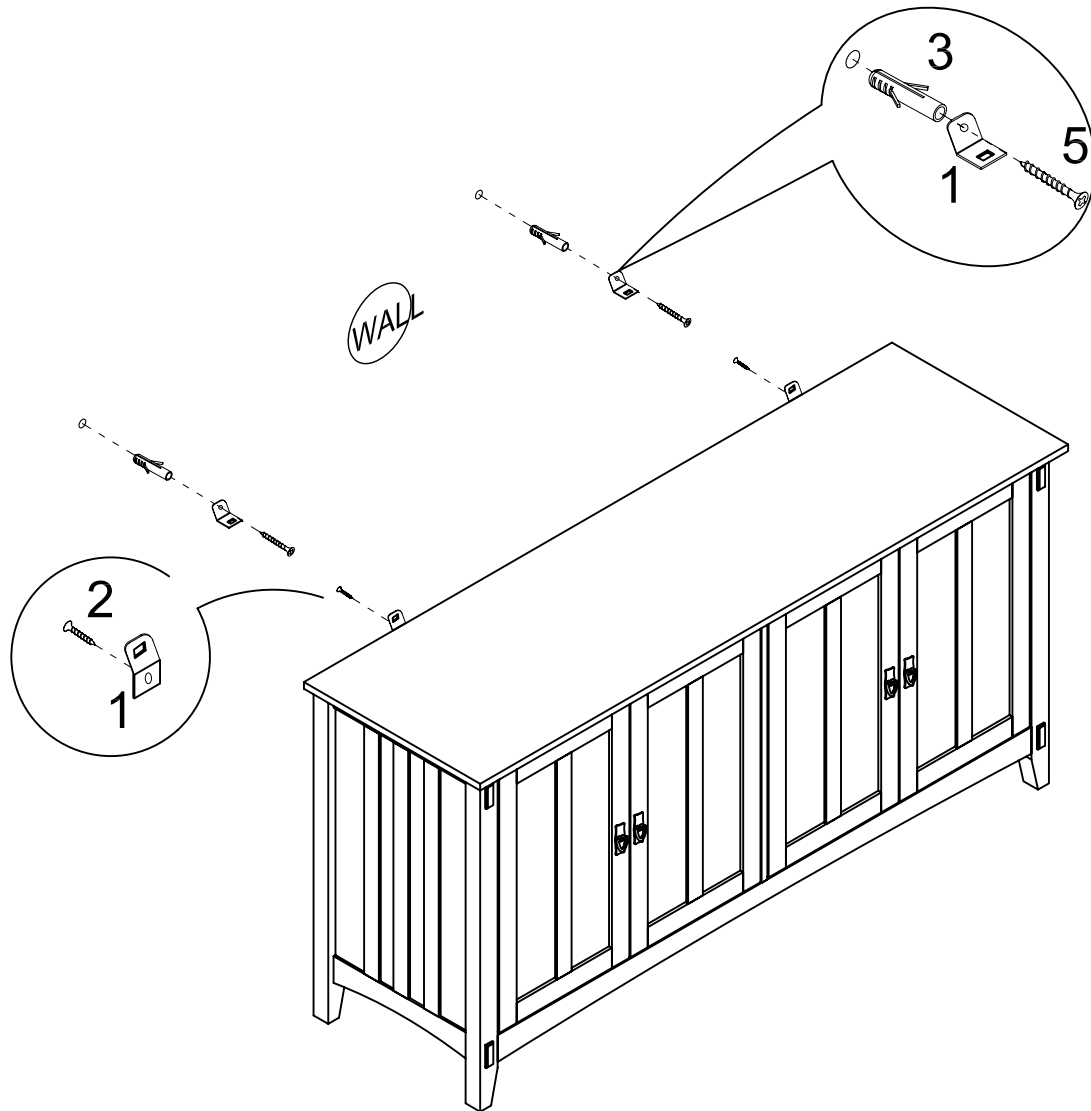
- ATTACH TWO DOOR(1) (H) TO THE ASSEMBLED PART BY USING THE 5/8" L FLAT HEAD SCREW (h).
- TIGHTEN THE HANDLE (e) TO THE DOOR (1) (H) BY USING THE HANDLE BOLT (f).

FIG 8



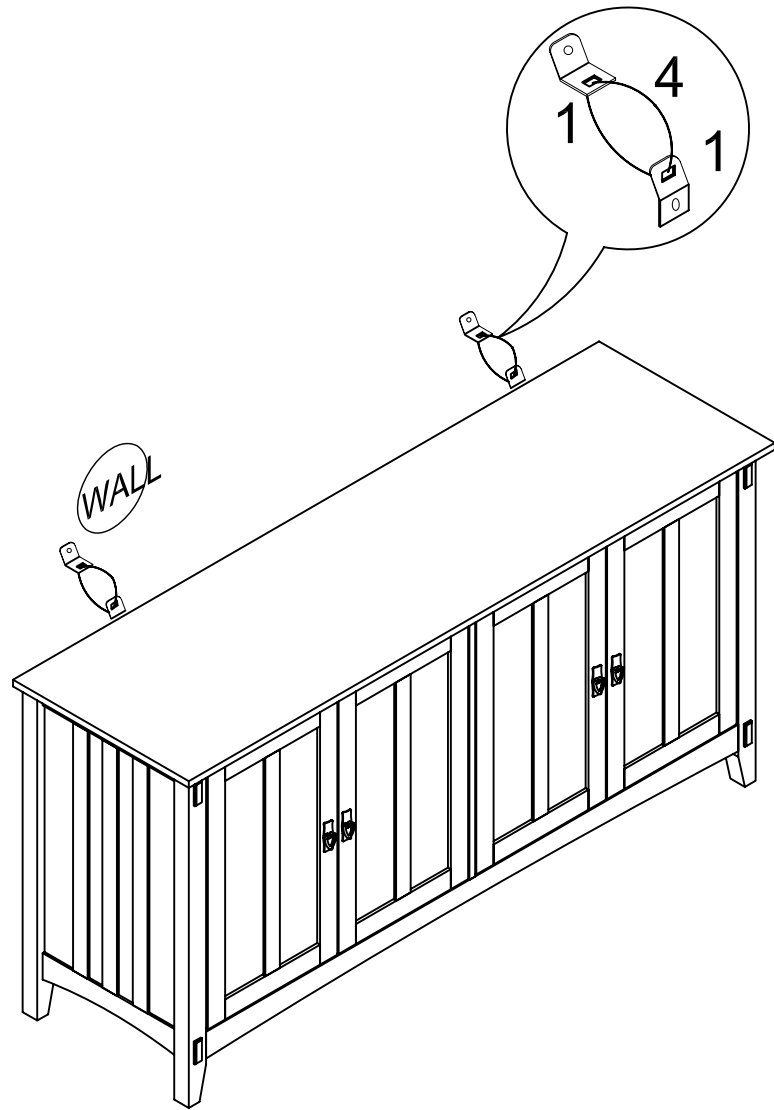
- PLACE THE SHELF PIN (j) INTO DESIRED POSITION AND PLACE THE ADJUSTABLE SHELF (G) ABOVE THE SHELF PIN (j).

# FIG 9



- TIGHTEN THE RECTANGLE METAL PLATE (1) TO THE REAR OF THE TOP PANEL (E) BY USING 1/2" FLAT HEAD SCREW (2).
- PLACE THE ASSEMBLED BUFFET AT THE DESIRED POSITION. MARK THE INSERTION POINTS FOR THE PLASTIC ANCHOR (3).
- USING THE PROPER HARDWARE FOR YOUR WALL TYPE, DRILL 1/4" HOLES INTO THE WALL.
- TIGHTEN THE RECTANGLE METAL PLATE (1) TO THE PLASTIC ANCHOR (3) BY USING THE 1-1/2" FLAT HEAD SCREW (5).

FIG 10



- USING THE PLASTIC BAND (4) CONNECT TWO RECTANGLE METAL PLATES (1).