

REPAIR SHEET

BRAND RYOBI		DESCRIPTION 40 Volt Brushless Snow Blower
MODEL NO. RY40809VNM	MFG. NO. 108957001	

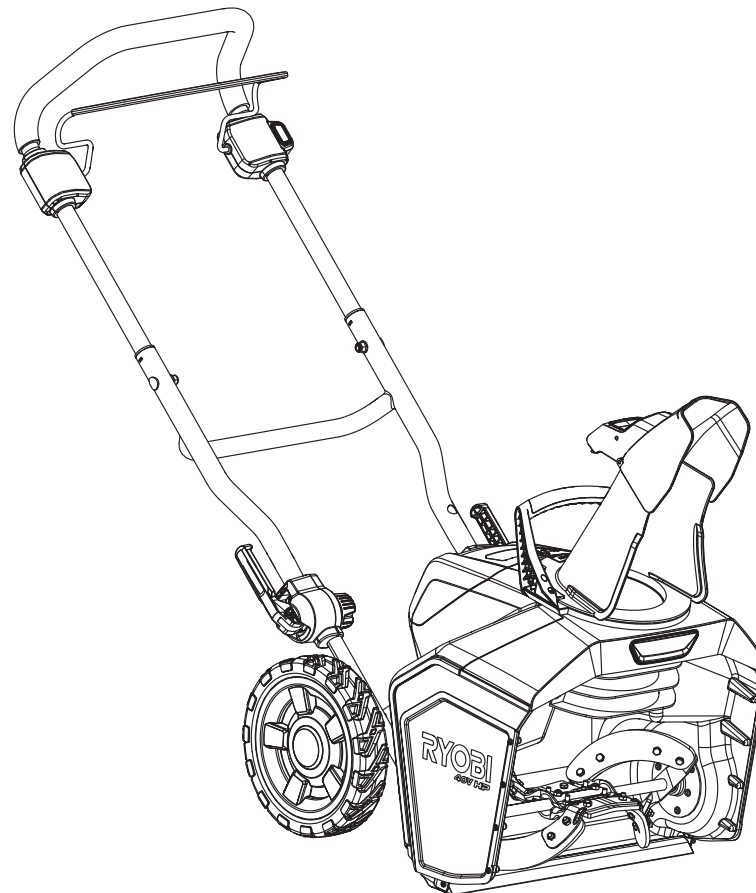

TECHTRONIC INDUSTRIES POWER EQUIPMENT

P.O. Box 1288, Anderson, SC 29622 ■ 1-800-525-2579 ■ www.ryobitools.com

9-10-21 (Rev:01)

The model number and manufacturing location will be found on a label attached to the product. Always mention this information in all communications regarding this product and when ordering parts.

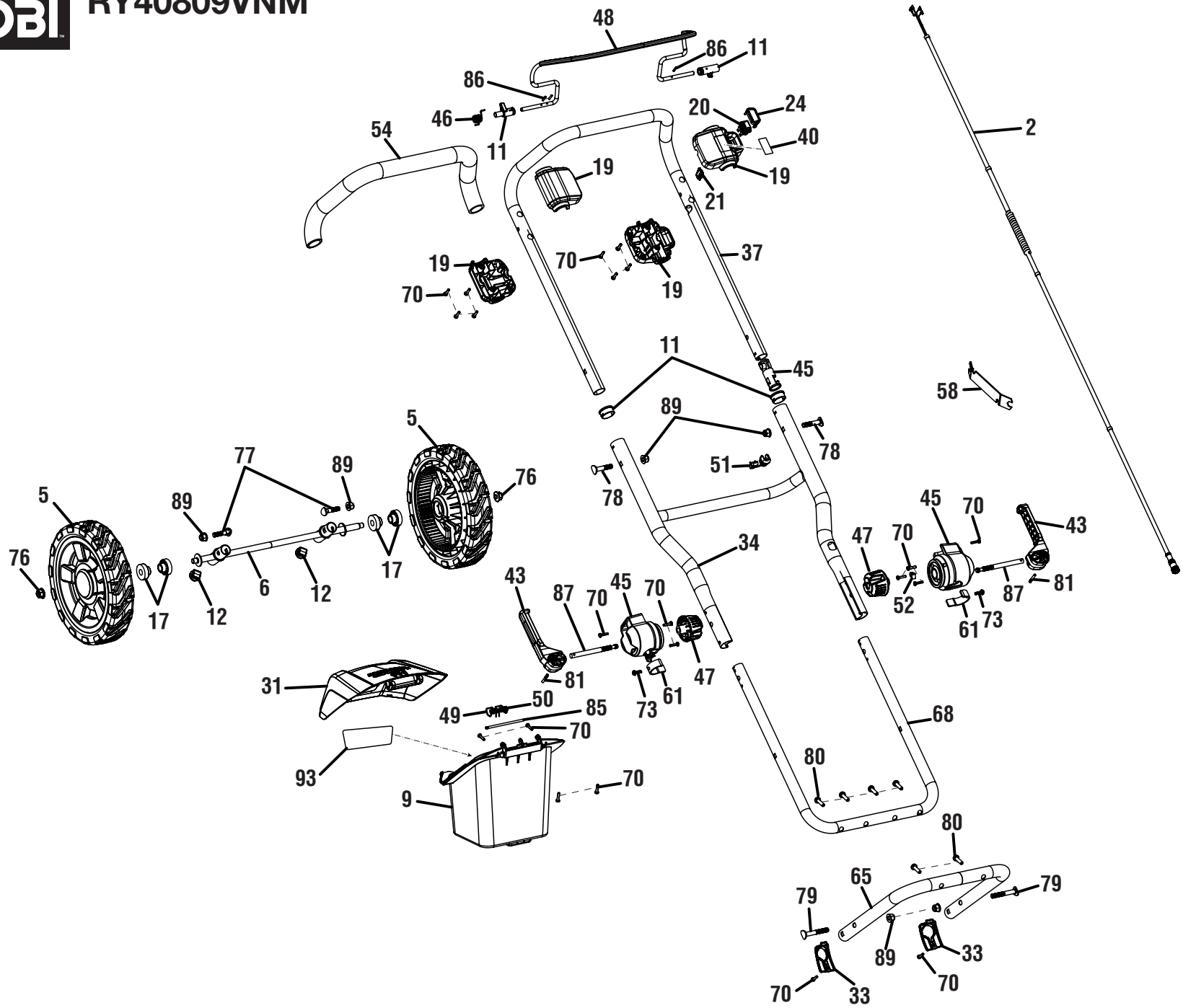

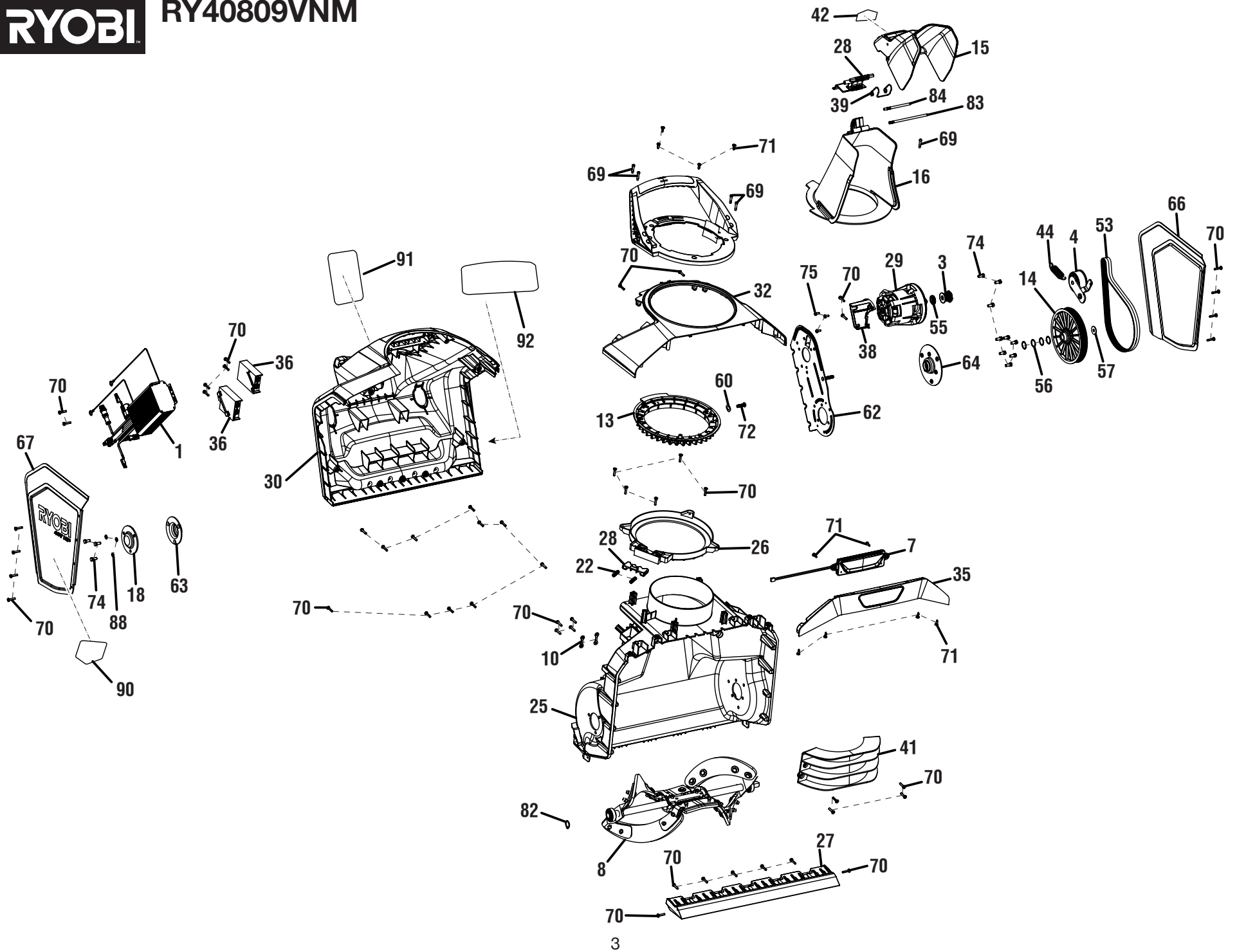



RY40809VNM

PARTS LIST

KEY NO.	PART NO.	DESCRIPTION	QTY.
1	280400010	Motor Controller	1
2	292316001	Electrical Wire Assembly	1
3	311275002	Motor Pulley	1
4	315038001	Sheet Metal Bracket	1
5	317159001	10 in. Wheel	2
6	317569001	Lower Support Tube and Axle Assembly	1
7	317593001	LED Light Assembly	1
8	317598001	Auger Assembly	1
9	205721001	Battery Box With Label	1
10	513211003	Hold-Down Tab	2
11	205717001	Actuator and End Bushing Assembly	1
12	529330001	Plug for 22 mm Steel Tube End	2
13	537730002	Chute Gear	1
14	537737001	Auger Pulley	1
15	205720001	Chute Deflector With Label	1
16	537741001	Upper Chute	1
17	538520001	Wheel Bushing	4
18	539292001	Auger Bearing Cover Plate	1
19	205711001	Handle Latch Housing Assembly With Label	1
20	760653001	Push Button Switch	1
21	760595004	Micro Switch	1
22	699472001	Compression Spring	2
23	205716001	Chute Rotation Assembly	1
24	543252001	Safety Button	1
25	543253001	Lower Body	1
26	543255001	Chute Rotation Platform	1
27	543334001	Scraper Blade	1
28	205714001	Manual Chute Adjust Detent and Deflector Latch Assembly	1
29	742515002	Motor	1
30	205718001	Rear Cover With Labels	1
31	543373001	Battery Cover	1
32	543384001	Top Cover	1

KEY NO.	PART NO.	DESCRIPTION	QTY.
33	205713001	Tube Exit Cover Assembly	1
34	699396001	Lower Handle Tube	1
35	543390001	Front Cover	1
36	205715001	Controller Mounting Assembly	1
37	699395001	Top Handle Tube	1
38	543392001	Motor Mounting	1
39	697882002	Deflector Latch Spring	1
40	941263004	Starting Instructions Label	1
41	543761001	Lower Chute Neck	1
42	941588400	Chute Icon Label	1
43	543886001	Cam Latch	2
44	697873001	Belt Tensioner Spring	1
45	205712001	Knuckle and Cable Gland Assembly	2
46	695036002	Torsion Spring	1
47	543990001	Knuckle Knob	2
48	695004013	Metal Wire Trigger	1
49	699476001	Torsion Spring For Battery Cover (Left)	1
50	699476002	Torsion Spring For Battery Cover (Right)	1
51	544080001	Cable Grommet	1
52	544965001	Wire Clamp	1
53	563939002	Belt	1
54	566049001	Rubber Foam Tube	1
55	614164001	Motor Pulley Spacer	1
56	635486001	Flat Washer (ID15.1 x OD19 x 0.5t)	4
57	636191001	Flat Washer	1
58	638015001	Combination Wrench	1
59	638892001	Flat Washer	6
60	638909005	Wave Washer	1
61	656179001	Handle Limiter Spring	2
62	658275002	Motor Mounting Plate	1
63	658276001	Auger Bearing Retainer Plate (Non-Drive Side)	1
64	658396001	Auger Bearing Retainer Plate (Drive Side)	1



RY40809VNM

PARTS LIST (cont.)

KEY NO.	PART NO.	DESCRIPTION	QTY.
65	659897001	Bracing Tube	1
66	659898001	Left Side Cover	1
67	205719001	Right Side Cover With Label	1
68	659901001	Mount Body Tube	1
69	660208050	Screw (M4 x 20 mm, Pan Hd.)	5
70	660466001	Screw (M4 x 18 mm)	70
71	660608001	Screw (M4 x 12 mm)	10
72	660697002	Screw (M6 x 20 mm, Torx Hd.)	1
73	660918003	Screw (M5 x 16 mm, T25 Torx Hd.)	2
74	660927008	Bolt (M5 x 12 mm, Hex Hd.)	12
75	661861004	Screw (M4 x 0.7 mm)	3
76	662082001	Lock Nut	2
77	662104002	Screw (M8 x 36 mm)	2
78	662104005	Screw (M8 x 42 mm)	2
79	T662339001	Screw (M8 x 60 mm)	2
80	664004003	Screw (1/4"-15 x 22 mm, T30 Torx Pan Hd.)	6

KEY NO.	PART NO.	DESCRIPTION	QTY.
81	673874001	Cam Lever Dowel	2
82	673923001	C-Ring	1
83	673981001	Deflector Pin	1
84	673990001	Latch Pin	1
85	674253001	Battery Cover Pin	1
86	674290001	Spring Pin (3 x 16 mm)	3
87	674294001	Dual Thread Pin	2
88	678287001	Flat Washer (ID5.20 x OD10 x 0.8t)	3
89	678774012	Flange Lock Nut (M8)	6
90	941641001	CPSC Cut Finger Label	1
91	941263002	Icons and EN/FR Danger Label	1
92	941263001	Data/Caution/SP Danger Label	1
93	941263003	Battery Notice Label	1
	Not Shown:		
	998000586	Operator's Manual	



RY40809VNM

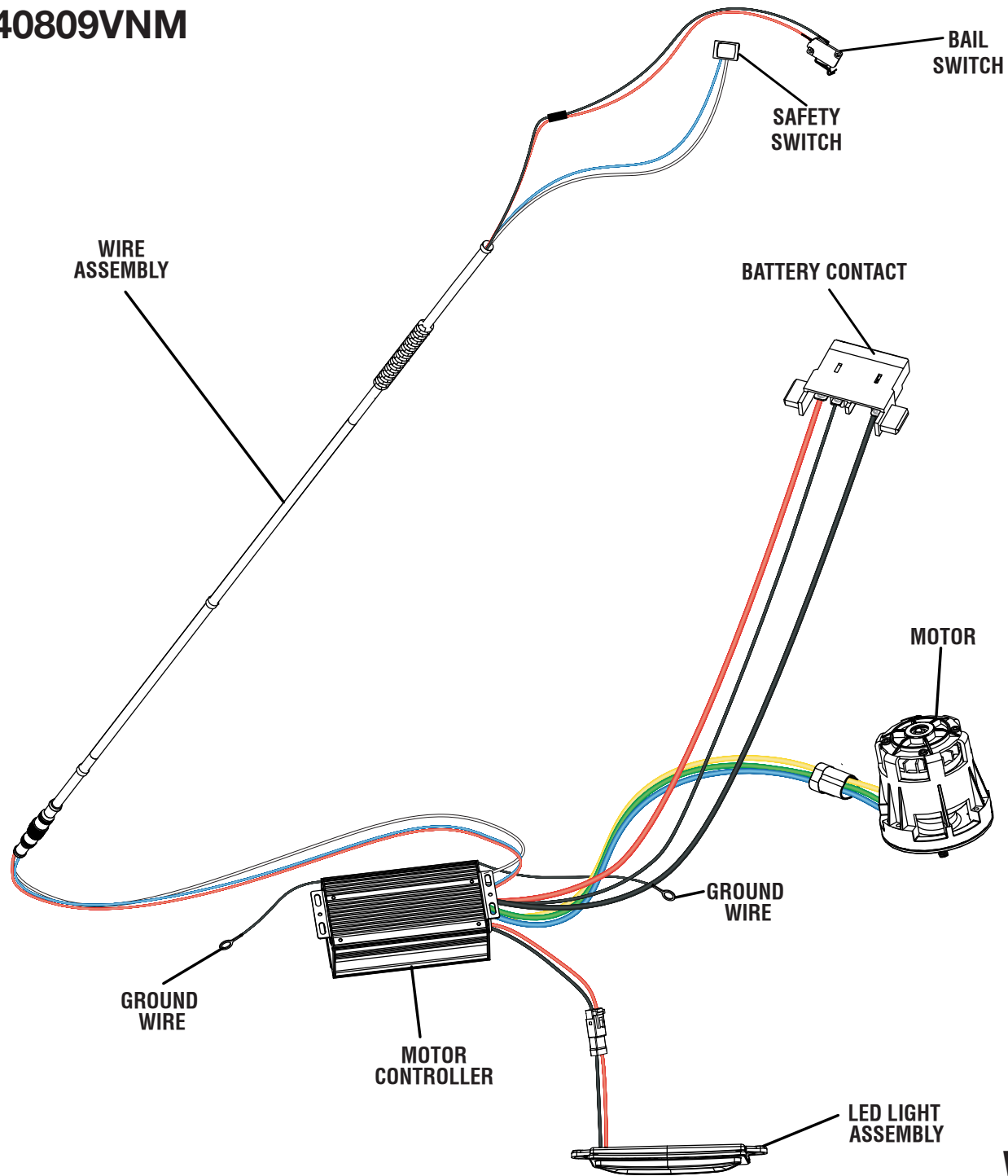

WIRING DIAGRAM