

# Rigid Board Installation Builder's Guide



## PART 1 - ABOVE GRADE



For New and Existing Low-Rise Residential and Commercial Construction

## Contents

<b>3</b>	<b>Part 1</b>	<b>Introduction</b>
3		Products
4		Applications
5		Product Availability
5		Packaging
5		Material Storage
5		Warranty
<b>6</b>	<b>Part 2</b>	<b>Installation</b>
6	Exterior	With Sheathing
7		Open Stud Assembly
8		Typical Fastening Patterns - With Sheathing
10		Typical Fastening Patterns - Open Stud Assembly
14		Typical Joint Taping
15	Interior	Acoustic Partition Walls
15		Maintaining Air Barrier Continuity
16		Standard Ceiling
17		Cathedral Ceiling
18	Fenestrations	Flanged Window
22		Non-Flanged Window
26		Swing Door
30		Penetrations
31		Attic Access Hatch
32		Repairs
<b>34</b>	<b>Part 3</b>	<b>Physical Properties and Testing</b>
<b>36</b>	<b>Part 4</b>	<b>Product Range</b>

## Products

SilveRboard® product line is a rigid, flat-sheet insulation material made from Expanded Polystyrene (EPS), covered with a layer of polypropylene reflective lamination on both sides. When installed with an air gap between SilveRboard® and the exterior cladding, the film is able to reflect radiant energy away from the surface keeping heat out during the summer and keeping heat in during the winter.

### SilveRboard®

SilveRboard® is the original and most versatile line due to the various numbers of available configurations, ranging in compressive and flexural strengths, densities and thicknesses. Although SilveRboard can fulfill many roles, it is best suited for ceiling applications.

### SilveRboard® XS

SilveRboard® XS has been specifically engineered with the laminated surfaces perforated in order to allow the passage of water vapor. The product is identical in performance to the original SilveRboard® with the difference being the water vapor permeance which increased to 3.48 US Perms (217 ng/Pa\*s\*m<sup>2</sup>).

### SilveRboard® UC (Under Concrete)

SilveRboard® UC has compressive strength of 35 psi making it the ideal solution for below grade applications. The reflective lamination on both sides provides added strength, reducing job site breakage and cracking during construction. It can also serve a vapor barrier when taped sealed.

### SilveRboard® Acoustic

SilveRboard® Acoustic is a low density variant designed to provide improved acoustic performance to various assemblies with a rating of STC 19 & IIC 70. It can be used for walls, floors, ceilings in bathrooms, laundry rooms, bedrooms, home theaters and quiet rooms.

### SilveRboard® Graphite XS

SilveRboard® Graphite XS is a high performing rigid foam insulation. It uses expanded polystyrene (EPS) base material with embedded carbon “graphite” particles which increase the thermal performance of the insulation. The graphite EPS beads reflect radiant heat energy similar to the effect of a mirror and increase the material's ability to resist the flow of heat. When taped and used as continuous exterior insulation, a separate weather barrier is not required.

## Applications

SilveRboard® products are suitable for a variety of applications including residential, agricultural, commercial and industrial sectors.

Applications	SilveRboard®	SilveRboard® XS	SilveRboard® UC	SilveRboard® Acoustic	SilveRboard® Graphite XS
Exterior above grade wall	✓	✓	✓		✓
Interior acoustic partition				✓	
Attic ceiling	✓				
Cathedral ceiling	✓				
Exterior foundation wall	✓		✓		
Interior foundation wall	✓	✓	✓		✓
Above concrete slab			✓		
Below concrete slab			✓		
Frost wall			✓		
Radiant floor heating			✓		
<i>Ideal</i>	✓				
<i>Acceptable</i>	✓				

## Product Availability

To meet the unique construction needs of all the parties involved in a construction project we offer a broad and versatile range of products, both conventional and innovative, for every kind of building insulation application. Special orders are available depending on the project scope and needs.

## Packaging

- For all board sizes, bundle size is 30" (762mm) in height with corresponding board dimensions for length and width.
- Number of boards per bundle varies with thickness, ranging from 8-60 boards.
- Weight of bundle varies with density of board, ranging from 80-200 lb.
- All SilverBoard® bundles come wrapped in UV protected plastic film.
- Each bundle includes a label with a product code, size of boards, R-value of given board, number of boards and manufacturing date.

The product code is printed on the bundle label. An example; SKU code - **SB12S2004S** can be read as follows (see Product Range for all available products):

- (SB) indicates SilverBoard®
- (12) indicates 12 psi (82.7 kPa) for compressive strength
- (2) indicates thickness of 2" (51mm)
- (4) indicates 4'x8' (1219x2438 mm) board size

## Material Storage

SilverBoard® products should be secured during storage and placement. The boards should be covered with a light-colored opaque tarp if stored outdoors for longer than two weeks to reduce excessive moisture intake. EPS should not be exposed to hydrocarbons, e.g. petroleum based solvents such as gasoline, diesel fuel, concrete curing compounds, coal tar pitch and asphalt/mastic compounds.

## Warranty

Amvic supports building owners, designers and contractors by offering a 20-year, limited thermal warranty on SilverBoard® product line. This warranty is available to the building owner at the time the building is completed and is transferable to any subsequent owner during the 20-year period.

## Exterior

For this type of application SilverBoard® Graphite XS is recommended.

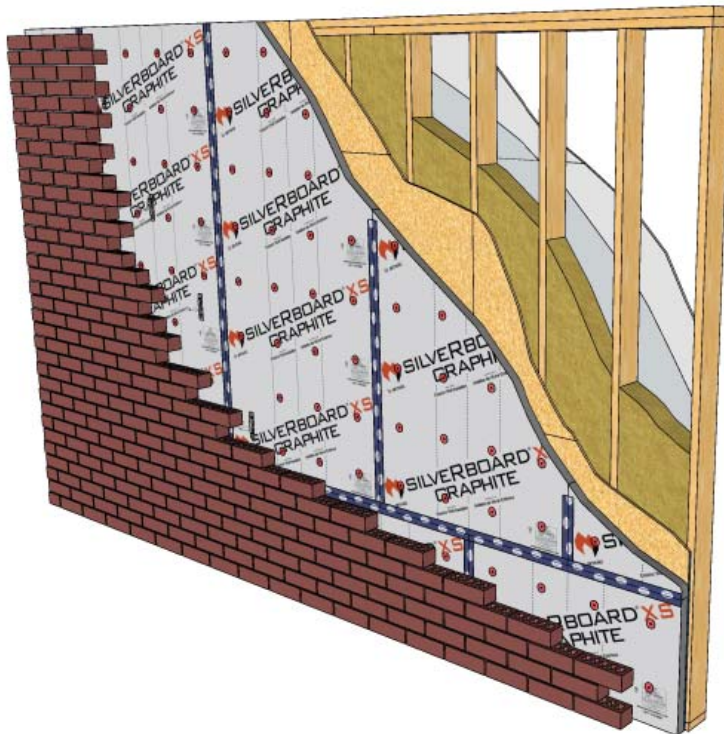

Typical wall assembly with SilverBoard Graphite XS as continuous insulation and brick veneer cladding

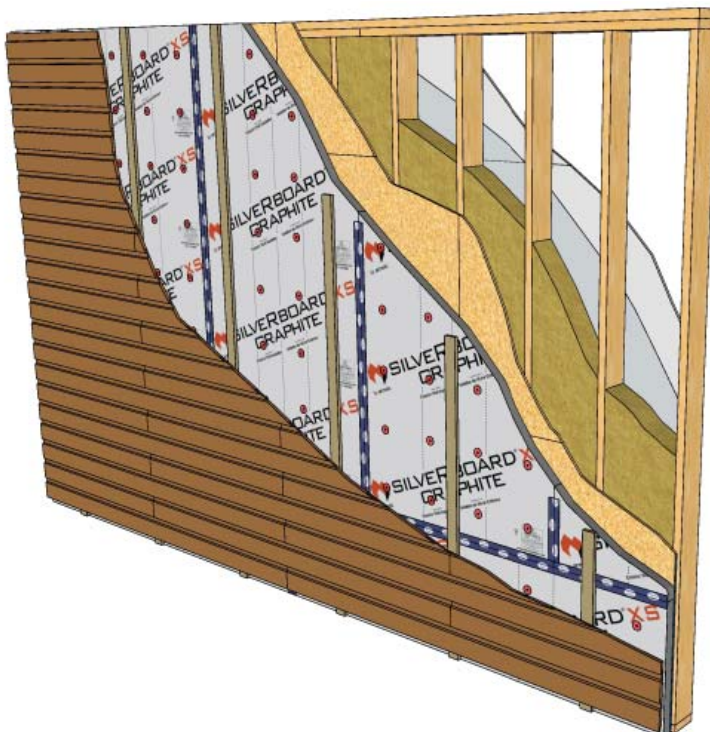

Typical wall assembly with SilverBoard Graphite XS as continuous insulation and siding

### With Sheathing

- Measure the height and width of the wall before starting each wall facing is to determine best board layout.
- Installation should start with a full board placed at the bottom corner at the front face of the building while the cuts and joints are left for the upper portions.
- It is beneficial to stagger the joints of the sheathing and that of the rigid board insulation to reduce gaps and improve air tightness.
- All seams should be taped using code approved sheathing tape.
- Gaps should be sealed with low expansion foam, caulking or tape depending on the size.

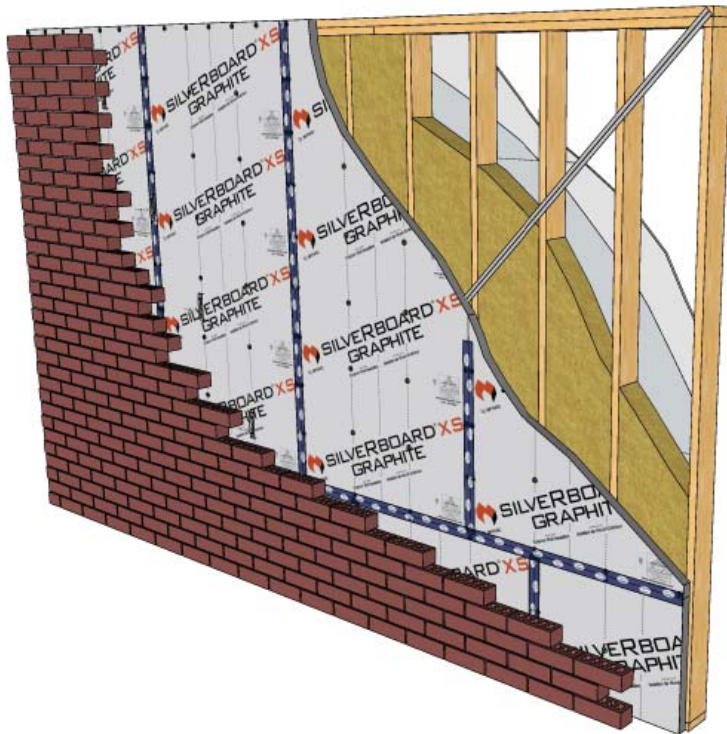

Typical open stud wall assembly with SilverBoard Graphite XS as continuous insulation and brick veneer cladding

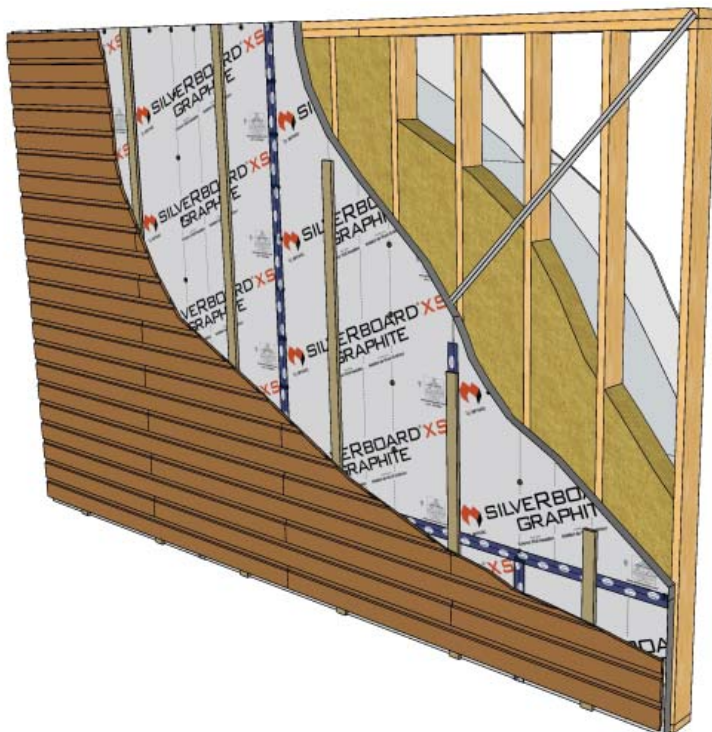

Typical open stud wall assembly with SilverBoard Graphite XS as continuous insulation and siding

## Open Stud Assembly

*\*This type of installation could require the use of corner and/or wind bracing, check local code guidelines and structural design.*

- For open stud wall assemblies, it is recommended to use vertical orientation due to the stud center line marking on the boards (horizontal is also possible).
- Placement of boards should be started at the bottom at one of the corners with a full board if possible leaving cuts and joints towards upper portion of the wall.
- For corner areas with shear bracing, full boards should be used to cover both the reinforcing board and the first one or two vertical studs in order to provide the best layout for the continuous insulation.
- All seams should be taped using compatible sheathing tape.
- Gaps should be sealed with low expansion foam, caulking or tape depending on the size.

### Typical Fastening Patterns - With Sheathing

- For applications of SilverBoard® directly on the face of sheathing cap nails, cap staples and assembled fasteners can be used.
- Allow for a minimum of 1" (25mm) of fastener length, longer than the total thickness of the insulation board e.g. for 1" (25mm) SilverBoard® Graphite XS + 1" (25mm) = 2" (51mm) nail/staple or screw.
- Sheathing provides sufficient backing for fasteners, allowing for flexibility in the nailing pattern and eliminating the need to fasten into structural members.

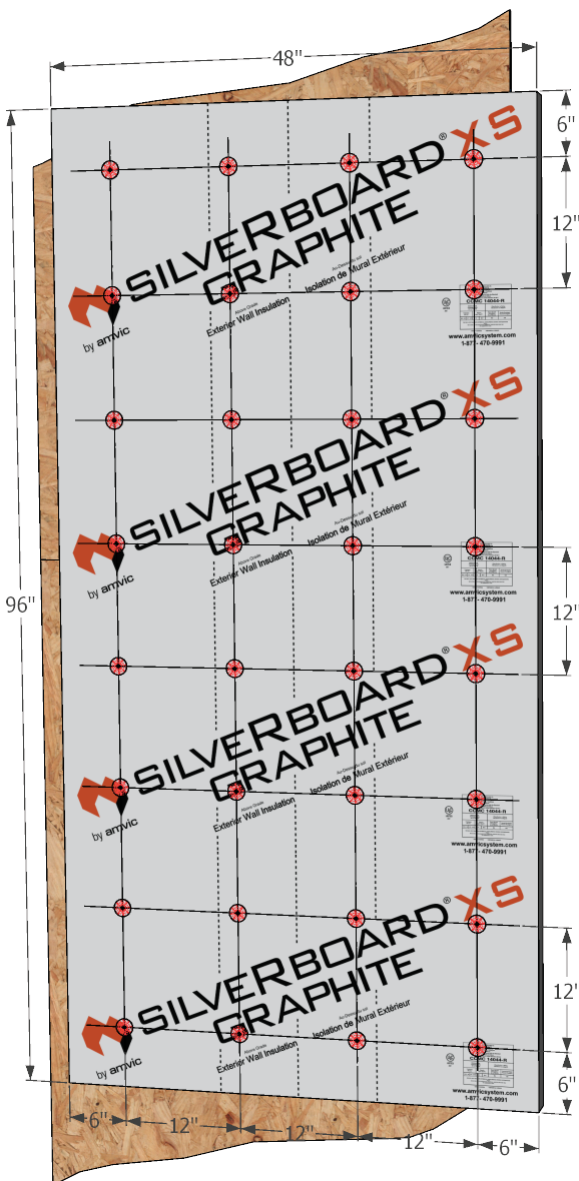

Vertical nailing Pattern A - 32 assembled fasteners

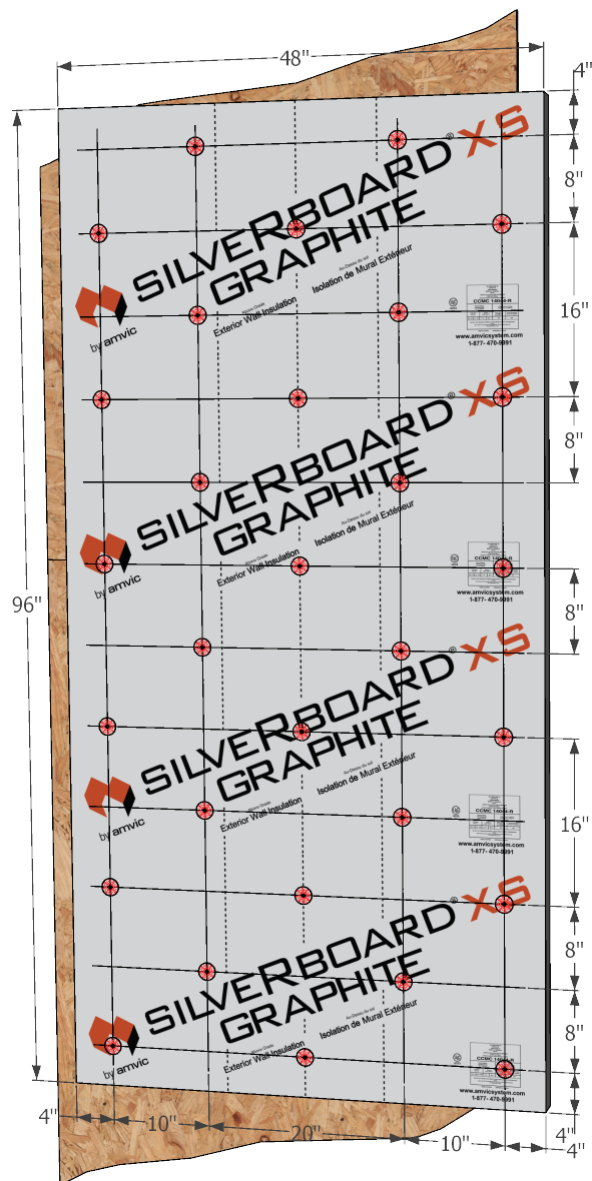

Vertical nailing Pattern B - 30 assembled fasteners



- Regardless of the chosen configuration the fasteners should not be more than 18" (457mm) apart around the edges of the boards or 24" (610mm) at the center.
- Brick ties and strapping are considered fasteners, do not duplicate.
- Do not over-torque fasteners.
- Brick ties must fasten through the insulation to the substrate.

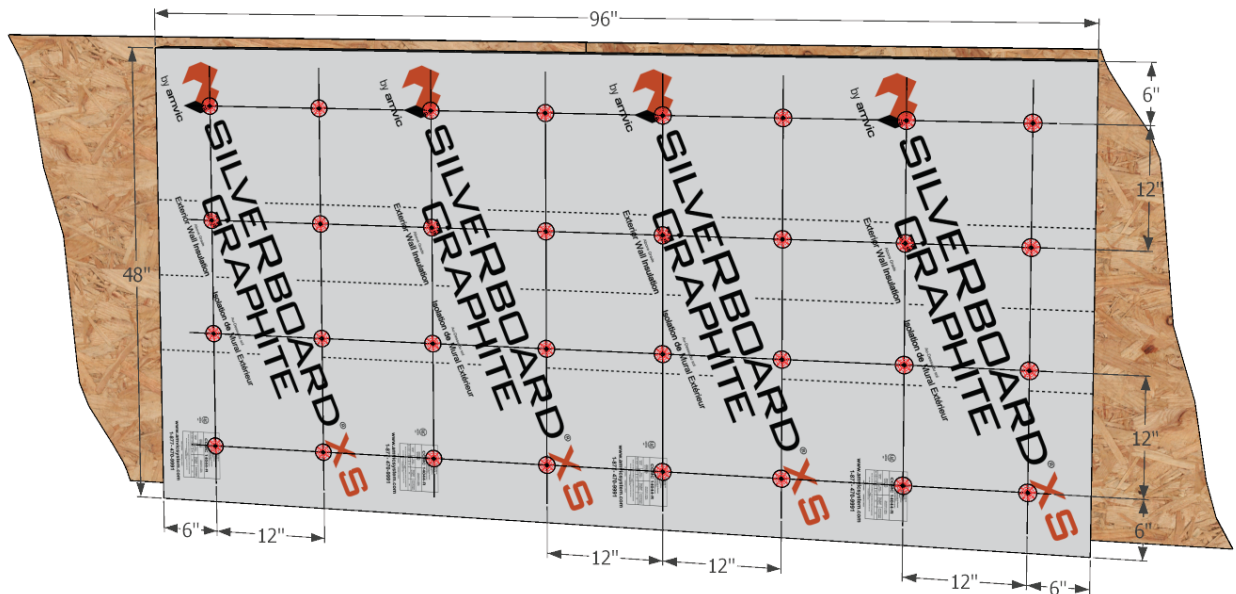

Horizontal nailing Pattern A - 32 assembled fasteners

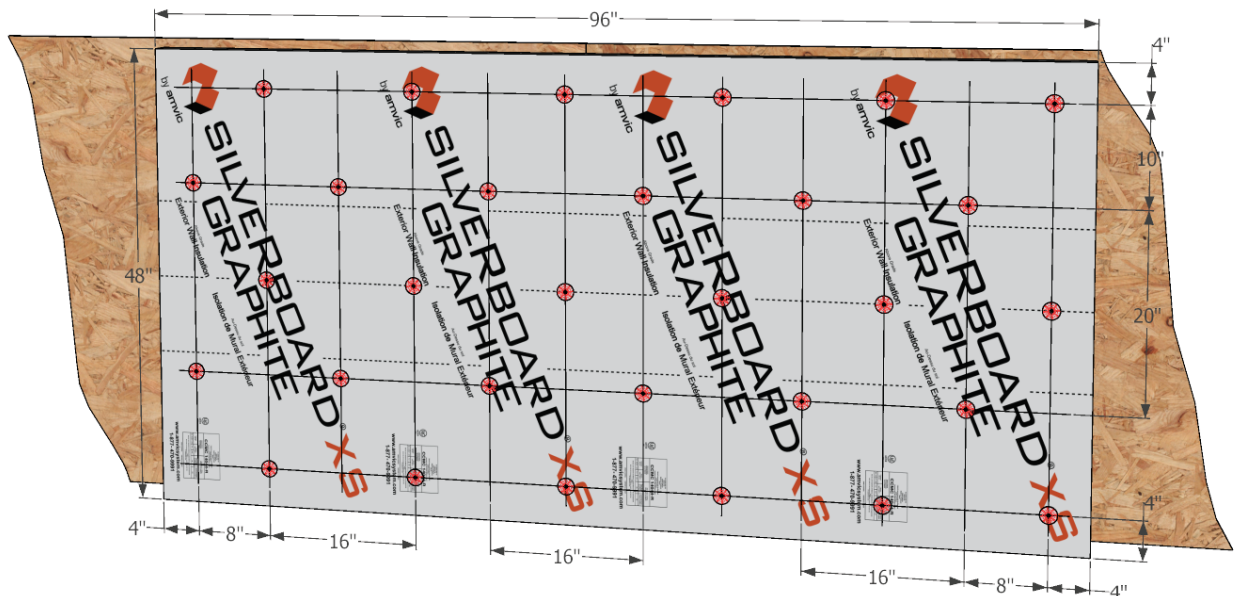

Horizontal nailing Pattern B - 30 assembled fasteners

## Typical Fastening Patterns - Wood Open Stud Assembly

- For open stud applications, the rigid insulation boards are fastened directly to the studs.
- Mechanical fasteners should be no more than 12-15" (305-381 mm) apart around the outside edge of the boards (brick ties and strapping also qualify as fasteners, do not duplicate).
- Use the printed guidelines on the boards to locate stud centers under the board.
- Do not over-torque fasteners. Fasteners are required at all outside edges, openings and intermediate framing members (if backing is available).
- Brick ties must fasten directly to structural members.

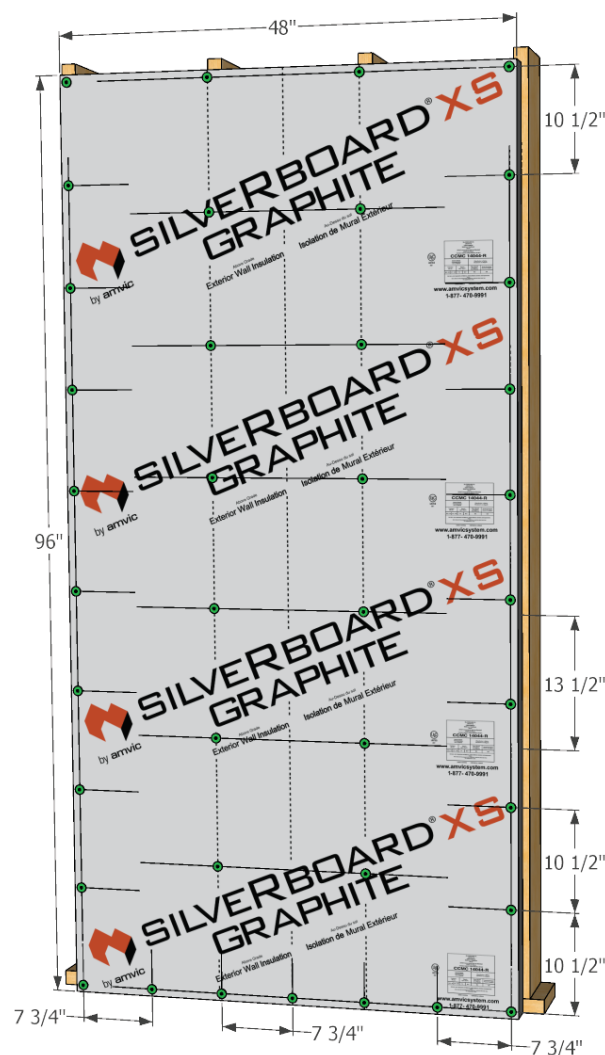

Vertical nailing pattern at 16" (406mm) o.c. studs (42 cap nails)

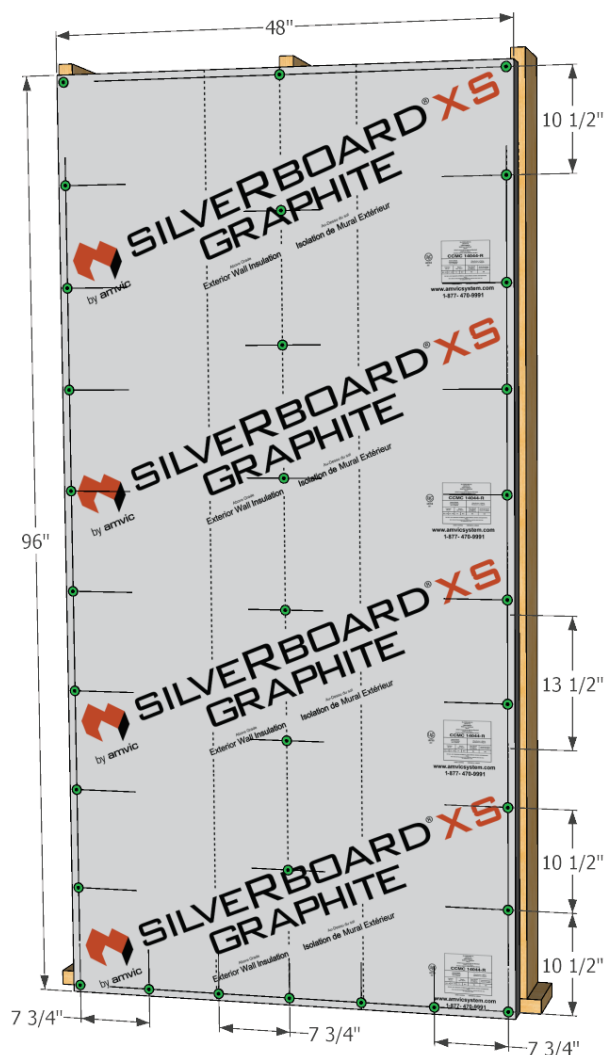

Vertical nailing pattern at 24" (610mm) o.c. studs (34 cap nails)

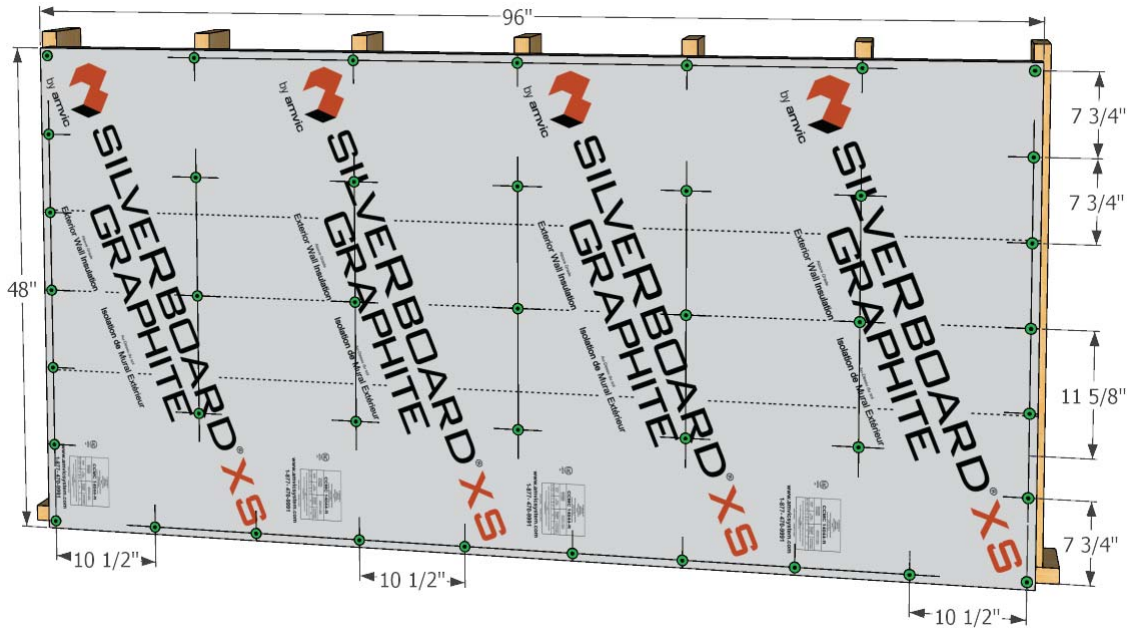

Horizontal nailing pattern at 16" (406mm) o.c. studs (42 cap nails)

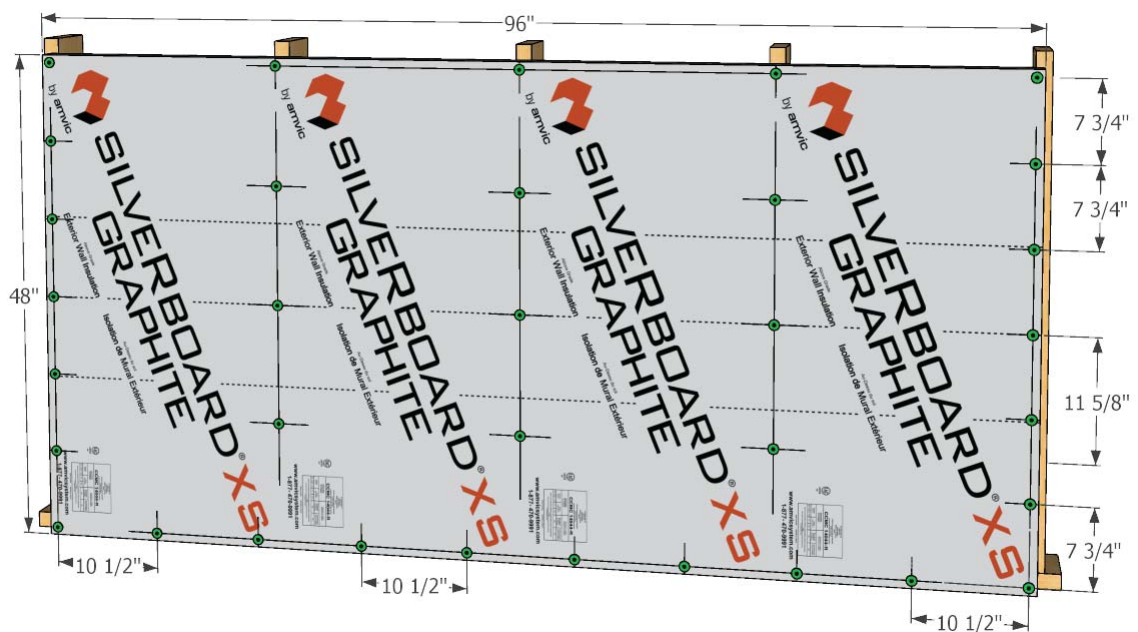

Horizontal nailing pattern at 24" (610mm) o.c. studs (34 cap nails)

### Typical Fastening Details - Wood Open Stud Assembly

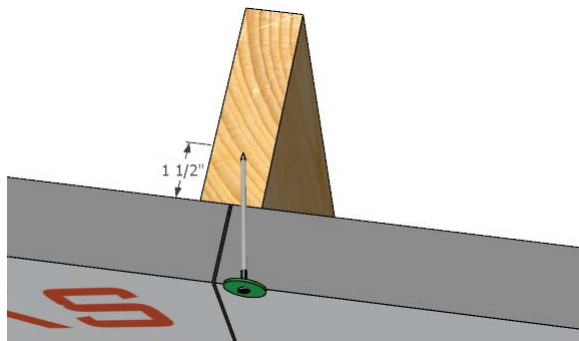
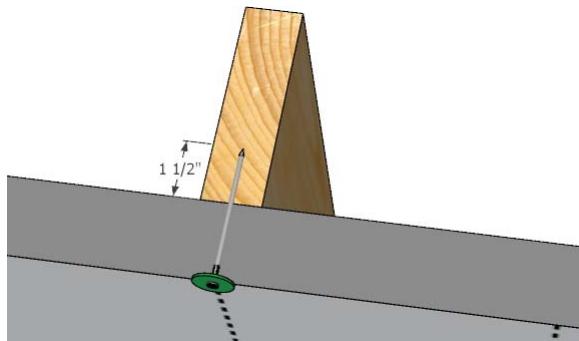

- At edge connections, angle the screws/nails to maintain distance from the edge while having sufficient penetration depth for the screw or nail.
- Allow for a minimum of 1.5" (38mm) of fastener length, over and above the total thickness of the insulation. E.g. for 1" (25mm) SilveRboard® Graphite XS + 1.5" (38mm) = 2.5" (63mm) nail/staple or screw.
- Minimum fastener diameter is 1" (25mm).
- For larger fasteners that might overlap at the edges, a staggered/alternating pattern with aforementioned spacing is needed.
- A distance of 3/4" (19mm) should be maintained from the edges in order to reduce potential tearing of the material.

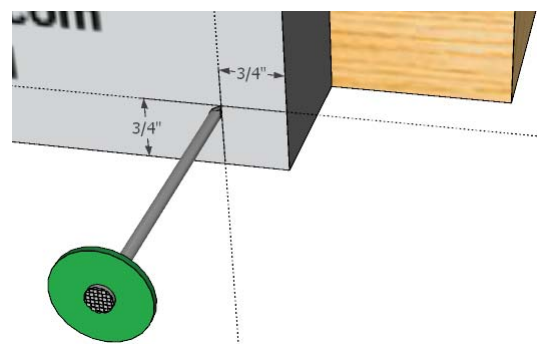
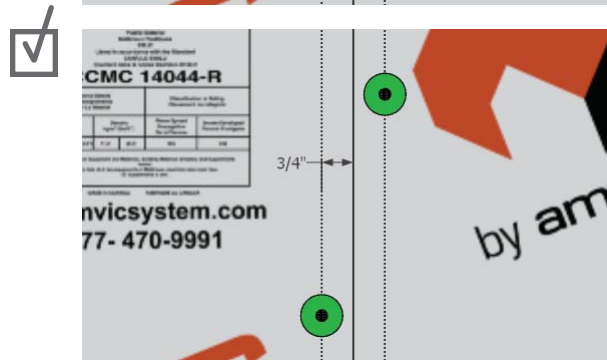
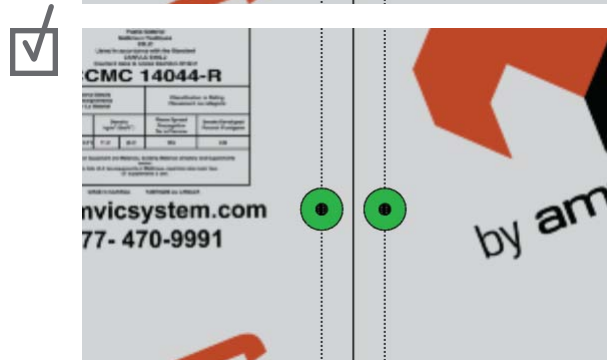
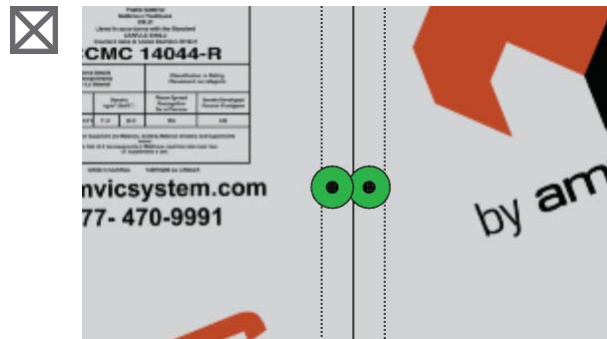
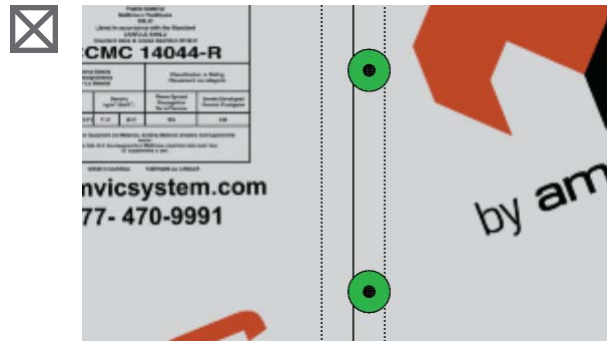

## Typical Fastening Patterns - Metal Open Stud Assembly

- For open stud applications, the rigid insulation boards are fastened directly to the studs.
- Mechanical fasteners should be no more than 12-15" (305-381mm) apart around the outside edge of the boards (brick ties and strapping also qualify as fasteners, do not duplicate).
- Use printed guidelines on the boards to locate stud centers under the board.
- Do not over-torque fasteners. Fasteners are required at all outside edges, openings and intermediate framing members (if backing is available).
- It is also recommended that the fasteners be at least 3/4" (19mm) in from edges or corners to prevent product tearing. Do not over-torque fasteners.

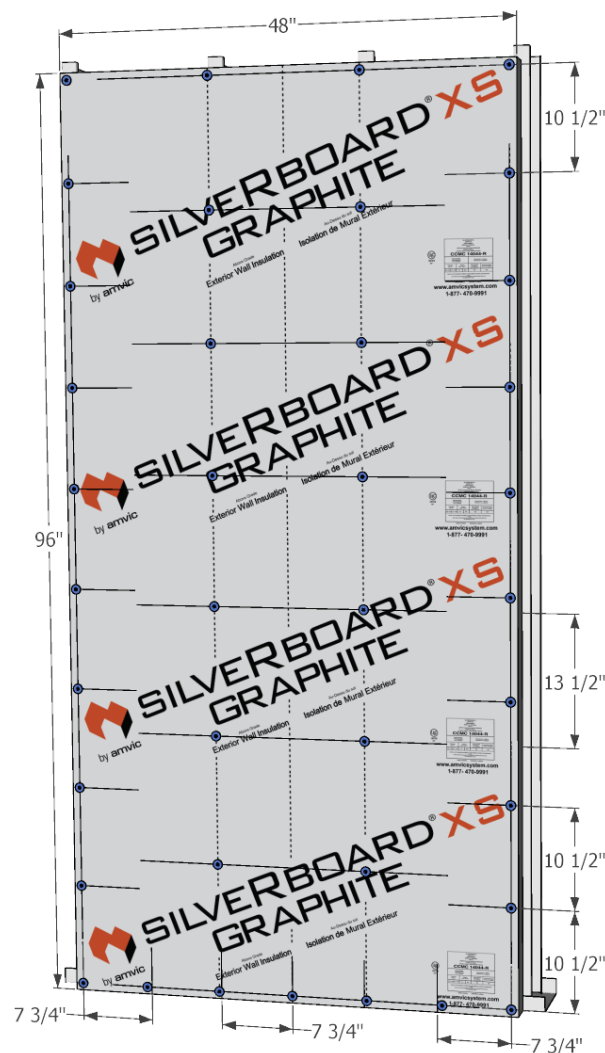

Vertical nailing pattern at 16" (406mm) o.c. studs (42 cap nails)

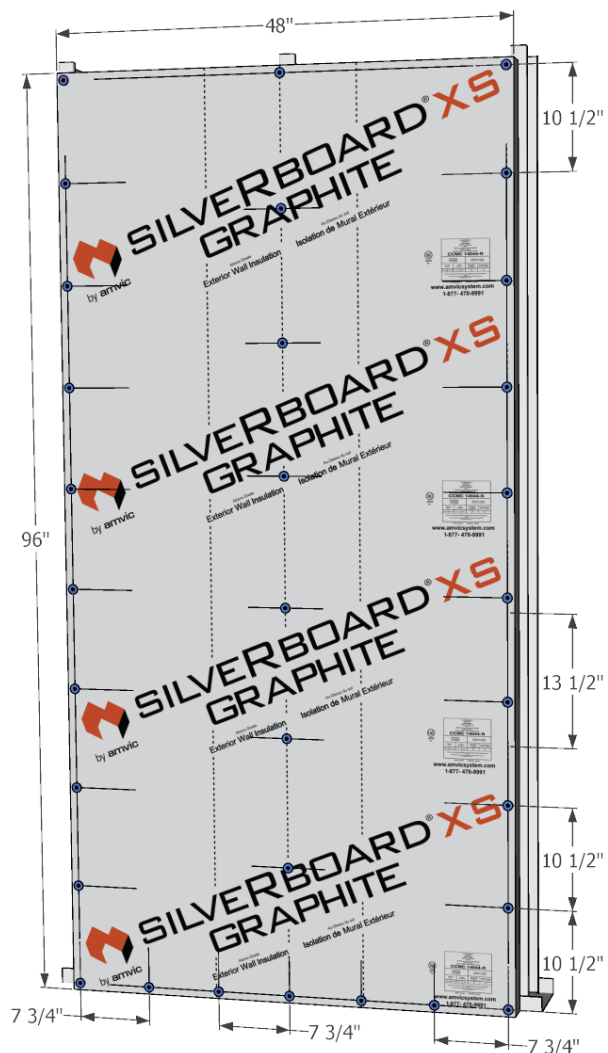

Vertical nailing pattern at 24" (610mm) o.c. studs (34 cap nails)



Taping pattern for vertical board orientation

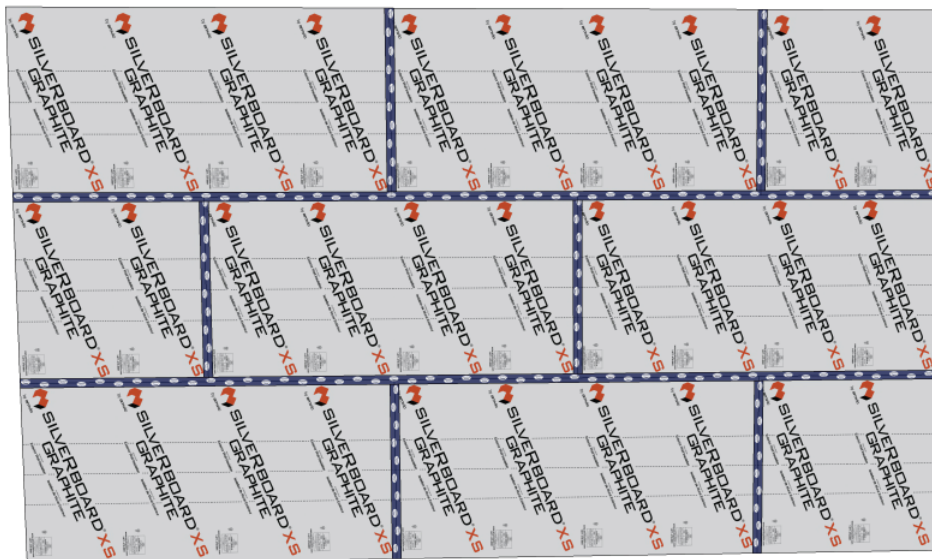

Taping pattern for horizontal board orientation

## Typical Joint Taping

- To maintain continuity of the weather barrier, tape all joints with a 60mm (2 3/8") sheathing tape.
- Installed fasteners do not need to be taped in order to maintain WRB continuity.
- At the board edges, center tape over the joints to cover fasteners.
- For joints, use shingle lapping technique.
- Tape should be installed in 15-120°F (-9.4-48.9°C) outdoor temperature (see tape manufacturer specifications).

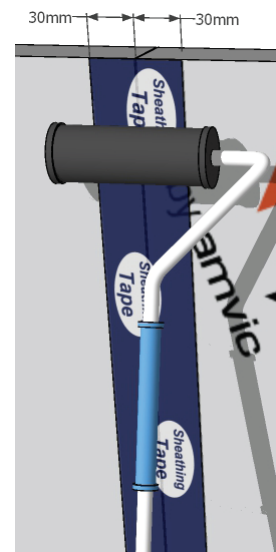

## Interior

For this type of application SilveRboard® Acoustic is recommended.

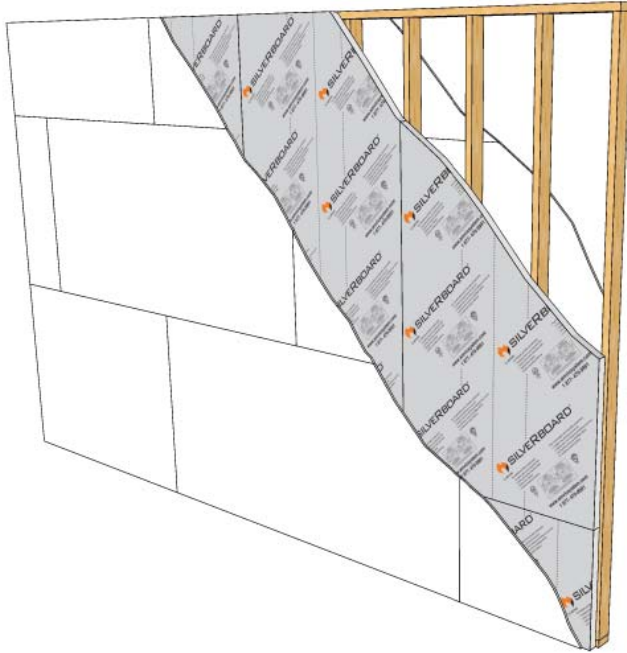

Typical interior acoustic partition

### Acoustic Partition Walls

- SilveRboard® Acoustic is a rigid flat sheet insulation board that offers sound control properties up to STC 19 & IIC 70 coupled with thermal resistance properties reaching a R5 (RSI 0.88).
- Best suited where dampening is either required or wanted such as demising walls, floors, ceiling, bathrooms, laundry rooms, theaters and quiet rooms.
- Typical construction consists of a standard wood frame wall with a single layer of 5/8" (16mm) gypsum board attached to one side.
- On the opposite side, SilveRboard® Acoustic and another layer of 5/8" (16mm) gypsum board are installed (staggered joint ts).
- The STC rating for the above wall assembly is 51-55 while a similar typical wall without SilveRboard® is rated at 32-36.

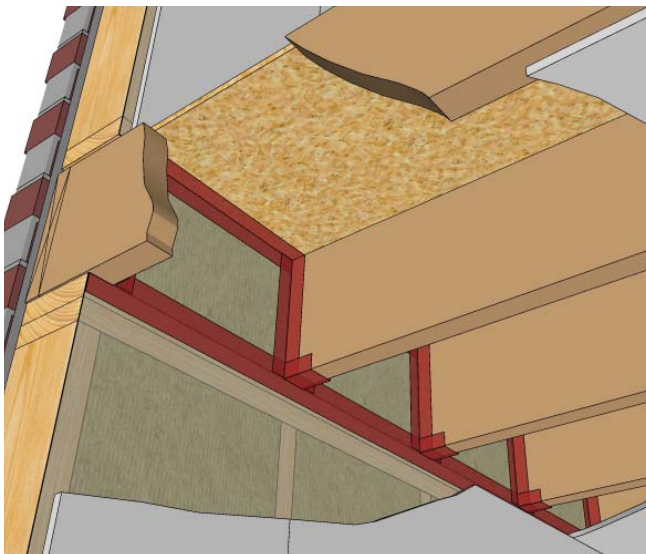

Rim joist at floor detail

### Maintaining Air Barrier Continuity

- Use sealant to seal rim boards to top plate, floor joists and underside of subfloor.
- Place batt insulation in the cavity between joists.
- Install 6 mil. polyethylene over the insulation. Overlap with membrane below. Seal and tape all edges using approved vapor barrier tape.

## Roof/Attic

For this type of application SilverBoard® is recommended.

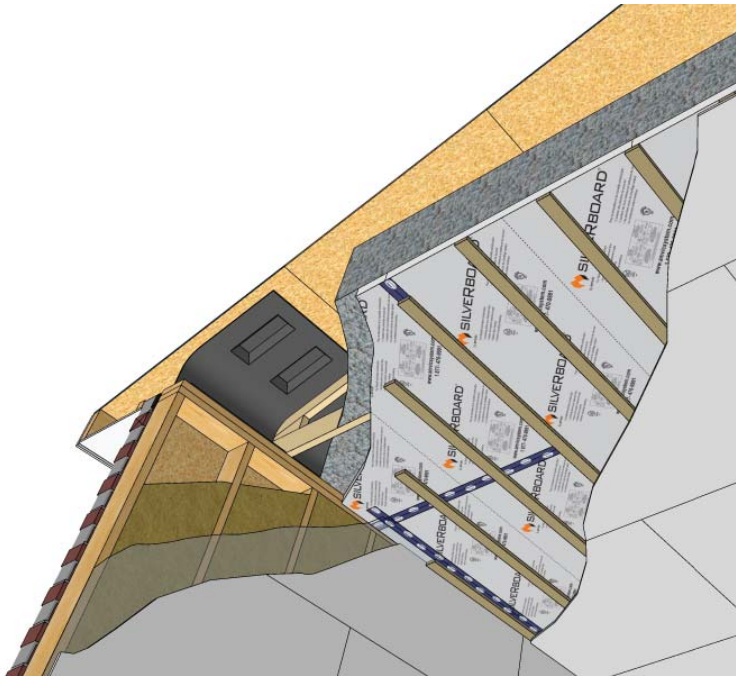

Application of SilverBoard on the underside of roof trusses

### Notes:

- *Gypsum board can be installed directly to the underside of SilverBoard® boards but would require the boards to be attached using cap nails/screws. Also, without an air cavity, benefits from radiant barrier are nulled.*
- *Provide sufficient air gap around heated penetrations (e.g. recessed lights, heating flues).*
- *Allow electrical rough-ins to accommodate for extra thickness insulation and furring strip thickness.*

### Standard Ceiling

- Provide wind baffles (insulation stops) along the perimeter of the wall to maintain 2" (51mm) air gap to promote air flow for proper attic ventilation.
- When using SilverBoard® with a vented attic, the boards are installed horizontally to the underside of roof trusses.
- Overlap wall vapor retarder 4" (102mm) onto the face of the SilverBoard®. Tape and seal all joints with approved vapor barrier tape.
- Install wood furring (16 or 24" (406 or 610 mm) o.c.), securing them directly into the trusses. Allow for a minimum of 1" (25mm) of fastener length, over and above the total thickness of the insulation board.
- Secure gypsum board to the wood furring.
- Once the ceiling assembly is installed, place insulation (loose fill or batt) on top of the boards to the required thickness.



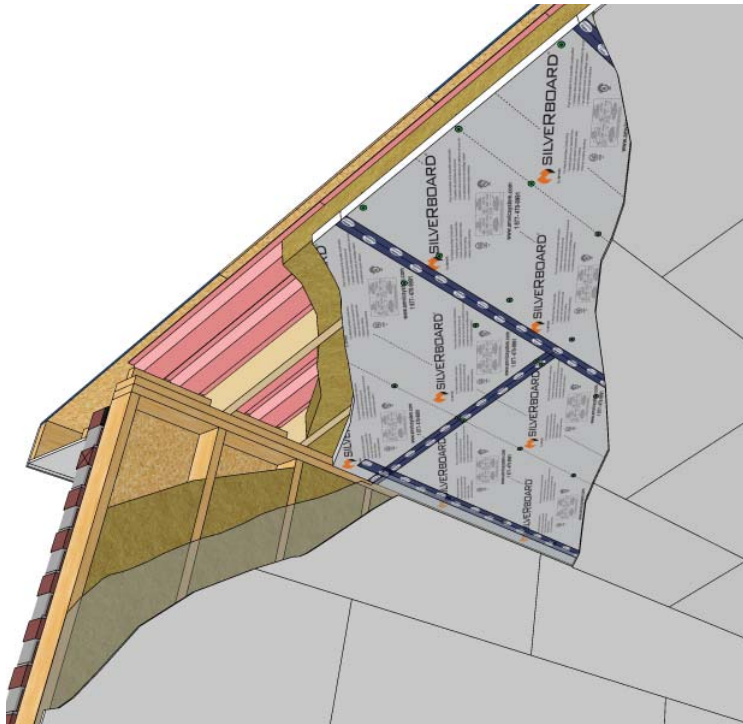

Application of SilverBoard in a cathedral ceiling

**Notes:**

- *Furring strips can be added between the SilverBoard® and the gypsum boards.*

## Cathedral Ceiling

- When using SilverBoard® in a cathedral ceiling configuration, a minimum of 2" (51mm) air gap is needed for ventilation.
- Install a continuous wind baffle to the underside of the roof substrate.
- Place batt insulation of appropriate thickness to fill the cavity between the rafters (accommodate thickness of wind baffle).
- Use cap nails/screws to secure SilverBoard® boards to the underside of rafters. Allow for a minimum of 1" (25mm) of fastener length, over and above the total thickness of the insulation board.
- A 3x7 (21 assembled fasteners) nailing pattern is recommended.
- Overlap wall vapor barrier 4" (102mm) onto the face of the SilverBoard®. Tape and seal all joints with approved vapor barrier tape.
- Install gypsum board directly to the underside of SilverBoard® (stagger joints) using longer gypsum screws to ensure proper fastening to the rafters.

## Fenestrations

### Flanged Window

The following steps illustrate a typical installation for flanged window with siding. Variations to these steps exist and could be fully acceptable, refer to window manufacturer or window installation standards (CSA 440A) for more information.

- Once the rough opening is cut to size, make sure it is level and plumb. Check that opening is square by measuring the diagonals.
- A wood back-dam (not shown) or a sloped sill plate should be used to facilitate water drainage.

1. Prime the sill area and allow to dry.

2. Use a self adhering flashing membrane to field fabricate a sill pan.

- Create end dam terminations by extending the self adhering flashing membrane up the vertical surface of the jambs a minimum of 6" (152mm).
- Finish the self adhering flashing membrane a minimum of 2" (51mm) into the cavity opening.
- Flashing membrane should extend a minimum of 4" (102mm) onto the face of the wall below the opening.

3. Install self adhering flashing membrane patches/gussets at lower corners.

- Triangular patch rough dimensions are 2x3" (51x76mm).
- Bow tie patch rough dimensions are 3x3" (76x76mm).

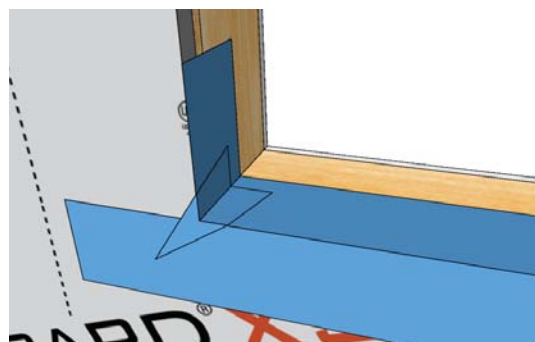
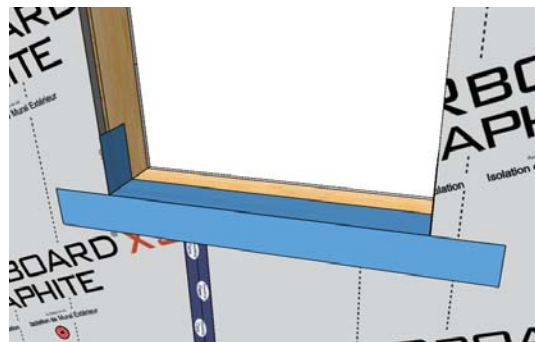
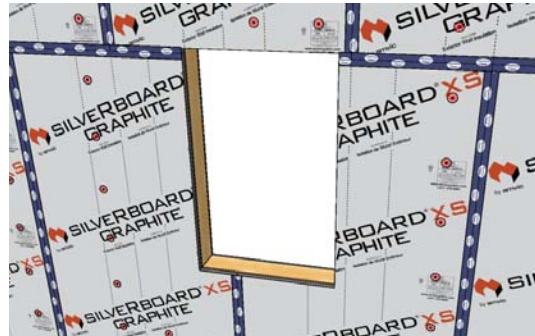

4. Apply sealant to secure wood blocking in place.
  - A gap of 1/4-5/8" (6-16mm) on all four sides is required.
  - Apply sealant around the perimeter of opening with notches/breaks under the sill to allow for drainage.
5. Install the window as per manufacturer's specifications.
  - Use galvanized roofing nails or truss screws.
  - Do not fasten 3-8" (76-203mm) from corners.
  - Fasten in center of every other slot (4-8" (102-203mm) spacing).
  - Do not dent the nailing fin.
  - Fastener heads should be flush.
6. Apply self adhering flashing membrane along the sides of the window.
  - Extend membrane a minimum of 2" (51mm) above the edge of the nail fin/flange.
  - Provide a minimum 2" (51mm) overlap over the sill flashing.
7. Apply self adhering flashing membrane along the top of the window overlapping the side strips by at least 2" (51mm).
  - A J-roller can be used to make sure membrane strips are properly adhered by removing gaps and bubbles.
  - Remove and replace parts that damaged as necessary.
8. Install preformed metal flashing at the head of the window.
  - Apply sealant between the window and the underside of the metal flashing.

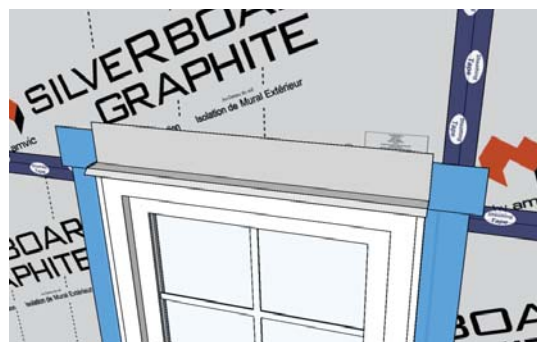
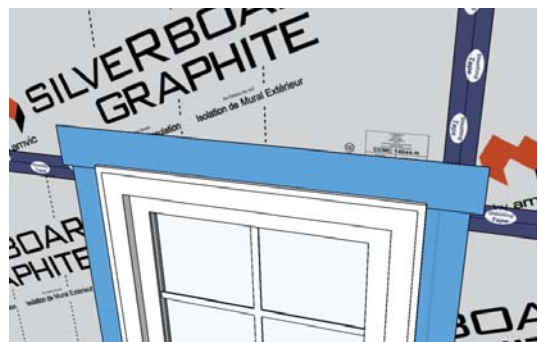
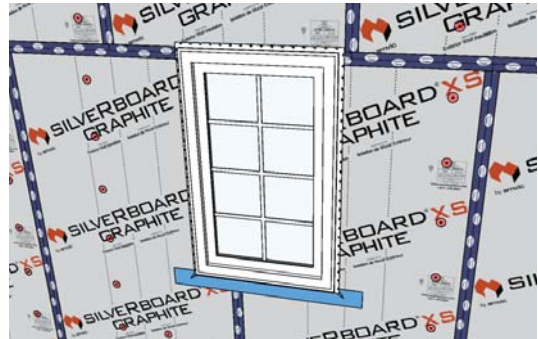
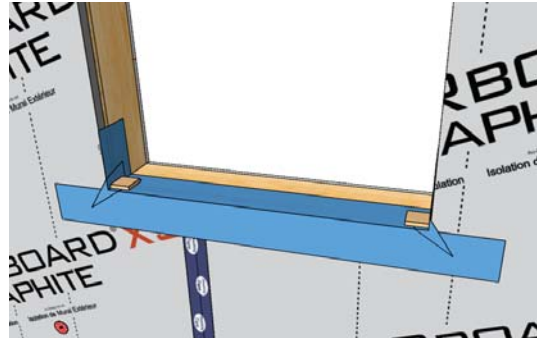

9. Seal the leading edge of the preformed metal flashing with self adhering flashing membrane.
  - Provide a minimum of 2" (51mm) overlap with the metal flashing and the substrate.

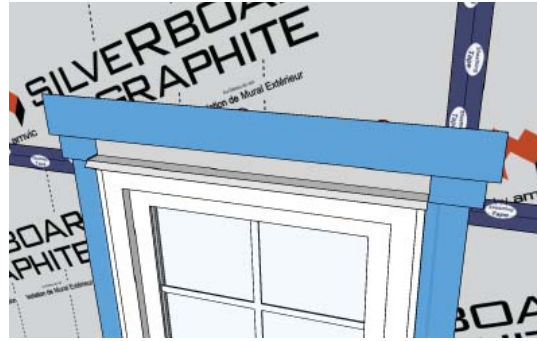

10. Install strapping for siding.

- Provide bugs screens at the top and bottom of the strapping.



11. Install window trim boards.

- Apply sealant around the perimeter of the window between the frame and the trim boards.
- Nail the trim boards together either during or after installation.



12. Install siding.



13. Apply low expansion spray foam insulation in cavity between the window and the rough opening.

- It is recommended to apply the foam between 40-100°F (4.4-37.8°C) for best results.

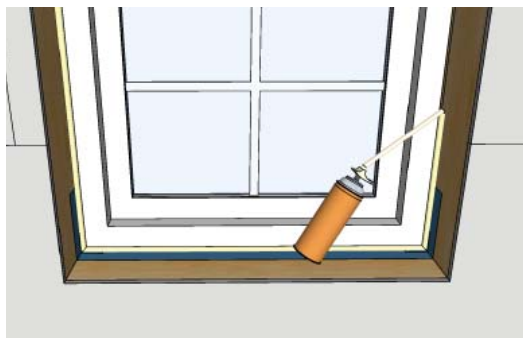

14. Let the spray foam fully cure and trim it using a sharp knife to be flush with the window frame.

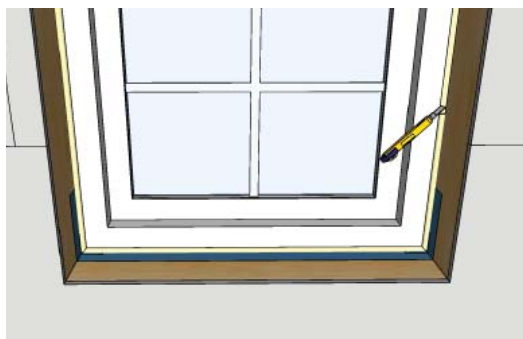

15. Install wood blocking/shims around the perimeter to the rough opening.

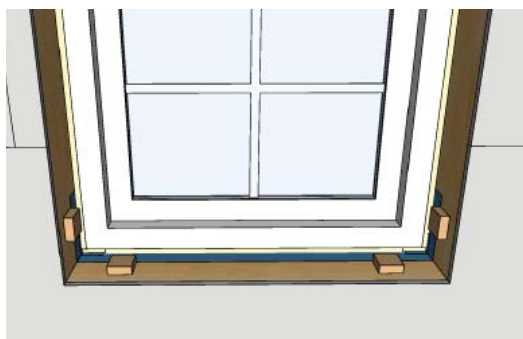

16. Install jamb extensions, securing them through the wood blocking to the rough opening.



17. Install window casing/trim.



## Non-Flanged Window

The following steps illustrate a typical installation for non-flanged window with siding. Variations to these steps exist and could be fully acceptable, refer to window manufacturer or window installation standards (CSA 440A) for more information.

- Once the rough opening is cut to size, make sure it is level and plumb. Check that opening is square by measuring the diagonals.
- A wood back-dam (not shown) or a sloped sill plate should be used to facilitate water drainage.

1. Prime the sill area and allow to dry.
2. Use a self adhering flashing membrane to field fabricate a sill pan.
  - Create end dam terminations by extending the self adhering flashing membrane up the vertical surface of the jambs a minimum of 6" (152mm).
  - Finish the self adhering flashing membrane a minimum of 2" (51mm) into the cavity opening.
  - Flashing membrane should extend a minimum of 4" (102mm) onto the face of the wall below the opening.
3. Install self adhering flashing membrane patches/gussets at lower corners.
  - Triangular patch rough dimensions are 2x3" (51x76mm).
  - Bow tie patch rough dimensions are 3x3" (76x76mm).
4. Apply self adhering flashing membrane along the sides of the opening.
  - Extend membrane a minimum of 4" (102mm) on the face of the insulation and window opening jambs.
  - Provide a minimum 2" (51mm) overlap over the sill flashing.

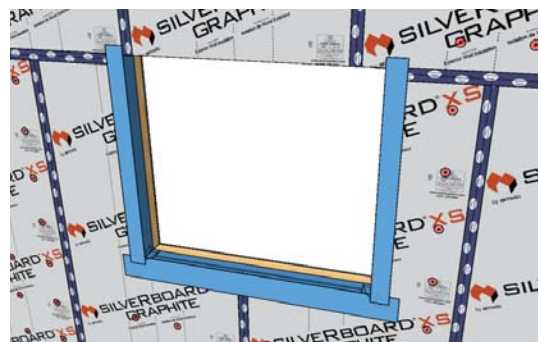
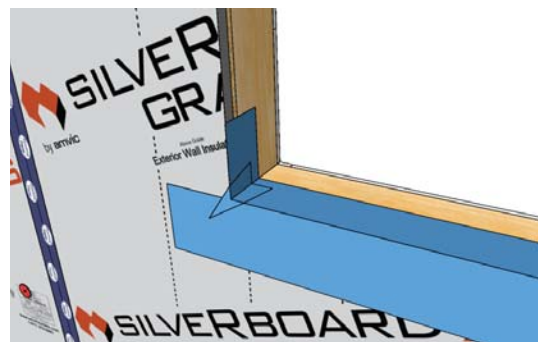
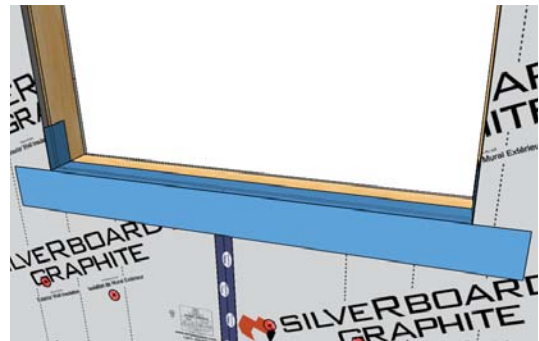
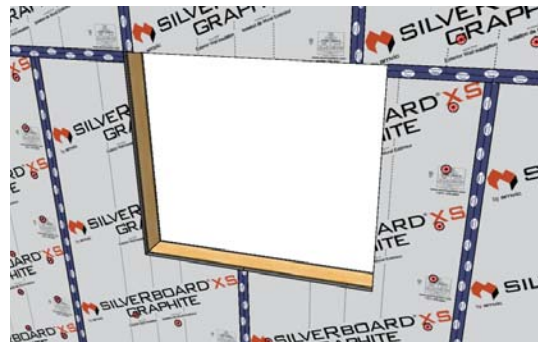

5. Apply self adhering flashing membrane along the top of the window opening.

- Extend membrane a minimum of 4" (102mm) on the face of the insulation and window opening jambs.
- Provide a minimum 2" (51mm) overlap over the jamb flashing.

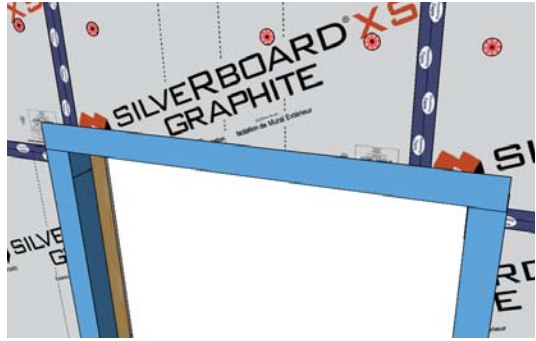

6. Install wood blocking on top of membrane, use sealant to hold it in place until installation of the window.

- A gap of 1/4-5/8" (6-16mm) on all four sides is required.

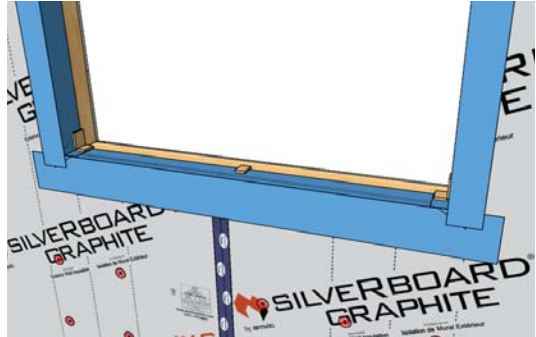

7. Install the window as per manufacturer's specifications.

- Use wood shims/blocks in the gap to prevent warping of window frame when attaching to the substrate.
- Use appropriate length truss head screws.

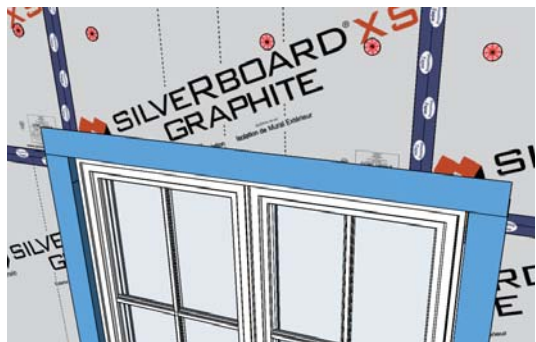

8. Install backer rod and sealant around the exterior perimeter of the window frame.

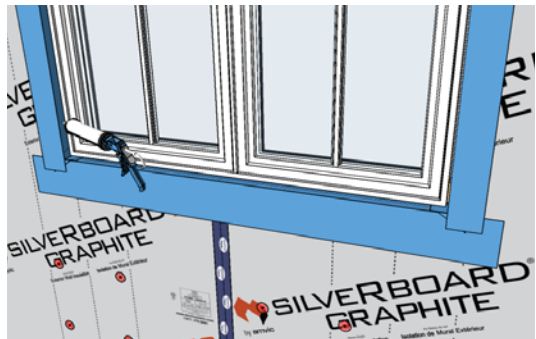

9. Install preformed metal flashing at the head of the window.



10. Apply self adhering flashing membrane to seal the leading of the metal flashing.

- Provide a minimum of 2" (51mm) overlap with the metal flashing and the substrate.

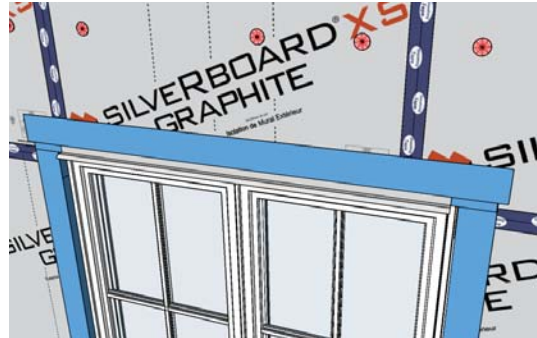

11. Install strapping for siding.

- Provide bugs screens at the top and bottom of the strapping.



12. Install window trim boards and returns.

- Nail the trim boards together either during or after installation.



13. Install preformed metal flashing at window sill.

- Apply sealant around the perimeter of the window between the frame, the trim boards and flashing.



14. Install exterior siding.





15. Apply low expansion spray foam insulation in cavity between the window and the rough opening.

- It is recommended to apply the foam between 40-100°F (4.4-37.8°C) for best results (check with manufacturer).

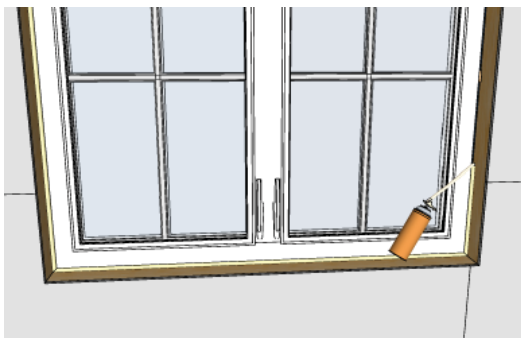

16. Let the spray foam fully cure and trim it using a sharp knife to be flush with the window frame.

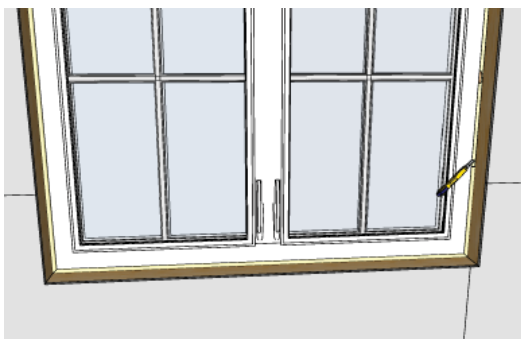

17. Install wood blocking/shims around the perimeter to the rough opening.

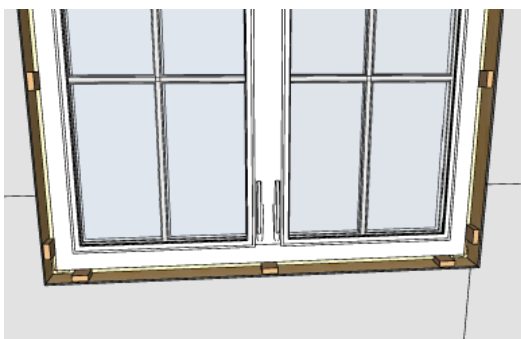

18. Install jamb extensions, securing them through the wood blocking to the rough opening.

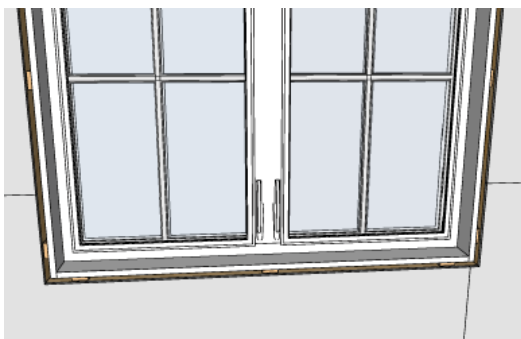

19. Install window casing/trim.



## Swing Door

The following steps illustrate a typical installation for an exterior swing door with siding. Variations to these steps exist and could be fully acceptable, refer to window & door manufacturer or door installation standards (CSA) for more information.

1. Once the rough opening is cut to size, make sure it is level and plumb. Check that opening is square by measuring the diagonals.



2. Apply self adhering flashing membrane along the bottom of the opening.
  - Extend membrane a minimum of 4" (102mm) on the face of the insulation.

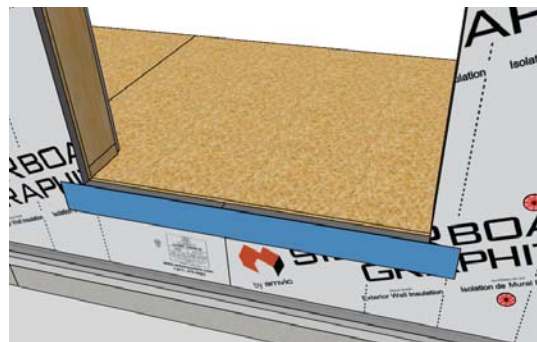

3. Install and seal pan flashing along the bottom of the opening.

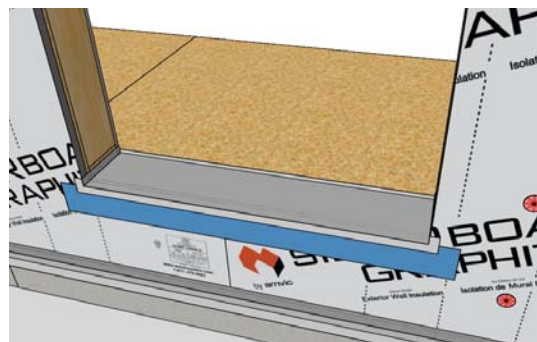

4. Apply self adhering flashing membrane along the sides of the opening.
  - Extend membrane a minimum of 4" (102mm) on the face of the insulation and door opening jambs.
  - Provide a minimum of 1" (51mm) overlap over the pan flashing.



5. Apply self adhering flashing membrane along the top of the window opening.

- Extend membrane a minimum of 4" (102mm) on the face of the insulation and window opening jambs.
- Provide a minimum 2" (51mm) overlap over the jamb flashing.

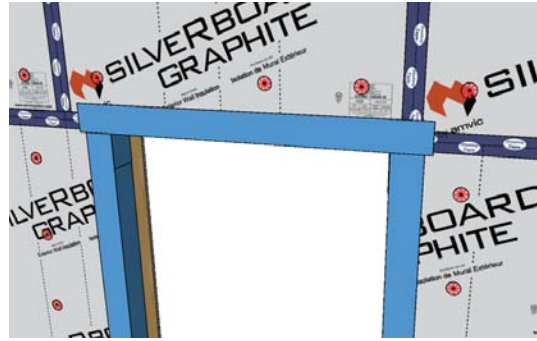

6. Install pressure treated subsill.

- Apply sealant to secure subsill to pan flashing.

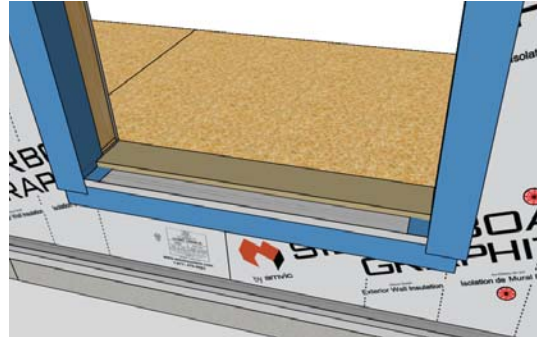

7. Install pre-finished sill extension.

- Provide a minimum slope of 2% for drainage.

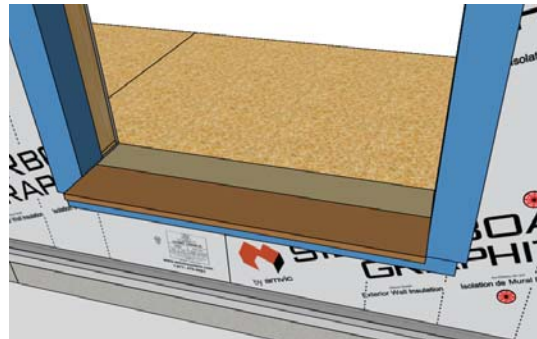

8. Install the door as per manufacturer's specifications.

- Apply two sets of sealant beads to the threshold.



9. Install sealant and backer rod around the exterior perimeter of the door frame.



10. Install preformed metal flashing at the head of the window.

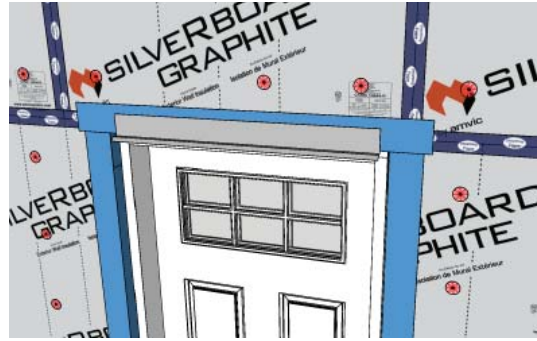

11. Apply self adhering flashing membrane to seal the leading of the metal flashing.

- Provide a minimum of 2" (51mm) overlap with the metal flashing and the substrate.



12. Install strapping for siding.

- Provide bug screens at the top and bottom of the strapping.



13. Install door trim boards and returns.

- Nail the trim boards together either during or after installation.
- Apply sealant between door frame, trim boards and sill extension.



14. Install exterior siding.



15. Apply low expansion spray foam insulation in cavity between the window and the rough opening.

- It is recommended to apply the foam between 40-100°F (4.4-37.8°C) for best results, see manufacturer requirements.

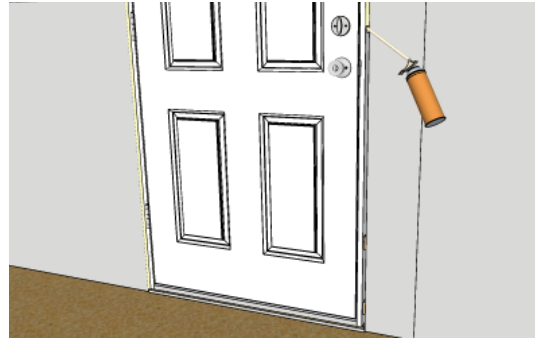

16. Let the spray foam fully cure and trim it using a sharp knife to be flush with the window frame.

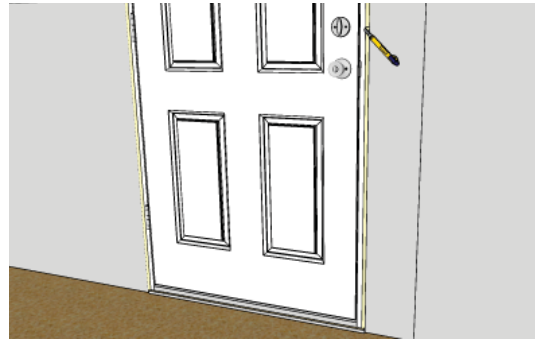

17. Install door casing/trim.



## Penetrations

1. Cut a rough opening as close to the size and shape to that of the duct/pipe (boards can be cut using a utility knife or a fine tooth hand saw). Install the U-shaped self adhered membrane in the lower half of the opening.

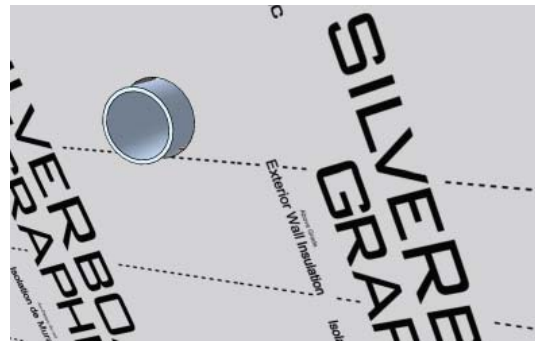

2. Install the duct/pipe into the opening. Secure the duct/pipe in place using blocks/support on the interior side of the wall.

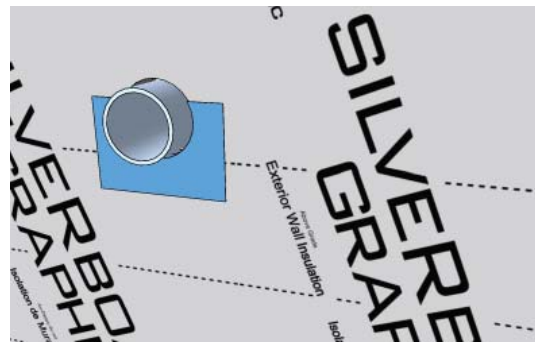

3. Install the second U-shaped self adhered membrane in the upper part of the opening with 2" (51mm) overlap with the lower portion.

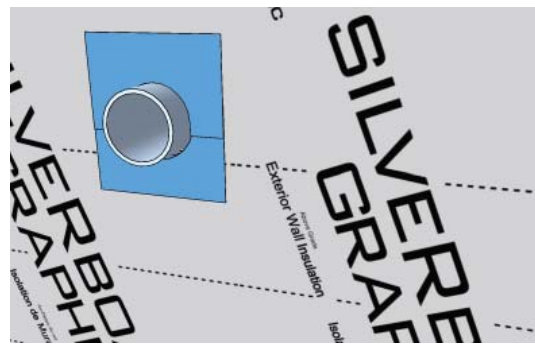

4. Use sheathing tape to seal the leading edge of the self adhered membrane.

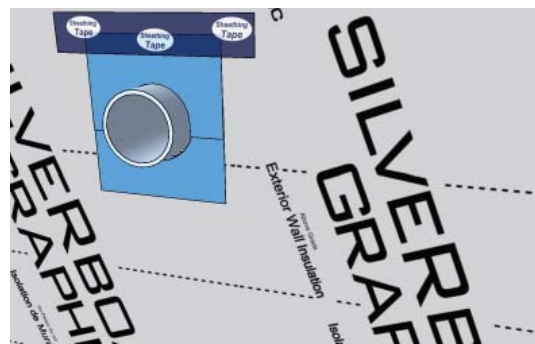

5. Apply sealant at the junction of the self adhered membrane and the duct/pipe to eliminate ingress of moisture and air.

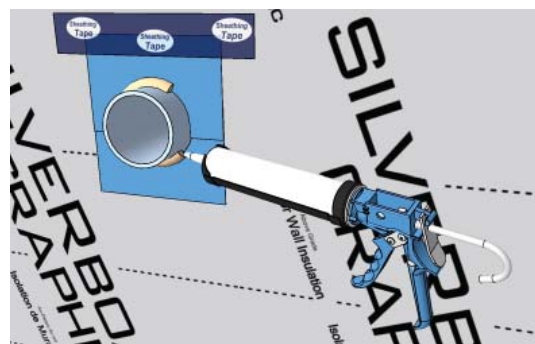

## Attic Access Hatch

1. Install wood blocking between the joists.
  - Cut the SilveRboard® to be flush with the opening.
  - Tape using sheathing tape over all the seams to ensure vapor barrier continuity.
2. Install furring strips for the entire ceiling area as well as around the opening.
  - Install OSB along the sides to the height of the roof insulation in order to prevent it from interfering with hatch opening/closing operation.
  - Apply sealant along the perimeter of the rough opening and the OSB sides.
3. Install wood stops to for the hatch to rest on.
  - Attach gypsum board to the furring strips through the ceiling area.
4. Add a narrow border of adhesive-backed foam weather stripping around the perimeter on top of the stops to maintain air barrier continuity.
  - Install casing/trim pieces around the perimeter.
  - Make sure sash locks are in place to engage cover to compress weather stripping.
5. Place the removable hatch cover before adding attic insulation.
  - Hatch cover consists of a piece of plywood (painted on underside) attached to insulation boards cut, glued to the required thickness to achieve similar R-value as the rest of the roof assembly.

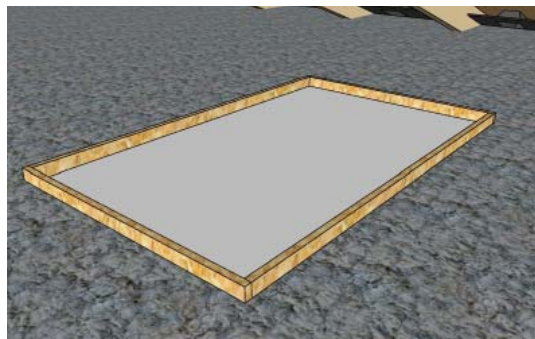
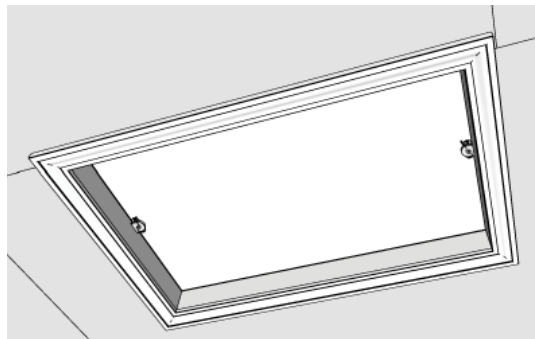
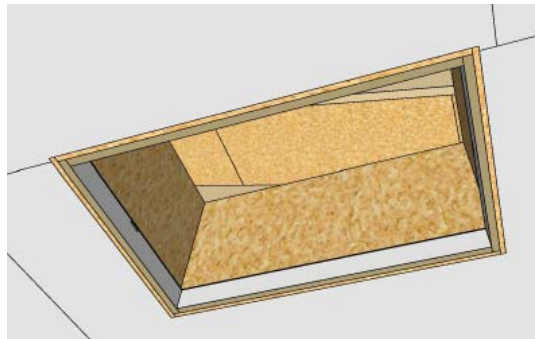
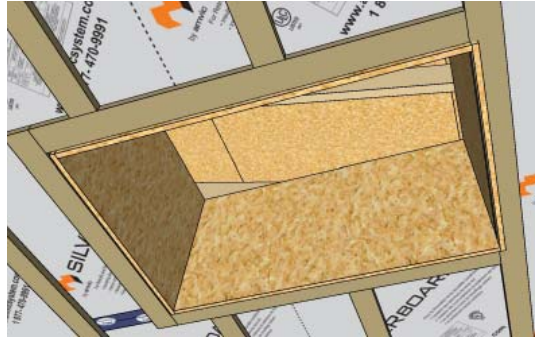
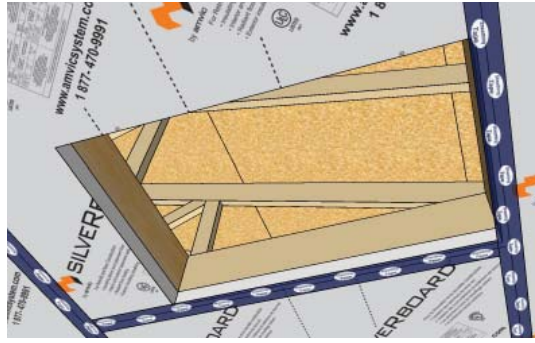

## Repairs

When SilverBoard is installed without the use of a weather barrier behind it. It is important to seal various holes and gaps in order to maintain the continuity of the water shedding surface acting as the second plane of protection in a cavity wall. For damages that do not compromise the integrity of the board, the following methodologies can be used for repair.

1. For cracks and tears in the foil use sheathing tape to patch and reinforce the affected area.



2. Broken pieces can be reattached to the board using sheathing tape from both sides to secure it in place.

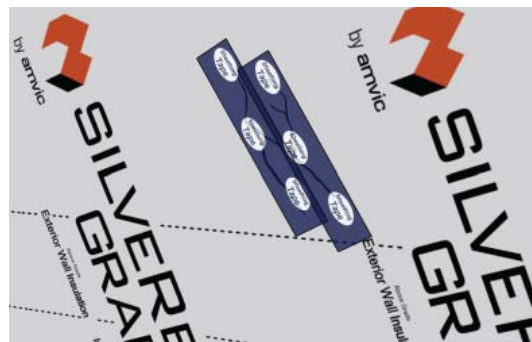

3. Small holes should be filled with sealant.

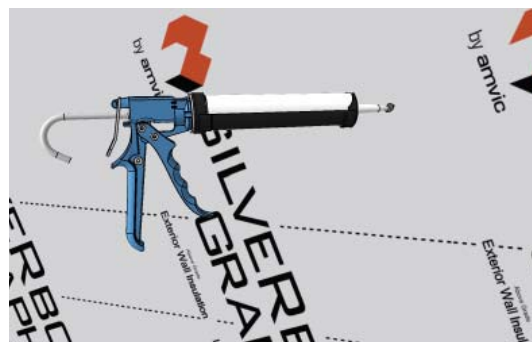

4. Medium sized holes can be sealed with compatible spray foam insulation. Once the foam is cured, tape over the area with sheathing tape.





1. For larger holes it may be necessary to replace the entire board. If that is not the case, the following steps outline the repair procedure.

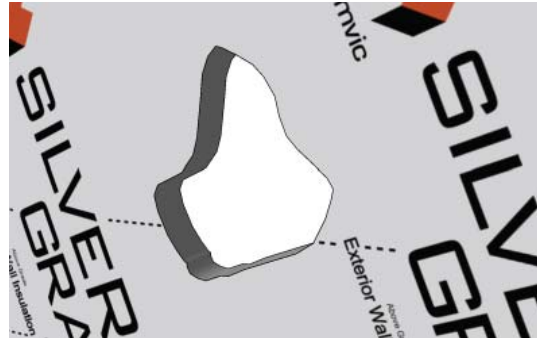

2. Cut out a rectangular replacement piece from a scrap board which is larger than the hole.

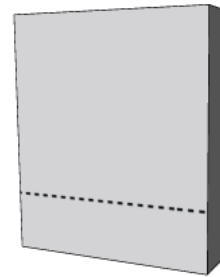

3. Use the replacement piece to outline and cut out the damaged area.

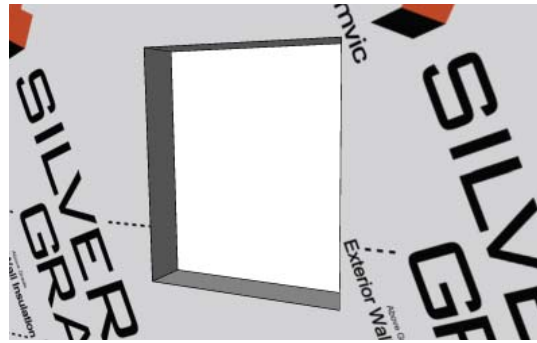

4. Place the replacement piece from the outside. Use spray foam insulation to seal gaps as needed.

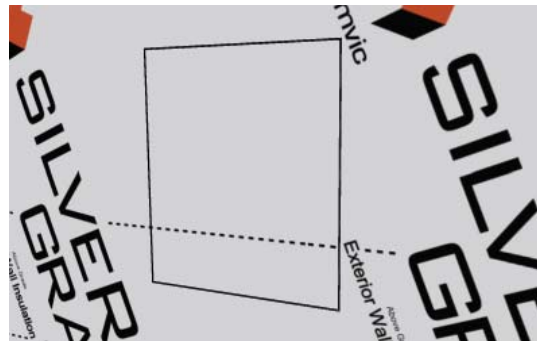

5. Tape over the joints with sheathing tape for both interior and exterior faces.

- Alternative Method

If edges are beveled to the interior, use spray foam insulation around the perimeter. Trim flush excess foam after it is cured and dry.

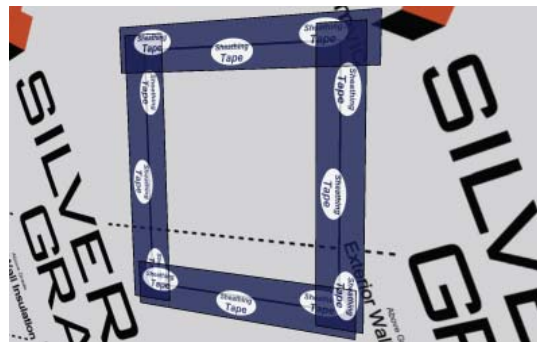

## SilveRboard®

Standard	Description	SB-12	SB-21	SB-35	SB-44	SB-35 XS
ASTM D1622	Density lb/ft <sup>3</sup> (Kg/m <sup>3</sup> )	1.0 (16)	1.5 (24)	2.0 (32)	2.5 (40)	2.0 (32)
ASTM C518	R-value/1-inch @ 75°F (ft <sup>2</sup> ·°F·h/Btu) RSI/25mm @ 24°C (m <sup>2</sup> K/W)	4.1 (0.72)	4.3 (0.76)	5.0 (0.88)	5.0 (0.88)	5.0 (0.88)
ASTM STP1320	R-value/1-inch @ 0°F (ft <sup>2</sup> ·°F·h/Btu) RSI/25mm @ -18°C (m <sup>2</sup> K/W)	5.2 (0.91)	5.5 (0.96)	6.0 (1.05)	6.0 (1.05)	6.0 (1.05)
ASTM D1621	Compressive strength at 10% strain psi (kPa)	12.8 (88.2)	21.5 (147.9)	35.6 (245.5)	44.4 (306.1)	35.6 (245.5)
ASTM C203	Flexural strength psi (kPa)	40 (277)	60 (414)	84 (579)	106 (730)	84 (579)
ASTM D2842	Water absorption % by volume	0.850	0.680	0.430	0.075	0.043
ASTM E96	Water vapor permeance US perm (ng/ Pa*s*m <sup>2</sup> )	0.210 (12.00)	0.150 (8.60)	0.075 (4.27)	0.028 (1.60)	3.480 (217.00)
ASTM D2126	Dimensional stability linear change (%)	-0.147	-0.108	-0.100	-0.100	-0.100
ASTM D2863	Limiting oxygen index (%)	>24	>24	>24	>24	>24
ASTM E2178-11	Standard test method for air permeance of building materials @ 75 pa (L/s*m <sup>2</sup> )					0.01

## SilveRboard® Graphite XS

Standard	Description	Test Results
ASTM C518	R-value/1-inch @ 75°F (ft <sup>2</sup> ·°F·h/Btu) RSI/25mm @ 24°C (m <sup>2</sup> K/W)	4.5 (0.78)
ASTM C518	R-value/1-inch @ 0°F (ft <sup>2</sup> ·°F·h/Btu) RSI/25mm @ -18°C (m <sup>2</sup> K/W)	5.4 (1.00)
ASTM E96	Water vapor permeance US perm (ng/Pa*s*m <sup>2</sup> )	0.77 (44)
ASTM E96 (Perforated)	Water vapor permeance US perm (ng/Pa*s*m <sup>2</sup> )	2.74 (157)
ASTM D2126	Dimensional stability linear change (%)	Length - 0.18 Width - 0.15
ASTM C203	Flexural strength psi (kPa)	26 (180)
ASTM C272	Water absorption % by volume	0.18
ASTM D2863	Limiting oxygen index (%)	<24
CAN/ULC S102.2	Flame spread 155	Smoke developed 340

## SilveRboard® - Non-Perforated

SKU #	Compressive Strength	R-value	Thickness	Dimensions	Packaging
SB21S0500S	21.5 PSI (148 kPa)	R2.1 (0.37 RSI)	1/2" (13mm)	4' x 8' (1.2m x 2.4m)	60 sheets/ bundle
SB21S0750S	21.5 PSI (148 kPa)	R3 (0.53 RSI)	3/4" (19mm)	4' x 8' (1.2m x 2.4m)	40 sheets/ bundle
SB21S1100S	21.5 PSI (148 kPa)	R4.7 (0.83 RSI)	1.1" (28mm)	4' x 8' (1.2m x 2.4m)	27 sheets/ bundle
SB21S1660S	21.5 PSI (148 kPa)	R7.1 (1.25 RSI)	1.66" (42mm)	4' x 8' (1.2m x 2.4m)	18 sheets/ bundle
SB21S2200S	21.5 PSI (148 kPa)	R9.4 (1.66 RSI)	2.2" (56mm)	4' x 8' (1.2m x 2.4m)	13 sheets/ bundle

\*Metric values serve as nominal conversions. Tables should be used only as a reference. For the most up to date product availability and pricing contact your local sales representatives.

## SilveRboard® - Non-Perforated

SKU #	Compressive Strength	R-value	Thickness	Dimensions	Packaging
SB35S0500S	35.6 PSI (245.5 kPa)	R2.5 (0.44 RSI)	1/2" (13mm)	4' x 8' (1.2m x 2.4m)	60 sheets/ bundle
SB35S0750S	35.6 PSI (245.5 kPa)	R3.75 (0.66 RSI)	3/4" (19mm)	4' x 8' (1.2m x 2.4m)	40 sheets/ bundle
SB35S1000S	35.6 PSI (245.5 kPa)	R5 (0.88 RSI)	1" (25mm)	4' x 8' (1.2m x 2.4m)	30 sheets/ bundle
SB35S1002S	35.6 PSI (245.5 kPa)	R5 (0.88 RSI)	1" (25mm)	2' x 8' (0.6m x 2.4m)	30 sheets/ bundle
SB35S1009S	35.6 PSI (245.5 kPa)	R5 (0.88 RSI)	1" (25mm)	4' x 9' (1.2m x 2.7m)	30 sheets/ bundle
SB35S1500S	35.6 PSI (245.5 kPa)	R7.5 (1.32 RSI)	1.5" (38mm)	4' x 8' (1.2m x 2.4m)	20 sheets/ bundle
SB35S1502S	35.6 PSI (245.5 kPa)	R7.5 (1.32 RSI)	1.5" (38mm)	2' x 8' (0.6m x 2.4m)	20 sheets/ bundle
SB35S2000S	35.6 PSI (245.5 kPa)	R10 (1.76 RSI)	2" (51mm)	4' x 8' (1.2m x 2.4m)	15 sheets/ bundle
SB35S2002S	35.6 PSI (245.5 kPa)	R10 (1.76 RSI)	2" (51mm)	2' x 8' (0.6m x 2.4m)	15 sheets/ bundle
SB35S2009S	35.6 PSI (245.5 kPa)	R10 (1.76 RSI)	2" (51mm)	4' x 9' (1.2m x 2.7m)	15 sheets/ bundle
SB35S3000S	35.6 PSI (245.5 kPa)	R15 (2.64 RSI)	3" (76mm)	4' x 8' (1.2m x 2.4m)	10 sheets/ bundle
SB35S3002S	35.6 PSI (245.5 kPa)	R15 (2.64 RSI)	3" (76mm)	2' x 8' (0.6m x 2.4m)	10 sheets/ bundle
SB35S3500S	35.6 PSI (245.5 kPa)	R17.5 (3.08 RSI)	3.5" (89mm)	2' x 8' (0.6m x 2.4m)	8 sheets/ bundle

\*Metric values serve as nominal conversions. Tables should be used only as a reference. For the most up to date product availability and pricing contact your local sales representatives.

## SilveRboard® - Non-Perforated

SKU #	Compressive Strength	R-value	Thickness	Dimensions	Packaging
SB44S0500S	44.4 PSI (306 kPa)	R2.5 (0.44 RSI)	1/2" (13mm)	4' x 8' (1.2m x 2.4m)	60 sheets/ bundle
SB44S0750S	44.4 PSI (306 kPa)	R3.75 (0.66 RSI)	3/4" (19mm)	4' x 8' (1.2m x 2.4m)	40 sheets/ bundle
SB44S1000S	44.4 PSI (306 kPa)	R5 (0.88 RSI)	1" (25mm)	4' x 8' (1.2m x 2.4m)	30 sheets/ bundle
SB44S1002S	44.4 PSI (306 kPa)	R5 (0.88 RSI)	1" (25mm)	2' x 8' (0.6m x 2.4m)	30 sheets/ bundle
SB44S2000S	44.4 PSI (306 kPa)	R10 (1.76 RSI)	2" (51mm)	4' x 8' (1.2m x 2.4m)	15 sheets/ bundle
SB44S2002S	44.4 PSI (306 kPa)	R10 (1.76 RSI)	2" (51mm)	2' x 8' (0.6m x 2.4m)	15 sheets/ bundle
SB44S2500S	44.4 PSI (306 kPa)	R12.5 (2.2 RSI)	2.5" (63.5mm)	4' x 8' (1.2m x 2.4m)	12 sheets/ bundle
SB44S3000S	44.4 PSI (306 kPa)	R15 (2.64 RSI)	3" (76mm)	4' x 8' (1.2m x 2.4m)	10 sheets/ bundle
SB44S3002S	44.4 PSI (306 kPa)	R15 (2.64 RSI)	3" (76mm)	2' x 8' (0.6m x 2.4m)	10 sheets/ bundle
SB44S4000S	44.4 PSI (306 kPa)	R20 (3.52 RSI)	4" (101mm)	4' x 8' (1.2m x 2.4m)	7 sheets/ bundle

SKU #	Compressive Strength	R-value	Thickness	Dimensions	Packaging
SB60S1002S	60.0 PSI (413.7 kPa)	R5 (0.88 RSI)	1" (25mm)	2' x 8' (0.6m x 2.4m)	60 sheets/ bundle
SB60S2000S	60.0 PSI (413.7 kPa)	R10 (1.76 RSI)	2" (51mm)	4' x 8' (1.2m x 2.4m)	15 sheets/ bundle
SB60S2002S	60.0 PSI (413.7 kPa)	R10 (1.76 RSI)	2" (51mm)	2' x 8' (0.6m x 2.4m)	30 sheets/ bundle

\*Metric values serve as nominal conversions. Tables should be used only as a reference. For the most up to date product availability and pricing contact your local sales representatives.

## SilveRboard® - Perforated

SKU #	Compressive Strength	R-value	Thickness	Dimensions	Packaging
SB12XS058P	12.1 PSI (83.4 kPa)	R2 (0.35 RSI)	1/2" (13mm)	4' x 8' (1.2m x 2.4m)	60 sheets/ bundle
SB12XS078P	12.1 PSI (83.4 kPa)	R3 (0.53 RSI)	3/4" (19mm)	4' x 8' (1.2m x 2.4m)	40 sheets/ bundle
SB12XS108P	12.1 PSI (83.4 kPa)	R4 (0.70 RSI)	1" (25mm)	4' x 8' (1.2m x 2.4m)	30 sheets/ bundle
SB12XS158P	12.1 PSI (83.4 kPa)	R5 (0.88 RSI)	1-1/2" (38mm)	4' x 8' (1.2m x 2.4m)	20 sheets/ bundle
SB12XS208P	12.1 PSI (83.4 kPa)	R8 (1.41 RSI)	2" (51mm)	4' x 8' (1.2m x 2.4m)	15 sheets/ bundle
SKU #	Compressive Strength	R-value	Thickness	Dimensions	Packaging
SB35XS0508P	35.6 PSI (245.5 kPa)	R2.5 (0.44 RSI)	1/2" (13mm)	4' x 8' (1.2m x 2.4m)	60 sheets/ bundle
SB35XS0758P	35.6 PSI (245.5 kPa)	R3.75 (0.66 RSI)	3/4" (19mm)	4' x 8' (1.2m x 2.4m)	40 sheets/ bundle
SB35XS0759P	35.6 PSI (245.5 kPa)	R3.75 (0.66 RSI)	3/4" (19mm)	4' x 9' (1.2m x 2.7m)	40 sheets/ bundle
SB35XS108P	35.6 PSI (245.5 kPa)	R5 (0.88 RSI)	1" (25mm)	4' x 8' (1.2m x 2.4m)	30 sheets/ bundle
SB35XS109P	35.6 PSI (245.5 kPa)	R5 (0.88 RSI)	1" (25mm)	4' x 9' (1.2m x 2.7m)	30 sheets/ bundle
SB35XS158P	35.6 PSI (245.5 kPa)	R7.5 (1.32 RSI)	1-1/2" (38mm)	4' x 8' (1.2m x 2.4m)	20 sheets/ bundle
SB35XS159P	35.6 PSI (245.5 kPa)	R7.5 (1.32 RSI)	1-1/2" (38mm)	4' x 9' (1.2m x 2.7m)	20 sheets/ bundle
SB35XS208P	35.6 PSI (245.5 kPa)	R10 (1.76 RSI)	2" (51mm)	4' x 8' (1.2m x 2.4m)	15 sheets/ bundle
SB35XS308P	35.6 PSI (245.5 kPa)	R15 (2.64 RSI)	3" (76mm)	4' x 8' (1.2m x 2.4m)	10 sheets/ bundle

\*Metric values serve as nominal conversions. Tables should be used only as a reference. For the most up to date product availability and pricing contact your local sales representatives.

## SilveRboard® Graphite

SKU #	Density	R-value	Thickness	Dimensions	Packaging
SBGXS050008P	0.7 lb/ft <sup>3</sup> (11.2 kg/m <sup>3</sup> )	R2.2 (0.39 RSI)	1/2" (13mm)	4' x 8' (1.2m x 2.4m)	60 sheets/ bundle
SBGXS050009P	0.7 lb/ft <sup>3</sup> (11.2 kg/m <sup>3</sup> )	R2.2 (0.39 RSI)	1/2" (13mm)	4' x 9' (1.2m x 2.7m)	60 sheets/ bundle
SBGXS050010P	0.7 lb/ft <sup>3</sup> (11.2 kg/m <sup>3</sup> )	R2.2 (0.39 RSI)	1/2" (13mm)	4' x 10' (1.2m x 3.0m)	60 sheets/ bundle
SBGXS062508P	0.7 lb/ft <sup>3</sup> (11.2 kg/m <sup>3</sup> )	R2.8 (0.49 RSI)	5/8" (16mm)	4' x 8' (1.2m x 2.4m)	48 sheets/ bundle
SBGXS062509P	0.7 lb/ft <sup>3</sup> (11.2 kg/m <sup>3</sup> )	R2.8 (0.49 RSI)	5/8" (16mm)	4' x 9' (1.2m x 2.7m)	48 sheets/ bundle
SBGXS062510P	0.7 lb/ft <sup>3</sup> (11.2 kg/m <sup>3</sup> )	R2.8 (0.49 RSI)	5/8" (16mm)	4' x 10' (1.2m x 3.0m)	48 sheets/ bundle
SBGXS075008P	0.7 lb/ft <sup>3</sup> (11.2 kg/m <sup>3</sup> )	R3.3 (0.58 RSI)	3/4" (19mm)	4' x 8' (1.2m x 2.4m)	34 sheets/ bundle
SBGXS100008P	0.7 lb/ft <sup>3</sup> (11.2 kg/m <sup>3</sup> )	R4.5 (0.79 RSI)	1" (25mm)	4' x 8' (1.2m x 2.4m)	30 sheets/ bundle
SBGXS100009P	0.7 lb/ft <sup>3</sup> (11.2 kg/m <sup>3</sup> )	R4.5 (0.79 RSI)	1" (25mm)	4' x 9' (1.2m x 2.7m)	30 sheets/ bundle
SBGXS100010P	0.7 lb/ft <sup>3</sup> (11.2 kg/m <sup>3</sup> )	R4.5 (0.79 RSI)	1" (25mm)	4' x 10' (1.2m x 3.0m)	30 sheets/ bundle
SBGXS112508P	0.7 lb/ft <sup>3</sup> (11.2 kg/m <sup>3</sup> )	R5 (0.88 RSI)	1-1/8" (28.5mm)	4' x 8' (1.2m x 2.4m)	27 sheets/ bundle
SBGXS112509P	0.7 lb/ft <sup>3</sup> (11.2 kg/m <sup>3</sup> )	R5 (0.88 RSI)	1-1/8" (28.5mm)	4' x 9' (1.2m x 2.7m)	27 sheets/ bundle
SBGXS112510P	0.7 lb/ft <sup>3</sup> (11.2 kg/m <sup>3</sup> )	R5 (0.88 RSI)	1-1/8" (28.5mm)	4' x 10' (1.2m x 3.0m)	27 sheets/ bundle
SBGXS150008P	0.7 lb/ft <sup>3</sup> (11.2 kg/m <sup>3</sup> )	R6.75 (1.19 RSI)	1-1/2" (38mm)	4' x 8' (1.2m x 2.4m)	20 sheets/ bundle
SBGXS150009P	0.7 lb/ft <sup>3</sup> (11.2 kg/m <sup>3</sup> )	R6.75 (1.19 RSI)	1-1/2" (38mm)	4' x 9' (1.2m x 2.7m)	20 sheets/ bundle
SBGXS150010P	0.7 lb/ft <sup>3</sup> (11.2 kg/m <sup>3</sup> )	R6.75 (1.19 RSI)	1-1/2" (38mm)	4' x 10' (1.2m x 3.0m)	20 sheets/ bundle

\*Metric values serve as nominal conversions. Tables should be used only as a reference. For the most up to date product availability and pricing contact your local sales representatives.



## SilveRboard® Graphite

SKU #	Density	R-value	Thickness	Dimensions	Packaging
SBGXS162508P	0.7 lb/ft <sup>3</sup> (11.2 kg/m <sup>3</sup> )	R7.5 (1.32 RSI)	1-5/8" (41mm)	4' x 8' (1.2m x 2.4m)	18 sheets/ bundle
SBGXS162509P	0.7 lb/ft <sup>3</sup> (11.2 kg/m <sup>3</sup> )	R7.5 (1.32 RSI)	1-5/8" (41mm)	4' x 9' (1.2m x 2.7m)	18 sheets/ bundle
SBGXS162510P	0.7 lb/ft <sup>3</sup> (11.2 kg/m <sup>3</sup> )	R7.5 (1.32 RSI)	1-5/8" (41mm)	4' x 10' (1.2m x 3.0m)	18 sheets/ bundle
SBGXS175008P	0.7 lb/ft <sup>3</sup> (11.2 kg/m <sup>3</sup> )	R7.8 (1.37 RSI)	1-3/4" (45mm)	4' x 8' (1.2m x 2.4m)	18 sheets/ bundle
SBGXS175009P	0.7 lb/ft <sup>3</sup> (11.2 kg/m <sup>3</sup> )	R7.8 (1.37 RSI)	1-3/4" (45mm)	4' x 9' (1.2m x 2.7m)	18 sheets/ bundle
SBGXS175010P	0.7 lb/ft <sup>3</sup> (11.2 kg/m <sup>3</sup> )	R7.8 (1.37 RSI)	1-3/4" (45mm)	4' x 10' (1.2m x 3.0m)	18 sheets/ bundle
SBGXS200008P	0.7 lb/ft <sup>3</sup> (11.2 kg/m <sup>3</sup> )	R9 (1.58 RSI)	2" (51mm)	4' x 8' (1.2m x 2.4m)	14 sheets/ bundle
SBGXS200009P	0.7 lb/ft <sup>3</sup> (11.2 kg/m <sup>3</sup> )	R9 (1.58 RSI)	2" (51mm)	4' x 9' (1.2m x 2.7m)	14 sheets/ bundle
SBGXS200010P	0.7 lb/ft <sup>3</sup> (11.2 kg/m <sup>3</sup> )	R9 (1.58 RSI)	2" (51mm)	4' x 10' (1.2m x 3.0m)	14 sheets/ bundle
SBGXS225008P	0.7 lb/ft <sup>3</sup> (11.2 kg/m <sup>3</sup> )	R10 (1.76 RSI)	2-1/4" (57mm)	4' x 8' (1.2m x 2.4m)	13 sheets/ bundle
SBGXS225009P	0.7 lb/ft <sup>3</sup> (11.2 kg/m <sup>3</sup> )	R10 (1.76 RSI)	2-1/4" (57mm)	4' x 9' (1.2m x 2.7m)	13 sheets/ bundle
SBGXS225010P	0.7 lb/ft <sup>3</sup> (11.2 kg/m <sup>3</sup> )	R10 (1.76 RSI)	2-1/4" (57mm)	4' x 10' (1.2m x 3.0m)	13 sheets/ bundle

\*Metric values serve as nominal conversions. Tables should be used only as a reference. For the most up to date product availability and pricing contact your local sales representatives.



SilveRboard® is a high quality, innovative insulation materials designed for both residential and commercial applications. Competitive pricing, extensive product distribution and excellent technical support are combined to provide our clients with a simplified approach to a superior finished product. If any of your questions or concerns are not completely addressed in this manual, please contact us and our staff will be happy to answer your questions. At Amvic, we pride ourselves in offering our customers an exceptional level of customer service.

#### **Disclaimer**

Information contained in this document is provided as a guideline only, without any warranty of any kind, either expressed or implied, including, but not limited to, the implied warranties of merchantability, fitness for a particular purpose, and freedom of infringement.

This document is provided for informational purposes only. The information contained in this document represents the current views of Amvic Inc. on the issues discussed as of the date of this publication. These opinions, as expressed, should not be interpreted to be a commitment on the part of Amvic Inc. The user assumes the entire risk as to the accuracy and the use of this document.

This manual provides a basic guide for the installation of SilveRboard® and is intended to supplement, rather than replace, the basic construction knowledge of a construction professional. All installations of SilveRboard® must be in accordance with all applicable building codes and/or under the guidance of a licensed professional engineer. In all cases, applicable building code regulations take precedence over this manual.

#### **Technical Support**

Please contact us for any inquiries pertaining to information included in this manual, or if you require any other technical assistance.

Phone 1 (877) 470-9991 (toll free)  
1 (416) 410-5674

Email [support@amvicsystem.com](mailto:support@amvicsystem.com)

The Amvic website is updated regularly with the most current news, including testing reports, technical bulletins and evaluation reports. This document is available both in print and as a downloadable file from [www.amvicsystem.com](http://www.amvicsystem.com)

SilveRboard® is a registered trademark of Amvic Inc.