

Model # DS18968

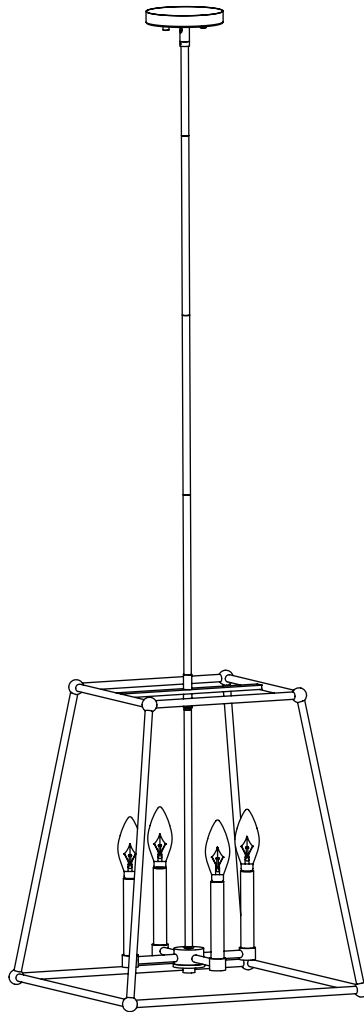

USE AND CARE GUIDE

4-LIGHT PENDANT



Questions or problems? Before returning to the store,
call Design Solutions International Customer Service
Mon-Fri 9:30 am to 3:00 pm EST

1-800-388-6141 ext. 216

For customer service support and the fastest response, please email us at
CustomerSupport@DSLighting.com

Table of Contents

Table of Contents	2	Hardware Included	3
Safety Information	2	Package Contents	4
Warranty	2	Installation	5
Three (3) Year Warranty	2	Care and Cleaning	7
What is Covered	2	Troubleshooting	7
What is Not Covered	2		
Pre-Installation	3		
Planning Installation	3		
Tools Required	3		

Safety Information

READ AND SAVE THESE INSTRUCTIONS.

- For your protection and safety, carefully read and understand the information provided in this manual completely before attempting to assemble, install, or operate this product. Failure to do so could lead to electrical shock, fire, or other injuries that could be hazardous or even fatal.
- Before touching any wire, use a voltage tester to make sure it is not live.
- When replacing fuses, turn off the main power first. Make sure your hands and feet are dry, and place one hand behind your back to prevent electricity from making a complete circuit through your chest. Touch the plug fuse only by its insulated rim. Remove cartridge fuses with a fuse puller.
- Use tools with insulated handles and ladders made of wood or fiberglass.
- To protect children, place a safety cover over any unused outlets.



DANGER: Before starting installation of this fixture or removal of a previous fixture, disconnect the power by turning off the circuit breaker, removing the fuse at the fuse box, or tripping the breaker that controls that circuit. Tape a sign to the panel warning others to leave the circuit alone while you work.



CAUTION: CONSULT A QUALIFIED ELECTRICIAN IF YOU HAVE ANY ELECTRICAL QUESTIONS. If you have any non-electrical questions about this fixture, please call our Customer Service Team at 1-800-388-6141 ext. 216. Please reference your model (DS18968) or UPC (802513189681).

Warranty

THREE (3) YEAR WARRANTY

WHAT IS COVERED

The manufacturer warrants this fixture to be free from defects in materials and workmanship for a period of three (3) years from date of purchase. This warranty applies only to the original consumer purchaser and only to products used in normal use and service. If this product is found to be defective, the manufacturer's only obligation, and your exclusive remedy, is the repair or replacement of the product at the manufacturer's discretion, provided that the product has not been damaged through misuse, abuse, accident, modifications, alteration, neglect, or mishandling. This warranty shall not apply to any product that is found to have been improperly installed, set-up, or used in any way not in accordance with the instructions supplied with the product. This warranty shall not apply to a failure of the product as a result of an accident, misuse, abuse, negligence, alteration, faulty installation, or any other failure not relating to faulty material or workmanship. This warranty shall not apply to the finish on any portion of the product, such as surface and/or weathering, as this is considered normal wear and tear.

WHAT IS NOT COVERED

The manufacturer does not warrant and specifically disclaims any warranty, whether expressed or implied, of fitness for a particular purpose, other than the warranty contained herein. The manufacturer specifically disclaims any liability and shall not be liable for any consequential or incidental loss or damage, including but not limited to any labor/expense costs involved in the replacement or repair of said product.

Contact the Customer Service Team at 1-800-388-6141 ext. 216 Eastern Time, Mon-Fri 9:30 am to 3:00 pm EST. For customer service support and the fastest response, please email us at CustomerSupport@DSILighting.com.

Pre-Installation

PLANNING INSTALLATION

Read all instructions before installing.

To avoid damaging this product, place it on a soft, non-abrasive surface, such as carpet or cardboard.



IMPORTANT: Inspect the wire insulation for any cuts, abrasions, or exposed copper that may have occurred during shipping. If there is a defect in the wire, do not attempt installation. Please call the Customer Service Team at 1-800-388-6141 ext. 216. For customer service and the fastest response, please email us at CustomerSupport@DSILighting.com.



NOTE: This product requires four 60W maximum candelabra base (E12) type "B" bulbs or 9W maximum candelabra base (E12) self-ballasted LED bulbs (sold separately).

TOOLS REQUIRED (NOT INCLUDED)

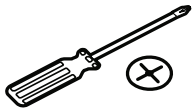

Phillips Screwdriver



Wire Stripper



Pliers



Safety Goggles



Electrical Tape

HARDWARE INCLUDED



NOTE: Hardware not shown to actual size.

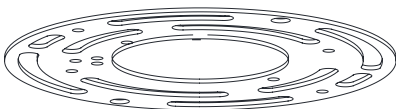

AA

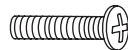

BB

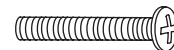

CC



DD



EE



FF



GG

Part	Description	Quantity
AA	Mounting bracket	1
BB	Outlet box screw (short)	2
CC	Support screw (long)	2
DD	Hex nut	2

Part	Description	Quantity
EE	Green ground screw (Pre-assembled to mounting bracket (AA))	1
FF	Wire connector	3
GG	Cap nut	2

Pre-Installation (continued)

PACKAGE CONTENTS

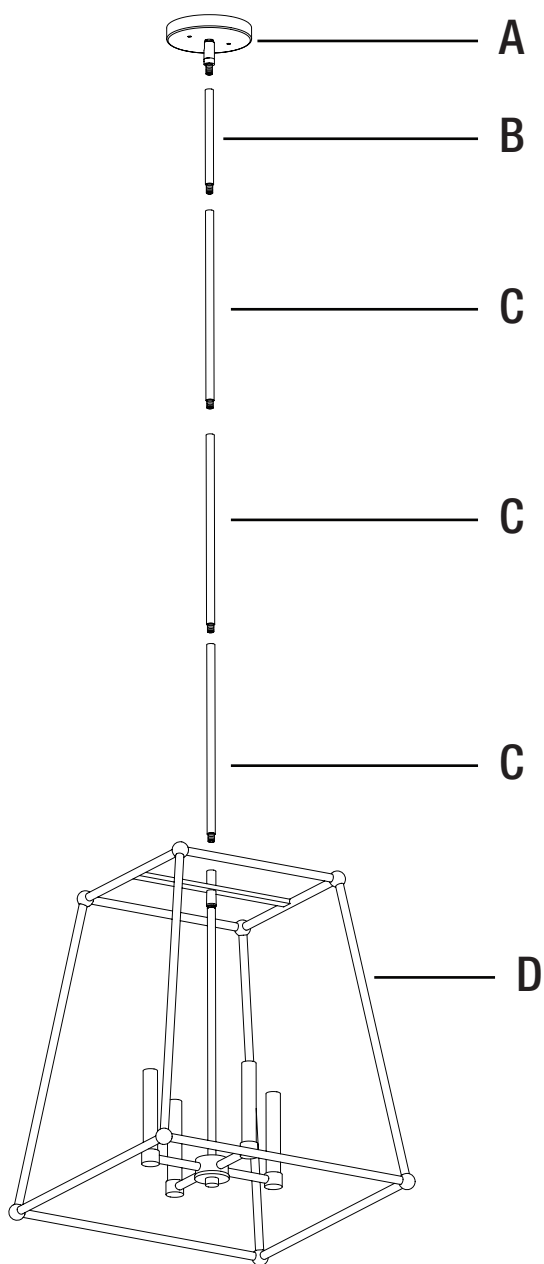

Part	Description	Quantity
A	Canopy assembly	1
B	6" Tube	1
C	12" Tube	3
D	Fixture body	1

Installation

1 Preparing the mounting bracket

- Fasten the support screws (long) (CC) into the mounting bracket (AA), and secure it using the hex nuts (DD).



NOTE: The support screws (long) (CC) should extend long enough to protrude through the canopy assembly (A) when it is mounted. (Adjust as needed.)

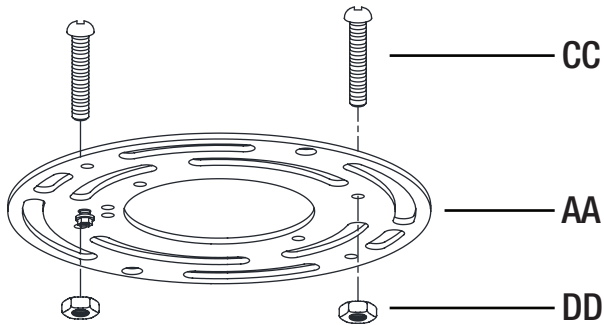

2 Installing the mounting bracket

- Fasten the mounting bracket (AA) onto the outlet box using two outlet box screws (short) (BB).

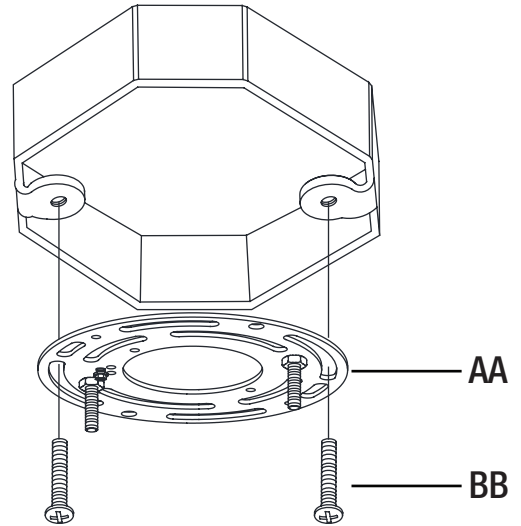

3 Assembling the tubes and canopy assembly to the fixture body

- Guide the fixture wire with the bare copper ground wire through the tubes (B,C,) and the canopy assembly (A).
- Tighten the canopy assembly (A) and the tubes (B,C,) together onto the fixture body (D) until secured respectively as shown in the diagram.
- There are seven different height options for the user to chose from:

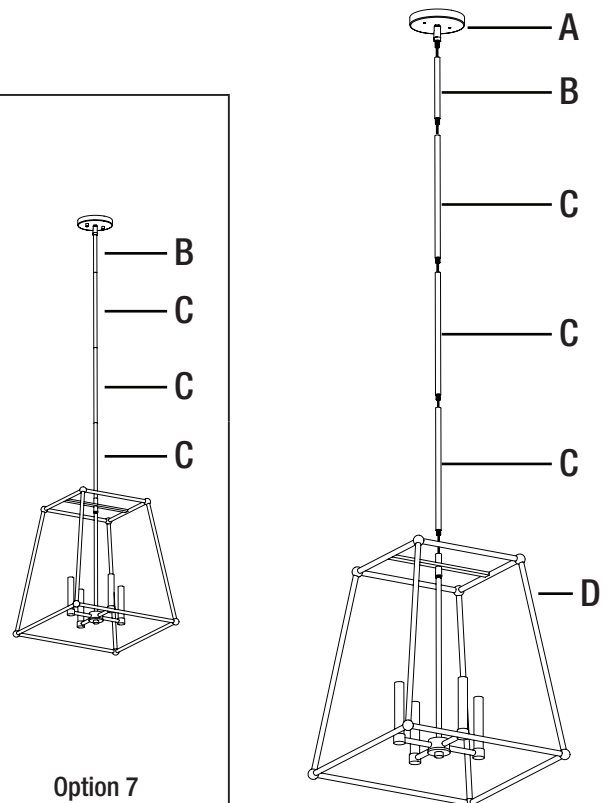
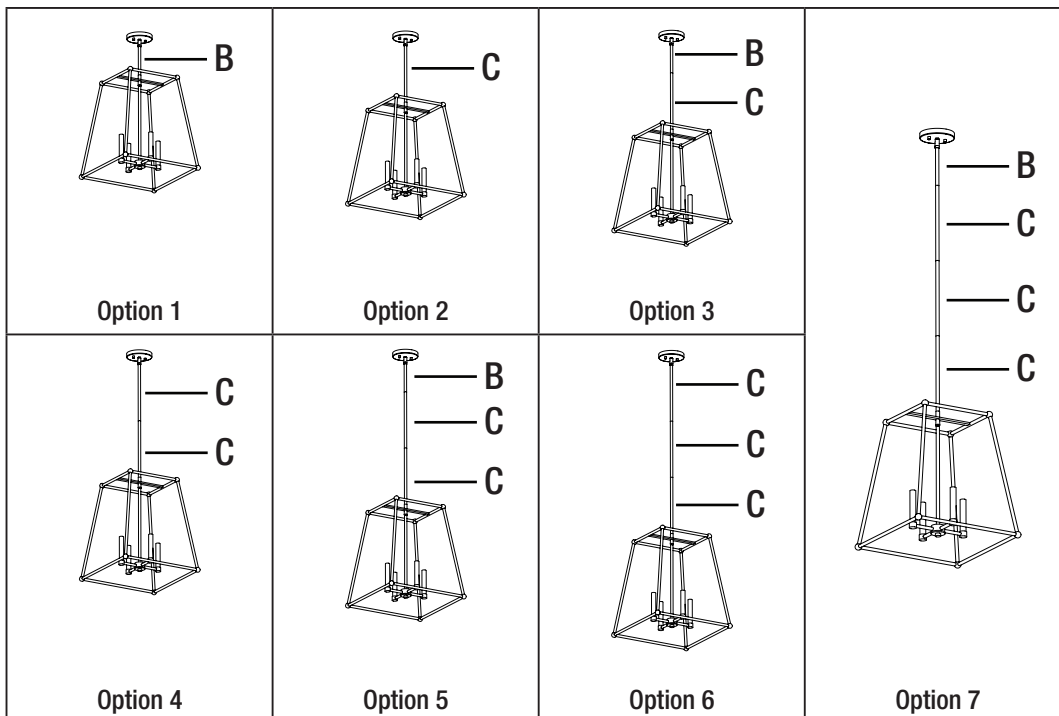

Installation (continued)

4 Making the electrical connections

- Strip 3/4 in. of insulation from the wire ends.
- Connect the black wire from the fixture to the black wire from the outlet box, then connect the white wire from the fixture to the white wire from the outlet box.
- The bare copper ground wire from the fixture must loop one turn under the head of the green ground screw (EE) on the mounting bracket (AA) before it is connected to the ground conductor of the supply circuit.
- Cover the wires with wire connectors (FF). Tape the wire connectors (FF) and wires together, and carefully position all wires inside the outlet box.

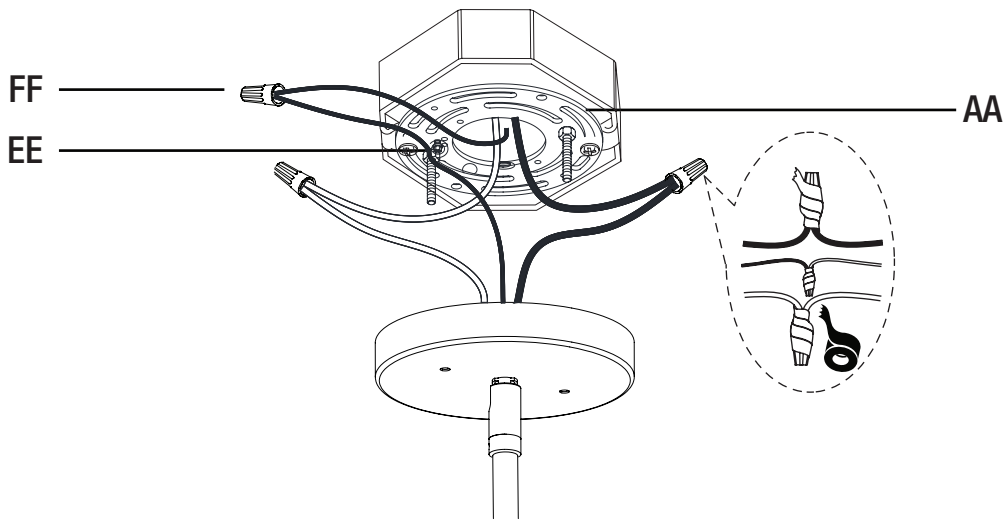

5 Assembling the canopy assembly to the outlet box

- Place the canopy assembly (A) over the outlet box, and ensure the heads of the support screws (long) (CC) come through the holes of the canopy assembly (A).
- Tighten the cap nuts (GG) onto the protruding support screws (long) (CC) on the mounting bracket (AA) until the canopy assembly (A) is held firmly against the ceiling.

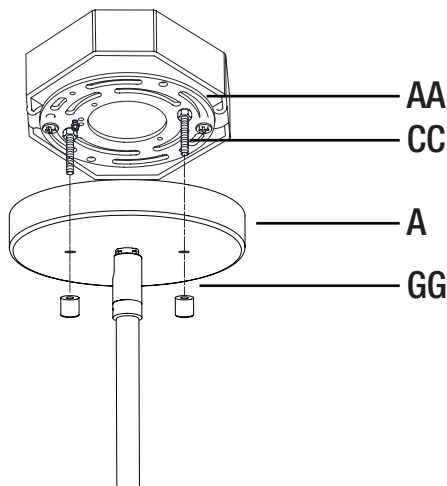

6 Installing the light bulbs

- Install the light bulbs (not included) into the sockets. Use four 60-watt candelabra base (E12) type "B" bulbs (recommended).



NOTE: You can also use four 9W maximum candelabra base (E12) self-ballasted LED bulbs (sold separately). Do not exceed the recommended wattage.

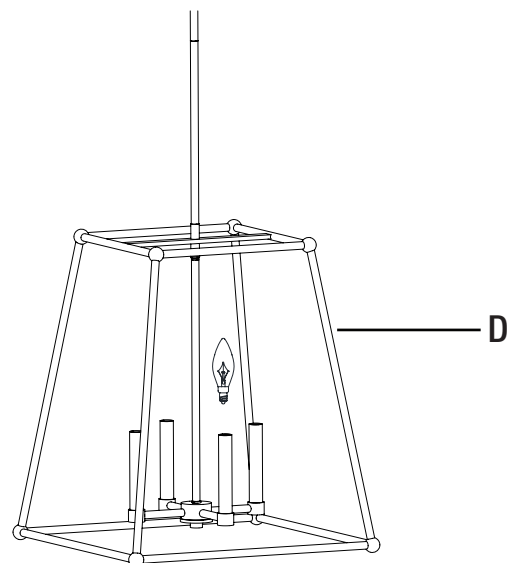

Care and Cleaning

- Do not use any cleaners with chemicals, solvents, or harsh abrasives. Use only a dry, soft cloth to dust or wipe carefully.
- To clean the fixture, disconnect power by turning off the circuit breaker or by removing the fuse at the fuse box. Use a dry or slightly dampened, clean cloth to wipe the exterior surface of the fixture.

Troubleshooting

Problem	Possible Cause	Solution
The lights will not turn on.	The bulb is burned out.	Replace the light bulb.
	The power is off.	Ensure the power supply is turned on.
	There is a faulty switch.	Test or replace the switch.
	There is a faulty wire connection.	Check the wiring.
The fuse blows or the circuit breaker trips when the light is turned on.	There are crossed wires or the power wire is grounding out.	Discontinue use of the lamp. Check the wire connections. Contact a qualified electrician or call the Customer Service Team at 1-800-388-6141 ext. 216. For customer service and the fastest response, please email us at CustomerSupport@DSILighting.com .



Questions or problems? Before returning to the store,
call Design Solutions International Customer Service
Mon-Fri 9:30 am to 3:00 pm EST

1-800-388-6141 ext. 216

For customer service support and the fastest response, please email us at

CustomerSupport@DSLighting.com

Retain this manual for future use.