

get started

INSTANT® SOLO COFFEE MAKER

Instant®

Welcome

Welcome to your new Instant Solo Coffee Maker!

Whether it's a Keurig K-Cup®* pod or your favorite ground coffee, you can brew a delicious cup of café-quality coffee quickly and in your own home!

⚠ WARNING

Before using your Instant Solo Coffee Maker, read all instructions, including the Safety Information on pages 4-6 and Warranty on pages 18-19. Failure to follow the safeguards and instructions may result in injury and/or property damage.

** K-Cup is a registered trademark of Keurig Green Mountain, Inc. Use of the K-Cup trademark does not imply any affiliation with or endorsement by Keurig Green Mountain, Inc.*

Table of Contents

Welcome	2
Safety Warnings	4
What's in the box?.....	7
Your Instant Solo Coffee Maker	8
Before you brew	11
Brewing Coffee	13
Care, Cleaning, Storage	15
Learn more	17

This device complies with Part 15 of the FCC Rules. Operation is subject to the following two conditions: (1) this device may not cause harmful interference, and (2) this device must accept any interference received, including interference that may cause undesired operation. Changes or modifications not expressly approved by the part responsible for compliance could void the user's authority to operate the equipment.

NOTE: "This equipment has been tested and found to comply with the limits for a Class B digital device, pursuant to part 15 of the FCC Rules. These limits are designed to provide reasonable protection against harmful interference in a residential installation. This equipment generates, uses and can radiate radio frequency energy and, if not installed and used in accordance with the instructions, may cause harmful interference to radio communications. However, there is no guarantee that interference will not occur in a particular installation. If this equipment does cause harmful interference to radio or television reception, which can be determined by turning the equipment off and on, the user is encouraged to try to correct the interference by one or more of the following measures:

- Reorient or relocate the receiving antenna.
- Increase the separation between the equipment and receiver.
- Connect the equipment into an outlet on a circuit different from that to which the receiver is connected.
- Consult the dealer or an experienced radio/TV technician for help.

IMPORTANT SAFEGUARDS

SAFETY WARNINGS

⚠ WARNING

Read all instructions before using and only use this appliance as directed. Failure to follow these Important Safeguards may result in injury and/or property damage and will void your warranty.

When using electrical appliances, basic safety precautions should always be followed to reduce the risk of fire, electric shock, and injury to persons.

Placement

- **DO** operate the appliance on a stable, non-combustible, level surface.
- **DO NOT** place the appliance on or near a hot gas or electric burner, or in a heated oven.

General Use

- **DO NOT** use this coffee maker outdoors.
- **DO NOT** fill the water tank with mineral water, milk or other liquids. Only fill the water tank with clean, cold water.
- **DO NOT** let the coffee maker operate without water.
- **DO NOT** use the appliance for anything than its intended use. Not for commercial use. For household use only.
- **DO** regularly inspect the appliance and power cord.
- **DO** only fill the water tank with clean, cold water.
- **DO NOT** fill the water tank with mineral water, milk or other liquids.
- **DO NOT** leave the appliance exposed to sun, wind, and/or snow.
- **DO** operate and store the appliance above 32°F / 0°C
- **DO NOT** leave the appliance unattended when in use.
- **DO NOT** allow children operate the appliance; close supervision is required when any appliance is used near children.
- **DO NOT** let children play with this appliance.
- **DO NOT** force the pod into the appliance. Only use pods intended for this appliance.
- To avoid the risk of extremely hot water, **DO NOT** open the top cover during the brew process. There is extremely hot water in the brewing chamber during the brew process.
- **DO NOT** touch hot surfaces. Use handles or knobs.

The use of an accessory not evaluated for use with this appliance may cause injuries.

See instructions regarding closing the Brew Chamber on Page 14.

SAFETY WARNINGS

⚠ WARNING

Care and Storage

- **DO** unplug from outlet when not in use before cleaning. Allow the appliance to cool before putting on or taking off parts, and before cleaning the appliance.
- **DO NOT** store any materials in the brewing chamber when not in use.

Power Cord

- A short power-supply cord is used to reduce the risk resulting from it being grabbed by children, becoming entangled in, or tripping over a longer cord.

⚠ WARNING

Spilled liquids from this coffee maker can cause serious burns. Keep appliance and cord away from children.

Never drape cord over edge of counter and never use outlet below counter.

- **DO NOT** let the power cord touch hot surfaces or open flame, including the stovetop.
- **DO NOT** use with power converters or adapters, timer switches or separate remote-control systems.
- **DO NOT** let the power cord hang over the edge of tables or counters.
- **DO** unplug your coffee maker by grasping the plug and pull from the outlet. Never pull from the power cord.
- **DO NOT** attempt to modify the plug. If the plug does not fit full into the outlet, reverse the plug.
- **DO** contact a qualified electrician if the plug does not fit in the outlet.
- **DO** plug this appliance into a polarized outlet one way. This appliance has a polarized plug, and one blade is wider than the other.

This appliance has a polarized plug, with one blade wider than the other. To reduce the risk of electrical shock:

- **ONLY** plug this appliance into a polarized outlet. If the plug does not fit fully into the outlet, reverse the plug.
- **DO NOT** attempt to modify the plug in any way. If it still does not fit, contact a qualified electrician.

SAFETY WARNINGS

⚠ WARNING

Electrical Warning

The coffee maker contains electrical components that are an electrical shock hazard. Failure to follow these instructions may result in electric shock.

To protect against electrical shock:

- To reduce the risk of fire or electric shock, do not remove the bottom cover. No user-serviceable parts inside. Repair should be done by authorized service personnel only.
- To disconnect, turn any control to the off position and remove plug from power source. Always unplug when not in use, as well as before adding or removing parts or accessories, and before cleaning. To unplug, grasp the plug and pull from the outlet. Never pull from the power cord.
- **DO** regularly inspect the appliance and power cord. **DO NOT** operate the appliance if the power cord or plug is damaged, or after the appliance malfunctions or is dropped or damaged in any manner. For assistance, contact Customer Care by email at support@instanthome.com or by phone at 1-800-828-7280.
- **DO NOT** attempt to repair, replace or modify components of the appliance, as this may cause electric shock, fire or injury, and will void the warranty.
- **DO NOT** tamper with any of the safety mechanisms, as this may result in injury or property damage.
- **DO NOT** immerse power cord, plug or the appliance in water or other liquid.
- **DO** plug this appliance into a polarized outlet one way. This appliance has a polarized plug, and one blade is wider than the other.
- **DO NOT** use the appliance in electrical systems other than 120 V ~ 60 Hz for North America.
- If a long detachable power-supply cord or extension cord is used:
 - The marked electrical rating of the detachable power-supply cord or extension cord should be at least as great as the electrical rating of the appliance.
 - The longer cord should be arranged so that it will not drape over the countertop or tabletop where it can be pulled on by children or tripped over.

SAVE THESE INSTRUCTIONS

What's in the box?

Instant Solo Single-Serve Coffee Maker

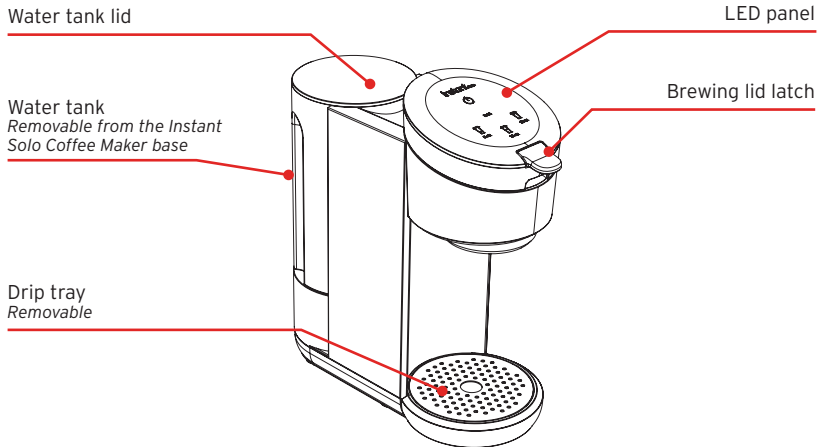

Reusable Coffee Pod with Handle

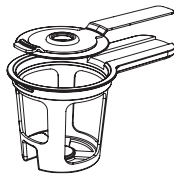

Illustrations are for reference only and may differ from the actual product.

Your Instant Solo Coffee Maker

Remember to recycle!

We designed our packaging with sustainability in mind. Be sure to recycle at a recycling center in your area.

Control panel

Here's a look at the simple-to-use, easy-to-read Instant Solo Coffee Maker control panel.

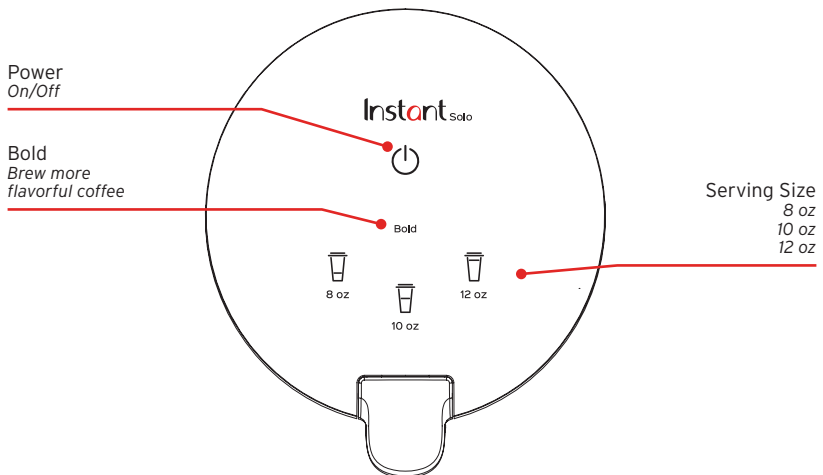

Your Instant Solo Coffee Maker

Plug-in and time-out

Once you plug in your Instant Solo Coffee Maker, you'll hear a beep. Press the power button (located above **Bold**) to turn on your Solo – the LED buttons should light up.

After 30 minutes of inactivity, your coffee maker will enter standby mode. The LED control panel will dim. After another 2 hours of inactivity, the LED panel will shut off.

Sound Settings

You can turn button-pressing sounds and reminder beeps on or off.

1. Make sure your Instant Solo is on.
2. Press and hold the **8 oz** and **12 oz** buttons at the same time for 3 seconds.
3. Wait for the **8 oz** and **12 oz** buttons to blink twice.

Note: The device failure sound cannot be deactivated

Your Instant Solo Coffee Maker

Altitude Mode

If you're using the Instant Solo Coffee Maker at +5,000 feet sea level, enable **Altitude Mode** before you brew.

To turn **Altitude Mode** on

1. Make sure your Instant Solo is on.
2. Press and hold the 8 oz and 10 oz buttons for 3 seconds.
3. Wait until the 8 oz and 10 oz buttons blink twice.

To turn **Altitude Mode** off

1. Make sure your Instant Solo is on.
2. Press and hold the 8 oz and 10 oz buttons for 3 seconds.
3. Wait until the 8 oz and 10 oz buttons blink three times.

Water Empty Alert

Your Instant Solo will let you know when the water tank is empty or nearly out of water. When this happens, you'll hear a beep, brewing will stop, and the LED control panel will flash. At this point, refill the water tank and exit the alert mode by pressing any button.

Before you brew

Initial set up

1. Pull the Instant Solo coffee maker and all accessories out of the box.
2. Remove all packaging materials from within and around the Instant Solo Coffee Maker.
3. Place your Solo on a dry, stable, and level surface.
4. Lift the water tank up and remove the foam cushion from underneath the water tank.
5. Place water tank back on the coffee maker base.
6. Plug in your Instant Solo Coffee Maker.

Clean before use

1. Lift the water tank up to remove from Instant Solo Coffee Maker.
2. Handwash the water tank and reusable coffee pod with warm water and dish soap. Rinse with warm, clear water.
3. Wipe the water tank and accessories with a clean, dry cloth.
4. With a damp cloth, wipe down the coffee maker base and control panel.

Before you brew

Initial Cleaning

Before you brew your first cup of coffee, clean your Instant Solo Coffee Maker. Run the following cleaning program without a coffee pod or the reusable coffee pod.

1. Lift the water tank from the back of the coffee maker and remove the water tank lid.
2. Fill the water tank with cold water to the **MAX** fill line as indicated on the water tank.
3. Put the lid back onto the water tank and place the water tank back onto the coffee maker.
4. Place a large mug which can hold at least 10 oz of liquid beneath the brew spout and onto the drip tray.
5. Ensure the brewing lid is closed and securely latched. Press **8 oz** button. The key flashes as the water heats.
6. The **8 oz** button will illuminate. The coffee maker begins a brewing cycle and hot water will pour from the brew spot. After the brewing cycle ends or is cancelled and the water stops dripping from the spout, discard the water in the mug. *To **stop brewing at any time**, touch **8 oz** again.*
7. Place the mug back on the drip tray.
8. Touch **10 oz**. The button flashes as the water heats.
9. The **10 oz**. button will illuminate. The coffee maker begins a brewing cycle and hot water will pour from the brew spot. After the brewing cycle ends or is cancelled and the water stops dripping from the spout, discard the water in the mug. *To **stop brewing at any time**, touch **10 oz** again.*

⚠ WARNING

Be careful: Brewing reaches high temperatures. **DO NOT** touch the brewing housing unit or spout during the brewing process. Touching hot surfaces may result in personal injury and/or property damage.

Brewing Coffee

Brewing Coffee

Once you've cleaned your Instant Solo Coffee Maker and water tank, and you've first run cleaning program, you can begin brewing a delicious cup of coffee.

Bold

This program lets you brew a more flavorful cup of coffee by increasing brewing time, allowing the water to extract more flavor from your coffee grounds or coffee pod.

Altitude Mode

If you live at higher altitudes (over 5000 feet above sea level), be sure you follow the instructions on page 10 so your coffee maker works properly.

Reusable Coffee Pod and Coffee Pods

With the Instant Solo Coffee Maker, you can brew coffee with a K-Cup® pod, or grind your favorite coffee beans and use the included reusable coffee pod. Scoop about 2 tablespoons of medium to medium-fine ground coffee into the reusable coffee pod.

Brewing Coffee

How to brew coffee

Prep

1. Fill the water tank up to the **MAX** fill line. *DO NOT attempt to brew if the water level is below the **MIN** fill line.*
2. If you're using coffee beans, grind them down to a medium or medium-fine consistency. *To open the reusable coffee pod, pull up on the metal handle.*

Brew

1. Lift the brewing lid latch and place the reusable coffee pod or K-cup® pod in the brewing housing container.
2. Close the brewing lid, ensuring it is securely latched.
3. For a stronger cup of coffee, press **Bold** before selecting brew size.
4. Select the desired amount of coffee you would like to brew by pressing the **8 oz**, **10 oz** or **12 oz** buttons. The selected button will flash while water heating cycle begins. *You can stop brewing at any time by pressing the selected cup size again.*
5. The selected brewing cup size LED will remain illuminated when the coffee maker starts brewing. Soon, hot water will pour from the brew spout.
6. When the water stops dripping from the spout, lift the lid latch and discard the coffee pod or contents within the reusable coffee pod.
7. Enjoy your freshly brewed cup of coffee.

⚠ WARNING

Be careful: Brewing reaches high temperatures. **DO NOT** touch the brewing housing unit or spout during the brewing process. Touching hot surfaces may result in personal injury and/or property damage.

Care, Cleaning, Storage

Clean your Instant Solo Coffee Maker regularly to ensure the best possible flavor and to prevent mineral deposits from building up in the coffee maker.

Always unplug the coffee maker and let it cool to room temperature before cleaning. Never use metal scouring pads, abrasive powders, or harsh chemical detergents on any of the coffee maker's parts.

Let all parts dry thoroughly before use, and before storage.

Instant Solo Part/ Accessory	Cleaning methods and instructions
Water tank	Remove the tank and handwash with dish soap and warm water.
Reusable coffee pod	Remove and handwash with dish soap and warm water or place in the top rack of a dishwasher.
Stainless steel drip tray	Can be removed and washed by hand with dish soap and warm water or placed in the top rack of a dishwasher.
Coffee maker / LED panel	Use a damp dish cloth to clean the outside of the coffee maker and LED panel
Power cord	DO NOT fold power cord when storing.

⚠ WARNING

Be careful: The coffee maker contains electrical components.

To avoid fire, electric shock, or personal injury:

- Hand wash only.
- **DO NOT** rinse or immerse the coffee maker, power cord, or plug in water or other liquids.

Care, Cleaning, Storage

Descaling / Removing Mineral Deposits

With regular use minerals may accumulate in the coffee maker, which can affect the temperature and strength of your brew.

To make sure your coffee maker stays in tip top shape, descale it regularly to keep mineral deposits from building up.

After 300 cycles, the 10 oz and 12 oz keys flash to remind you to clean and descale your coffee maker.

Descaling Solution Ratio

Cleaner	Cleaner to water ratio
Household descaler	1 : 4
Citric acid	3 : 100

1. Combine cleaner and water as shown in the table above.
2. Make sure the reusable pod is in the brewing housing unit.
3. Fill the water tank to the **MAX** line with the cleaning mixture.
4. Place a large container beneath the drop nozzle. Ensure the brewing lid is securely latched before continuing to step 5.
5. Touch and hold the **10 oz** and **12 oz** keys for 3 seconds. *The cleaning mixture runs through the appliance until the water tank is empty.*
6. Discard the cleaning mixture from the container and place the emptied container beneath the drip nozzle.
7. Rinse the water tank and fill to the **MAX** line with cool, clean water.
8. Touch and hold the **10 oz** and **12 oz** keys for 3 seconds. *The cleaning mixture runs through the appliance until the water tank is empty.*
9. Discard water produced from coffee maker.

⚠ WARNING

Be careful: Hot water is used for descaling. To avoid risk of personal injury and/or property damage, the container must be large enough to hold the **entire contents of the water tank** (40 oz / ~ 1183 mL). Any other servicing should be performed by an authorized service representative.

Learn more

There's a whole world of Instant Solo Coffee Maker information and help just waiting for you. Here are some of the most helpful resources.

Register your product

Instanthome.com/register

Contact Consumer Care

Instanthome.com

support@instanthome.com

1-800-828-7280

Replacement parts and accessories

Instanthome.com

Connect and Share



Product specifications

Model	Volume	Wattage	Power	Weight	Dimensions
SSCM-1000	40 oz / 1183 mL water tank	1250 watts	120V/ 60Hz	2.1 kg 4.63 lbs.	in: 12.6 H x 5.3 W x 11.8 D cm: 32 H x 13.5 W x 30 D

Warranty

One (1) Year Limited Warranty

This One (1) Year Limited Warranty applies to purchases made from authorized retailers of Instant Brands Inc. (“Instant Brands”) by the original appliance owner and is not transferable. Proof of original purchase date and, if requested by Instant Brands, return of your appliance, is required to obtain service under this Limited Warranty. Provided the appliance was used in accordance with the use & care instructions, Instant Brands will, in its sole and exclusive discretion, either: (i) repair defects in materials or workmanship; or (ii) replace the appliance. In the event that your appliance is replaced, the Limited Warranty on the replacement appliance will expire twelve (12) months from the date of receipt. Failure to register your product will not reduce your warranty rights. The liability of Instant Brands, if any, for any allegedly defective appliance or part will not exceed the purchase price of a comparable replacement appliance.

What is not covered by this warranty?

1. Products purchased, used, or operated outside of the United States and Canada.
2. Products that have been modified or attempted to be modified.
3. Damage resulting from accident, alteration, misuse, abuse, neglect, unreasonable use, use contrary to the operating instructions, normal wear and tear, commercial use, improper assembly, disassembly, failure to provide reasonable and necessary maintenance, fire, flood, acts of God, or repair by anyone unless directed by an Instant Brands representative.
4. Use of unauthorized parts and accessories.
5. Incidental and consequential damages.
6. The cost of repair or replacement under these excluded circumstances.

Warranty

EXCEPT AS EXPRESSLY PROVIDED HEREIN AND TO THE EXTENT PERMITTED BY APPLICABLE LAW, INSTANT BRANDS MAKES NO WARRANTIES, CONDITIONS OR REPRESENTATIONS, EXPRESS OR IMPLIED, BY STATUTE, USAGE, CUSTOM OF TRADE OR OTHERWISE WITH RESPECT TO THE APPLIANCES OR PARTS COVERED BY THIS WARRANTY, INCLUDING BUT NOT LIMITED TO, WARRANTIES, CONDITIONS, OR REPRESENTATIONS OF WORKMANSHIP, MERCHANTABILITY, MERCHANTABILITY, FITNESS FOR A PARTICULAR PURPOSE OR DURABILITY.

Some states or provinces do not allow for: (1) the exclusion of implied warranties of merchantability or fitness; (2) limitations on how long an implied warranty lasts; and/or (3) the exclusion or limitation of incidental or consequential damages; so these limitations may not apply to you. In these states and provinces, you have only the implied warranties that are expressly required to be provided in accordance with applicable law. The limitations of warranties, liability, and remedies apply to the maximum extent permitted by law. This limited warranty gives you specific legal rights, and you may also have other rights which vary from state to state or province to province.

Product Registration

Please visit www.instanthome.com/register to register your new Instant Brands™ appliance. Failure to register your product will not diminish your warranty rights. You will be asked to provide the store name, date of purchase, model number (found on the back of your appliance) and serial number (found on the bottom of your appliance) along with your name and email address. The registration will enable us to keep you up to date with product developments, recipes and contact you in the unlikely event of a product safety notification. By registering, you acknowledge that you have read and understand the instructions for use, and warnings set forth in the accompanying instructions.

Warranty Service

To obtain warranty service, please contact our Customer Care Department by phone at 1-800-828-7280 or by email to support@instanthome.com. You can also create a support ticket online at www.instanthome.com. If we are unable to resolve the problem, you may be asked to send your appliance to the Service Department for quality inspection. Instant Brands is not responsible for shipping costs related to warranty service. When returning your appliance, please include your name, mailing address, email address, phone number, and proof of the original purchase date as well as a description of the problem you are encountering with the appliance.

Instant Brands Inc.
495 March Road, Suite 200
Kanata, Ontario, K2K 3G1 Canada

instanthome.com

© 2021 Instant Brands Inc.
140-6012-01-0101