

HOTSHOT HD

COMMERCIAL BROADCAST SPREADER

HOTSHOT
HD

Meyer[®]

MODEL 38140

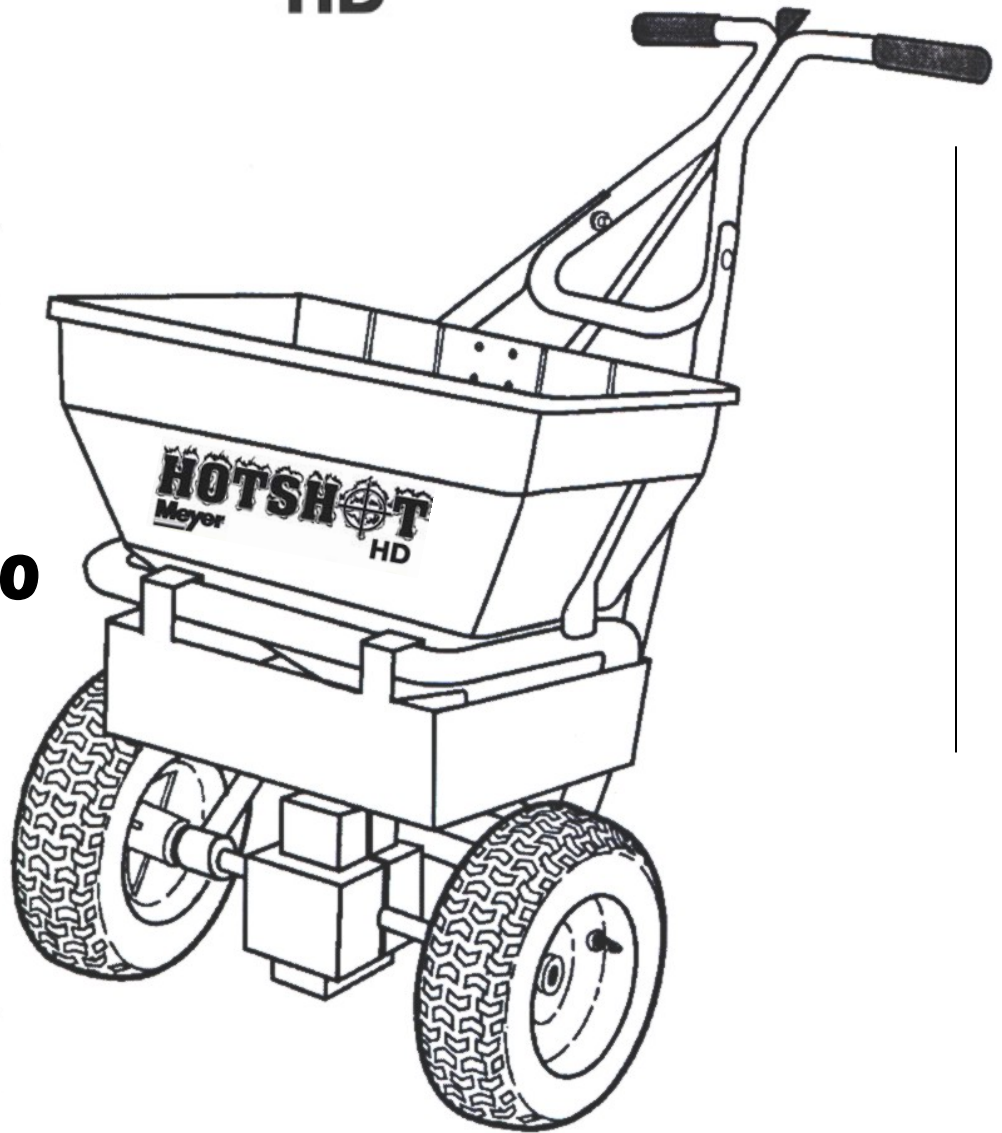

OWNER'S MANUAL

ASSEMBLY INSTRUCTIONS

1. Remove the spreader and components from carton and place hopper up-side down on a padded surface as shown. Slide drive and free wheel onto axle as shown with the longer portion of wheel hub facing the frame. Secure free wheel with (1) 1/8 dia. x 1 1/4" cotter pin. Attach drive wheel to axle with (1) 3/16 dia. x 2" cotter pin.

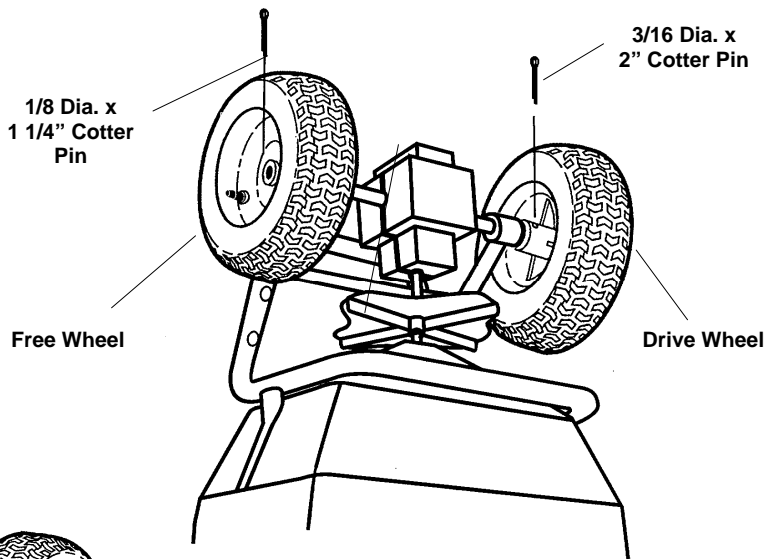

2. Attach leg/brace to frame as shown using (4) 1/4-20 x 2 1/2" carriage bolts and locknuts.

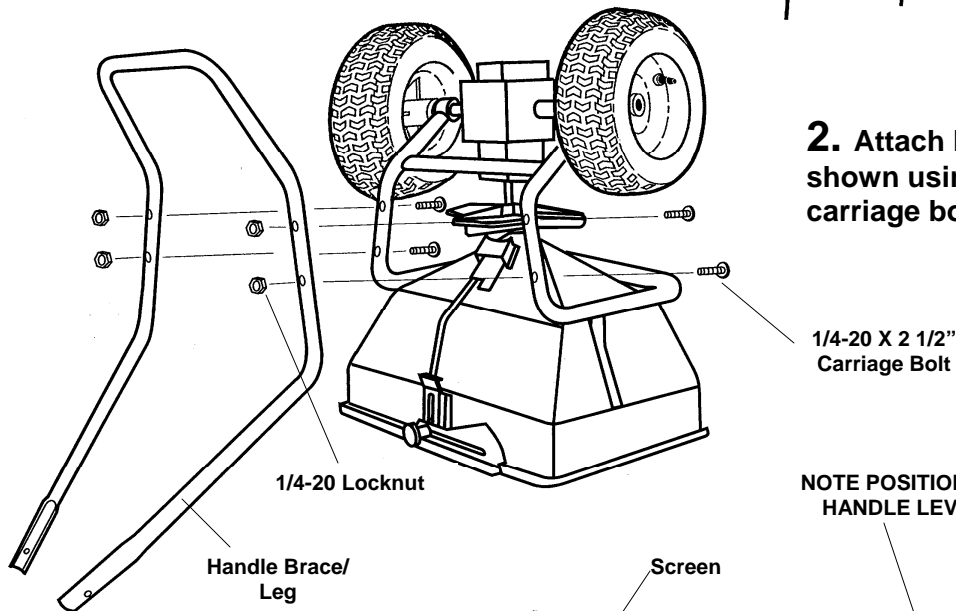

3. Turn spreader upright on wheels. Insert screen into hopper sliding it under the screen clips. Attach the upper handle assembly to handle brace with the handle lever facing as shown. Secure with (2) 1/4-20 x 1 1/2" carriage bolts, and locknuts. Install control tube to handle lever with (1) 1/4 dia. clevis pin and a 3/32" dia. cotter pin. Slip opposite end of control tube over lower control rod making sure shutoff plate is between the lower rod and the control tube. Secure with a 3/32" dia. Hitch pin cotter.

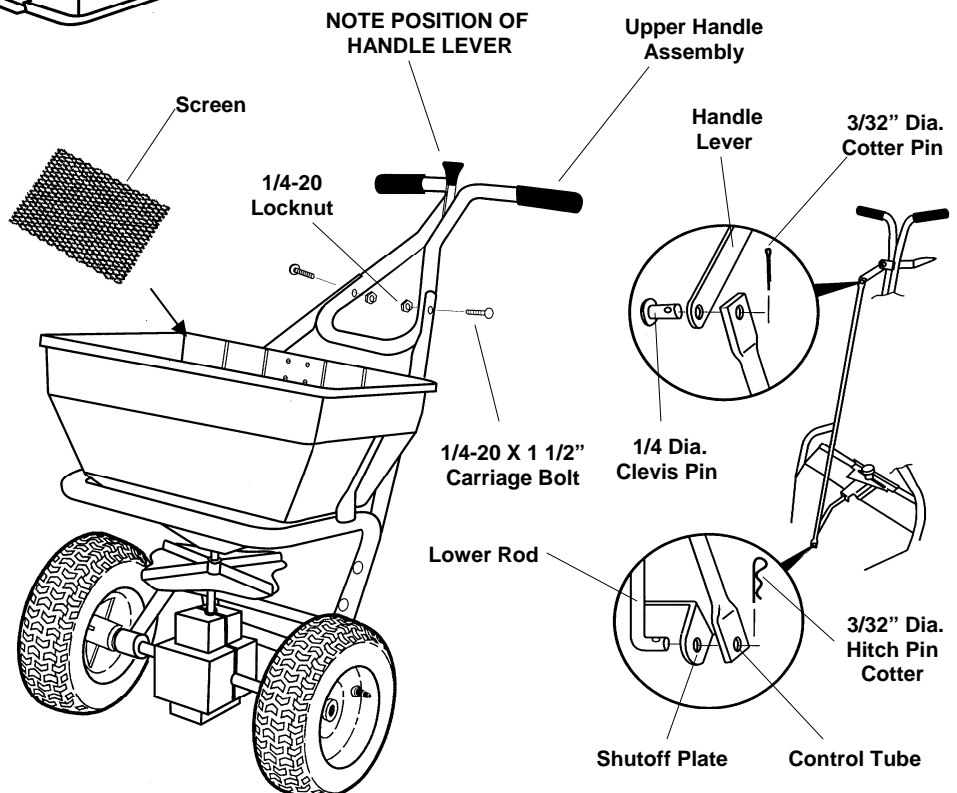

4. Hold the ends of the deflector open slightly to clear the spreader frame in the back. Hang the deflector onto the spreader bumper bar. Align the slots in the back of deflector with the top frame bolts and secure both sides of the deflector with washers and wing nuts. To remove, simply loosen the wing nuts, spread the deflector slightly to clear the frame, and slide the deflector off. Retighten wing bolts.

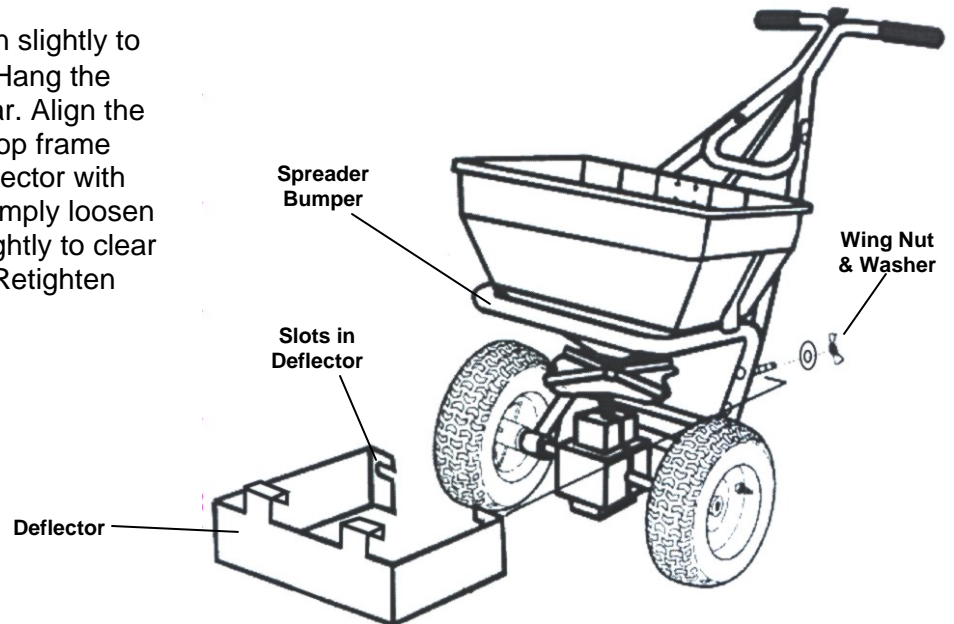

OPERATION

NOTE: This spreader is equipped with a deflector shield that is used for applying ice melt to narrow areas. Shield is easily removed for ice melt application to large areas or when using turf care products.

1. Check the product package for the rate setting, and recommended swath width. Loosen rate control knob and slide rate plate to the proper setting. The pattern is controlled by loosening the two knobs on the discharge chute and moving the chute closer or farther away from the impeller (setting A, B, or C). See "PATTERN ADJUSTMENT" for details.

2. Always fill the spreader on the driveway or sidewalk-not on the lawn. Make sure screen is in hopper and spreader is in the "OFF" position.

3. Start spreader moving before opening port. Close before stopping. Always push spreader, never pull.

4. Hold handle so top of spreader is level. Tipping the spreader too far can cause uneven spreading.

5. The settings and swath widths on the product label are recommended starting points. Always check the delivery rate and pattern on a small area before treating a large area. Actual delivery rate can vary due to weather conditions, operating variables, and condition of the product being applied. See "HOW TO DETERMINE SPREADER SETTINGS AND SPREAD WIDTH" for details.

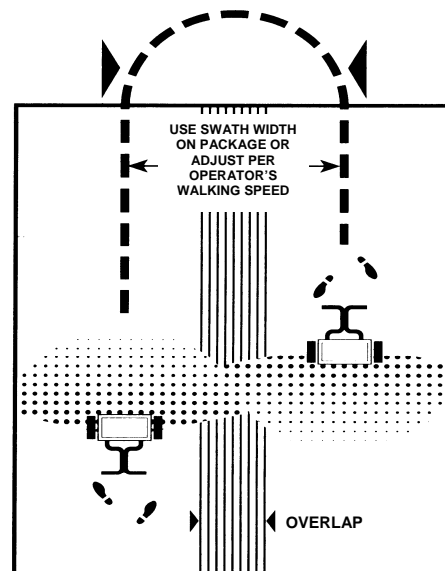

6. Push spreader at a normal walking speed - 2 1/2 m.p.h. (18 feet in 5 seconds). Apply header strips around area to be treated. Space trips across the area as shown. Keep material off flower beds, sidewalks, etc.

7. When transporting spreader, make sure that it is in the "OFF" position.

8. Empty spreader after each use. Return leftover material to its original container.

PATTERN ADJUSTMENT

Normal spreading of materials requires no adjustment (factory setting "A") unless stated on the package. In those cases where the spread pattern has shifted, the pattern can be adjusted left and right by loosening the two knobs on the discharge chute and moving the chute closer or farther away from the impeller. Settings of "A, B, and C" are provided as reference.

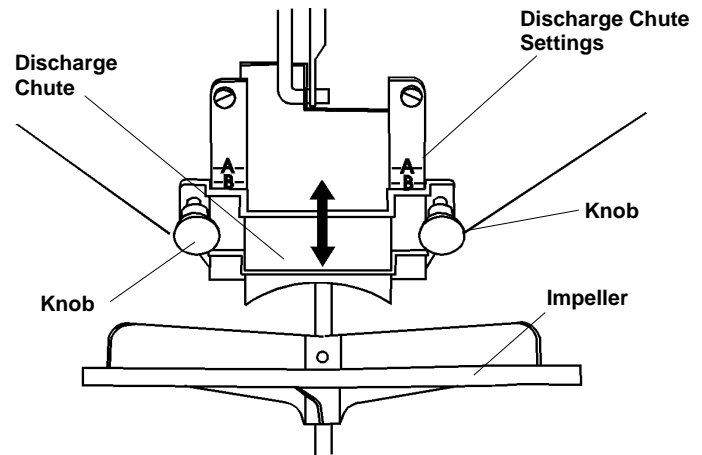

HOW TO DETERMINE SPREADER SETTINGS AND SPREAD WIDTH

Two major factors should be considered when determining correct spreader settings of any product:

1. The product application rate, or the amount of material applied per 1,000 square feet.

2. The effective pattern width, or the actual width in which material is applied. Label settings are a guide and can be affected by numerous factors.

EFFECTIVE PATTERN WIDTH

A simple visual pattern test can be made by operating the spreader over a non-turf area and evaluating the pattern. A more accurate method is to place a row of common, disposable, aluminum cake pans approximately 1 foot on centers. Set the rate plate at a middle setting and make 3 or 4 passes in the same direction as shown. Pour the material collected from each pan into individual bottles of the same size. Set them side by side in order, and visually inspect their volume. If the pattern is not centered (example: volume in bottle #2 left not equal to bottle #2 right), adjust the discharge chute up or down as described in "PATTERN ADJUSTMENT" section.

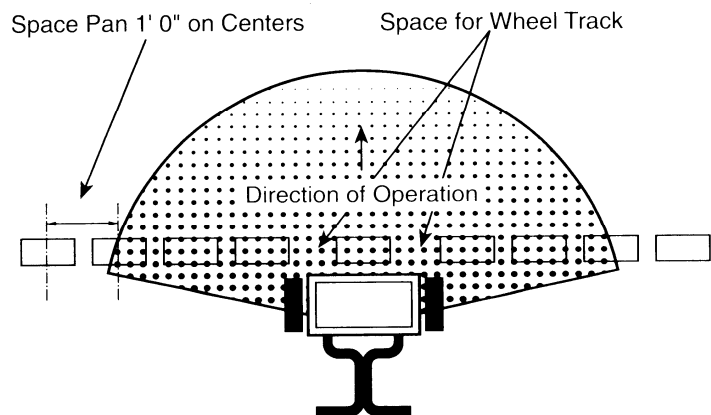

Once the pattern is uniform, the effective pattern width can be determined. The effective pattern width is the distance out from the spreader to a point where the amount of material is 1/2 the average amount in the center pans. This distance is multiplied by 2 to achieve the total effective pattern width.

APPLICATION RATE

Knowing the effective pattern width (for example, 10 feet), measure a distance equal to 100 square feet (10' x 10' swath width). Determine the product coverage in pounds / 100 sq. ft. by taking the weight of the product and dividing it by the recommended square foot coverage (add two zeroes to the weight of the bag).

EXAMPLE: Product weight: 25 lbs.
sq. ft. coverage: 5,000 sq. ft.
2500 lbs. - 5,000 sq. ft.
= .5 lbs. / 100 sq. ft.





Weigh out 15 to 20 lbs. of material and spread over the 100 sq. ft. area. Weigh remaining material left in hopper and adjust rate setting as required. Repeat test until application rate is correct.

RATE SETTING CONVERSION

The following provides approximate **Meyer HOTSHOT HD** settings for those units listed.

Meyer HOTSHOT HD Setting	B	C	D	E	F	G	H	I	J	K	L	M	N	O	P	Q	R	S	T	U	V	W	X	Y	Z
Prizelawn. BF I / CBR III Setting	B	C	D	E	F	G	H	I	J	K	L	M	N	O	P	Q	R	S	T	U	V	W	X	Y	Z
Prizelawn. CBR II Setting	—	2	—	2.5	—	3	3.5	—	4	—	4.5	5	5.5	6	6.5	7	8	9.5	10	11	12	13	14	15	—
Lesco #029600 Setting	—	B	C	D	—	E	F	—	G	H	I	—	J	K	L	—	M	N	O	—	P	Q	R	—	S
Scotts R8A/SR-1 Setting	D	E	F	G	H	I	J	K	L	M	N	O	P	Q	R	S	T	U	—	V	W	—	X	Y	Z
Earthway 2200/2400 Setting	5	—	—	—	10	—	—	—	—	15	—	—	—	—	20	—	—	—	—	25	—	—	—	—	30
Spyker 76/78-2 Setting	—	3	—	—	—	4	—	—	5	—	—	6	—	—	7	—	—	8	—	—	—	9	—	—	10
Scotts SPEEDY GREEN	—	—	—	2	—	—	3	3.5	J	4.5	5	5.5	6	—	6.5	—	7	—	7.5	—	8	—	8.5	—	9

The following provides approximate **Meyer HOTSHOT HD** settings when only the product weight, square foot coverage, and visual inspection of the material is available.

FERTILIZER PARTICLE SIZE	BAG RATE Pounds of fertilizer used per 1,000 sq. ft. of coverage	APPROX. SETTING	SPREAD WIDTH (IN FEET)
Large, heavy particles 	5	M	8
	10	O	8
	15	Q	8
Medium- mixed particles 	5	L	8
	10	N	8
	15	O	8
Small particles (nitrogen) 	1	G	8
	2	J	8
	3	L	8
Mixed size particles -some fines 	5	M	6
	10	O	6
	15	P	6
Light weight particles 	5	J	4
	10	L	To
	15	O	6

The conversions should be used as guidelines for establishing proper rate settings for the particular product being applied. Steps for obtaining the most accurate settings are outlined in the "How to Determine Spreader Settings and Spread Width" section of this manual. These settings are approximate and may vary due to physical characteristics of the product. Walking speed, wear, condition of the turf and humidity, may cause actual rate setting to deviate. No expressed nor implied warranty or guarantee is provided as to coverage or uniformity indicated by these rate settings.

MAINTENANCE

1. Never store unused material in spreader. Return unused product to its original container.
2. Wash spreader thoroughly after each use and dry completely in sun or heated area.
3. Grease axle bearings in frame. Oil the impeller shaft bearing in hopper, pivot points on the shut-off plate and the spring in the housing behind the rate plate.
4. Remove gear cover and wash gears thoroughly. Oil all bearing areas and face of gear teeth. Lubricate gear teeth with dry graphite. Re-install gear cover.
5. Gear mesh should be checked on a regular basis during high use periods. Clearance between the axle gear and pinion gear should be minimal but not tight. If adjustment is necessary, loosen axle collar set screw and hold gears together. Slide axle collar against the gear support and tighten axle collar set screw. Spin drive wheel. Gears should run freely and smoothly.
6. Impeller surface should be cleaned periodically to remove build-up of product. Build-up can cause the spread pattern to change.
7. Tire pressure should be 20-25 PSI.

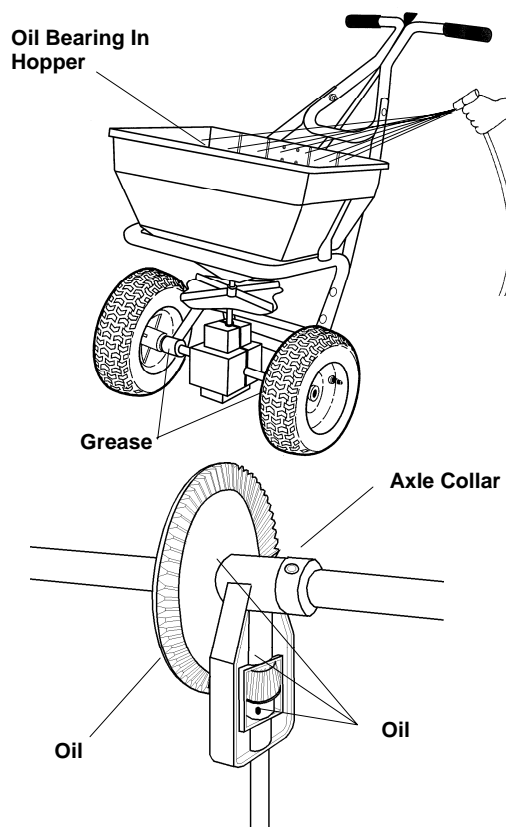

CALIBRATION INSTRUCTIONS

The **Meyer HOTSHOT HD** was factory calibrated, however, calibration should be checked occasionally to assure optimum performance.

1. Pull the on/off lever to the "OFF" position. Set the rate control plate to setting "B".

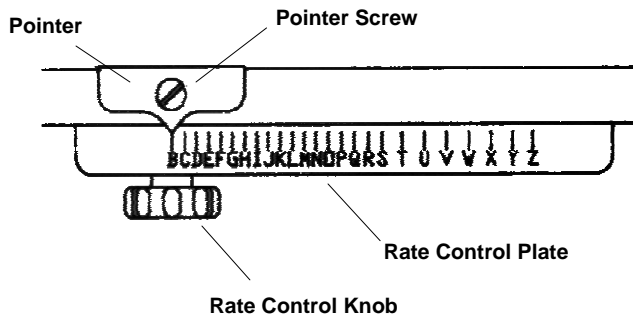

2. Flip on/off control lever to the "ON" position. Check the port opening. It should be just open. If adjustment is necessary, continue to step #3.

3. Loosen the rate control knob and slide the rate plate until the port is just opening. Loosen pointer screw and move pointer until it aligns with "A" on the rate plate. Retighten pointer screw.

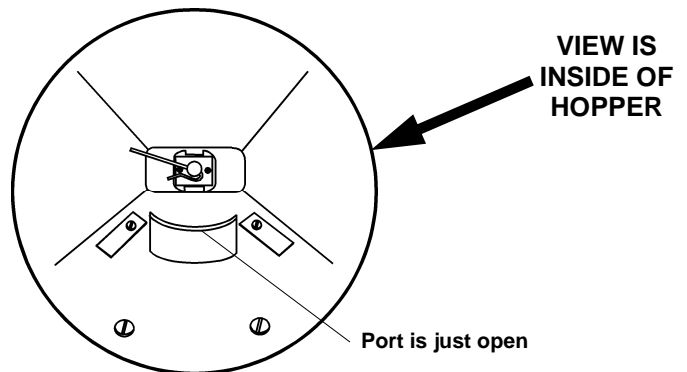

WARRANTY

Meyer Products warrants to Purchaser the following:

Meyer Products, Inc., warrants to the original purchaser for a period of one year from the date of purchase of Meyer® and Diamond® brand spreader products that they will be free from defects in materials or workmanship, with the exceptions stated below. No person is authorized to change this warranty or to create any additional warranty on Meyer®/Diamond® products.

Meyer Products will repair any product that proves to be defective in materials or workmanship. In the event repair is not possible or practical (as determined by Meyer Products in its sole discretion), Meyer Products will either replace the product with a new product of similar model and price, or refund the full purchase price, as determined by Meyer Products. Customer must keep the complete spreader system serviced/maintained as recommended by Meyer Products.

This warranty does not cover:

- Problems caused by failure to follow the product instructions, or failure to maintain the product as described in the Operator's Manual;
- Damage resulting from rust, corrosion
- Damage caused by usage that is not in accordance with product instructions (use of the spreader for any purpose other than spreading approved material is considered misuse and abuse);
- Any spreader, or any part, component, or assembly thereof, which has been modified or altered;
- Problems caused by using accessories, parts, or components not supplied by Meyer Products;
- Cost of tax, freight, transportation or storage charges, environmental charges, solvents, sealants, lubricants or any other normal shop supplies.
- Problems caused by collision, fire, theft, vandalism, riot, explosion, lightning, earthquake, windstorm, hail, water, flood, or any other Acts of God;
- Liability for damage to property, or injury to, or death of any person arising out of the operation, maintenance or use of the covered product;
- Products with missing or altered serial numbers;

How To Get Service:

• It is the responsibility of the original purchaser to establish the warranty period by verifying the original delivery date. A bill of sale, cancelled check or some other appropriate payment record may be kept for that purpose. It is recommended, but not required, that the consumer verify the original delivery date by immediately returning the attached Warranty Registration Card.

How State Law Applies:

This warranty gives you specific legal rights, and you may also have other rights which vary from state to state.

Parts List For Model 38140

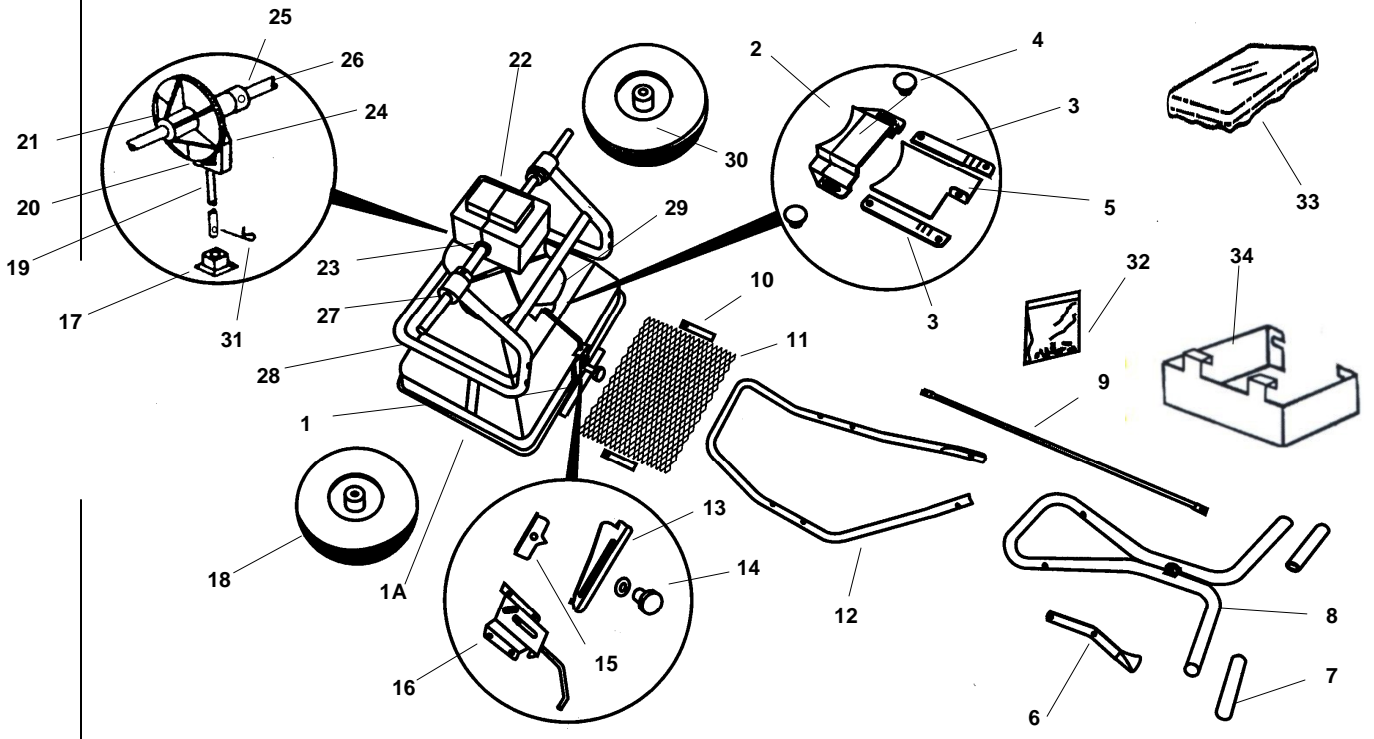

PART OF OUR SERVICE IS PROVIDING REPLACEMENT PARTS. Parts may be obtained through your local distributor. Be sure to give:

1. SPREADER MODEL NUMBER
2. SPREADER NAME
3. PART NUMBER
4. NAME OF PART AS SHOWN



IF YOUR LOCAL DISTRIBUTOR CANNOT SUPPLY PARTS, CONTACT:

Meyer Products, Inc.

18513 Euclid Ave

Cleveland, Ohio 44112

216-486-1313 www.meyerproducts.com

No.	Description	Part No.	No.	Description	Part No.
1	Hopper Assembly	PSB15474	18	Drive Wheel	PSB15950
1A	Hopper*	PSB15476	19	Impeller Shaft	PSB15641
2	Discharge Chute	PSB15477	20	Pinion Gear	PSB 14833
3	Plate Guides *	PSB15478	21	Axle Gear	PSB14832
4	Discharge Chute Knob (2)	PSB14001	22	Gear Cover (2)	PSB15753
5	Shutoff Plate*	PSB13353	23	Gear Cover Clamps (3)	PSB14868-1
6	Handle Lever Ass'y	PSB15513	24	Gear Support	PSB 14834
7	Handle Grip (2)	PSB 14870	25	Axle Collar w/ Set Scr.	PSB14971-1
8	Upper Handle	PSB 15498	26	Axle	PSB15518
9	Control Tube	PSB14916	27	Axle Bearing (4)	PSB14855
10	Screen Clips (2)	PSB14022	28	Frame Assembly	PSB15502
11	Hopper Screen	PSB14603	29	Impeller	PSB15459
12	Handle Brace/Leg	PSB 15508	30	Free Wheel	PSB15951
13	Rate Plate*	PSB15481	31	Agitator	PSB14510
14	Rate Control Knob*	PSB12704	32	Fastener Package	PSB15977
15	Pointer*	PSB12708	33	Hopper Cover	PSB14606-1
16	Spring Housing Assembly*	PSB15527	34	Deflector Shield	PSB15972
17	Impeller Shaft Bearing*	PSB14312-1			

*Parts included in hopper assembly