

Operation

1 Operating the impact wrench

- This 1/2 in. Impact Wrench is designed to operate on 90 PSIG. Lower pressure (below 90 PSIG) will reduce performance of the tool. Higher air pressure (over 90 PSIG) raises the performance of the tool beyond its rated capacity and could cause serious damage to the tool and the user.

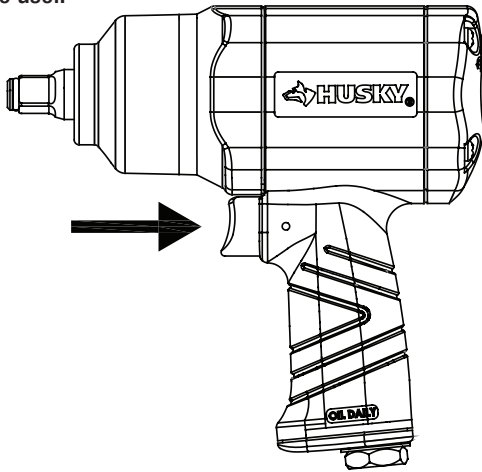

2 Changing the output torque direction

- This tool features the reverse switch to change the output torque direction to tighten (assemble) or loosen (disassemble) the bolt or fastener.
- Control the output torque direction by turning the reverse switch button to the Forward arrow or Reverse arrow position to change the direction.

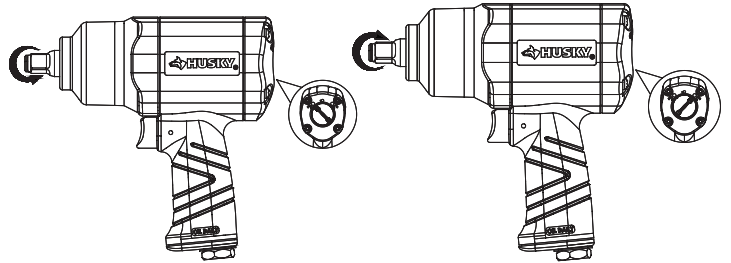

3 Changing the output torque level

- This tool features the air regulator to manage the output power located on the back of the housing.
- Turn the knob to adjust to your desired torque level.
- The left setting is the lowest power level, the center setting is a medium power level, and the right setting is the highest power level.

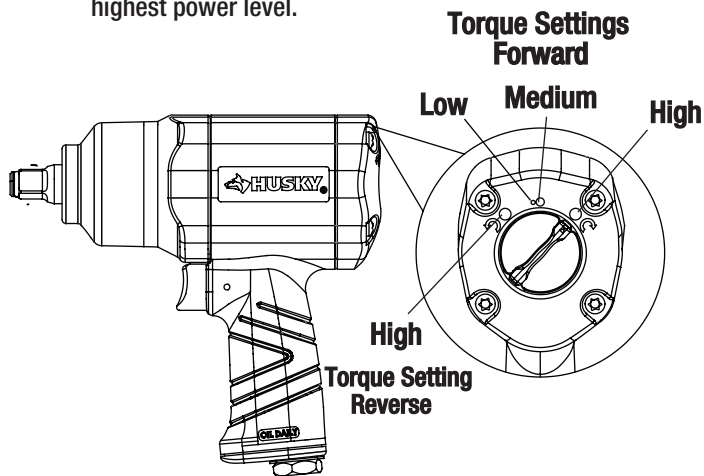

4 Installing and removing the impact sockets



WARNING: Disconnect the tool from the air supply before servicing or changing accessories. Always use sockets rated for impact wrenches.

To install the impact socket:

- Disconnect the tool from the air source.
- Select the suitable and desirable socket size.
- Press fit the anvil into the socket.

To remove the impact socket:

- Disconnect the tool from the air source.
- Use your hand or a suitable tool to remove the socket.

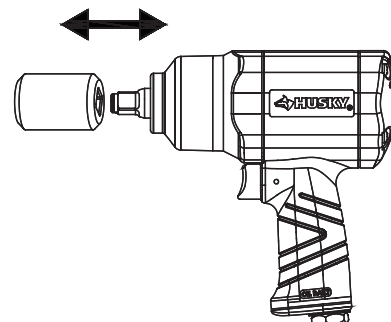

Operation (continued)

5 Tightening or loosening the bolt or fastener



WARNING: Once a bolt or fastener is seated, impacting for longer than five (5) seconds will cause excessive wear and possible damage to the impact mechanism. If it takes longer to tighten or loosen your bolt or fastener, we recommend the use of a larger sized impact wrench.

- Fit the impact socket.
- Hold the impact wrench with one hand.
- Ensure that the operator is aware of the torque direction to tighten (Forward) or loosen (Reverse) and has selected the suitable torque level.
- Use the tool to tighten or loosen the bolt or fastener.

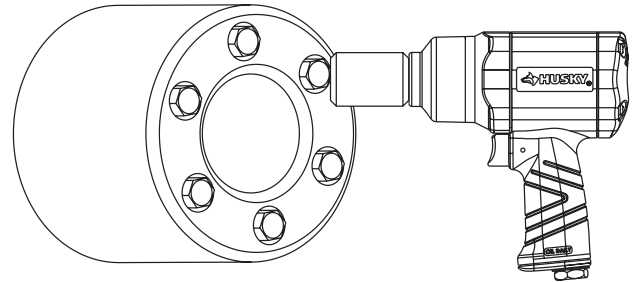

Maintenance

Ensure the air line is shut-off and drained of air before removing this tool for service or changing sockets. This will prevent the tool from operating if the throttle is accidentally engaged.

LUBRICATION

- An in-line filter-regulator-lubricator is recommended as it increases tool life and keeps the tool in sustained operation.
- Regularly check and fill the in-line lubricator with air tool oil. Avoid using excessive amounts of oil.
- Adjust the in-line lubricator by placing a sheet of paper next to the tool's exhaust ports and holding the throttle open approximately 30 seconds. The lubricator is properly set when a light stain of oil collects on the paper.
- If it is necessary to store the tool for an extended period of time (overnight, weekend, etc.), generously lubricate the tool through the air inlet. Run the tool for approximately 30 seconds to ensure the oil is evenly distributed throughout the tool. Store the tool in a clean and dry environment.
- Recommended lubricants: Air tool oil or any other high grade turbine oil containing moisture absorbent, rust inhibitors, metal wetting agents, and an EP (extreme pressure) additive.

