

COMPONENT VIEW AND REFERENCE LIST

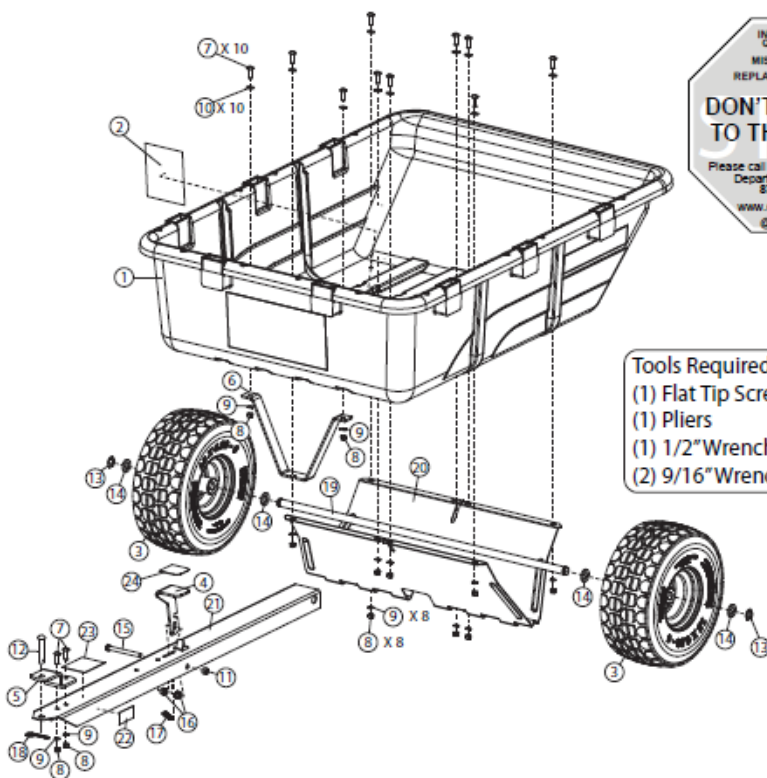

INSTALLATION
QUESTIONS?
MISSING PARTS?
REPLACEMENT PARTS?
**DON'T GO BACK
TO THE STORE!**
Please call our Customer Service
Department Toll-Free at
877.728.8224
or
www.customerservice
@brinly.com

Tools Required:
(1) Flat Tip Screw Driver
(1) Pliers
(1) 1/2" Wrench
(2) 9/16" Wrenches

REF	PART NO.	DESCRIPTION	QTY	REF	PART NO.	DESCRIPTION	QTY
1	1008574	Poly Bed	1	13	B-4305	"E" Ring, 3/4"	2
2	B-7084	Warning Label	1	14	B-5606	Machine Bushing	4
3	1008575	Wheel	2	15	B-6298	Hex Hd Bolt, 3/8" X 3-3/4"	1
4	1008604	Foot Pedal	1	16	B-6299	Keys Hex Nut, 3/8"	2
5	B-3034-10	Clevis	1	17	B-6300	Latch Spring	1
6	B-3520-10	Lock Bracket	1	18	D-148P	Hairpin Cotter, 1/8"	1
7	20M1016P	Rd. Hd. Screw, 5/16" X 1"	12	19	B-4261	Axle, 3/4" X 34-3/4"	1
8	30M1000P	Hex Nut, 5/16"	12	20	B-4599-10	Axle Support	1
9	40M1000P	Lock Washer, 5/16"	12	21	B-6296-2	Towbar	1
10	45M1111P	Flat Washer, 5/16"	10	22	L-1744	Serial Number Label	1
11	B-1675P	Hex Lock Nut, 3/8"	1	23	B-5482	Caution Decal	1
12	B-3861	Hitch Pin, 1/2" X 2-1/2"	1	24	1008603	Grip Tape	1