



**HORIZONTAL / VERTICAL  
22 / 25 / 28 / 30 / 35 TON  
GAS LOG SPLITTER**



**MODEL NO.  
WD22T / 25T / 28T / 30T / 35T  
Owner's Manual**

**ASSEMBLY & OPERATING INSTRUCTIONS**

Purchase Date \_\_\_\_\_ Model NO. \_\_\_\_\_ Serial NO. \_\_\_\_\_  
Dealer \_\_\_\_\_

**Boss Industrial, Inc.** · 5 Earl Court, Unit 120 · Woodridge, IL 60517 · USA  
Phone: (800) 780-BOSS (2677) · Fax (331) 472-2976

## To The Owner

Thank You!

Thank you for purchasing a BOSS Log Splitter. It was carefully engineered to provide excellent performance when properly operated and maintained.

Please read this entire manual prior to operating the equipment. It instructs you how to safely and easily set up, operate and maintain your machine. Please be sure that you, and any other persons who will operate the machine, carefully follow the recommended safety practices at all times. Failure to do so could result in personal injury or property damage.

All information in this manual is relative to the most recent product information available at the time of printing. Review this manual frequently to familiarize yourself with the machine, its features and operation. Please be aware that this Operator's Manual may cover a range of product specifications for various models. Characteristics and features discussed and/or illustrated in this manual may not be applicable to all models. We reserve the right to change product specifications, designs and equipment without notice and without incurring obligation.

All the power testing information used to establish the power rating of the engine equipped on this machine can be found at the engine manufacturer's manual or website. If you have any problems or questions concerning the machine, phone an authorized service dealer or contact us directly. Boss Industrial's customer support phone number, website and mailing address can be found on this page. We want to ensure your complete satisfaction at all times.

Throughout this manual, all references to right and left side of the machine are observed from the operating position. The engine manufacturer is responsible for all engine-related issues with regards to performance, power-rating, specifications, warranty and service. Please refer to the engine manufacturer's Owner's/Operator's Manual packed separately with your machine for more information.

## Customer Support

***Please do NOT return the machine to the retailer or dealer without first contacting the Customer Support Department.***

If you have difficulty assembling this product or have any questions regarding the controls, operation, or maintenance of this machine, you can seek help from the experts. Choose from the options below:

- ◇ Visit us on the web at [www.boss-industrial.com](http://www.boss-industrial.com)
- ◇ Call a Customer Support Representative at (800) 780-2677 or (331) 457-5670
- ◇ Write to Boss Industrial, Inc., 5 Earl Court, Unit 120, Woodridge, IL 60517

# Table of Contents

	Page(s)
Important Safety Information.....	1-10
General Safety Alert Signals .....	1
Safety Decals .....	2
Safety Symbols .....	3
Training .....	4
Pre-operation .....	5
Operation .....	6
Operator Zone.....	7
Maintenance Safety.....	8
Fire Prevention .....	9
Towing Safety .....	10
Assembly & Set-up Instructions .....	11-22
Unpacking the Container.....	11-12
Assembling .....	13-19
Set-up .....	20-21
Know Controls & Features.....	22
Operating Instructions .....	23-26
Starting & Stopping the Engine.....	23
Operating Positions .....	23
Using Control Handle.....	24
Splitting the Wood .....	25
Transporting the Log Splitter .....	26
Maintenance & Adjustments.....	27-28
Troubleshooting.....	29
Specifications .....	30
Exploded Diagram & Parts List .....	31-34
Packing List.....	35
Warranty Service Information.....	36



# IMPORTANT SAFETY INFORMATION



***WARNING:*** Read and thoroughly understand all instructions in this manual and on safety decals before assembling or operating this log splitter. Failure to do so may cause serious injury or death. Do not allow anyone to operate this log splitter who has not read this manual. As with all power equipment, a log splitter can be dangerous if assembled or used improperly. Do not operate this log splitter if you have any questions concerning safe operation. To get answers to any questions, call our customer service department at 1-800-780-2677.

*Si no entiende ingles, se prefiere que busque alguien que interprete las instrucciones para usted.*



*This SAFETY ALERT SYMBOL identifies important safety messages in this manual. Failure to follow this important safety information may result in serious injury or death.*

## CALIFORNIA PROPOSITION 65



**WARNING!** Engine Exhaust, some of its constituents, and certain vehicle components contain or emit chemicals known to State of California to cause cancer and birth defects or other reproductive harm.



**DANGER!** This machine was built to be operated according to the safe operation practices in this manual. As with any type of power equipment, carelessness or error on the part of the operator can result in serious injury. This machine is capable of amputating hands and feet and throwing debris. Failure to observe the following safety instructions could result in serious injury or death.

The following signal words and meanings are intended to explain the levels of risk associated with this product.



**DANGER**

**DANGER** indicates a hazardous situation which, if not followed, will result in serious injury or death.



**WARNING**

**WARNING** indicates a hazardous situation which, if not avoided, could result in serious injury or death.



**CAUTION**

**CAUTION** indicates a hazardous situation which, if not avoided, could result in minor or moderate injury.

**NOTICE**

**NOTICE** is important information about the proper use of your machine. Failure to follow this instruction could result in damage to your machine or property.



# IMPORTANT SAFETY INFORMATION

## SAFETY DECALS

Make sure that all safety warning decals are in good condition and readable. Always replace missing or defaced decals. Contact BOSS at 1-800-780-2677 for replacement decals.

OPERATING INSTRUCTIONS		CAUTION!	WARNING!	WARNING!	WARNING!
<p><b>3 POSITIONS OF CONTROL HANDLE</b></p> <p><b>FORWARD NEUTRAL REVERSE</b></p> <ul style="list-style-type: none"> <li>Place log splitter on flat dry solid ground and block wheels.</li> <li>Lock the beam in either the Horizontal or Vertical position.</li> <li>Start the engine as instructed in the Engine Operator's manual included.</li> <li>Grab the sides of the log to load the log onto the beam against the end plate.</li> <li>If necessary, stabilize the log with your left hand on its sides, NEVER on the ends or the top.</li> <li>Move the control handle to the FORWARD position with your right hand to split the log. Remove your left hand when the wedge just contacts the log.</li> <li>Release the control handle to stop the wedge movement.</li> <li>Move the control handle to the REVERSE position to return the wedge and dislodge the log.</li> </ul>		<p><b>CAUTION!</b></p> <ul style="list-style-type: none"> <li>Read and understand safety and operating instructions in owner's manual completely. Failure to do so may result in serious injury or death.</li> <li>Always wear safety glasses, safety shoes, protective hearing devices, and tight fitting gloves during operation.</li> <li>Set up log splitter on clear, level, dry and solid ground. Keep off slopes and slippery surfaces. Always block the wheels.</li> <li>Do not leave the engine running unattended.</li> <li>Only split wood in the direction of the grain.</li> </ul>	<p><b>WARNING!</b></p> <ul style="list-style-type: none"> <li>No one under the age of 18 should operate log splitter.</li> <li>Only one person is permitted to load logs and operate controls. Keep bystanders, children, pets and helpers at least 25 ft. away.</li> <li>Always stay in operator zone specified by manufacturer during operation.</li> <li>Keep work area clear of split wood, debris, and other obstacles.</li> <li>Do not operate log splitter under the influence of alcohol or drugs.</li> <li>Do not stand on or reach over log splitter.</li> </ul>	<p><b>WARNING!</b></p> <ul style="list-style-type: none"> <li>Keep hands, feet and all body parts away from splitting wedge, end plate, partially split wood, and moving parts.</li> <li>Never check for leaks with your hands during operation. High pressure fluid can escape from small holes and cause serious injury by puncturing skin which could result in blood poisoning.</li> <li>NEVER use your hands to dislodge a log from the wedge. This log splitter is equipped with log dislodge, lodged log will be removed automatically when wedge is fully retracted.</li> </ul>	<p><b>WARNING!</b></p> <ul style="list-style-type: none"> <li>Do not refill hydraulic oil while engine is hot or running.</li> <li>Do not refuel a hot or running engine. Allow the engine to cool at least 10 minutes before refueling.</li> <li>Never run an engine indoors or in a poorly ventilated area. Engine exhaust contains carbon monoxide, an odorless and deadly gas.</li> <li>Engine parts, especially the muffler, become extremely hot during operation. Do not touch.</li> </ul> <p>Part #: 410-188</p>

Part #: 410-188

**WARNING!**

To minimize risk of serious injury or death to you or others, when towing this log splitter:

- Read instruction manual for how to properly attach coupler to hitch ball and how to tow safely.
- Never attempt to move this machine over uneven or hilly terrain without a tow vehicle or adequate help.
- Use the ball of correct size.
- Do not exceed weight capacity of ball or load limits of coupler.
- Always use safety chains.
- Never exceed 45 mph.
- Avoid sharp turns and steep angles.
- Make sure of the coupler tightness each time before towing and after towing 50 miles.
- Replace damaged ball or coupler immediately.

Part #: 410-249

Part #: 410-249

**DANGER!**

- Do not use your hands to dislodge log from wedge.
- Keep hands away from wedge, end plate, partially split wood and moving parts.
- If wedge moves FORWARD when control handle released, STOP USE IMMEDIATELY! Valve may be damaged.

**DANGER**

KEEP HANDS AND FEET AWAY!

Part #: 410-237

Part #: 410-237

**KEEP HANDS / FEET AWAY!**

- Do not use your hands to dislodge log from wedge.
- Keep hands away from wedge, end plate, partially split wood and moving parts.
- If wedge moves FORWARD when control handle released, STOP USE IMMEDIATELY! Valve may be damaged.

**DANGER!**

Part #: 410-233

Part #: 410-233

**NOTICE**

- Maintain oil level within the range specified on dipstick. Check before each use when oil is cold. DO NOT OVERFILL! Never run the log splitter without sufficient oil. The hydraulic pump could be ruined.
- Change hydraulic oil every 100 hours of use. AW32 universal Hydraulic oil is recommended. Dextron II transmission fluid can be used as a substitute should AW32 oil not be available. Do NOT mix AW32 hydraulic oil with Dextron II transmission fluid. Drain the reservoir if you wish to use Dextron II.
- Use only the filter of original equipment manufacturer's (O.E.M.).

Part #: 410-647

Part #: 410-647



# IMPORTANT SAFETY INFORMATION

## SAFETY SYMBOLS

This page depicts and describes safety symbols that may appear on this product. Read, understand, and follow all instructions on the machine before attempting to assemble and operate.

Symbol	Description
	<b>READ THE OPERATOR'S MANUAL(S)</b> Read, understand, and follow all instructions in the manual(s) before attempting to assemble and operate.
	<b>FACE PROTECTION</b> Always wear safety goggles or safety glasses with side shields, or a face shield when operating this product as well as ear protection.
	<b>WARNING— MOVING WEDGE</b> Keep hands away from wedge, moving part, end plate, and partially split wood.
	<b>BYSTANDERS</b> Keep bystanders, helpers and children at least 25 feet away.
	<b>SINGLE OPERATOR</b> Only one person should operate the machine at a time. The adult who loads and stabilizes the log must be the person who operates control handle.
	<b>WARNING— PRESSURIZED FLUID</b> Never check for hose leaks with your hands. High pressure fluid can escape through a pin hole leak and cause serious injury by puncturing the skin and causing blood poisoning.
	<b>WEAR GLOVES</b> Always wear nonslip, heavy-duty protective gloves when operating this product.
	<b>WEAR SAFETY FOOTWEAR</b> Always wear nonslip steel-toed safety footwear when operating this product.
	<b>WARNING—GASOLINE IS FLAMMABLE</b> Allow the engine to cool at least ten minutes before refueling.
	<b>WARNING— CARBON MONOXIDE</b> Never run an engine indoors or in a poorly ventilated area. Engine exhaust contains carbon monoxide, an odorless and deadly gas.
	<b>WARNING— HOT SURFACE</b> Engine parts, especially the muffler, become extremely hot during operation. Allow engine and muffler to cool before touching.



**WARNING!** Your Responsibility—Restrict the use of this power machine to persons who read, understand and follow the warnings and instructions in this manual and on the machine.

**SAVE THESE INSTRUCTIONS!**



# IMPORTANT SAFETY INFORMATION

## TRAINING

1. Read, understand, and follow all instructions on the machine and in the manual(s) before attempting to assemble and operate. Keep this manual in a safe place for future and regular reference and for ordering replacement parts.
2. Be familiar with all controls and their proper operation. Know how to stop the machine and disengage them quickly.
3. Never allow children under 18 years of age to operate this machine. Children 16 and over should read and understand the instructions and safe operation practices in this manual and on the machine and be trained and supervised by an adult.
4. Never allow adults to operate this machine without proper instruction.
5. Many accidents occur when more than one person operates the machine. No helper is allowed to assist in stacking logs.
6. Keep bystanders, pets, and children at least 25 feet from the machine while it is in operation.
7. Never allow anyone to ride on this machine.
8. Never transport cargo on this machine.
9. Hydraulic log splitters develop high fluid pressures during operation. Fluid escaping through a pin hole opening can penetrate your skin and cause blood poisoning, gangrene, or death. Give attention to the following instructions at all times:
  - a. Do not check for leaks with your hand.
  - b. Do not operate machine with frayed, kinked, cracked, or damaged hoses, fittings, or tubing.
  - c. Stop the engine and relieve hydraulic system pressure by cycling the valve control lever from forward to reverse several times while engine is not running. Return to neutral before repairing or adjusting fittings, hoses, tubing, or other system components.
  - d. Do not adjust the pressure settings of the pump or valve.
10. Leaks can be detected by passing cardboard or wood over the suspected areas. Always wear protective gloves and safety glasses when checking. Look for discoloration of cardboard or wood.
11. If injured by escaping fluid, see a doctor immediately. Serious infection or reaction can develop if proper medical treatment is not administered immediately.
12. Keep the operator zone and adjacent area clear for safe, secure footing.
13. If your machine is equipped with an internal combustion engine and is intended for use near any unimproved forest, brush, or grass covered land, the engine exhaust should be equipped with a spark arrestor. Make sure you comply with applicable local, state, and federal codes. Take appropriate firefighting equipment with you.



**NEVER** use this log splitter for any purpose other than splitting wood. It is designed for this use only. Any other use can cause serious injury or death.



# IMPORTANT SAFETY INFORMATION

## PRE-OPERATION

1. **BEFORE** operating this log splitter, make sure that you wear safety gear such as goggles or safety glasses, steel toed shoes and tight fitting gloves (without loose cuffs or draw strings). Always wear a protective hearing device when operating this log splitter.
2. **NEVER** wear loose clothing or jewelry that can be caught by moving parts of the log splitter. Keep clothing and hair away from all moving parts when operating this log splitter.
3. Check all safety guards and shields to be sure they are in the proper position. Never operate with safety guards, shields, or other protective features removed.
4. Make sure machine is on a flat, dry, solid ground before operating.
5. **ALWAYS** operate your log splitter in an open area. (Exhaust fumes contain carbon monoxide which can be deadly when inhaled.)
6. **ALWAYS** operate your log splitter in daylight or under good artificial light.
7. **ALWAYS** operate your log splitter on level ground. (Operating on a slope could cause the log splitter to roll over or logs to fall off.)
8. **ALWAYS** block wheels to prevent unintended movement.
9. **ALWAYS** lock beam in either the horizontal or vertical position.
10. **ALWAYS** keep the work area clean. Remove split wood from around the log splitter immediately so that you don't stumble over it.
11. Check all nuts, bolts and hydraulic fittings are tight to be sure the equipment is in a safe working condition.
12. Both ends of the log should be cut as square as possible to help prevent the log from riding out of the splitter during operation. Do not split logs greater than 25 inches in length. Uneven logs (e.g. knotted, curved, etc.) should not be used.
13. **ALWAYS** check the oil level before you start the log splitter. **See Page 27.**
14. Do not allow familiarity with tools to make you careless. Remember that a careless fraction of a second is sufficient to inflict serious injury.



### WARNING:



The operation of any power tool can result in foreign objects being thrown into your eyes, which can result in severe eye damage. Before beginning power tool operation, always wear safety goggles or safety glasses with side shields and, when needed, wear a full face shield and earplugs too. We recommend a Wide Vision Safety Mask for use over eyeglasses or standard safety glasses with side shields. Always use eye protection which is marked to comply with ANSI Z87.1.



# IMPORTANT SAFETY INFORMATION

## OPERATION

1. **BEFORE** starting this machine, review the safety instructions in the manual. Failure to follow these rules may result in serious injury to the operator or bystanders.
2. **NEVER** leave this machine unattended with the engine running.
3. **DO NOT** operate machine while under the influence of alcohol, drugs, or medication.
4. **NEVER** allow anyone to operate this machine without proper instruction.
5. **ALWAYS** operate this machine with all safety equipment in place and working. Make sure all controls are operating properly for safe operation.
6. When loading a log, always place your hands on the side of the log, not on the ends, and never use your foot to help stabilize a log. Failure to do so may result in crushed or amputated fingers, toes, hand, or foot.
7. **NEVER** use your foot, a rope or any extension device to operate the control lever on the valve. Only use hand.
8. Use only your right hand to operate the controls.  
**WARNING!** When stabilizing log with left hand, remove your hand when the wedge begins to contact the log, or serious injury may occur.
9. For logs which are not cut square, the least square end of the log should be placed toward the beam and wedge, and the square end placed toward the end plate.
10. When splitting in the vertical position, stabilize the log before moving the control handle. Split as follows:
  - a. Place log on the end plate and turn until it leans against the beam and is stable.
  - b. When splitting extra-large or uneven logs, the log must be stabilized with wooden shims or split wood placed between the log and end plate or ground.
11. **NEVER** place hands or feet between the log and splitting wedge during forward or reverse stroke as this could result in serious injury or death. **NEVER** attempt to load the log splitter when the ram or wedge is in motion.
12. **ALWAYS** keep fingers away from any cracks that open in the log while splitting. They can quickly close and pinch or amputate your fingers.
13. Keep your work area clean. Immediately remove split wood from around the machine so you do not stumble over it.
14. **NEVER** straddle or step over the log splitter during operation.
15. **NEVER** reach or bend over the log splitter to pick up a log.
16. **NEVER try to split two logs on top of each other. NEVER try to cross split a log.**
17. **NEVER** operate your log splitter when it is in poor mechanical condition or in need of repair.
18. **NEVER** touch the muffler and other hot areas of the engine during operation. Wait until the engine cools down.
19. **NEVER** tamper with the engine to run it at excessive speeds. The maximum engine speed is preset by the manufacturer and is within safety limits. Refer to the engine owner's manual for your particular log splitter.
20. **NEVER** move the log splitter while the engine is running. Shut off the engine if you are leaving the log splitter, even for a short period of time.
21. **ALWAYS** be careful when moving or lifting the log splitter. Get assistance if it feels too heavy to move by yourself.



# IMPORTANT SAFETY INFORMATION

## OPERATOR ZONE

**ONLY** operate the log splitter from the operator zone as shown in the diagrams below. The operator has the safest and most efficient access to the control valve and the beam in this location. Operating the log splitter in another location can result in serious injury or death.

- a. Horizontal Operating Position: Stand on the control lever side of the log splitter and stabilize log if needed. See FIGURE 1.

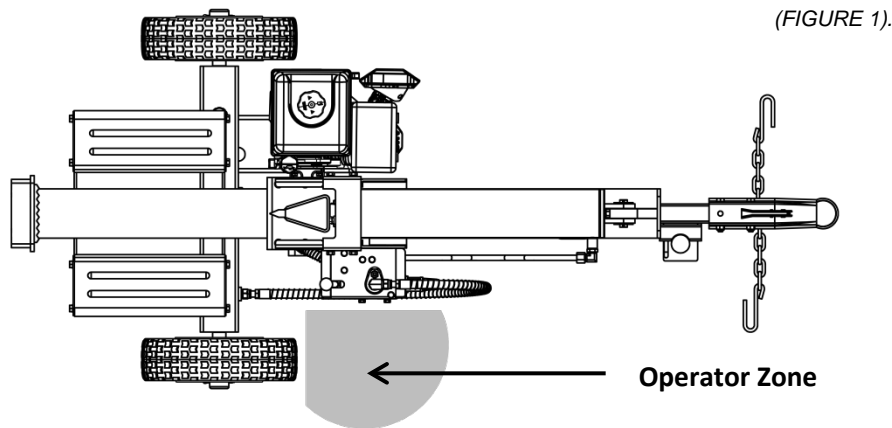

- b. Vertical Operating Position: Stand in front of the log splitter and stabilize log if needed. See FIGURE 2.

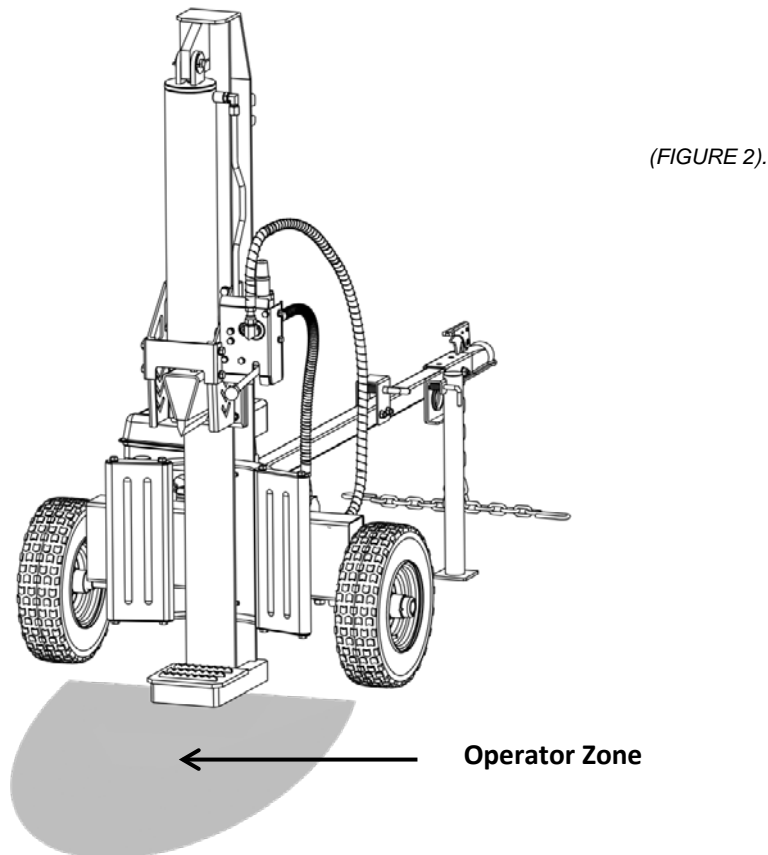



# IMPORTANT SAFETY INFORMATION

## MAINTENANCE SAFETY

1. Stop the engine, disconnect the spark plug and ground it against the engine before cleaning, or inspecting the machine. **NEVER** perform any service or repair on your log splitter without first removing the spark plug wire.
2. Stop the engine and relieve hydraulic system pressure by cycling the valve control lever from forward to reverse several times while engine is not running. Return it to neutral before repairing or adjusting fittings, hoses, tubing, or other system components.
3. **ALWAYS** perform all recommended maintenance procedures before using your log splitter.
4. **ALWAYS** check the level of hydraulic oil and engine oil before operation.
5. **ALWAYS** periodically check that all nuts, bolts, screws, hydraulic fittings and hose clamps are tight to be sure equipment is in safe working condition.
6. **ALWAYS** replace all damaged or worn parts immediately with original equipment manufacturer's (O.E.M.) parts only. Use of parts which do not meet the original equipment specifications may lead to improper performance and compromise safety.
7. The hydraulic system of your log splitter requires careful inspection along with the mechanical parts. Be sure to replace frayed, kinked, cracked or otherwise damaged hydraulic hoses or hydraulic components.
8. **NEVER** check for leaks of hydraulic fluid with your hand. Fluid escaping from a small hole can be almost invisible. Escaping fluid under pressure can have sufficient force to penetrate skin causing **SERIOUS INJURY** or even **DEATH**. Leaks can be safely detected by passing a piece of cardboard over the suspected area and looking for discoloration.
9. **NEVER** remove the cap from the hydraulic tank or reservoir while the log splitter is running. The tank could contain hot oil under pressure which could result in serious injury.
10. **NEVER** adjust the hydraulic valve. The pressure relief valve on your log splitter is preset at the factory. Only a qualified service technician should perform this adjustment.
11. **ALWAYS** seek professional medical attention immediately if injured by escaping hydraulic fluid. Serious infection or reaction can develop if proper medical treatment is not administered immediately.
12. **ALWAYS** be sure to relieve all pressure by shutting off the engine and moving the valve control handle back and forth should it become necessary to loosen or remove any hydraulic fitting.



**NEVER** alter your log splitter in any manner. Such alterations may cause your log splitter to be unsafe and will void the warranty.

According to the Consumer Products Safety Commission (CPSC) and the U.S. Environmental Protection Agency (EPA), this product has an Average Useful Life of seven (7) years, or 130 hours of operation. At the end of the Average Useful Life have the machine inspected annually by an authorized service dealer to ensure that all mechanical and safety systems are working properly and not worn excessively. Failure to do so can result in accidents, injuries or death.



# IMPORTANT SAFETY INFORMATION

## FIRE PREVENTION

1. **ALWAYS** take a Class B fire extinguisher with you when operating this log splitter in dry areas.
2. **NEVER** operate your log splitter near a flame or spark or smoke during operation. Extinguish all cigarettes, cigars, pipes, and other sources of ignition. Hydraulic oil and gasoline are flammable and can explode.
3. To avoid personal injury or property damage use extreme care in handling gasoline. Gasoline is extremely flammable and the vapors are explosive.
4. **ALWAYS** store gasoline in an approved, tightly sealed container and keep away from heating appliances. Store the container in a cool, dry place.
5. When gasoline is spilled on yourself or your clothes, wash your skin and change clothes immediately.
6. **NEVER** refuel the gas tank while the engine is hot or running. Allow the engine to cool before refueling.
7. **ONLY** refuel your log splitter in a clear area with no gas fumes or spilled gas. Never fuel the machine indoors.
8. Never overfill the fuel tank. Fill tank to no more than 1/2 inch below bottom of filler neck to provide space for fuel expansion.
9. If gasoline is spilled out, wipe it off the engine and equipment, and move machine to another area. Wait five (5) minutes before starting the engine.
10. **ALWAYS** replace the gas cap securely. Never remove gas cap while the engine is hot or running.
11. To prevent fires, clean debris and chaff from the engine and muffler areas.
12. Allow machine to cool at least ten (10) minutes before storing.
13. **ALWAYS** drain the fuel tank prior to storage to avoid the potential fire hazard.
14. Never store the machine or fuel container inside where there is an open flame, spark or pilot light as on a water heater, space heater, furnace, clothes dryer or other gas appliances.
15. If the engine is equipped with a spark arrestor muffler, clean and inspect it regularly according to manufacturer's instructions. Replace if damaged.

### SPARK ARRESTOR



#### WARNING!

This log splitter is equipped with an internal combustion engine and should not be used on or near any unimproved forest-covered, brush-covered or grass-covered land unless the engine's exhaust system is equipped with a spark arrester meeting applicable local or state laws (if any). If a spark arrester is used, it should be maintained in effective working order by the operator. In the state of California, a spark arrester is required by law. Other states may have similar restrictions. Always follow Federal laws that apply on federal lands. A spark arrester muffler is optional and available as an accessory at your nearest engine dealer. Always check the legal requirements in your area.



# IMPORTANT SAFETY INFORMATION

## TOWING SAFETY

1. **NEVER** carry any cargo or wood on your log splitter.
2. **NEVER** allow anyone to sit or ride on your log splitter.
3. **ALWAYS** turn the fuel shut off valve on the engine to the “OFF” position before towing the log splitter. Failure to do so may result in flooding the engine.
4. **ALWAYS** check to make sure the low coupler is adjusted properly each time before towing and after towing 50 miles.
5. **ALWAYS** check before towing to make sure that the log splitter is correctly and securely attached to the towing vehicle and that the safety chains are secured to the hitch or bumper of the vehicle with enough slack to allow turning. Always use a Class I, 2” ball with this log splitter.
6. **NEVER** exceed weight capacity of ball or load limits of coupler. **ALWAYS** replace ball or coupler if damaged.
7. **NEVER exceed 45 mph when towing your log splitter.** Towing the log splitter at speeds higher than 45 mph could result in loss of control, damage to the equipment, or serious injury or death. Adjust towing speed for terrain and conditions.
8. **ALWAYS** be careful when backing up with your log splitter in tow. It could jackknife.
9. **ALWAYS** allow for added length of your log splitter when turning, parking and crossing intersections and in all driving situations.
10. **ALWAYS use safety chains when towing your log splitter.**
11. Be extra cautious when towing over rough terrain, especially railroad crossings, and avoid sharp turns and steep angles when towing your log splitter.
12. Never attempt to move this machine over hilly or uneven terrain without a tow vehicle or adequate help.
13. **ALWAYS** disconnect your log splitter from the towing vehicle before operating it.
14. **ALWAYS** check all local and state regulations regarding towing, licensing and lights before towing your log splitter. This machine should not be towed on any street, highway or public road without checking the existing federal, state, or local vehicle requirements. Any licensing or modifications such as taillights, etc., needed to comply, is the sole responsibility of the purchaser. If a “Statement of Origin” is required in your state, see your local dealer.
15. See Transporting the Log Splitter section (Page 26) in this manual for proper towing instructions once all federal, local, or state requirements are met.

**SAVE THESE INSTRUCTIONS**

# ASSEMBLY & SET-UP INSTRUCTIONS

## UNPACKING THE CONTAINER



**WARNING!** Use extreme caution unpacking this machine. Some components are very heavy and will require additional people or mechanical handling equipment.

**NOTE:** All references in this manual to the left or right side and front or back of the log splitter are from the operating position only. Exceptions, if any, will be specified.

### *Unpacking tools needed:*

1. Wrench 13mm
2. Scissors or knife
3. Pry bar or claw hammer

**Step 1:** Use a 13mm wrench to remove the bottom bolts and washers securing the crate side frames onto the crate bottom, and then lift up and put away the crate top with the cardboard box together. See FIGURE 3.

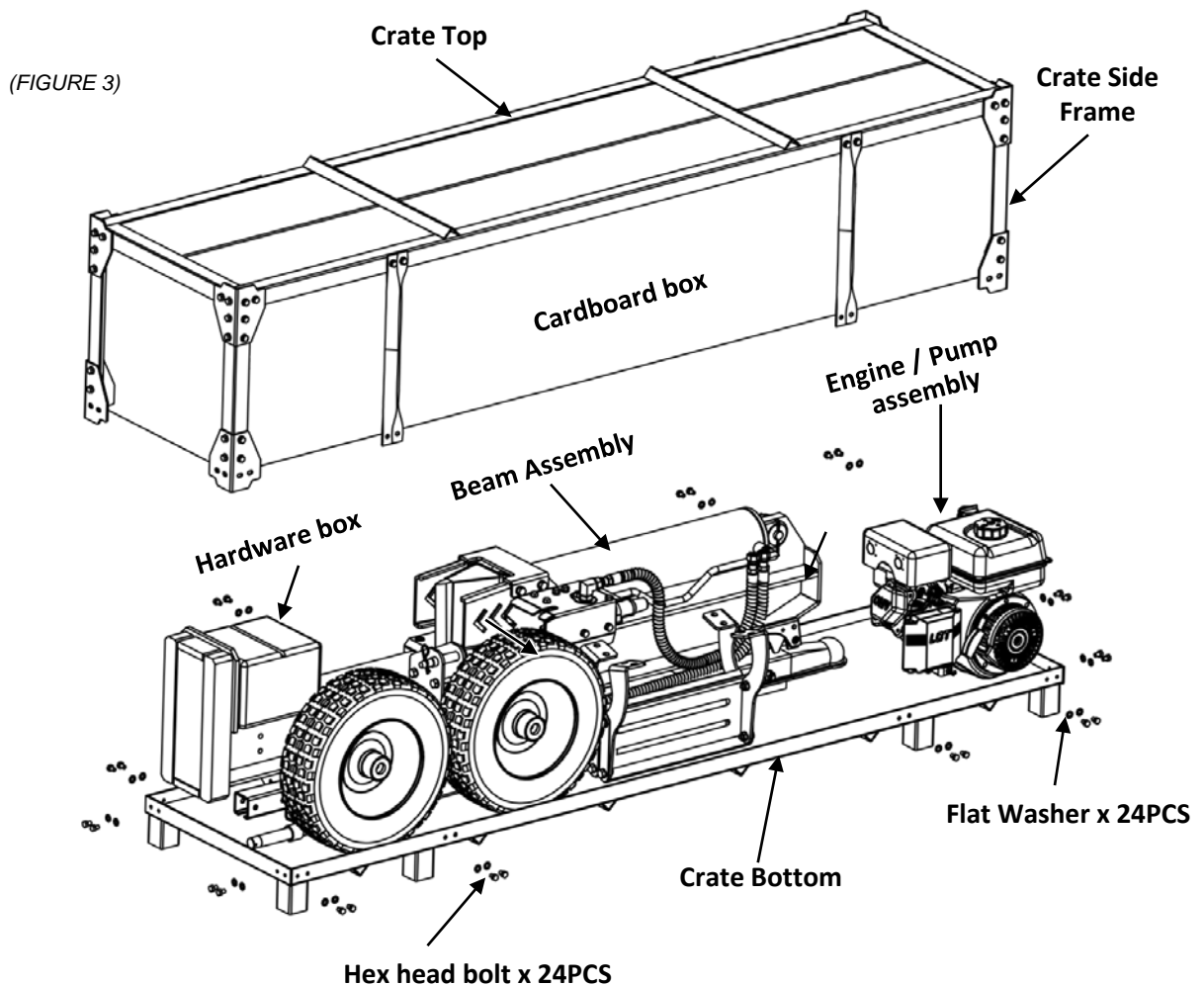

**Step 2:** Remove all loose parts included in the container, e.g. wheels and hardware box.

**Step 3:** Use scissors or a knife to cut and remove the straps securing the parts to the beam or tank assembly, including tongue assembly and log tray assemblies, and put aside these parts for assembly.

***NOTE: DO NOT*** remove the strap securing the hydraulic hoses assemblies to the beam at this time, until you do the assembly procedure of the hoses.

**Step 4:** Use scissors or a knife to cut and remove the straps securing the engine / pump assembly to the crate bottom, and then place aside carefully for assembly.

**Step 5:** Use a pry bar or claw hammer to remove the plywood splinters securing the beam and tank assemblies on the crate bottom. Take out the two heavy assemblies.

***NOTE:*** Due to the weight / size of the two assemblies, it's recommended two or more adults to assist lifting and moving the two assemblies. Lifting tools as hoist, crane, jack, etc. are recommended too.

**Step 6:** Inspect all component assemblies, parts and accessories according to the packing list attached in this manual (Page 35). Make sure all items listed in the packing list are included and of no shipping damage.

**If any parts are damaged or missing, please call our customer service department at 1-800-780-2677 for assistance.**

***NOTE: DO NOT*** discard the packing materials until you have carefully inspected and satisfactorily operated the tool.

# ASSEMBLY & SET-UP INSTRUCTIONS

## ASSEMBLING

**NOTE:** Due to the weight / size of the log splitter, it's recommended that two or more adults be present to assist with the assembling. Some lifting tools such as hoist, crane, jack, etc. are recommended too.

### Assembling tools needed:

- |  |                                 |
|--|---------------------------------|
| 1. Wrench 13mm x 2                           | 6. Needle nose pliers x 1       |
| 2. Wrench 14mm x 2                           | 7. Allen wrench 3mm x 1         |
| 3. Wrench 16, 17, 18, 19, 27, 32 mm one each | 8. Flat head screwdriver x 1    |
| 4. Wrench 1 / 2" x 1                         | 9. Soft faced hammer x 1        |
| 5. Adjustable wrench x 1                     | 10. Thread locking compound x 1 |

### **STEP 1:** Install the two wheels. See FIGURE 4.

1. Raise the reservoir tank assembly off the ground on some blocks before mounting. Remove the plastic shipping caps from the wheels and position the wheels onto the wheel axels.
2. Screw the castle nuts onto the axels and tighten with an adjustable wrench to seat the bearings. Then back the castle nuts off one half turn and snug them up to the bearings by hand, so they line up with the hole in the axel.
3. Insert the split pin into the slot of castle nut and the hole in the axel, then bend the ends of the pin with needle nose pliers keeping it close to the castle nut so the dust cap fits over it.
4. Tap the dust caps onto the wheel using a soft faced hammer.

(FIGURE 4)

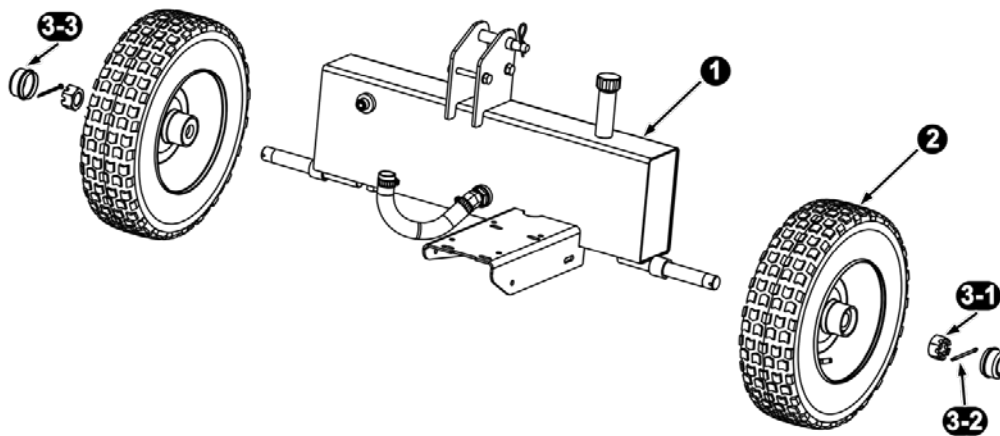

REF. NO.	DESCRIPTION	QTY.
1	Reservoir tank assembly	1
2	Pneumatic tire / Wheel	2
3	Hardware Kit #2, including:	1
3-1	Castle nut / 1-14	2
3-2	Split pin / Ø4 x 50	2
3-3	Dust cap	2

**STEP 2:** Install the tongue assembly to the reservoir tank. See FIGURE 5.

1. Pull out the spring loaded lock handle of flip-down stand which hold the stand on the tongue, and then the stand will automatically flip down towards the ground and be secure in position.
2. Remove the M10 hardware from the beam support bracket on the tank using a 16mm wrench for bolts and a 17mm wrench for the lock nuts. Attach the tongue to the reservoir assembly and screw on the hardware just removed and tighten.

(FIGURE 5)

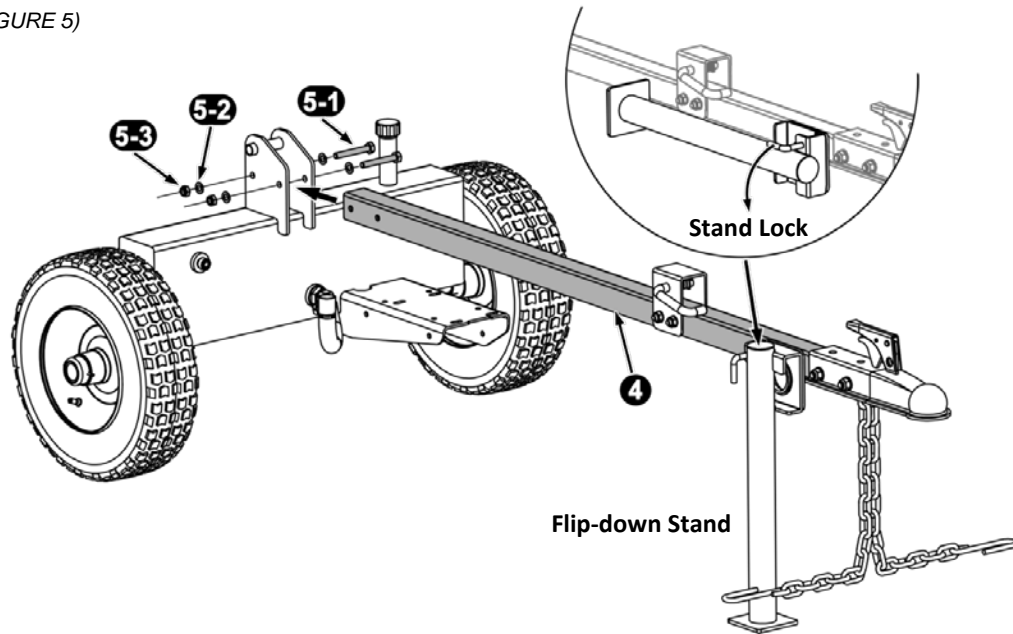

REF. NO.	DESCRIPTION	QTY.
4	Tongue & Flip-down stand assembly	1
5	M10 Hardware on beam support bracket, including:	1
5-1	Hex head bolt / M10 x 75	2
5-2	Flat washer / M10	4
5-3	Lock nut / M10	2

**STEP 3:** Install the engine / pump assembly to the engine mount plate on the reservoir assembly. See FIGURE 6.

1. Insert a vibration isolator between the engine and the mount plate at each of the four mounting hole positions.
2. Secure the engine with the hardware, then tighten the hardware using two 13mm wrenches for 22 / 25 / 28 ton model; or 16mm wrench on bolts, 17mm wrench on lock nuts for 30 / 35 ton model.

(FIGURE 6)

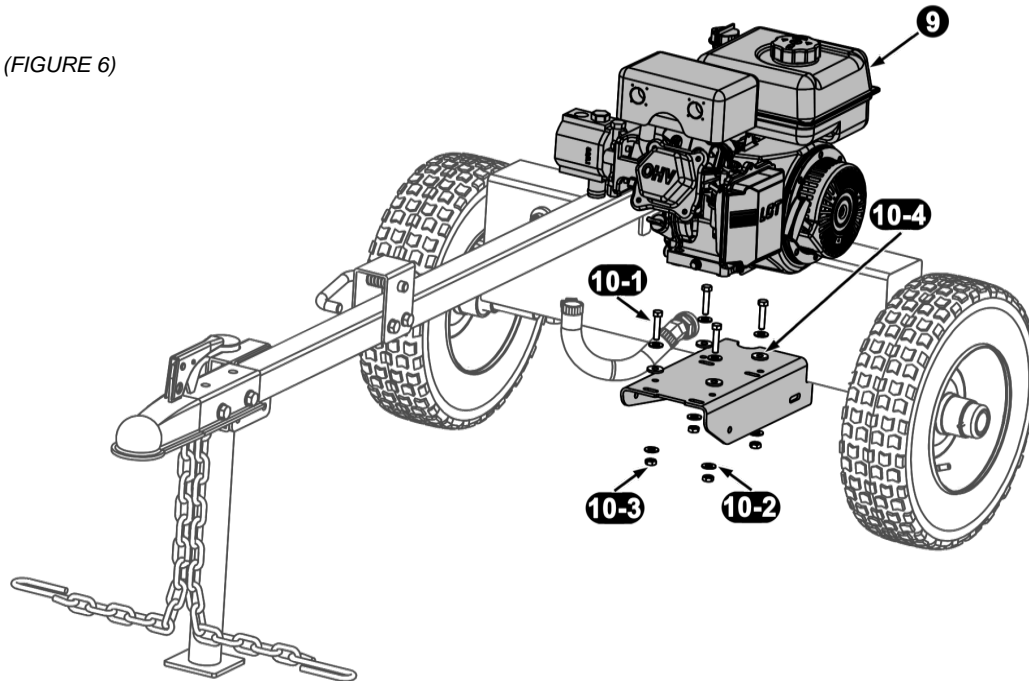

REF. NO.	DESCRIPTION	QTY.
9	Engine / Pump assembly	1
10	Hardware kit # 5-1 (22 / 25 / 28T) or # 5-2 (30 / 35T),	1
10-1	Hex head bolt / M8 x 40 (22 / 25 / 28T) or M10 x 40 (30 / 35T)	4
10-2	Flat washer / M8 (22 / 25 / 28T) or M10 (30 / 35T)	8
10-3	Lock nut / M8 (22 / 25 / 28T) or M10 (30 / 35T)	4
10-4	Vibration isolator / Ø9 (22 / 25 / 28T) or Ø11 (30 / 35T)	4
//	O Seal ring / Ø15*1.9	2

**NOTE:** In the Hardware Kit # 5-1 or 5-2, you have one O seal ring / Ø15\*1.9, which is a spare O ring to be used in the “STEP 6: Connect hydraulic hoses” section if you can’t find one sitting in the fitting slot on the reservoir tank, when you attach the oil return hose (3) to the reservoir tank.

**STEP 4:** Install the beam assembly. See FIGURE 7.

1. Stand the beam upright on a flat level. Two or more people are recommended to assist with raising and lowering the beam as it is very heavy. Have a helper support the beam as you perform the following steps. Be sure to keep hands away from any possible pinch points.
2. Remove the clevis pin and spring clip from the beam support bracket on the tank. Position the tongue / tank assembly so that the beam support bracket is in between the two tabs on the beam.
3. Slide the clevis pin through the aligned holes and secure with the spring clip. You may need another helper to lift up the tongue for the holes to align.
4. Leave the beam in the vertical position for continual assembling steps.

(FIGURE 7)

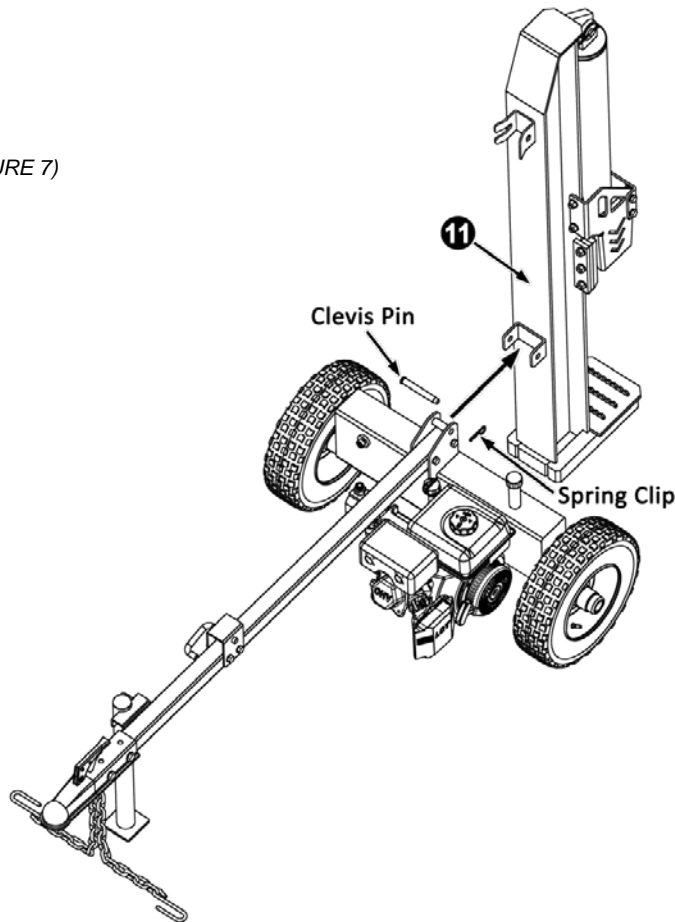

REF. NO.	DESCRIPTION	QTY.
11	Beam assembly	1



**WARNING!** Take extra care when raising and lowering the beam as it is fairly heavy. Having a second person assist with raising or lowering the beam is recommended. Be sure to keep hands away from any possible pinch points.

**STEP 5:** Connect hydraulic hoses. See FIGURE 8.

There are three hydraulic hoses listed below, each of them has one end fixed on the log splitter by manufacturer, and the other open end still needs to be attached. The hoses are labeled on the ends for easy installation.

1. Oil suction hose  $\frac{3}{4}$ " , labeled as ①, comes from the bottom of the reservoir.  
Loosen the hose clamp on the open end of this hose using a flat head screwdriver, and then connect the hose to the fitting on the bottom of the pump, which is also labeled as ①. Tighten the hose clamp.
2. Pump / Valve connecting hose  $\frac{1}{2}$ " , labeled as ②, comes from the bottom of the valve on the beam assembly.  
Screw the open end of this hose onto the fitting on top of the pump, which is also labeled as ②. Tighten using a 27mm wrench or an adjustable wrench.
3. Oil return hose  $\frac{3}{4}$ " , labeled as ③, comes from the top of the valve on the beam assembly.  
Screw the open end of this hose onto the fitting on the reservoir tank, which is also labeled as ③. Make sure an O-ring  $\varnothing 15 \times 1.9$  sitting inside the fitting slot. Or you could find a spare O-ring in your hardware kit # 5-1 or 5-2 (See page 15). Tighten the hose using a 32mm wrench or an adjustable wrench.

(FIGURE 8)

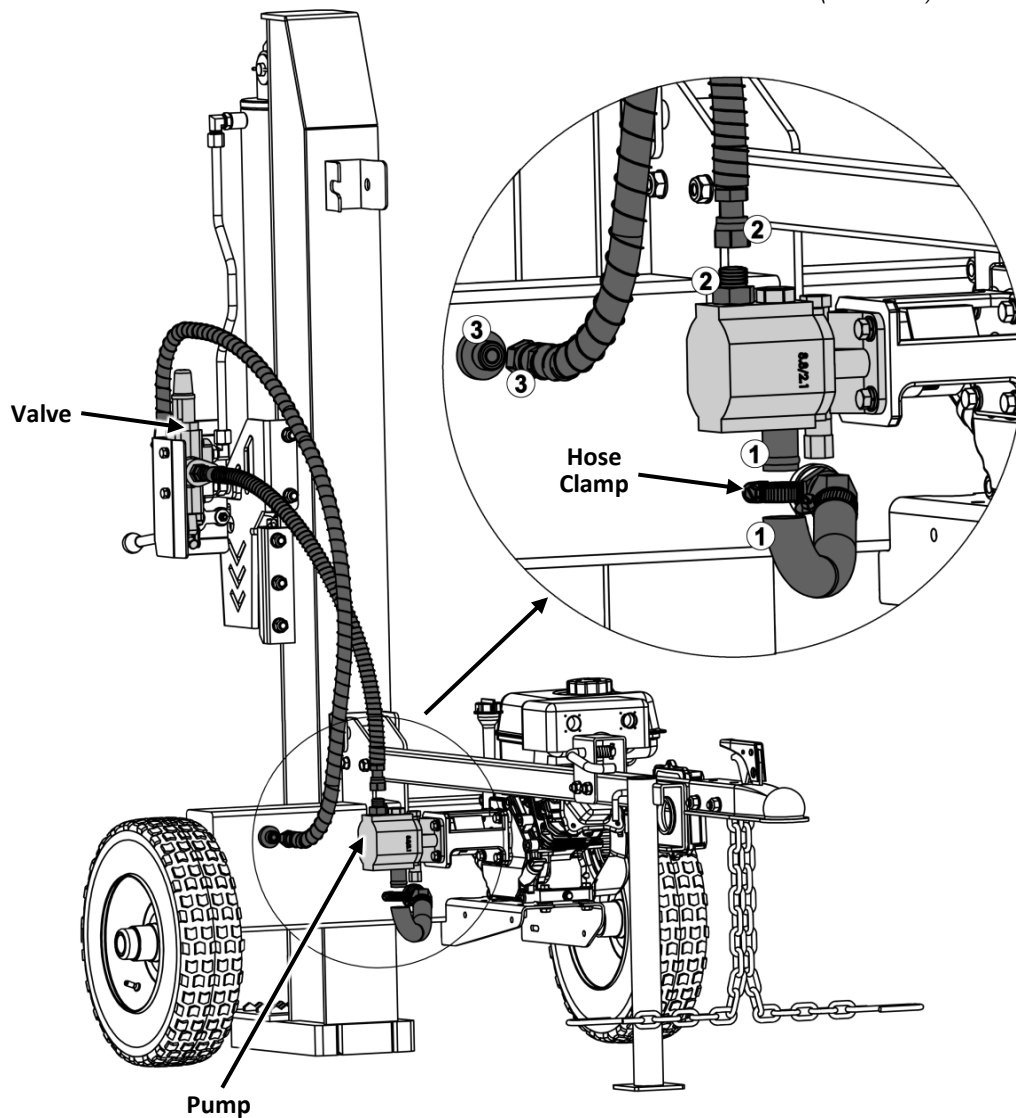

**STEP 6:** Install the log tray assemblies. See FIGURE 9.

1. Lower the beam to horizontal position. Please refer to “Beam Operating Positions” section in Page 23.
2. Position the log tray frames onto the beam as shown below and secures with the M10 hardware loosely.
3. Tighten the M10 hardware using an 16mm wrench on the bolts, and a 17mm wrench on the lock nuts

(FIGURE 9)

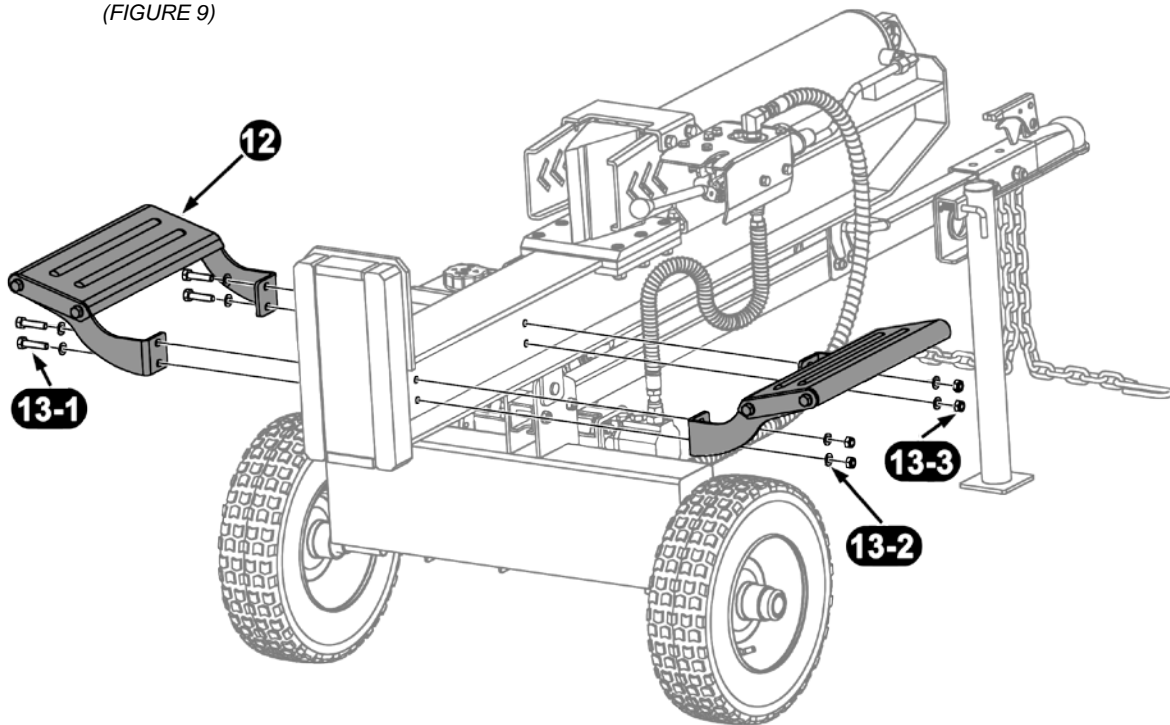

REF. NO.	DECSRIPTION	QTY.
12	Log tray assembly	2
13	Hardware Kit # 6-1, including:	1
13-1	Hex head bolt / M10 x 45	4
13-2	Flat washer / M10	8
13-3	Lock nut / M10	4

**STEP 7:** Assemble the control handle. See FIGURE 10.

The control handle is shipped hanging from the valve on the handle link.

1. Remove the clevis pin and bow-tie cotter pin from the valve.
2. Rotate the control handle up into the operating position and secure with the clevis pin and cotter pin just removed.

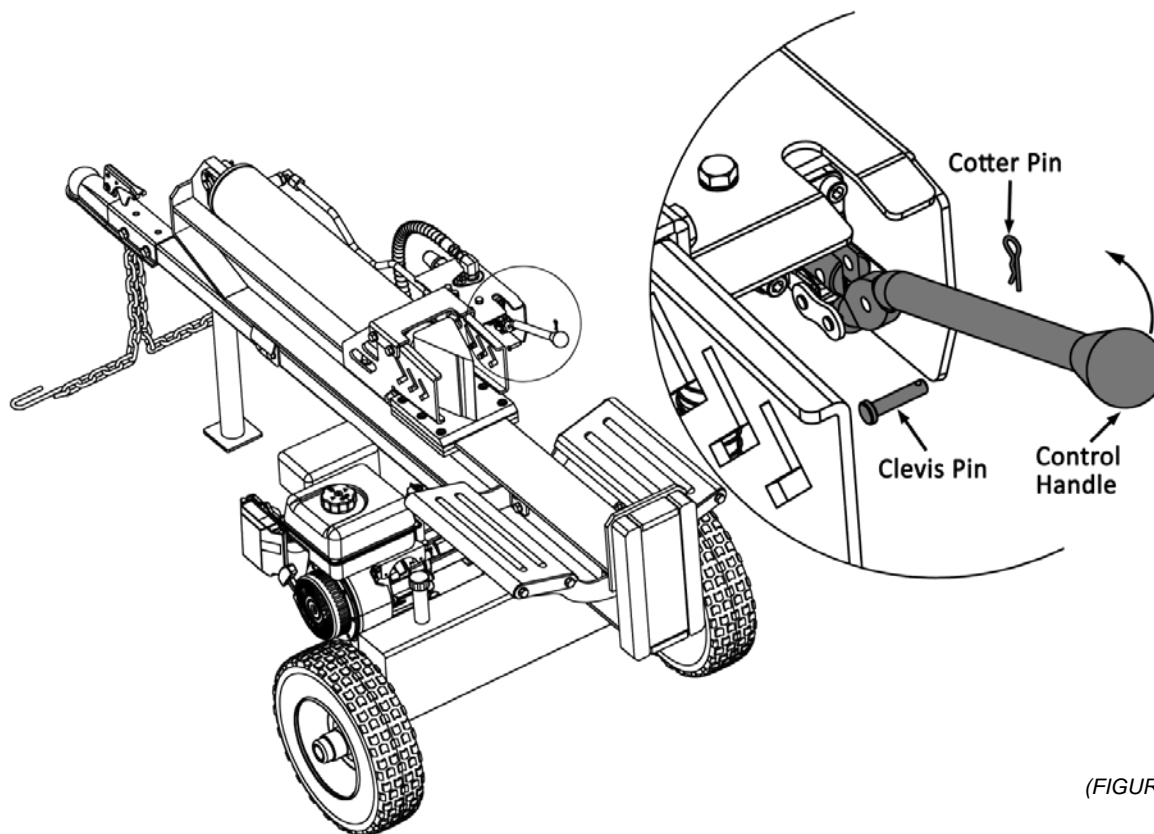

(FIGURE10)

# ASSEMBLY & SET-UP INSTRUCTIONS

## SET-UP

### Gas and Oil Fill-Up

Service the engine with gasoline and engine oil as instructed in the engine manual packed with your log splitter. Read the instructions carefully.



**WARNING!** Use extreme care when handling gasoline. Gasoline is extremely flammable and the vapors are explosive. Never fuel the machine indoors or while the engine is hot or running.

**NOTE:** Your log splitter may be shipped without engine oil. You **MUST** check the oil level before operating. Be careful not to overfill. Gasoline can be added to the engine when the log splitter is in either the horizontal or vertical position. However, it may be easier when the splitter is in the vertical position.

### Adjust Handle Release Lever

Your log splitter is equipped with an external pressure release system which is attached under the valve bracket. When you set up the machine and try it, you will see the back of the wedge hits the handle release lever when the wedge is fully retracted. The control handle is then kicked back from reverse position to the neutral position automatically.

The lever may need to be adjusted if the wedge is fully retracted and the control lever does not automatically kick into neutral.

To adjust the handle release lever, See FIGURE 11

1. Loosen the Jam nut using a 14mm wrench.
2. Screw the adjusting nut counter clockwise to allow it contact with the wedge as soon as the wedge is fully retracted.
3. Tighten the jam nut after adjusting.

### Lubricate the Beam

Lubricate the beam area (where the splitting wedge will slide) with engine oil. Do not use grease. See FIGURE 12.

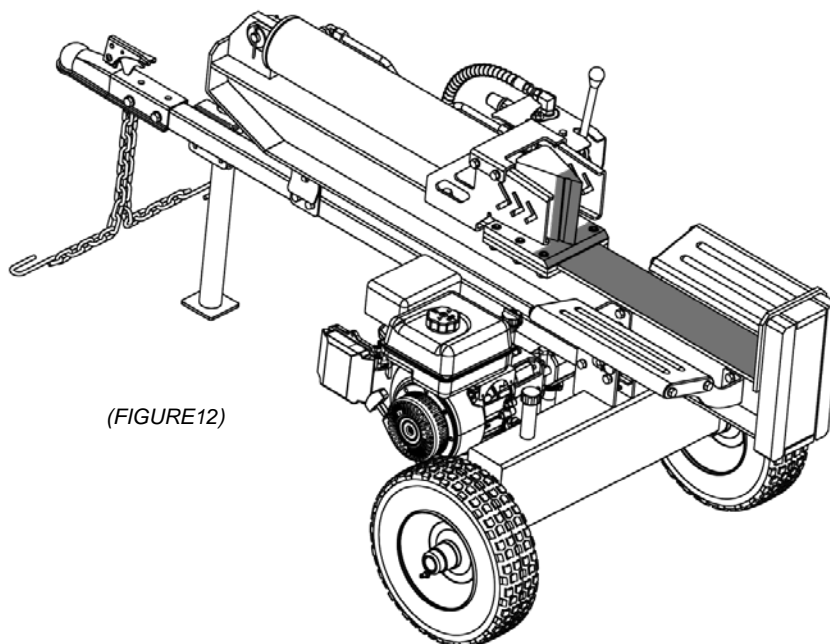
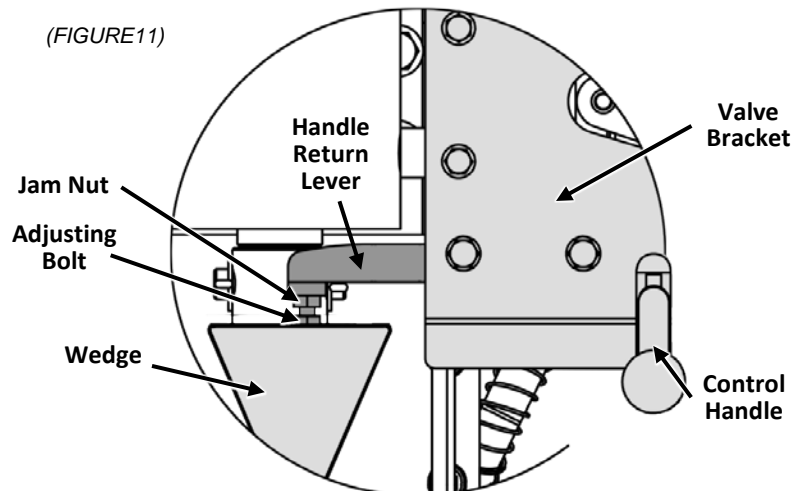

## Fill hydraulic oil

The log splitter is shipped without hydraulic fluid in the reservoir. Fill the reservoir before your initial use.

1. Remove the vented reservoir dipstick, which is located next to the engine on top of the reservoir tank.  
See FIGURE 13.

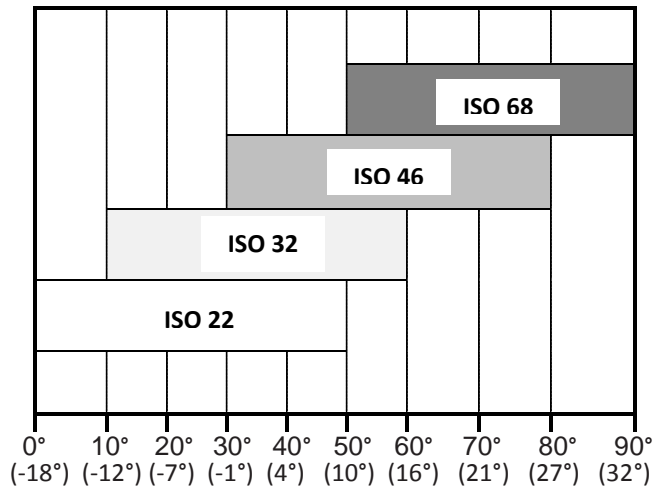

Please select the oil based on the outside temperature range the log splitter will be used in. Refer to the chart provided to select the appropriate hydraulic oil.

Approved fluids include Shell Tellus® S2 M 32 Hydraulic Fluid, Dexron® III / Mercon® automatic transmission fluid, Pro-Select™ AW-32 Hydraulic Oil or 10WAW-ISO viscosity grade 32 hydraulic oil. It is not recommended that fluids be mixed, to top off the reservoir tank during initial set-up use Shell Tellus® S2 M 32 Hydraulic Fluid only.

2. Slowly fill the reservoir with the recommended hydraulic oil until oil level reaches the maximum line on the dipstick.
3. Replace the vented dipstick in the reservoir.
4. Start the engine, and use the control handle to engage the wedge to the farthest extended position and then retract. Repeat this operation for 12 cycles. Much of the fluid will be drawn into the cylinder and hoses. Stop the engine, and check the oil level as instructed below.

**NOTE:** Make sure the oil level is above the bottom line on the dipstick. If not, refill the reservoir to prevent damage to the hydraulic pump. **DO NOT overfill.** Some fluid may overflow from the vent plug as the system builds heat and the fluid expands and seeks a balanced level.

5. However, you **MUST** check the fluid level before each operating. If not filled, proceed with above steps.

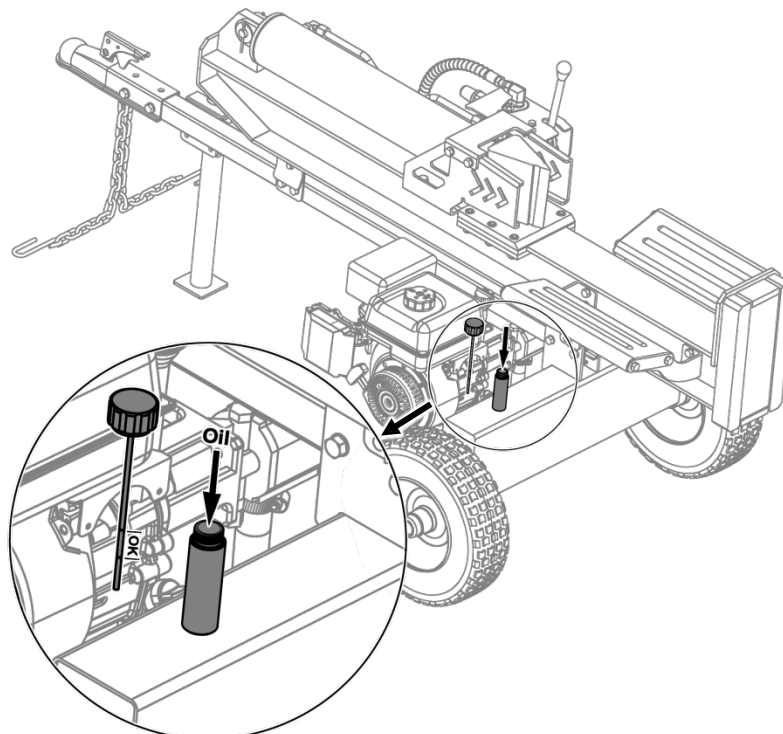

(FIGURE13)

## Know Controls and Features

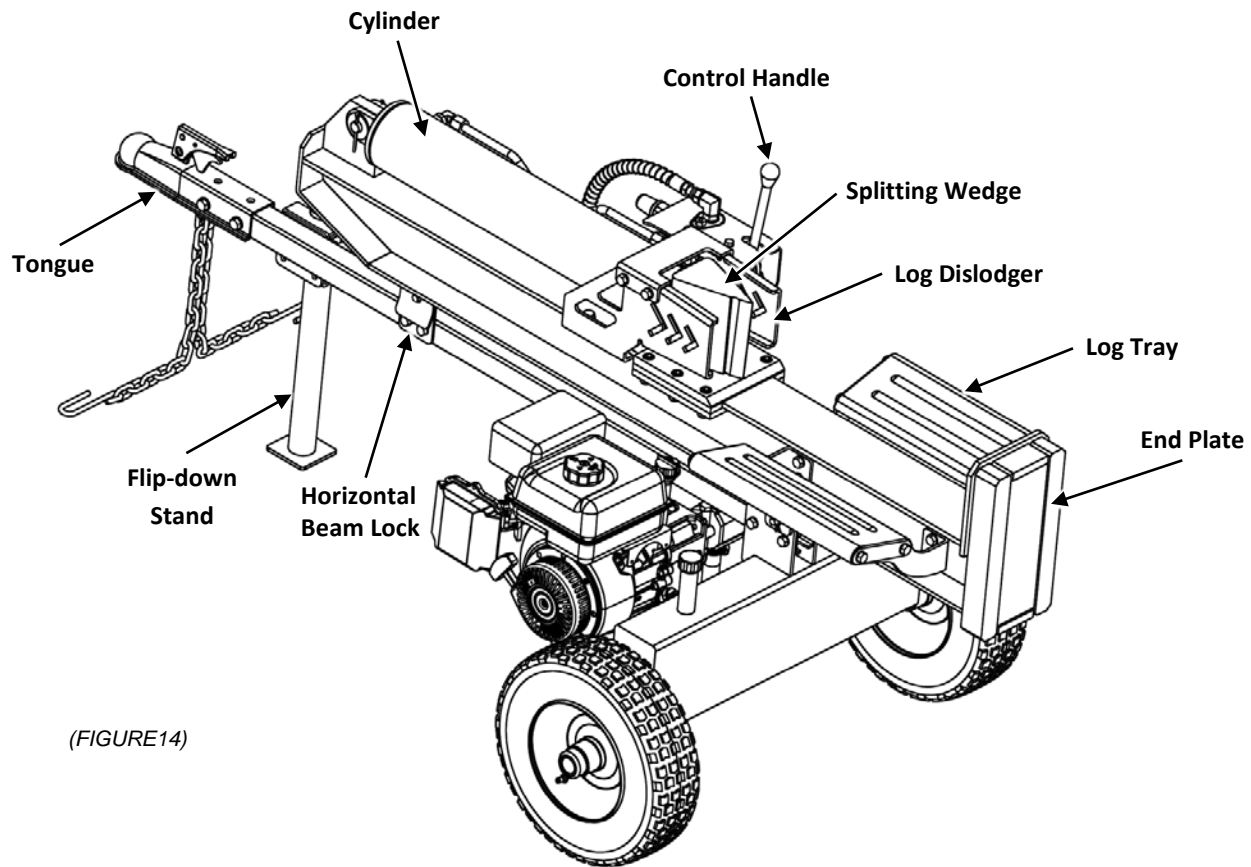

(FIGURE14)

**NOTE:** This Operator's Manual covers several models. Log splitter features may vary by model. Not all features in this manual are applicable to all log splitter models and the log splitter depicted may differ from yours.

### Beam Lock

The horizontal beam lock, as its name suggests, is used to secure the beam in the horizontal position. The horizontal beam lock is located on the beam support latch bracket.

### Engine Controls

See the Engine Operator's Manual for the location and function of the controls on the engine.

### Control Handle

The control handle has three positions; Forward, Neutral and Reverse. See the Operation section for instructions

### . Splitting Wedge

The wedge is used to split the wood.

### Log Dislodger

The log dislodgers are designed to remove any partially split wood from the wedge. This may occur while splitting large diameter wood or freshly cut wood.

### Log Tray

The log trays are designed to catch the log after it is split.

### Tongue

The tongue is used to attach to a towing vehicle for transportation.

### End Plate

The end plate holds the log in place while the wedge splits the log.

# OPERATION INSTRUCTIONS

## STARTING & STOPPING THE ENGINE

Refer to the Engine Operator's manual packed with your log splitter for instructions on starting and stopping the engine.

## BEAM OPERATING POSITIONS

1. Place the log splitter on flat, dry, solid ground.
2. Block both wheels to prevent your log splitter from moving during operation. See FIGURE 15.
3. Place the beam in either the horizontal or vertical position and lock into place.



**WARNING!** Take extra care when raising and lowering the beam as it is fairly heavy. Having a second person assist with raising or lowering the beam is recommended. Be sure to keep hands away from any possible pinch points.



**WARNING!** Always use the log splitter in the vertical position when splitting heavy logs.

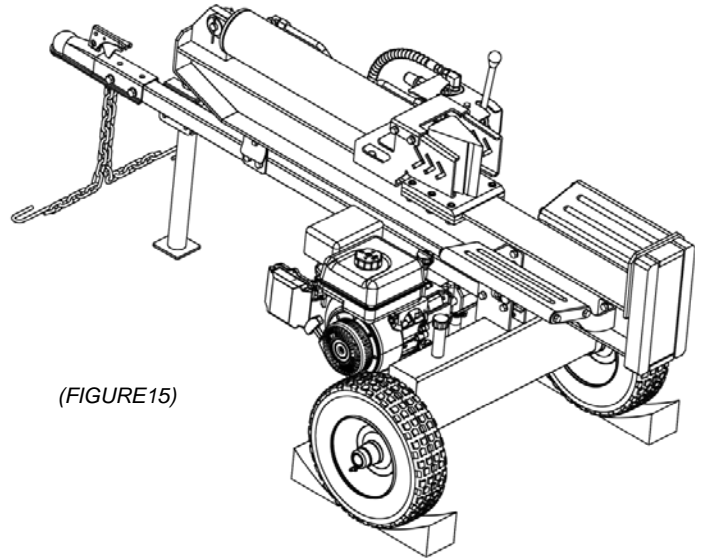

(FIGURE 15)

4. To place the beam in the *Vertical Position* proceeds as follows:
  - 1) Pull the horizontal beam lock lever out and rotate it downward, so it rests against the side of the lock and remains unlocked. See FIGURE 16.
  - 2) Use both your hands to lift up the beam, and flip it over to the vertical position, then rotate the horizontal lock lever back up the tongue to release the lock.
5. To place the beam in the *Horizontal Position* proceeds as follows:
  - 1) Pivot the beam to the horizontal position.
  - 2) The horizontal beam lock is self-locking. The spring loaded lock will snap into place when the beam is lowered into position.

(FIGURE 16)

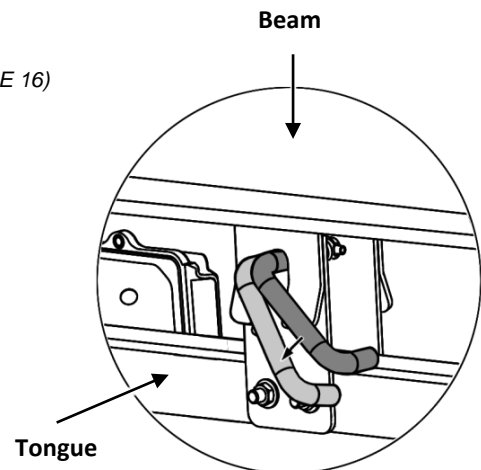

# OPERATION INSTRUCTIONS

## USING CONTROL HANDLE

The control handle has three positions. See FIGURE 17.

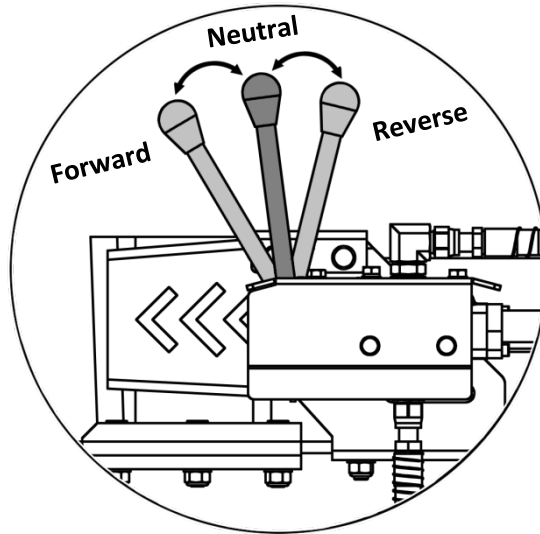

(FIGURE 17)

- **FORWARD** — To split wood. Move the control handle to the FORWARD position to move wedge toward the log to split.  
**NOTE:** The control handle will return to the NEUTRAL position as soon as the handle is released (FORWARD position only), and the wedge stops moving forward.
- **NEUTRAL** — To stop wedge. Release the control handle or move the lever to the NEUTRAL position to stop the wedge movement.
- **REVERSE** — To return the wedge. Engage the control handle to the REVERSE position, the wedge will automatically return toward the cylinder. When the wedge is fully retracted and contacts the handle release lever, the control handle will return to the NEUTRAL position automatically.

**NOTE:** Do not hold the handle in the REVERSE position. It will stay in REVERSE position during the wedge being retracted automatically. When the wedge is fully retracted, the handle will kick back to the NEUTRAL position by itself.



**WARNING!** If the control handle on your log splitter is not functioning properly, STOP USE IMMEDIATELY and contact an authorized service dealer.



**WARNING!** Do not attempt to service, repair or replace control valve. Contact an authorized service dealer.



**WARNING!** Do not attempt to adjust or modify the control valve or the hydraulic system from its original settings or manufacturer in any way.

# OPERATION INSTRUCTIONS

## SPLITTING THE WOOD

1. Start the engine as instructed in the Engine Operator's manual included with the log splitter.
2. Grasp the log on the sides and place it on top of the beam against the end plate. Always split the wood in the direction of the grain. See FIGURE 18.
3. To stabilize the log, place your left hand on the side of the log. See FIGURE 18.



**WARNING!** Never place your hand on the ends of the log, between the log and the end plate or the log and the splitting wedge.



**WARNING!** Only one operator permitted. The adult who loads and stabilizes the log, must be the person who operates the control handle.

4. Use your right hand to push the control handle lever to the forward position to split the wood.
5. Remove left hand from the log once the wedge begins to contact with the log. Continue holding the control handle in the forward position until the log splits.
6. Release the control handle to stop the wedge movement at any point in the splitting process if you feel an unsafe splitting condition is occurring. **NEVER** reach forward and attempt to catch a falling piece of wood---let it fall.
7. Once the log is split or the wedge is fully extended, move the control handle to the reverse position to return the wedge. **DO NOT** hold the handle at Forward position as soon as the wedge is fully extended. Or the hydraulic system will get damaged, and void your warranty.

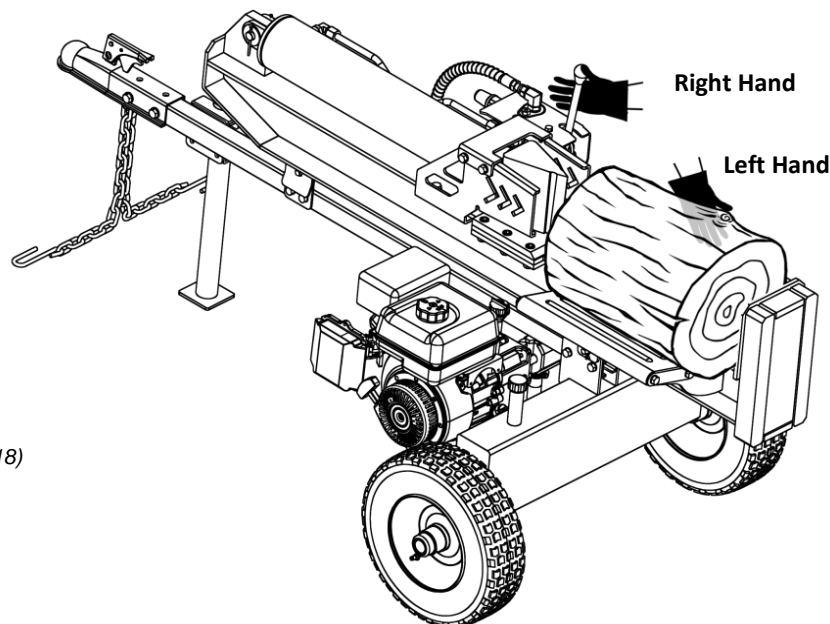

(FIGURE18)

8. Remove partially split wood from wedge.
  - 1) Move the control handle to the REVERSE position until the wedge is fully retracted to allow the partially split wood to contact the log dislodger.



**WARNING!** Never remove partially split wood from the wedge with your hands. Fingers may become trapped between the split wood.

- 2) Once removed from the wedge with the log dislodger, split the wood from the opposite end or in another location.

# OPERATION INSTRUCTIONS

## TRANSPORTING THE LOG SPLITTER

1. Lower the beam to its horizontal position. Make certain the beam is locked securely with the horizontal beam lock.
2. Pivot the flip-down stand up to transporting position.
  - 1) Pull out the lock handle of the stand and rotate it up. The stand will be secured horizontally with the tongue automatically. Please refer to FIGURE 5 on page 14.
  - 2) Have a helper to support the tongue, or use a wheeled trailer jack to raise the tongue (optional accessory from the Manufacturer).

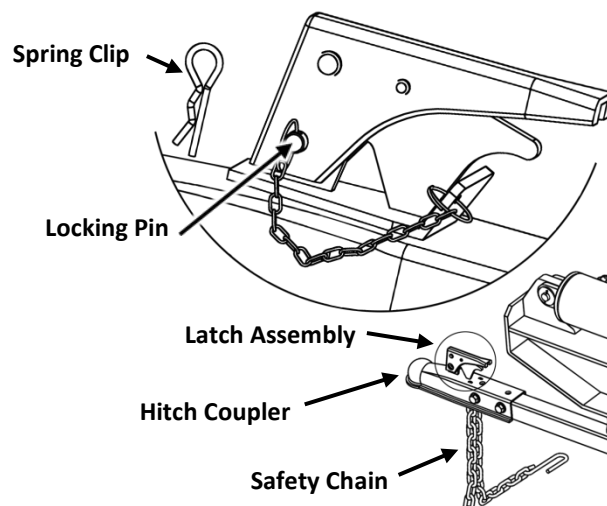

(FIGURE 19)

3. Pull the latch on the hitch coupler up, position the coupler over onto to the tow ball behind your towing vehicle, and then close the latch to lock the ball securely. See FIGURE 19
  - 1) If the coupler hitch is too tight and does not fit onto the ball, turn the adjustment nut one turn counter-clockwise.
  - 2) If the coupler hitch is too loose on the ball, turn the adjustment nut one turn clockwise, then recheck and adjust accordingly.
4. Attach the safety chains to the towing vehicle crossing each other under the tow ball, ensuring there is enough slack for turning.
5. Insert the locking pin into the hole in the latch assembly and lock with the spring clip.



**WARNING!** Do not tow faster than 45mph and check the local, state and federal requirements before towing on any public road.

**NOTE:** Use caution when backing up. Using a spotter outside the vehicle is recommended.

# MAINTENANCE & ADJUSTMENTS

Regular maintenance is the way to ensure the best performance and long life of your machine. Please refer to this manual and the engine manufacturer's owner's manual for maintenance procedures.



**WARNING!** Do not make any adjustments without first stopping the engine, disconnecting the spark plug wire and grounding it against the engine. Always wear safety glasses during operation or while performing any adjustments or repairs.

## **Engine**

Refer to the Engine Operator's manual packed in the hardware kit box of your log splitter for all engine maintenance e.g. how to check and change the engine oil.

**NOTE:** When draining oil from the engine on this log splitter, shield the hoses from any oil that may run down the frame and drip onto the hoses. Thoroughly wipe any residual oil off the log splitter and hoses after completing service.

## **Tire Pressure**

The tires are off-road tires. The max recommended operating pressure is 30 psi. Do not, under any circumstances, exceed the manufacturer's recommended psi. Maintain equal pressure on both tires.



**WARNING!** Excessive pressure when seating beads may cause the tire/rim assembly to burst with force sufficient to cause serious injury.

## **Flexible Pump Coupler**

The flexible pump coupler, located between the pump and the engine shaft, has a nylon "spider" insert. Over time, the insert will harden and deteriorate. If you detect vibration or noise coming from the area between the engine and the pump, contact an authorized dealer or Boss Industrial, Inc. Make sure to change a new coupler spider immediately when the coupler spider fails completely, or you will experience a loss of hydraulic power.

## **Hydraulic Fluid**

Check the hydraulic fluid level in the log splitter reservoir tank before each use. Maintain the fluid level within the range specified on the dipstick at all times.

Change the hydraulic fluid in the reservoir every 100 hours of operation. Follow the steps below:

1. Place a suitable oil collection container under the tank.
2. Disconnect the oil drain plug from the bottom of the reservoir tank. See FIGURE 20.
4. Allow the fluid to drain into the container.

**NOTE:** The reservoir tank has a capacity of 4 gallons of hydraulic fluid for 22 / 25 / 28 / 30 ton; and 5 gallons for 35 ton log splitter.

5. After draining, put the oil drain plug back in and tighten.

(FIGURE20)

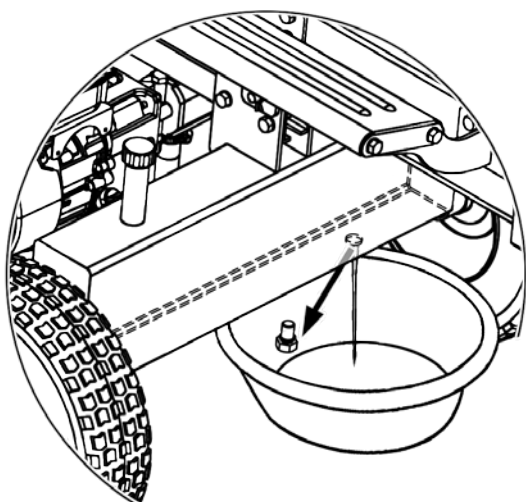

(FIGURE21)

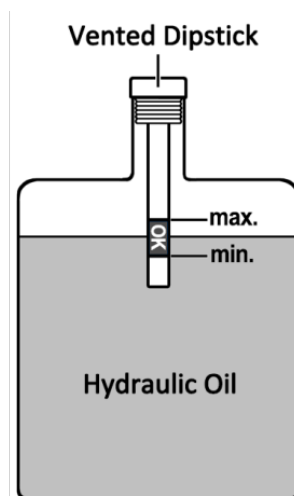

6. Refill the reservoir tank (Please follow the steps in Page 21 to fill the tank, and repel the air in the tank).
7. Maintain the fluid level within the range specified on the dipstick at all times. See FIGURE 21.

**NOTE:** When checking the fluid, always make sure to push the dipstick all the way down to make sure you are getting an accurate reading.

**NOTE:** Always dispose of any used hydraulic fluid and engine oil at approved oil recycling centers only. Contaminants in the fluid may damage the hydraulic components. Flushing the reservoir tank and hoses with kerosene whenever service is performed on the tank, hydraulic pump or valve is recommended.

### **Beam and Splitting Wedge**

Lubricate top, sides and bottom of the beam and where it comes into contact with the splitting wedge with engine oil before each use.

If the wedge becomes dull or nicked, it can be sharpened.

### **Off-Season Storage**

If the log splitter will not be used for more than 30 days, prepare it for storage as follows:



**WARNING!** Never store the machine with fuel in the fuel tank inside of building where fumes may reach an open flame or spark, or an ignition source such as hot water or space heaters, furnaces, clothes dryers, stoves, electric motors, etc.

1. Refer to the Engine Operator's manual packed with your log splitter for information on the off-season storage of the engine.
2. Clean the log splitter thoroughly.

**NOTE:** The use of pressure washers or a garden hose to clean the splitter is not recommended. They may cause damage to the bearings or the engine. The use of water will result in a shortened life and reduce serviceability.

3. Wipe the machine with an oiled rag to prevent rust, especially on the wedge and the beam.
4. Store the log splitter in a clean, dry area. Do not store it next to corrosive materials, such as fertilizer.

**NOTE:** If storing in an unventilated or metal storage shed, be certain to rustproof the equipment by coating it with a light oil or silicone. A log splitter cover from the manufacturer is recommended.

# TROUBLESHOOTING

Most problems are easy to fix. Consult the trouble shooting Table below for common problems and their solutions. If you continue to experience problems, contact us at [www.boss-industrial.com](http://www.boss-industrial.com), or call toll-free (800) 780 2677 for support.

If the machine should start making an unusual noise or vibration, shut down the engine, wait 5 minutes for machine to cool down, then inspect for damage. Vibration is generally a warning of trouble. Check for damaged parts and clean, repair and / or replace as necessary.

Problem	Cause	Remedy
Cylinder rod will not move	<ol style="list-style-type: none"> <li>1. Broken drive shaft.</li> <li>2. Shipping plugs left in hydraulic hoses.</li> <li>3. Set screws in coupling not adjusted properly.</li> <li>4. Loose shaft coupling.</li> <li>5. Gear sections damaged.</li> <li>6. Damaged relief valve.</li> <li>7. Hydraulic lines blocked.</li> <li>8. Low oil level or air trapped in hydraulic system.</li> <li>9. Damaged control valve.</li> <li>10. Blocked control valve.</li> </ol>	<ol style="list-style-type: none"> <li>1. See authorized service dealer.</li> <li>2. Disconnect hydraulic hoses, remove shipping plugs, and reconnect hoses.</li> <li>3. See authorized service dealer.</li> <li>4. Correct engine/pump alignment as necessary.</li> <li>5. See authorized service dealer.</li> <li>6. See authorized service dealer.</li> <li>7. Flush and clean hydraulic system.</li> <li>8. Fill oil or bleed air.</li> <li>9. See authorized service dealer.</li> <li>10. Flush and clean hydraulic system</li> </ol>
Slow cylinder shaft speed while extending and retracting	<ol style="list-style-type: none"> <li>1. Gear sections damaged.</li> <li>2. Excessive pump inlet vacuum.</li> <li>3. Slow engine speed.</li> <li>4. Damaged relief valve.</li> <li>5. Low oil level or air trapped in hydraulic system.</li> <li>6. Contaminated oil.</li> <li>7. Control valve leaking internally.</li> <li>8. Internally damaged cylinder.</li> </ol>	<ol style="list-style-type: none"> <li>1. See authorized service dealer.</li> <li>2. Make certain pump inlet hoses are clear and unblocked. use short, large diameter inlet hoses.</li> <li>3. See authorized service dealer.</li> <li>4. See authorized service dealer.</li> <li>5. Fill oil or bleed air.</li> <li>6. Drain oil, clean reservoir and refill.</li> <li>7. See authorized service dealer.</li> <li>8. See authorized service dealer</li> </ol>
Leaking Cylinder	<ol style="list-style-type: none"> <li>1. Worn seals.</li> <li>2. Scored cylinder.</li> </ol>	<ol style="list-style-type: none"> <li>1. See authorized service dealer.</li> <li>2. See authorized service dealer.</li> </ol>
Wood will not split or wood splits too slowly	<ol style="list-style-type: none"> <li>1. Small gear section damaged.</li> <li>2. Pump check valve leaking.</li> <li>3. Excessive pump inlet vacuum.</li> <li>4. Low oil level or air trapped in hydraulic system.</li> <li>5. Contaminated oil.</li> <li>6. Control valve leaking internally.</li> <li>7. Overloaded cylinder.</li> <li>8. Internally damaged cylinder.</li> </ol>	<ol style="list-style-type: none"> <li>1. See authorized service dealer.</li> <li>2. See authorized service dealer.</li> <li>3. Make certain pump inlet hoses are clear and unblocked.</li> <li>4. Fill oil or bleed air.</li> <li>5. Drain oil, clean reservoir and refill.</li> <li>6. See authorized service dealer.</li> <li>7. Do not attempt to split wood against the grain.</li> <li>8. See authorized service dealer.</li> </ol>
Leaking pump shaft seal	<ol style="list-style-type: none"> <li>1. Broken drive shaft.</li> <li>2. Engine/pump misalignment.</li> <li>3. Gear sections damaged.</li> <li>4. Damaged shaft seal.</li> <li>5. Plugged oil breather.</li> </ol>	<ol style="list-style-type: none"> <li>1. See authorized service dealer.</li> <li>2. Correct alignment as necessary.</li> <li>3. See authorized service dealer.</li> <li>4. See authorized service dealer.</li> <li>5. Make certain reservoir is properly vented.</li> </ol>
Wedge continues to move forward when control handle is released	<ol style="list-style-type: none"> <li>1. Damaged control valve</li> </ol>	<ol style="list-style-type: none"> <li>1. See authorized service dealer.</li> </ol>
Control handle does not return to neutral when released from forward position	<ol style="list-style-type: none"> <li>1. Hydraulic fluid too cold.</li> <li>2. Hydraulic fluid too thick.</li> <li>3. Hydraulic fluid contaminated.</li> <li>4. Damaged control valve.</li> </ol>	<ol style="list-style-type: none"> <li>1. Warm up engine.</li> <li>2. Replace hydraulic fluid.</li> <li>3. Replace hydraulic fluid.</li> <li>4. See authorized service dealer.</li> </ol>

# SPECIFICATIONS

Model	WD22T	WD25T	WD28T	WD30T	WD35T	
Engine	See engine manual	See engine manual	See engine manual	See engine manual	See engine manual	
Pump	Two-Stage, 11 gpm	Two-Stage, 11 gpm	Two-Stage, 11 gpm	Two-Stage, 16 gpm	Two-Stage, 16 gpm	
Cylinder (Bore x Stroke)	4 in. x 21.6 in.	4 in. x21.6 in.	4.5 in. x 21.6 in.	4.5 in. x 21.6 in.	5 in. x 21.6 in.	
Maximum Splitting Force	22 Tons*	25 Tons*	28 Tons*	30 Tons*	35 Tons*	
Hydraulic Pressure	3400 psi*	3650 psi*	3400 psi*	3600 psi*	3400 psi*	
Maximum Log Length	24 in.	24 in.	24 in.	24 in.	24 in.	
Wedge Height	7 in.	7 in.	7 in.	7 in.	7 in.	
Cycle Time	Forward	7 Seconds*	7 Seconds*	7.5 Seconds*	7 Seconds	8 Seconds*
	Reverse	5 Seconds*	5 Seconds*	6 Seconds*	5.5 Seconds	6.5 Seconds*
Wheels	16 x 4.8 x 8 in.	16 x 4.8 x 8 in.	16 x 4.8 x 8 in.	16 x 4.8 x 8 in.	16 x 4.8 x 8 in.	
Hydraulic Capacity	4 Gallons	4 Gallons	4 Gallons	4 Gallons	5 Gallons	
Height (Horizontal / Vertical Position)	39.5 / 67 in.	39.5 / 67 in.	39.5 / 67 in..	39.5 / 67 in.	39.5 / 67 in.	
Length (Horizontal / Vertical Position)	85.5 / 84 in.	85.5 / 84 in.	85.5 / 84 in.	85.5 / 84 in.	85.5 / 84 in.	
Width	40 in.	40 in.	40 in.	40 in.	40 in.	
Net Weight	471 lbs	474 lbs	515 lbs	530lbs	572 lbs	

\*Tonnage and cycle times may vary dependent upon mechanical and environmental conditions.

# EXPLODED DIAGRAM & PARTS LIST

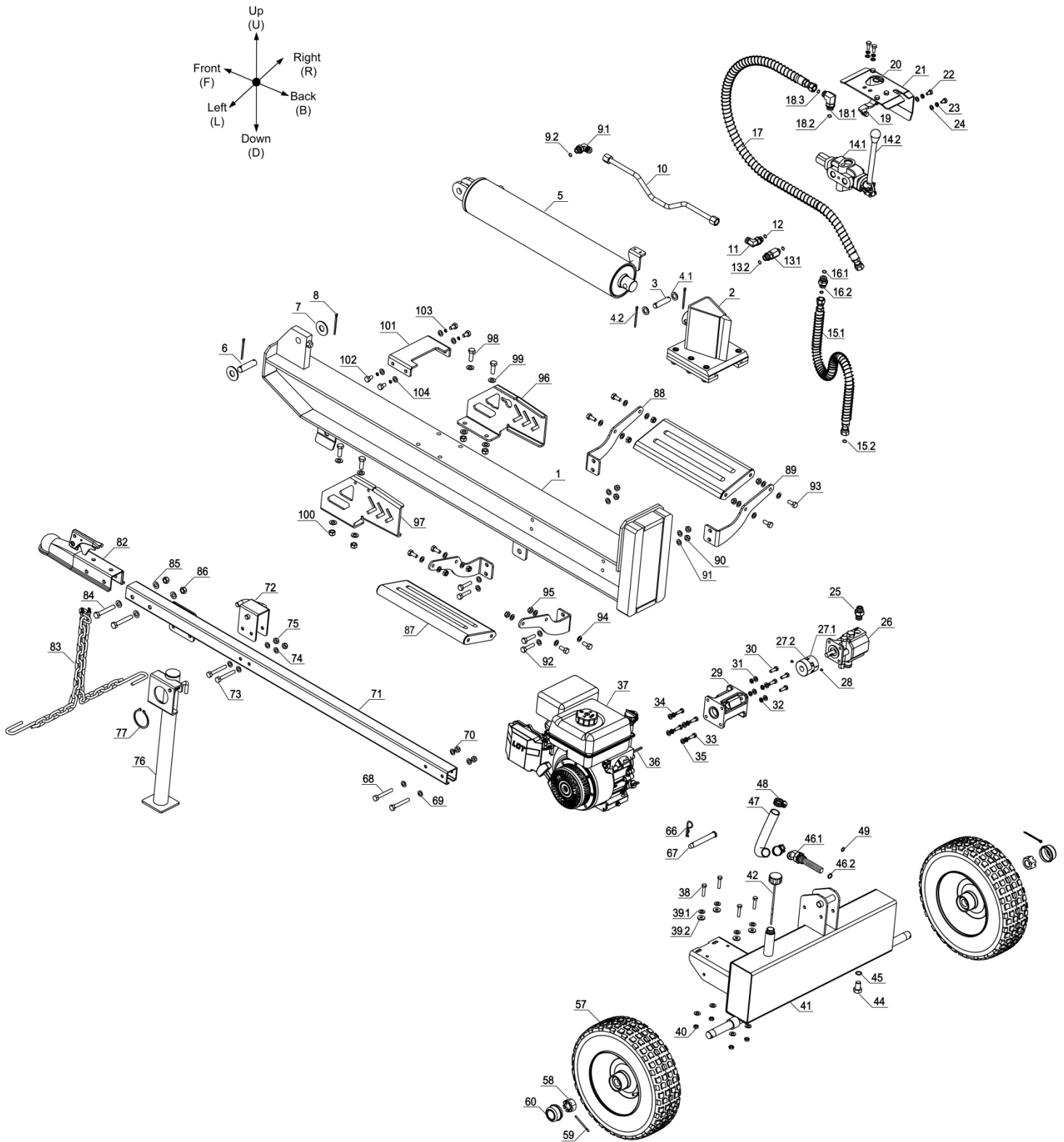





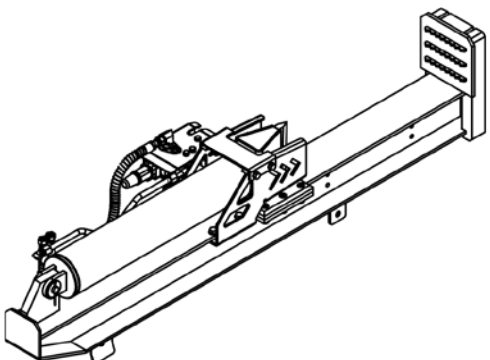
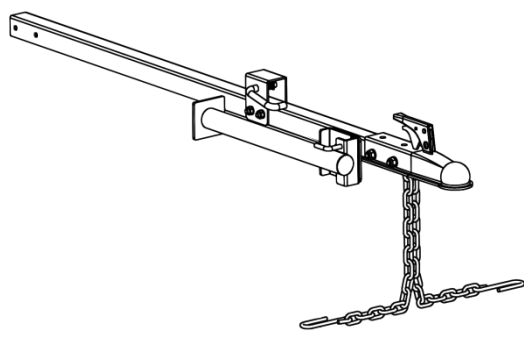
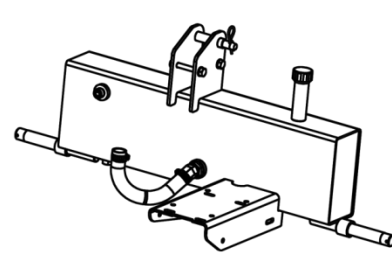
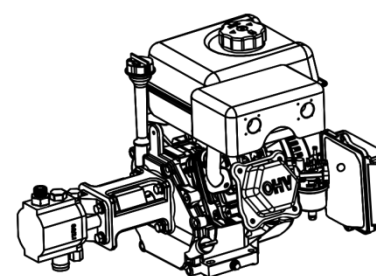
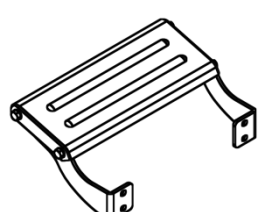

REF #	PART #	PART NAME	SPECIFICATIONS	QTY PER UNIT
	310-633	Beam incl. End Plate 22 Ton	10-10-8	
1	310-658	Beam incl. End Plate 25 Ton	10-10-10	1
	310-346	Beam incl. End Plate 28 / 30 Ton	10-12-10	
	310-471	Beam incl. End Plate 35 Ton	12-12-12	
2	530-421	Splitting Wedge w/ Guides 22-30 Ton	Guide12	1
	530-423	Splitting Wedge w/ Guides 35 Ton	Guide14	
3	760-118	Pin	PH, Ø16*69-Ø4.5	1
4.1	750-566	Flat Washer	PH, M16	2
4.2	760-734	Split Pin	ZP, Ø4*35	2
5	530-468	Cylinder 22 / 25 Ton	4.0 in. * 21.6in.	
	530-473	Cylinder 28 / 30 Ton	4.5 in. * 21.6in.	1
	530-485	Cylinder 35 Ton	5.0 in. * 21.6in.	
6	760-112	Pin	PH, Ø20*72-Ø3.5	1
7	750-423	Flat Washer	PH, M20	2
8	760-755	Split Pin	ZP, Ø3*40	2
9.1	560-356	Adapter	90 Degree, Hex19/ Hex24	1
9.2	730-077	O Seal Ring	Ø21*2.4	1
10	560-427	Hydraulic Hose for A-Capacity		1
11	510-356	Hydraulic Adaptor for A-Capacity	90 Degree, Hex19/ Hex24	1
12	730-077	O Seal Ring	Ø21*2.4	1
13.1	510-464	Hydraulic Adaptor for B-Capacity	Straight, Hex27*43	1
13.2	730-077	O Seal Ring	Ø21*2.4	2
14.1	520-799	Hydraulic Valve		1
14.2	520-452	Control Handle	Ø15*220, Ball Grip	1
15.1	560-454	Connecting Hydraulic Hose w/ Protection Spring	½"*900	1
15.2	730-619	O Seal Ring	Ø15*1.9	1
16.1	730-088	O Seal Ring	Ø24*2.4	2
16.2	510-448	Hydraulic Adapter on Valve for Connecting Hose	Straight, Hex27*36.5	1
17	560-523	Oil Return Hose w/ Protection Spring	1/2"*1400	1
18.1	510-469	Hydraulic Adapter	90 Degree, Hex27, 1/2"hose	1
18.2	730-088	O Seal Ring	Ø24*2.4	1
18.3	730-619	O Seal Ring	Ø15*1.9	1
19	520-532	Handle Release Lever	WD	1
20	520-578	Extension Spring	Ø8*53	1
21	350-224	Valve Cover	WD	1
22	710-637	Hex Head Bolt	ZP, M8*20 (8.8)	4
23	750-834	Spring Washer	ZP, M8	4
24	750-638	Flat Washer	ZP, M8	4
25	510-432	Hydraulic Adapter on Pump for Connecting Hose	Straight, Hex27*45	1
26	550-412	Two Stage Pump	11gpm (22/ 25 / 28T)	1
	550-533	Two Stage Pump	16gpm (30 / 35T)	
27.1	550-702	Coupling Shaft	3/4" (22/28T)	1
	550-703	Coupling Shaft	1" (30 /35T)	
27.2	550-706	Coupling Spider		1
28	740-600	Set Screw	Black Oxide, M6*10	2
29	550-814	Pump Mount	Al, 22/ 25 / 28T	1
	550-817	Pump Mount	Al, 30 / 35T	
30	710-637	Hex Head Bolt	ZP, M8*20 (8.8)	4
31	750-638	Flat Washer	ZP, M8	4
32	750-834	Spring Washer	ZP, M8	4
33	710-632	Hex Head Bolt	ZP, 5/16-24*20 (8.8)	4

REF #	PART #	PART NAME	SPECIFICATIONS	QTY PER UNIT
34	750-617	Flat Washer	ZP, 5/16	4
35	750-844	Spring Washer	ZP, 5/16	4
36	770-123	Engine Shaft Square Key	3/16 X 1.75 (22/25/28T)	1
	770-125	Engine Shaft Square Key	1/4 X 2.165 (30/35T)	
37	960-110	Gas Engine (BI75)	22T	1
	960-327	Gas Engine (Kohler 6.5)	25/28T	
	960-390	Gas Engine (Kohler 9.5)	30/35T	
38	710-693	Hex Head Bolt	ZP, M8*40 (22//25/28T)	4
	710-553	Hex Head Bolt	ZP, M10*40(30/35T)	
39.1	750-638	Flat Washer	ZP, M8 (22/25/28T)	8
	750-525	Flat Washer	ZP, M10 (30/35T)	
39.2	960-429	Vibration Isolator 22/25/28 Ton	Ø24*Ø9*3	4
	960-430	Vibration Isolator 30/35 Ton	Ø24*Ø11*3	
40	720-500	Lock Nut	ZP, M8 (22/ 25/28T)	4
	720-120	Lock Nut	ZP, M10 (30/35T)	
41	540-524	Reservoir Tank	WD22/25/28T	1
	540-931	Reservoir Tank	WD30T	
	540-958	Reservoir Tank	WD35T	
42	540-329	Vented Dipstick	Ø4.35*186	1
44	710-877	Oil Drain Screw	PH, M16*15	1
45	730-064	O Seal Ring	Ø20*2.4	1
46.1	540-049	Suction filter	45 Degree Adapter, Hex32	1
46.2	730-122	O Seal Ring	Ø30*3.1	1
47	560-342	Oil Suction Hose	Ø24*300,Curved	1
48	760-377	Hose Clamp	1"	2
49	730-619	O Seal Ring	Ø15*1.9	1
57	330-524	Wheel	Pneumatic, 16*4.8*8 in.	2
58	720-836	Castle Nut	ZP, 1-14	2
59	760-744	Split Pin	ZP, Ø4*50	2
60	330-631	Dust Cap		2
66	760-679	Spring Clip	ZP, Ø3	1
67	760-254	Clevis Pin	ZP, Ø15.5*120	1
68	710-580	Hex Head Bolt	ZP, M10*75 (8.8)	2
69	750-525	Flat Washer	ZP, M10	4
70	720-120	Lock Nut	ZP, M10	2
71	320-443	Tongue	WD	1
72	320-845	Horizontal Beam Lock	WD	1
73	710-568	Hex Head Bolt	ZP, M10*70 (8.8)	2
74	750-525	Flat Washer	ZP, M10	4
75	720-120	Lock Nut	ZP, M10	2
76	320-806	Flip-down Stand		1
77	760-522	Circlip	Ø58	1
82	320-420	Hitch Coupler	2"*2"	1
83	320-421	Safety Chain		2
84	710-433	Hex Head Bolt	ZP, M12*75 (8.8)	2
85	750-621	Flat Washer	ZP, M12	4
86	720-536	Lock Nut	ZP, M12	2
87	320-942	Log Tray Plate	WD	2
88	320-940	Log Tray Frame (FR, BL)	WD	2

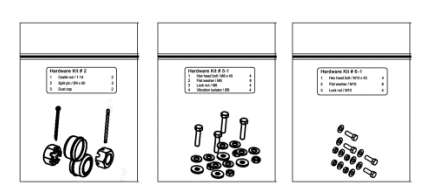
REF #	PART #	PART NAME	SPECIFICATIONS	QTY PER UNIT
89	320-948	Log Tray Frame (FL, BR)	WD	2
90	720-120	Lock Nut	ZP, M10	4
91	750-525	Flat Washer	ZP, M10	8
92	710-556	Hex Head Bolt	ZP, M10*45 (8.8)	4
93	710-520	Hex Head Bolt	ZP, M10*25 (8.8)	8
94	750-525	Flat Washer	ZP, M10	16
95	720-120	Lock Nut	ZP, M10	8
96	320-926	Log Dislodger (R)		1
97	320-927	Log Dislodger (L)		1
98	710-511	Hex Head Bolt	ZP, M12*45 (8.8)	4
99	750-621	Flat Washer	ZP, M12	8
100	720-536	Lock Nut	ZP, M12	4
101	320-949	Dislodger Top Plate		1
102	710-516	Hex Head Bolt	ZP, M10*20	4
103	750-401	Spring Washer	ZP, M10	4
104	750-525	Flat Washer	ZP, M10	4

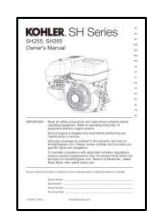
# PACKING LIST

			
<p align="center"><b>Beam assembly x 1</b></p>	<p align="center"><b>Tongue assembly x 1</b></p>		
			
<p align="center"><b>Reservoir tank assembly x 1</b></p>	<p align="center"><b>Engine / Pump assembly x 1</b></p>		
			
<p align="center"><b>Log tray assembly x 2</b></p>	<p align="center"><b>Wheel x 2</b></p>		
			
<p align="center"><b>Hardware kit # 2, 5, 6-1</b></p>	<p align="center"><b>Instruction manual x 1</b></p>	<p align="center"><b>Engine manual x 1</b></p>	<p align="center"><b>Log splitter cover</b></p>
<p align="center"><b>Hardware kit box 1, including:</b></p>			

# WARRANTY

## LIMITED WARRANTY STATEMENT

Boss Industrial, Inc., ("Boss Industrial") warrants to the original retail purchaser that this BOSS brand outdoor product is free from defect in material and workmanship and agrees to repair or replace, at Boss Industrial's, discretion, any defective product free of charge within these time periods from the date of purchase under the limited warranty terms below.

- Two years for all models if used for personal, family, or household use;
- 180 days for any unit used for other purposes, such as rental or commercial.

This warranty extends to the original retail purchaser only and commences on the date of the original retail purchase. Any part of the this product manufactured or supplied by Boss Industrial and found in the reasonable judgment of Boss Industrial to be defective in material or workmanship will be repaired or replaced without charge for parts and labor by a Boss Industrial authorized service center. **How to process a warranty claim? You must first call the BOSS INDUSTRIAL service hotline 1 800 780 2677. Our technical team will guide you in trouble shooting, repairing, or returning a defective part or machine. Any unauthorized repair or return without a valid Authorization Number from Boss Industrial will invalidate this warranty.** The expense of delivering the replacement part or product to the dealer for warranty work and the expense of returning it back to the owner after repair or replacement will be paid by the owner. Boss Industrial's responsibility in respect to claims is limited to making the required repairs or replacements and no claim of breach of warranty shall be cause for cancellation or rescission of the contract of sale of any BOSS brand product. Proof of purchase will be required by the dealer to substantiate any warranty claim. All warranty work must be performed by a Boss Industrial authorized service center.

This warranty is limited to one hundred eighty (180) days from the date of original retail purchase for any Boss Industrial brand product that is used for rental or commercial purposes, or any other income-producing purpose.

**This warranty does not cover any BOSS brand product that has been subject to misuse, neglect, negligence, or accident, or that has been operated in any way contrary to the operating instructions as specified in this operator's manual. This warranty does not apply to any damage to the product that is the result of improper maintenance or to any product that has been altered or modified. The warranty does not extend to repairs made necessary by normal wear or by the use of parts or accessories which are either incompatible with the BOSS brand product or adversely affect its operation, performance, or durability. In addition, this warranty does not cover:**

- A. Tune-ups – Switch, Capacitor, Cable fastener, Spark Plugs, Carburetors, Adjustments, Ignition, Filters, Handles
- B. Wear items – Tires, nylon liners, rubber seals, hydraulic oil
- C. Gas Engines – as they are covered under the Engine Manufacturers' Warranty.

Boss Industrial reserves the right to change or improve the design of any BOSS brand product without assuming any obligation to modify any product previously manufactured.

ALL IMPLIED WARRANTIES ARE LIMITED IN DURATION TO THE STATED WARRANTY PERIOD. ACCORDINGLY, ANY SUCH IMPLIED WARRANTIES INCLUDING MERCHANTABILITY, FITNESS FOR A PARTICULAR PURPOSE, OR OTHERWISE, ARE DISCLAIMED IN THEIR ENTIRETY AFTER THE EXPIRATION OF THE APPROPRIATE TWO-YEAR, ONE-YEAR, OR NINETY-DAY WARRANTY PERIOD. BOSS INDUSTRIAL'S OBLIGATION UNDER THIS WARRANTY IS STRICTLY AND EXCLUSIVELY LIMITED TO THE REPAIR OR REPLACEMENT OF DEFECTIVE PARTS AND BOSS INDUSTRIAL DOES NOT ASSUME OR AUTHORIZE ANYONE TO ASSUME FOR THEM ANY OTHER OBLIGATION. SOME STATES DO NOT ALLOW LIMITATIONS ON HOW LONG AN IMPLIED WARRANTY LASTS, SO THE ABOVE LIMITATION MAY NOT APPLY TO YOU. BOSS INDUSTRIAL ASSUMES NO RESPONSIBILITY FOR INCIDENTAL, CONSEQUENTIAL, OR OTHER DAMAGES INCLUDING, BUT NOT LIMITED TO, EXPENSE OF RETURNING THE PRODUCT TO AN AUTHORIZED BOSS INDUSTRIAL SERVICE CENTER AND EXPENSE OF DELIVERING IT BACK TO THE OWNER, MECHANIC'S TRAVEL TIME, TELEPHONE OR TELEGRAM CHARGES, RENTAL OF A LIKE PRODUCT DURING THE TIME WARRANTY SERVICE IS BEING PERFORMED, TRAVEL, LOSS OR DAMAGE TO PERSONAL PROPERTY, LOSS OF REVENUE, LOSS OF USE OF THE PRODUCT, LOSS OF TIME, OR INCONVENIENCE. SOME STATES DO NOT ALLOW THE EXCLUSION OR LIMITATION OF INCIDENTAL OR CONSEQUENTIAL DAMAGES, SO THE ABOVE LIMITATION OR EXCLUSION MAY NOT APPLY TO YOU.

This warranty gives you specific legal rights, and you may also have other rights which vary from state to state. This warranty applies to all BOSS brand products manufactured by or for Boss Industrial and sold in the United States.



**Boss Industrial, Inc. • 5 Earl Court, Unit 120**

Woodridge, IL 60517 • USA

Phone: (800) 780-BOSS (2677) • Fax (331) 472-2976

[www.boss-industrial.com](http://www.boss-industrial.com)