

A4

GeekChef® PORTABLE GAS GRILL

Instruction Manual
MODEL NO.: HIBC1702-01
ITEM NO.: GPG1702

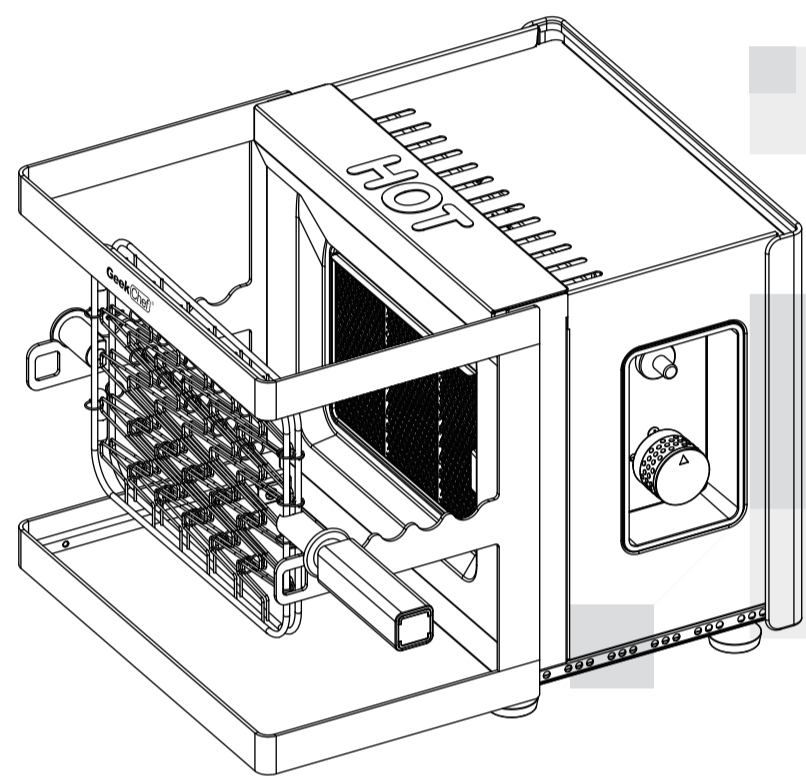

Toll Free: 1-844-801-8880
IMPORTANT: Read the instructions carefully before operating the appliance and keep them for future reference.

Table of Contents

Technical Characteristics	3
General Safety Information	3
General Installation	3
Portable L.P. Gas Cylinder	4
Grill Features	4
Assemble Grill	5
Rotisserie Grill Basket Use Instructions	6
Connecting/Disconnecting the Gas Cartridge to the Appliance	6
Installing 1 lb. Propane Cylinder	6
Leak testing-Disposable L.P. Gas Cylinders	7
How to Check for Leaks	7
Fixing A Fuel Leak	7
Regulator and Hose	7
Start-Up Check List	7
Lighting Instructions	7
Lighting The Burner	7
Shutting Off the Grill	7
General Use and Correct Burner Flames	7
The Burner Flame Check	8
Grilling Tips and Hints	8
In Case of Grease Fire	8
Care, Maintenance and Cleaning	8
Moving and Storage	8
Troubleshooting	8
Limited Warranty	9

Assembly Instructions

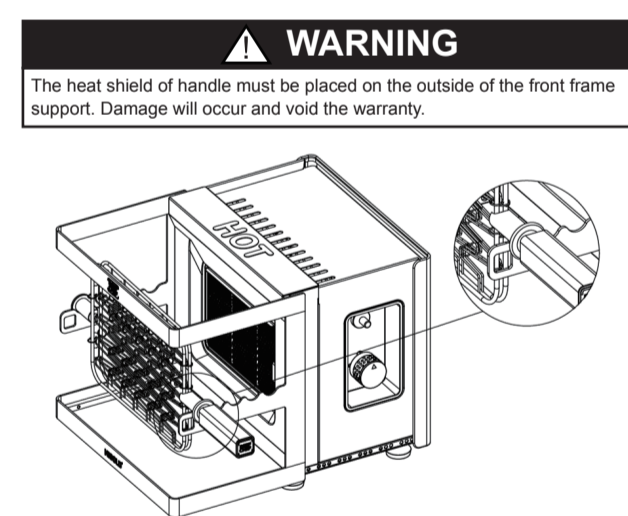

Rotisserie Grill Basket Use Instructions
Locking – side clamp

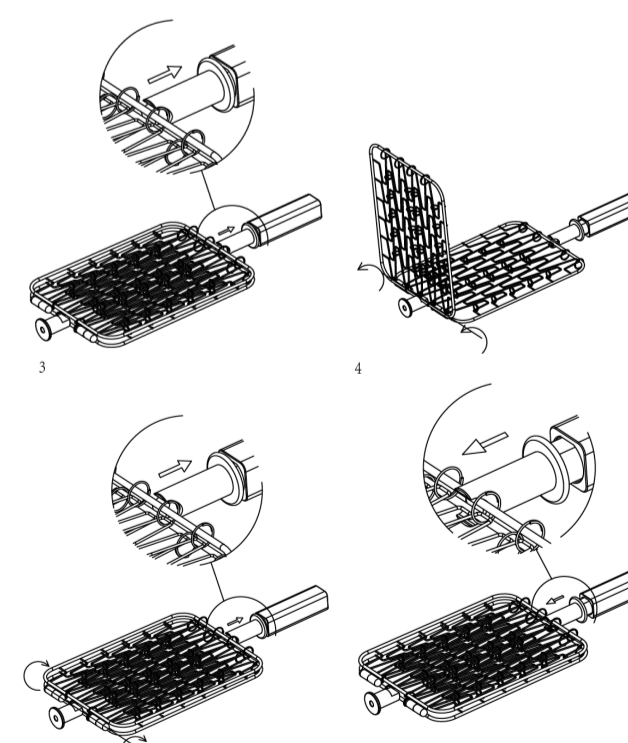

CAUTION
You must USE protective gloves when operating the hot locking side clamp of the grill to prevent burn.
– Notice the “Tap” sign on the handle of the locking side clamp.

Connecting/Disconnecting the Gas Cartridge to the Appliance

WARNING
Only cylinders marked “Propane” must be used. Only use a 1 lb. disposable propane cylinder.

WARNING
The propane MUST be performed outdoors only. Read and follow the directions on the cylinder.
Before attaching propane cylinder make sure burner valve is in the OFF position.
Remove plastic cap from top of propane cylinder and screw cylinder into regulator hand tight.
Never operate grill with propane cylinder in an inverted position.

DANGER
NEVER store a spare L.P. gas supply cylinder under the grill body or in the vicinity of any heat producing appliance.
Failure to follow this information exactly could result in an explosion and/or fire causing death or serious injury.

CAUTION
Tighten by hand only. DO NOT use tools.

Installing 1 lb. Propane Cylinder

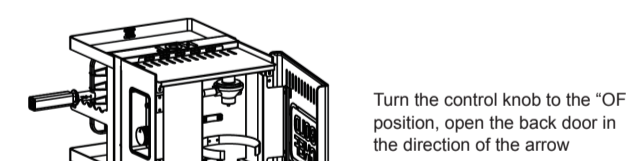

Turn the control knob to the “OFF” position, open the back door in the direction of the arrow.



Turn gas cartridge clockwise to connect the gas regulator.

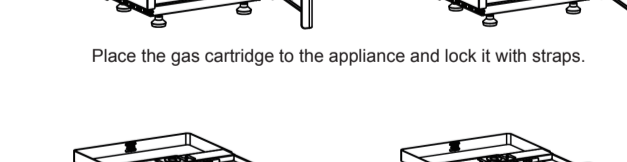

Place the gas cartridge to the appliance and lock it with straps.

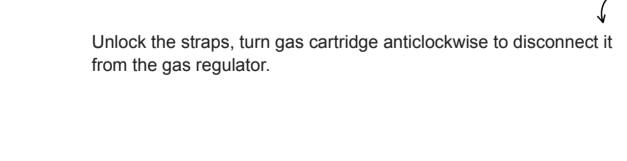

Unlock the straps, turn gas cartridge anticlockwise to disconnect it from the gas regulator.

Leak Testing- Disposable L.P. Gas Cylinders

DANGER
TO PREVENT FIRE OR EXPLOSION HAZARD:
– NO SMOKING. DO NOT use or permit sources of ignition in the area while doing a leak test.
– Perform leak tests outdoors only.
– NEVER perform a leak test with fire flame.

How to Check for Leaks

1. Make a soapy solution of equal parts mild liquid dishwashing detergent and water.
2. Turn off the burner control knob.
3. Apply a soapy solution to the connection. If bubbles appear in these areas, a leak is indicated.

No Smoking

Fixing A Fuel Leak

If you detect a leak:
1. Stop a leak by tightening the loose joint. DO NOT attempt to repair the cylinder. If it should become damaged, the cylinder MUST be replaced.
2. If you are unable to stop a leak, remove the cylinder from the grill. DO NOT use the grill until the leak is corrected.

Regulator and Hose

Use only regulators and hoses approved for LPG at the above pressure 30 inbar. The life expectancy of the regulator is estimated as 10 years, it is recommended that the regulator is changed within 10 years of the date of manufacture. Please check production date on your instructions.
The use of the wrong regulator or hose is unsafe, always check that you have the correct items before operating.
The hose and regulator used must conform to the relevant standard for the country of use. The length of the hose must be 2.0m maximum. When or damaged hoses must be replaced. Ensure that the hose is not obstructed, twisted, or in contact with any part of the rotisserie grill other than its connection.

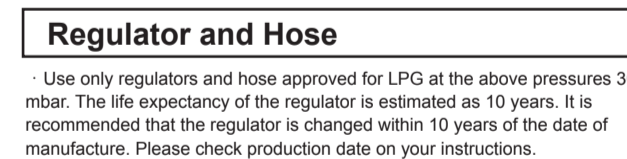

Regulator seals



Turn the burner control knob to off.

Start-Up Check List

WARNING
Do NOT use charcoal or lighting fuel.
Do NOT attempt to fill any 1 lb. disposable fuel cylinders. Use only the gas specified.
Operate the grill on horizontal solid surface only.

Lighting Instructions

WARNING
THE FOLLOWING RULES MUST ALWAYS BE FOLLOWED IN THIS ORDER:
1. Check that the burner control knob is turned to “OFF”.
2. DO NOT stand with your head or arms over the cooking area.

Lighting The Burner

Infrared Ray Piezoelectric Igniter:
1. Turn control knob to the “OFF” position.
2. Connect the gas cartridge to the grill as the instructions.
3. To light the burner, push down and turn the burner control knob to 9 o'clock position, wait maximum 5 seconds and press the red piezoelectric igniter button once. Repeat the control knob pushed for further 5-20 seconds until the burner starts to glow.

Fixing A Fuel Leak

If you detect a leak:
1. Stop a leak by tightening the loose joint. DO NOT attempt to repair the cylinder. If it should become damaged, the cylinder MUST be replaced.
2. If you are unable to stop a leak, remove the cylinder from the grill. DO NOT use the grill until the leak is corrected.

Regulator and Hose

Use only regulators and hoses approved for LPG at the above pressure 30 inbar. The life expectancy of the regulator is estimated as 10 years, it is recommended that the regulator is changed within 10 years of the date of manufacture. Please check production date on your instructions.
The use of the wrong regulator or hose is unsafe, always check that you have the correct items before operating.
The hose and regulator used must conform to the relevant standard for the country of use. The length of the hose must be 2.0m maximum. When or damaged hoses must be replaced. Ensure that the hose is not obstructed, twisted, or in contact with any part of the rotisserie grill other than its connection.



Regulator seals

Turn the burner control knob to off.

Start-Up Check List

WARNING
Do NOT use charcoal or lighting fuel.
Do NOT attempt to fill any 1 lb. disposable fuel cylinders. Use only the gas specified.
Operate the grill on horizontal solid surface only.

General Use and Correct Burner Flames

WARNING
Keep the grill area clear and free from combustible materials, gasoline and other flammable vapors, liquids, and spare L.P. cylinders.
DO NOT obstruct the flow of combustion and ventilation air.
Keep the ventilation opening(s) of the L.P. cylinder enclosure free and clear of debris.
A grill becomes hot during use. DO NOT touch cooking surfaces or heat shield.

Care, Maintenance and Cleaning

Operation Instructions

The Burner Flame Check

Observe whether there is a flame out of the burner, no flame spot, the burner turns red, prove the burner normal operation. Otherwise it is not normal.
Keep your arms and face away from being directly above the cooking area. Look through the cooking grates and observe the burner's flame. Some white film on burners up to 1 inch in length are acceptable as long as no carbon or soot deposits appear.
Regulate air of your grill will actually help keep it operating more smoothly to the burner and back of the grill. The flavor of grilled food will improve the more you use the grill and air become familiar with it.

Grilling Tips and Hints

Burner Control Setting Tips:
– The high flame setting is good for quick searing of meat, then finish cooking on a medium flame setting.
– Use a medium flame setting for cooking of steaks, pork chops, chicken and hamburgers.
– Use a low flame setting for roasts.
– These roasts will finish with a better texture and more juice if first seared on high flame setting and then cooked on a low flame setting.

Safe Grill Operation

NEVER leave cooking food unattended. Continuously observing the food will help in maintaining an even temperature, conserve fuel, improve the foods flavor and lessen flare-ups.
To avoid the grill basket, slowly lift the handle to avoid burning in case of a grease fire flare-ups.
DO NOT expose any part of your body directly above the cooking area.

Food Preparation Hints

Your grill can cook a variety of foods. For best results, follow these instructions:
– Thin steaks, fat from meat and poultry. Steak any remaining fat to stop curling, but skin care not to cut the meat.
– Frozen meat and poultry should be thawed prior to cooking.
– Frozen fish and vegetables will cook without thawing.
– Salt food after cooking to help prevent drying out the food.
– Brush naturally lean meats with cooking oil or margarine.
– Cook small pieces of tender foods in foil or on special delicate food cooking grate/pane the section titled “Cooking Methods”.
– Apply barbecue, tomato or sugar based sauces no sooner than the last 10 minutes of cooking.
– Turn food with tongs or a spatula, piercing food/spacer meat, tends to dry it out.

In Case of Grease Fire

Follow These Steps:
1. Shut off the gas at the burner valve and stay away!
2. Allow the fire to burn itself out.
3. Once the fire is out and the appliance has cooled, remove the disposable cylinder.
4. Clean all parts and inspect for damage. Parts to check for damage are the L.P. cylinder, regulator, burner valve, and the burner.
5. DO NOT obstruct the flow of combustion and ventilation air.
6. Check before operating grill again. Do not replace any component by yourself.

General Use and Correct Burner Flames

WARNING
Keep the grill area clear and free from combustible materials, gasoline and other flammable vapors, liquids, and spare L.P. cylinders.
DO NOT obstruct the flow of combustion and ventilation air.
Keep the ventilation opening(s) of the L.P. cylinder enclosure free and clear of debris.
A grill becomes hot during use. DO NOT touch cooking surfaces or heat shield.

Care, Maintenance and Cleaning

WARNING
This appliance is not to be installed in or on a recreational vehicle and/or boat.

ASSEMBLER/INSTALLER
Leave these instructions with the consumer.

CONSUMER/USER:
Read all instructions and keep in a safe place for future reference.

For Outdoor Use Only
Note: Propane cylinder is not included.

Technical Characteristics
Input Rating: 1 burner, 12,000 BTU/h
Category: Pressure regulated propane
Fuel: 16.4 oz disposable propane cylinder

General Safety Information
This manual contains important information about the assembly, operation and maintenance of the outdoor propane appliance. General safety information is presented on this page and is also located throughout these instructions. Particular attention should be paid to information accompanied by the safety alert symbols.

CAUTION: **WARNING:** **DANGER:**

Keep this manual for future reference and to educate new users of this product. This manual should be read in conjunction with the labeling on the product.

Safety precautions are essential when any mechanical or propane fueled equipment is involved. These precautions are necessary when using, storing, and servicing. Using this equipment with the respect and caution demanded will reduce the possibilities of personal injury or property damage.

The following symbols shown below are used extensively throughout these instructions. Always heed these precautions as they are essential when using any mechanical or propane fueled equipment.

WARNING
If you smell gas:
1. Shut off gas to the appliance.
2. Extinguish any open flame.
3. If odor continues, keep away from the appliance and immediately call your gas supplier or your fire department.

WARNING
1. Do not store or use gasoline or other flammable liquids or vapors in the vicinity of this or any other appliance.
2. An L.P. cylinder not connected for use shall not be stored in the vicinity of this or any other appliance.

CAUTION
1. Do not store or use gasoline or other flammable liquids or vapors in the vicinity of this or any other appliance.
2. An L.P. cylinder not connected for use shall not be stored in the vicinity of this or any other appliance.

WARNING
FOR OUTDOOR USE ONLY: NEVER operate grill in enclosed areas, as this could lead to gas accumulating from a leak, causing an explosion or a carbon monoxide buildup, which could result in injury or death. DO NOT use in garages, breezeways, porches or any enclosed area.
DO NOT FOR USE BY CHILDREN.
If these instructions are ignored, a hazardous fire or explosion could result in personal injury, death or property damage!

WARNING
DO NOT move grill while it is lit.
Keep outdoor cooking gas appliance area clear and free from combustible materials, gasoline, and other flammable vapors and liquids.

WARNING
DO NOT lean on the grill.
NEVER use charcoal ignition or lighter fluid in a gas grill.
Grill is hot when in use, to avoid burns, DO NOT touch any hot grill surface. Keep children and pets away from the grill.
NEVER leave the grill unattended while it is in use.
It is your responsibility to assemble, install, operate and care for your gas grill properly.
DO NOT use gas grill indoors.
Under some circumstances, propane may lose the distinctive odor that was added. Other strong odors may hide or mask the odor of propane. Colds, allergies, sinus congestion, and the use of tobacco, alcohol or drugs may impair your ability to detect the odor of propane.

General Installation
Installation must conform with local codes or in the absence of local codes, with the National Fuel Gas Code, ANSI Z223.1/NFPA 54, National Gas and Propane Installation Code, CSA B149.1, or Propane Storage and Handling Code, CSA B149.2, as applicable. To check local codes, see your local L.P. gas dealer or natural gas company listed in the Yellow Pages for recommended installation procedures and regulations.

DANGER
DANGER indicates an imminently hazardous situation which, if not avoided, will result in death or serious injury.

WARNING
WARNING indicates a potentially hazardous situation which, if not avoided, could result in death or serious injury.

CAUTION
CAUTION indicates a potentially hazardous situation which, if not avoided, could result in minor or moderate personal injury, or property damage.

WARNING
If you smell gas:
1. Shut off gas to the appliance.
2. Extinguish any open flame.
3. If odor continues, keep away from the appliance and immediately call your gas supplier or your fire department.

WARNING
1. Do not store or use gasoline or other flammable liquids or vapors in the vicinity of this or any other appliance.
2. An L.P. cylinder not connected for use shall not be stored in the vicinity of this or any other appliance.

CAUTION
1. Do not store or use gasoline or other flammable liquids or vapors in the vicinity of this or any other appliance.
2. An L.P. cylinder not connected for use shall not be stored in the vicinity of this or any other appliance.

WARNING
FOR OUTDOOR USE ONLY: NEVER operate grill in enclosed areas, as this could lead to gas accumulating from a leak, causing an explosion or a carbon monoxide buildup, which could result in injury or death. DO NOT use in garages, breezeways, porches or any enclosed area.
DO NOT FOR USE BY CHILDREN.
If these instructions are ignored, a hazardous fire or explosion could result in personal injury, death or property damage!

WARNING
DO NOT move grill while it is lit.
Keep outdoor cooking gas appliance area clear and free from combustible materials, gasoline, and other flammable vapors and liquids.

WARNING
DO NOT lean on the grill.
NEVER use charcoal ignition or lighter fluid in a gas grill.
Grill is hot when in use, to avoid burns, DO NOT touch any hot grill surface. Keep children and pets away from the grill.
NEVER leave the grill unattended while it is in use.
It is your responsibility to assemble, install, operate and care for your gas grill properly.
DO NOT use gas grill indoors.
Under some circumstances, propane may lose the distinctive odor that was added. Other strong odors may hide or mask the odor of propane. Colds, allergies, sinus congestion, and the use of tobacco, alcohol or drugs may impair your ability to detect the odor of propane.

General Installation
Installation must conform with local codes or in the absence of local codes, with the National Fuel Gas Code, ANSI Z223.1/NFPA 54, National Gas and Propane Installation Code, CSA B149.1, or Propane Storage and Handling Code, CSA B149.2, as applicable. To check local codes, see your local L.P. gas dealer or natural gas company listed in the Yellow Pages for recommended installation procedures and regulations.

Safety Instructions

WARNING
This appliance is not to be installed in or on a recreational vehicle and/or boat.

Follow these safety rules before each use:
1. A minimum clearance of 24 inches from the grill. Each side of the grill must be maintained between the grill and any combustible construction such as wood siding of a building.
2. Never locate the grill under an unprotected combustible material or overhead.
3. Do not obstruct the flow of combustion and ventilation air. Maintain a minimum clearance of 3 inches from the back of the grill and non-combustible construction such as a concrete or brick wall.
4. The grill should be level and not facing directly into the wind.

WARNING
A liquid propane tank, not connected for use with this gas grill, shall not be stored in the vicinity of this or any other appliance.
Connections must comply with local requirements and are the sole responsibility of the person performing the work.

WARNING
DO NOT attempt to adjust the regulator as this could create a situation causing personal injury or property damage.

WARNING
1. Do not store or use gasoline or other flammable liquids or vapors in the vicinity of this or any other appliance.
2. An L.P. cylinder not connected for use shall not be stored in the vicinity of this or any other appliance.

WARNING
FOR OUTDOOR USE ONLY: NEVER operate grill in enclosed areas, as this could lead to gas accumulating from a leak, causing an explosion or a carbon monoxide buildup, which could result in injury or death. DO NOT use in garages, breezeways, porches or any enclosed area.
DO NOT FOR USE BY CHILDREN.
If these instructions are ignored, a hazardous fire or explosion could result in personal injury, death or property damage!

WARNING
DO NOT move grill while it is lit.
Keep outdoor cooking gas appliance area clear and free from combustible materials, gasoline, and other flammable vapors and liquids.

WARNING
DO NOT lean on the grill.
NEVER use charcoal ignition or lighter fluid in a gas grill.
Grill is hot when in use, to avoid burns, DO NOT touch any hot grill surface. Keep children and pets away from the grill.
NEVER leave the grill unattended while it is in use.
It is your responsibility to assemble, install, operate and care for your gas grill properly.
DO NOT use gas grill indoors.
Under some circumstances, propane may lose the distinctive odor that was added. Other strong odors may hide or mask the odor of propane. Colds, allergies, sinus congestion, and the use of tobacco, alcohol or drugs may impair your ability to detect the odor of propane.

General Installation
Installation must conform with local codes or in the absence of local codes, with the National Fuel Gas Code, ANSI Z223.1/NFPA 54, National Gas and Propane Installation Code, CSA B149.1, or Propane Storage and Handling Code, CSA B149.2, as applicable. To check local codes, see your local L.P. gas dealer or natural gas company listed in the Yellow Pages for recommended installation procedures and regulations.

Grill Features

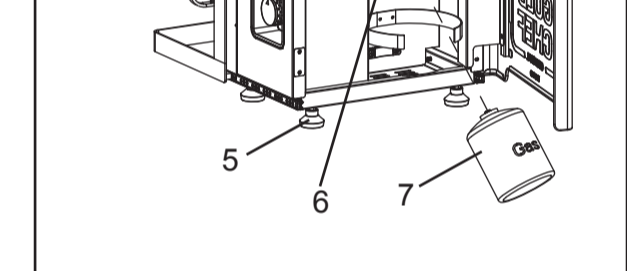

1. Grilling/Cooking Surface
2. Piezoelectric Igniter
3. Control Knob
4. Grill Basket
5. Foot
6. Regulator
7. Disposable Cylinder (Not Included)
8. Drip Tray

Portable L.P. Gas Cylinder

Liquefied Petroleum gas (abbreviated L.P. gas propane), is highly flammable. It becomes liquid when stored under high pressure inside a cylinder and vapors when released. L.P. gas is heavier than air and tends to collect in the area. It is important that there are no leaking connections on your gas grill that could cause a fire or explosion (see the section titled “LEAK TEST”).

Portable L.P. gas grills require a fuel delivery system which is comprised of a valve, a regulator with vent hose and an L.P. gas supply cylinder.

Cylinder Specifications
All L.P. gas cylinders used with this appliance shall be constructed and inspected in accordance with the Specifications for L.P. Gas Cylinders of the U.S. Department of Transportation (DOT) or the National Standard of Canada, CANCSA-B328 Cylinders, Spheres and Tubes for Transportation of Dangerous Goods, and Commission, as applicable, and a secure connection device compatible with the connection for outdoor cooking appliances.
Read labels on the L.P. Gas Supply Cylinder.

WARNING
NEVER store a spare L.P. gas supply cylinder under the grill body or inside the grill enclosure or in the vicinity of any heat producing appliance. Failure to follow this information exactly could result in an explosion and/or fire causing death or serious injury.

WARNING
NEVER store a spare L.P. gas supply cylinder under the grill body or inside the grill enclosure or in the vicinity of any heat producing appliance. Failure to follow this information exactly could result in an explosion and/or fire causing death or serious injury.

WARNING
NEVER store a spare L.P. gas supply cylinder under the grill body or inside the grill enclosure or in the vicinity of any heat producing appliance. Failure to follow this information exactly could result in an explosion and/or fire causing death or serious injury.

WARNING
NEVER store a spare L.P. gas supply cylinder under the grill body or inside the grill enclosure or in the vicinity of any heat producing appliance. Failure to follow this information exactly could result in an explosion and/or fire causing death or serious injury.

WARNING
NEVER store a spare L.P. gas supply cylinder under the grill body or inside the grill enclosure or in the vicinity of any heat producing appliance. Failure to follow this information exactly could result in an explosion and/or fire causing death or serious injury.

WARNING
NEVER store a spare L.P. gas supply cylinder under the grill body or inside the grill enclosure or in the vicinity of any heat producing appliance. Failure to follow this information exactly could result in an explosion and/or fire causing death or serious injury.

WARNING
NEVER store a spare L.P. gas supply cylinder under the grill body or inside the grill enclosure or in the vicinity of any heat producing appliance. Failure to follow this information exactly could result in an explosion and/or fire causing death or serious injury.

WARNING
NEVER store a spare L.P. gas supply cylinder under the grill body or inside the grill enclosure or in the vicinity of any heat producing appliance. Failure to follow this information exactly could result in an explosion and/or fire causing death or serious injury.

WARNING
NEVER store a spare L.P. gas supply cylinder under the grill body or inside the grill enclosure or in the vicinity of any heat producing appliance. Failure to follow this information exactly could result in an explosion and/or fire causing death or serious injury.

WARNING
NEVER store a spare L.P. gas supply cylinder under the grill body or inside the grill enclosure or in the vicinity of any heat producing appliance. Failure to follow this information exactly could result in an explosion and/or fire causing death or serious injury.

WARNING
NEVER store a spare L.P. gas supply cylinder under the grill body or inside the grill enclosure or in the vicinity of any heat producing appliance. Failure to follow this information exactly could result in an explosion and/or fire causing death or serious injury.

WARNING
NEVER store a spare L.P. gas supply cylinder under the grill body or inside the grill enclosure or in the vicinity of any heat producing appliance. Failure to follow this information exactly could result in an explosion and/or fire causing death or serious injury.

WARNING
NEVER store a spare L.P. gas supply cylinder under the grill body or inside the grill enclosure or in the vicinity of any heat producing appliance. Failure to follow this information exactly could result in an explosion and/or fire causing death or serious injury.

WARNING
NEVER store a spare L.P. gas supply cylinder under the grill body or inside the grill enclosure or in the vicinity of any heat producing appliance. Failure to follow this information exactly could result in an explosion and/or fire causing death or serious injury.

WARNING
NEVER store a spare L.P. gas supply cylinder under the grill body or inside the grill enclosure or in the vicinity of any heat producing appliance. Failure to follow this information exactly could result in an explosion and/or fire causing death or serious injury.

WARNING
NEVER store a spare L.P. gas supply cylinder under the grill body or inside the grill enclosure or in the vicinity of any heat producing appliance. Failure to follow this information exactly could result in an explosion and/or fire causing death or serious injury.

WARNING
NEVER store a spare L.P. gas supply cylinder under the grill body or inside the grill enclosure or in the vicinity of any heat producing appliance. Failure to follow this information exactly could result in an explosion and/or fire causing death or serious injury.

WARNING
NEVER store a spare L.P. gas supply cylinder under the grill body or inside the grill enclosure or in the vicinity of any heat producing appliance. Failure to follow this information exactly could result in an explosion and/or fire causing death or serious injury.

WARNING
NEVER store a spare L.P. gas supply cylinder under the grill body or inside the grill enclosure or in the vicinity of any heat producing appliance. Failure to follow this information exactly could result in an explosion and/or fire causing death or serious injury.

WARNING
NEVER store a spare L.P. gas supply cylinder under the grill body or inside the grill enclosure or in the vicinity of any heat producing appliance. Failure to follow this information exactly could result in an explosion and/or fire causing death or serious injury.

WARNING
NEVER store a spare L.P. gas supply cylinder under the grill body or inside the grill enclosure or in the vicinity of any heat producing appliance. Failure to follow this information exactly could result in an explosion and/or fire causing death or serious injury.

WARNING
NEVER store a spare L.P. gas supply cylinder under the grill body or inside the grill enclosure or in the vicinity of any heat producing appliance. Failure to follow this information exactly could result in an explosion and/or fire causing death or serious injury.

Safety Instructions

Assemble Grill

IMPORTANT: Remove all packing material prior to assembly/use.
Inspect all packing and remove all parts.
See carton for parts included with your unit.

WARNING
NEVER store a spare L.P. gas supply cylinder under the grill body or inside the grill enclosure or in the vicinity of any heat producing appliance. Failure to follow this information exactly could result in an explosion and/or fire causing death or serious injury.

WARNING
NEVER store a spare L.P. gas supply cylinder under the grill body or inside the grill enclosure or in the vicinity of any heat producing appliance. Failure to follow this information exactly could result in an explosion and/or fire causing death or serious injury.

WARNING
NEVER store a spare L.P. gas supply cylinder under the grill body or inside the grill enclosure or in the vicinity of any heat producing appliance. Failure to follow this information exactly could result in an explosion and/or fire causing death or serious injury.

WARNING
NEVER store a spare L.P. gas supply cylinder under the grill body or inside the grill enclosure or in the vicinity of any heat producing appliance. Failure to follow this information exactly could result in an explosion and/or fire causing death or serious injury.

WARNING
NEVER store a spare L.P. gas supply cylinder under the grill body or inside the grill enclosure or in the vicinity of any heat producing appliance. Failure to follow this information exactly could result in an explosion and/or fire causing death or serious injury.

WARNING
NEVER store a spare L.P. gas supply cylinder under the grill body or inside the grill enclosure or in the vicinity of any heat producing appliance. Failure to follow this information exactly could result in an explosion and/or fire causing death or serious injury.

WARNING
NEVER store a spare L.P. gas supply cylinder under the grill body or inside the grill enclosure or in the vicinity of any heat producing appliance. Failure to follow this information exactly could result in an explosion and/or fire causing death or serious injury.

WARNING
NEVER store a spare L.P. gas supply cylinder under the grill body or inside the grill enclosure or in the vicinity of any heat producing appliance. Failure to follow this information exactly could result in an explosion and/or fire causing death or serious injury.

WARNING
NEVER store a spare L.P. gas supply cylinder under the grill body or inside the grill enclosure or in the vicinity of any heat producing appliance. Failure to follow this information exactly could result in an explosion and/or fire causing death or serious injury.

WARNING
NEVER store a spare L.P. gas supply cylinder under the grill body or inside the grill enclosure or in the vicinity of any heat producing appliance. Failure to follow this information exactly could result in an explosion and/or fire causing death or serious injury.

WARNING
NEVER store a spare L.P. gas supply cylinder under the grill body or inside the grill enclosure or in the vicinity of any heat producing appliance. Failure to follow this information exactly could result in an explosion and/or fire causing death or serious injury.

WARNING
NEVER store a spare L.P. gas supply cylinder under the grill body or inside the grill enclosure or in the vicinity of any heat producing appliance. Failure to follow this information exactly could result in an explosion and/or fire causing death or serious injury.

WARNING
NEVER store a spare L.P. gas supply cylinder under the grill body or inside the grill enclosure or in the vicinity of any heat producing appliance. Failure to follow this information exactly could result in an explosion and/or fire causing death or serious injury.

WARNING
NEVER store a spare L.P. gas supply cylinder under the grill body or inside the grill enclosure or in the vicinity of any heat producing appliance. Failure to follow this information exactly could result in an explosion and/or fire causing death or serious injury.

WARNING
NEVER store a spare L.P. gas supply cylinder under the grill body or inside the grill enclosure or in the vicinity of any heat producing appliance. Failure to follow this information exactly could result in an explosion and/or fire causing death or serious injury.

WARNING
NEVER store a spare L.P. gas supply cylinder under the grill body or inside the grill enclosure or in the vicinity of any heat producing appliance. Failure to follow this information exactly could result in an explosion and/or fire causing death or serious injury.

WARNING
NEVER store a spare L.P. gas supply cylinder under the grill body or inside the grill enclosure or in the vicinity of any heat producing appliance. Failure to follow this information exactly could result in an explosion and/or fire causing death or serious injury.

WARNING