



# Pressurized Filter Up to 850 gallons

**REMINDER**  
CALL 1-888-412-6001  
BEFORE RETURNING TO STORE.



**Questions, problems, missing parts?** Before returning to your retailer, call our customer service department at 1-888-412-6001, 8 a.m.-6 p.m., EST, Monday-Friday, or email us at [customercare@geoglobalpartners.com](mailto:customercare@geoglobalpartners.com). Or visit our website [www.totalpond.com](http://www.totalpond.com).

## PACKAGE CONTENTS

Part	Description	Quantity
A	Tank	1
B	Cover	1
C	Lid	1
D	O-ring	1
E	Adapter	2
F	Gasket	2
G	Locking ring	2
H	Tube	2
I	Bio media balls	12
J	Small filter	1
K	Coarse filter	1
L	Fine filter	1

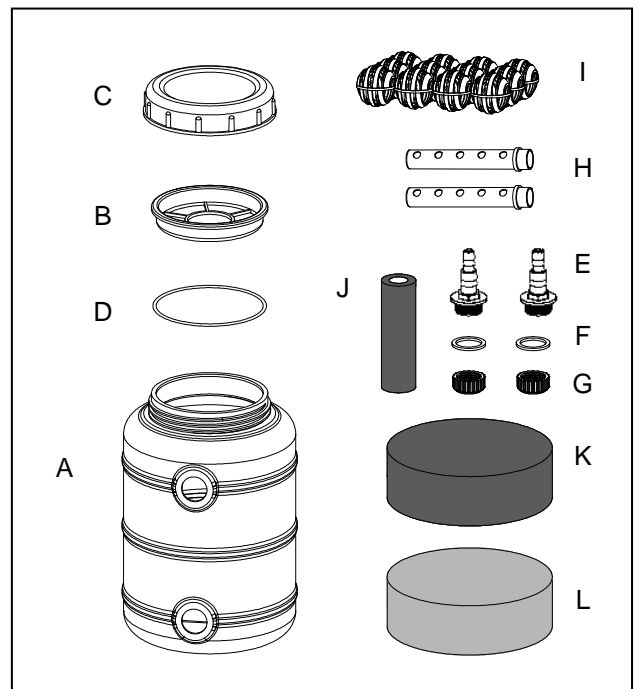

## PREPARATION

Before beginning assembly of product, make sure all parts are present. Compare parts with package contents list and diagram above. If any part is missing or damaged, do not attempt to assemble, install or operate the product. Contact customer service for replacement parts.

- Estimated Assembly Time: 20 minutes
- No tools required for assembly.

## ASSEMBLY INSTRUCTIONS

1. Assemble the tube, gasket and adapter. Insert the adapter and gasket into the outlet of the tank (lower hole). Fix it in place with the locking ring. Fig. 1

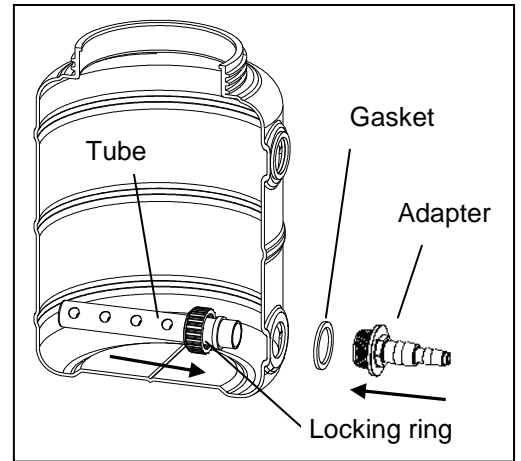

**Fig. 1**

2. Slide the small filter onto the tube. Fig. 2

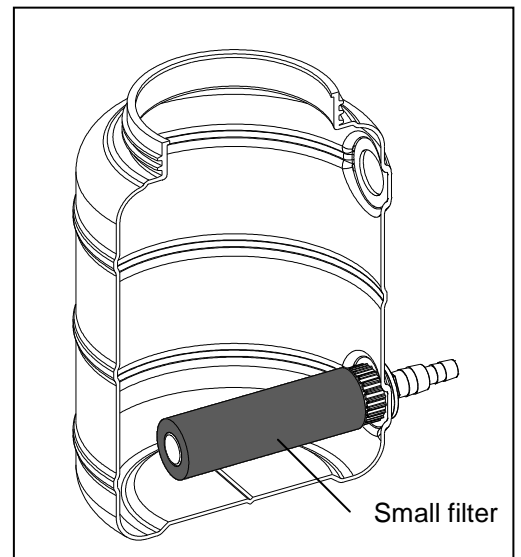

**Fig. 2**

3. Place the bio balls into the bottom of the tank. Fig. 3

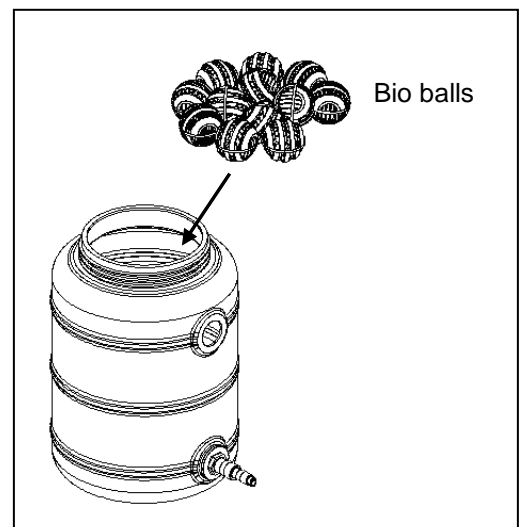

**Fig. 3**

- Place the fine filter pad inside the tank. Then place the coarse filter pad over the fine filter pad. Fig. 4

NOTE: The coarse filter pad is black. The fine filter pad is blue.

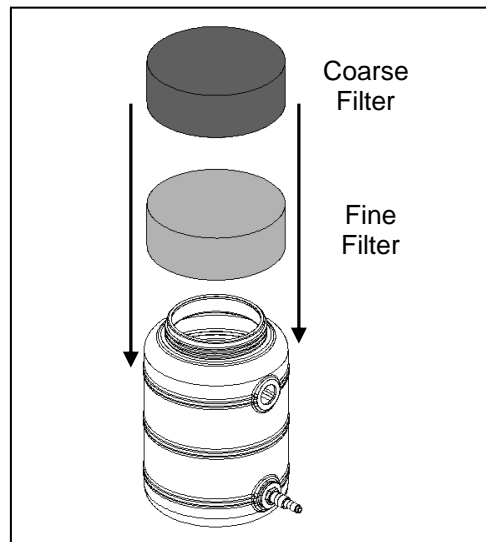

Fig. 4

- Assemble the tube, gasket and adapter. Insert the adapter and gasket into the inlet of the tank (upper hole). Fix it in place with the locking ring. Fig. 5

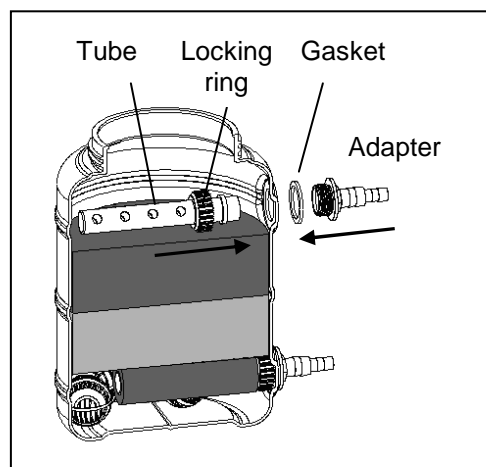

Fig. 5

- Turn over the cover and locate the groove. Place the o-ring into the groove. Fig. 6

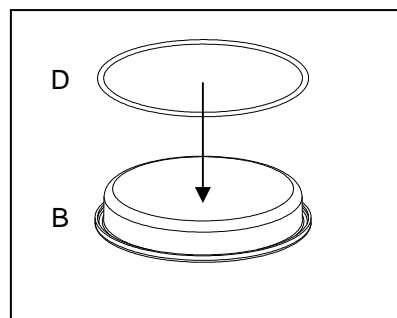
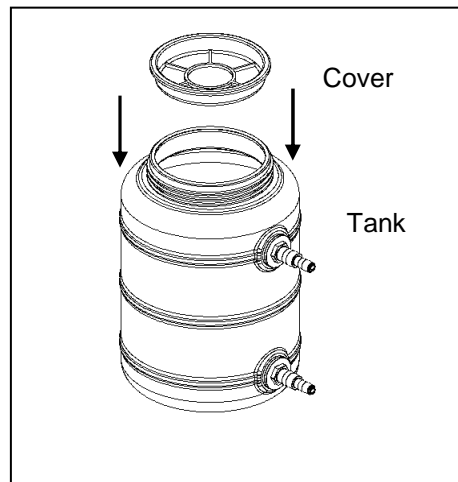

Fig. 6

- Place the cover (with the o-ring attached) over the top of the tank. Fig. 7



**Fig. 7**

- Screw the lid onto the top of the tank. Make sure that it is secure, or the filter will leak. Fig. 8

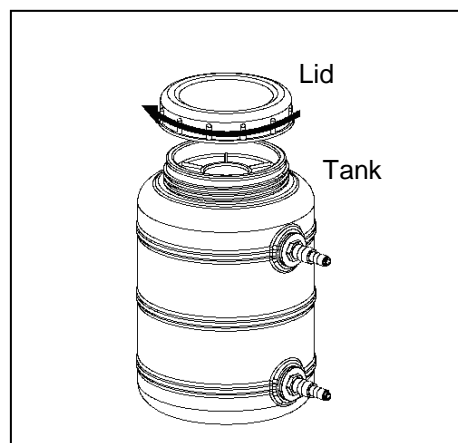

**Fig. 8**

- Connect a length of tube from the outlet of a pump to the inlet of the filter (upper hole). Connect a length of tubing from the outlet of the filter (lower hole) to a water feature. Fig. 9

NOTE: Pump and tubing is NOT INCLUDED. The adapter is compatible with 1/2 in. or 3/4 in. tubing.

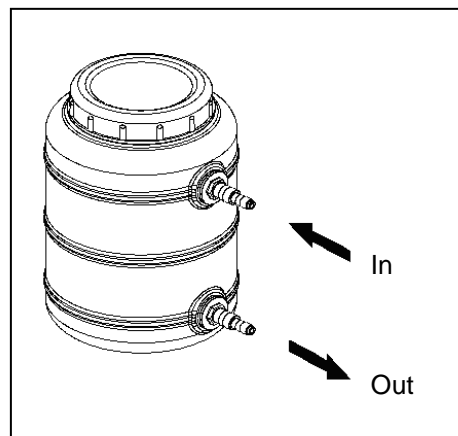

**Fig. 9**

## CARE AND MAINTENANCE

- Occasional cleaning of the filter pads will be necessary to ensure the proper functioning of the system. The top filter pad is a coarse pad (black) and will catch larger particles. The bottom filter pad (blue) is a fine pad designed to trap smaller debris. Both pads should be removed and washed with clean water when they are visibly soiled.
- Filter pads should be replaced annually. Use TotalPond Replacement Filter Pads item # RF13026.
- Filter pads should be changed annually. The exterior surface of the filter box may also need occasional cleaning. Do not use any chemicals that may destroy the beneficial bacteria.
- The bio balls in you filter system and the inside surfaces of the filter box contain the beneficial bacteria. At least once a year the entire system should be disassembled and cleaned thoroughly using warm, soapy water (biodegradable soap). This should not be done during the warm season as it may take up to 8 weeks to re-establish the environmental balance. The best time of the year to “breakdown” your system is in early spring before the water temperatures begin to rise. This is also the ideal time to replace the filter pads.

## REPLACEMENT PARTS LIST

For replacement parts, call our customer service department at 1-888-412-6001, 8 a.m.-6 p.m., EST, Monday-Friday.

Part	Description
A	Tank
B	Cover
C	Lid
D	O-ring
E	Adapter
F	Gasket
G	Locking ring
H	Tube

TotalPond replacement filters can be purchased at Home Depot, item #RF13026.

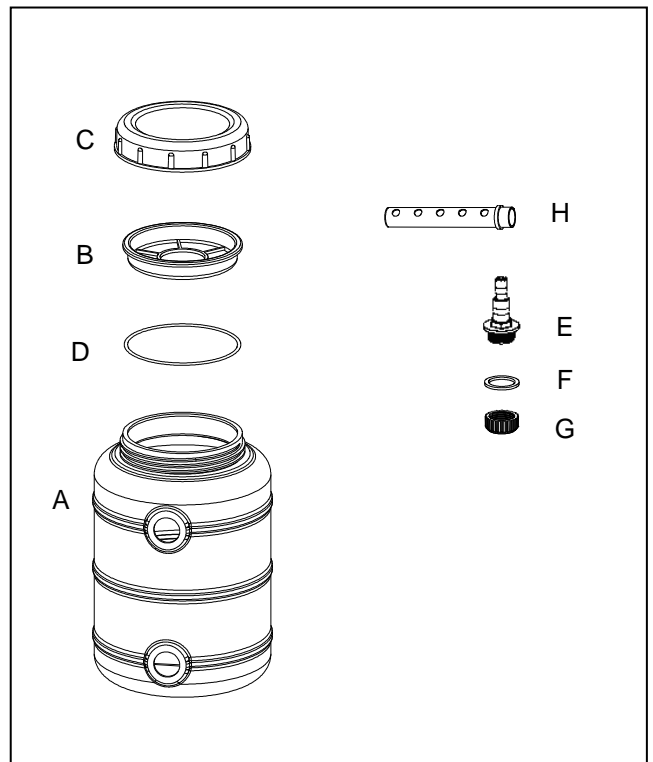

## LIMITED WARRANTY

---

All pumps and electrical products are warranted to the user against defective material and workmanship, under normal working conditions. This warranty period begins on the date of purchase by the original purchaser.

All TotalPond® electrical products are warranted to the user against defective material and workmanship, under normal working conditions for 1 year from the date of purchase. All TotalPond® liners are warranted to the user against defective workmanship, under normal working conditions for 20 years from the date of purchase. All other TotalPond® product is warranted to the user against defective material and workmanship, under normal working conditions for 90 days.

### **Application**

Warranty covers only properly installed and maintained units. Pump warranty is limited to applications pumping fresh water in a pond or fountain only. Other liquid applications or extreme temperature uses must be approved in writing by the manufacturer. Receipt and product date code are required for warranty claims.

### **Warranty Claim**

**Warranty claims must be made by calling customer service (at 1-888-412-6001).** If the item is determined to be defective, you will be given authorization to return the defective part(s), freight pre-paid, along with proof of purchase.

### **Disposition**

The manufacturer will make a good faith effort for prompt disposition regarding all warranty claims. Returned product will be inspected to determine cause of failure before warranty is applied. Warranty does not cover any costs associated with the shipping, handling, installation or removal of products or parts subject to this warranty. For products damaged in transit, a claim should be filed with the carrier.

### **Disclaimer**

Any oral statements made about the product by the seller, the manufacturer, the representatives, or any other parties do not constitute warranties, should not be relied upon by the user, and are not part of the contract for sale. The seller's and manufacturer's only obligation, and buyer's only remedy shall be for the manufacturer to either replace and/or repair at the manufacturer's sole discretion, the product as described above. Neither seller nor the manufacturer shall be liable for injury, loss or damages for lost profits, lost sales, injury to person or property, or any other incidental or consequential loss arising from any cause whatsoever, no matter whether based upon warranty, contract, negligence or other misuse, and the buyer and user agree that no other remedy shall be available to them. Before using, the buyer and user shall determine the suitability of the product for the intended use, and assume all risk and liability whatsoever in connection therewith. The warranty and remedy described in this limited warranty is an exclusive warranty and remedy in lieu of any other warranty or remedy expressed or implied. All other warranties and remedies are hereby expressly excluded, including but not limited to any implied warranty of merchantability of fitness for any particular purpose. This warranty gives the buyer and user specific legal rights, and buyer and user may also have other rights which vary from state to state. Some states do not allow exclusions or limitations of incidental or consequential damages, so the above limitations or exclusions may not apply to you.

**REMINDER**  
**CALL 1-888-412-6001**  
**BEFORE RETURNING TO STORE.**