

**INSTRUCTION MANUAL ENCLOSED**

**ATTENTION**

**IF YOU HAVE ANY PROBLEMS OR QUESTIONS, EMAIL OR CALL  
CUSTOMER SERVICE BEFORE YOU RETURN THIS PRODUCT TO THE  
STORE WHERE IT WAS PURCHASED.**

For Customer Service:

USA: Email: [support@orderhelp.com](mailto:support@orderhelp.com) /Call: 1-877-897-1222

CANADA: Email: [sirio@orderhelp.com](mailto:sirio@orderhelp.com) /[www.sirio.ca](http://www.sirio.ca)

/Call: 1-866-666-0421

**INSTRUCTION MANUAL ENCLOSED**





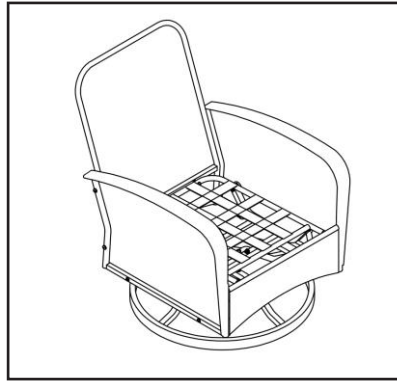

# SWIVEL CHAIR





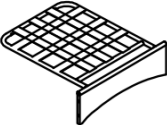

## CC034&CC035&CC034-GYBU

### SWIVEL CHAIR ASSEMBLY INSTRUCTION



Part	PARTS LIST Description	Quantity
<i>PARTS</i>		
A	Right Armrest	1
B	Left Armrest	1
C	Chair Seat	1
D	Chair Back	1
E	Rocking Track	1
F	Swivel Chair Base	1
<i>HARDWARE</i>		
G	Bolts M6*15mm	4
H	Bolts M6*35mm	14
I	Washers A	18
J	Washers B	4
K	Screw Nuts	8
L	Allen Key	1
L	Hex Spanner	1

A 	B 	C 	D 	E 	F 
X1	X1	X1	X1	X1	X1

G  M6*15	H  M6*35	I 	J 	K 	L 	M 
X4	X14	X18	X4	X8	X1	X1

For Customer Service:

Email: [support@orderhelp.com](mailto:support@orderhelp.com)

[sirio@orderhelp.com](mailto:sirio@orderhelp.com) / [www.sirio.ca](http://www.sirio.ca)

Call: 1-877-897-1222 / 1-866-666-0421

# PLEASE READ AND FOLLOW ALL SAFETY TIPS

## GETTING STARTED

1. Before assembly, CAREFULLY use scissors or utility knife to cut and unwrap all parts. Make sure you do not discard the hardware.
2. Make sure that you have all the parts listed. If you are missing any parts, please email Customer Service: USA: support@orderhelp.com or call 1-877-897-1222. Canada: www@sirio.ca or call 1-866-666-0421. Please identify the parts you need and model number. Make sure to include your name and address.

\*\*\*Tips: Do not fasten all bolts completely tight until finish all steps.

1. Locate the Armrests(A & B) to the Chair Back(D) by the pre-drilled threads. Fasten Bolts(G) with Washers A(I) by using Allen Key(H) to combine armrests and chair back together. 4 bolts should be fastened totally. (Step 1)

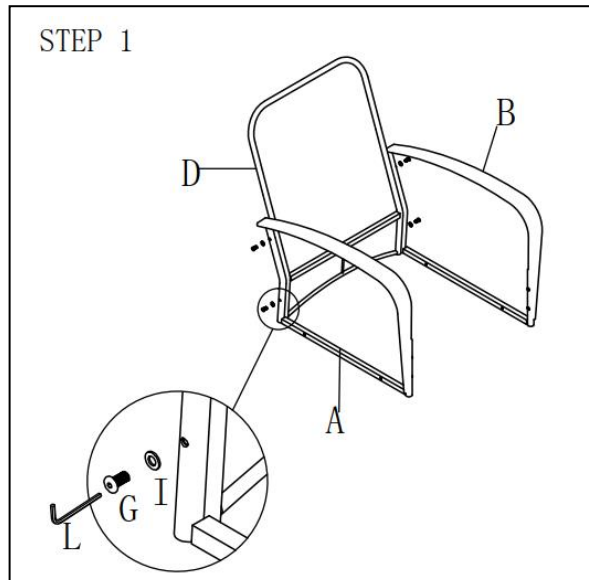

2. Locate the Chair Seat(C) to the Armrests(A & B) by the pre-drilled threads. Fasten Bolts(H) with Washers A(I) by using Allen Key(L) to combine armrests and chair seat together. 4 bolts should be fastened totally. (Step 2)

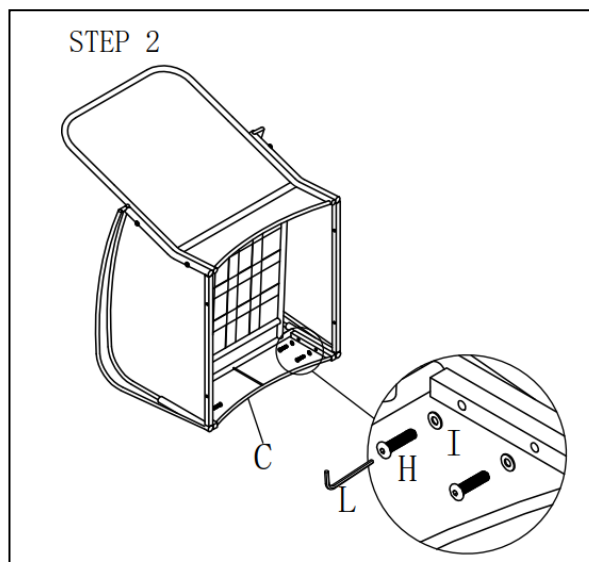

3. Locate the Chair Seat(C) to the Chair Back(D) by the pre-drilled threads. Fasten Bolts(H) with Washers A(I) by using Allen Key(L) to combine chair seat and chair back together. 2 bolts should be fastened totally. (Step 3).

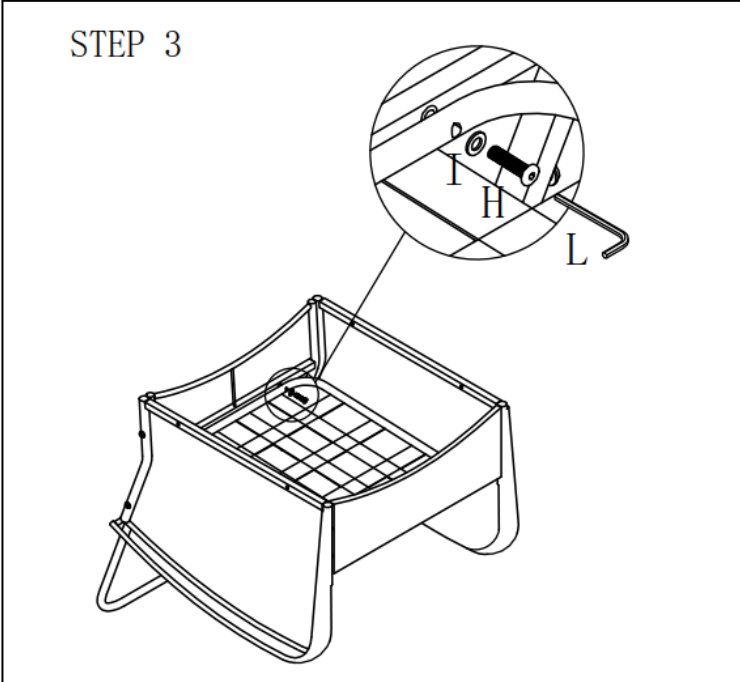

4. Locate the Rocking Track(E) to the Armrests' bottom(A & B) by the pre-drilled threads. Fasten Bolts(H) into Screw Nuts(K) by using Allen Key(L) and Hex Spanner(M) to combine rocking rack and the chair main part together. 4 bolts should be fastened totally. (Step 4).

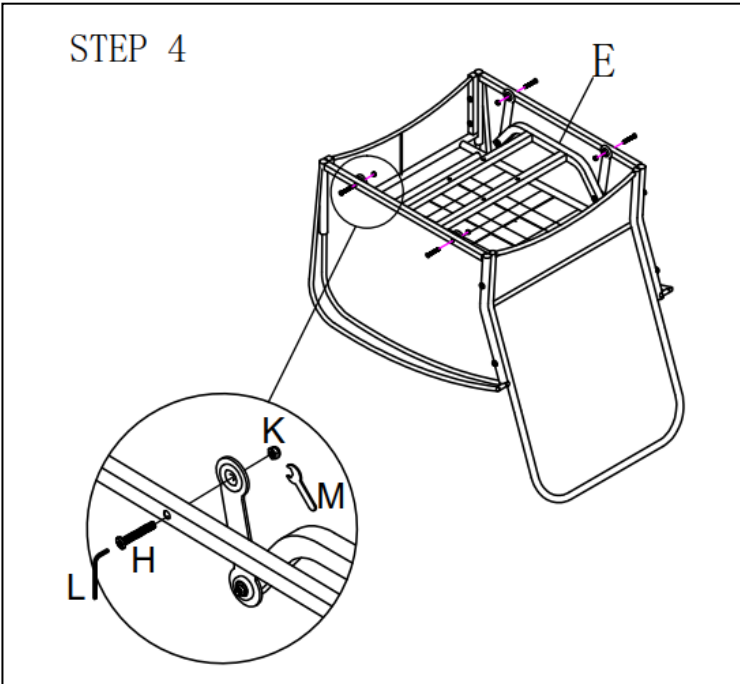

5. Locate the Rocking Track(F) to the Rocking Rack(E) by the pre-drilled threads. Fasten Bolts(H) with Washers A(I) and Washers B(J) into Screw Nuts(K) by using Allen Key(L) and Hex Spanner(M). 4 bolts should be fastened totally. 8 Washers A and 4 Washers B are needed for this step (Step 5).

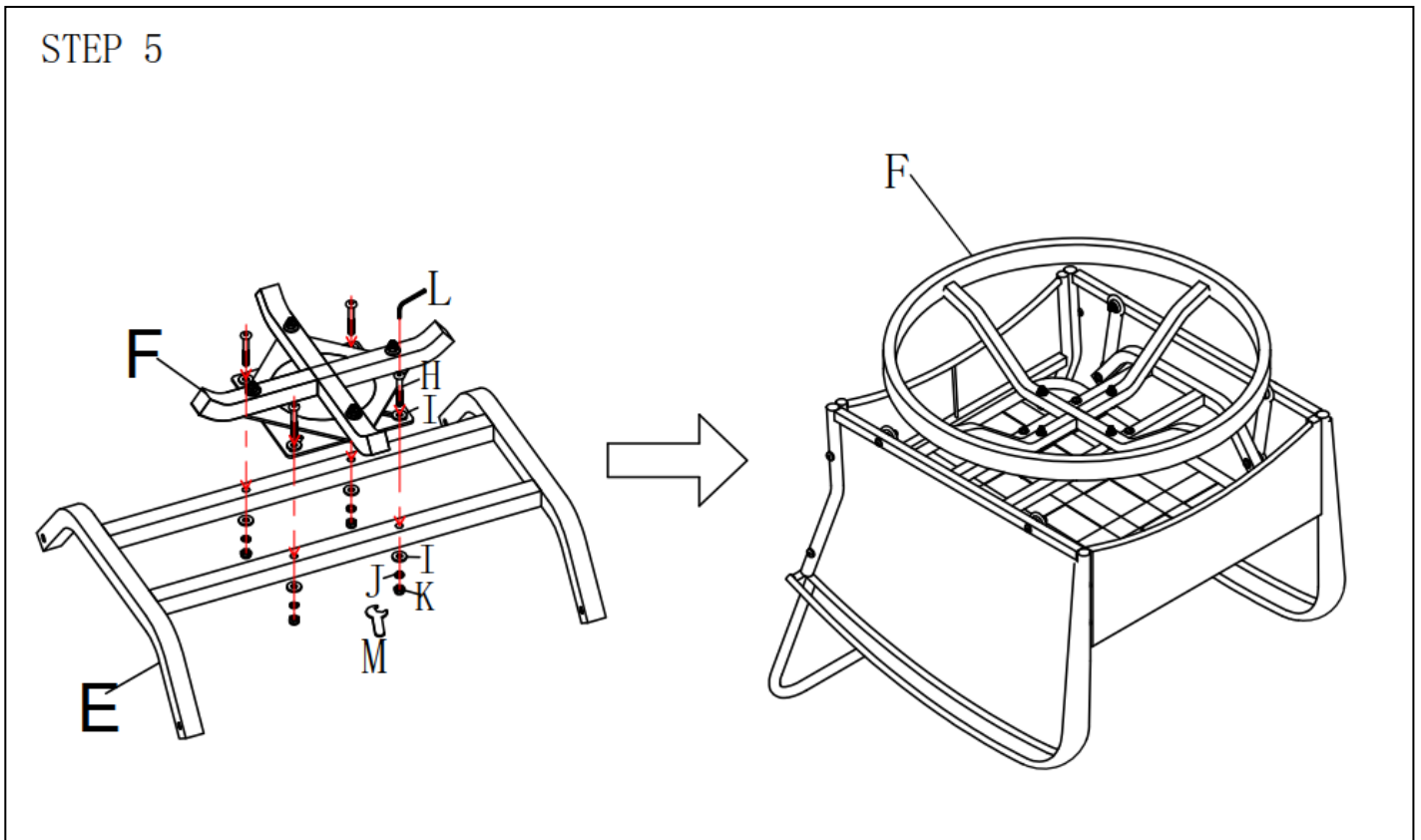

6. Fasten all bolts tight.

Till now you have finished the whole assembly and enjoy your chair!!