



Introduction

Thanks for choosing Bistro Set. Our success depends on happy customers and we hope you will be pleased with your purchase. If there are missing part or broken parts, or if you need futher assistance, please contact customer service online.

◆Notice:

1. 50% Tighten before fixing all screws.
2. Place the item on a flat ground to adjust and make sure it remains stable
3. Tighten up all screws with tools gradually
4. If the screws are not aligned with holes during assembly, please loosen all the other screws to 50% and continue the assembly process.
5. If the item is not stable, please loosen all the screws, adjust it on a flat ground and tighten up all screws again

Table Part List:

No.	Picture	Parts	Qty	No.	Picture	Parts	Qty
A		Table Top	1	H		Spring Washer (8MM)	4
B		Table leg	4	I		Nut (8MM)	4
C		Leg Support	1	J		Flat Washer (8MM)	8
D		Cover	1	K		Spring Washer (8MM)	8
E		Ice Bucket	1	L		Nut (8MM)	8
F		Stud M8*30	4	M		Wrench	1
G		Flat Washer (8MM)	4	N		Stud M8*35	8

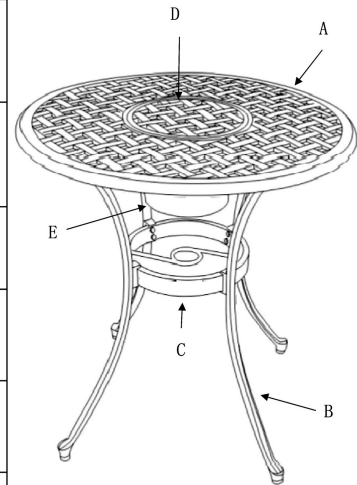

Assembly Instructions

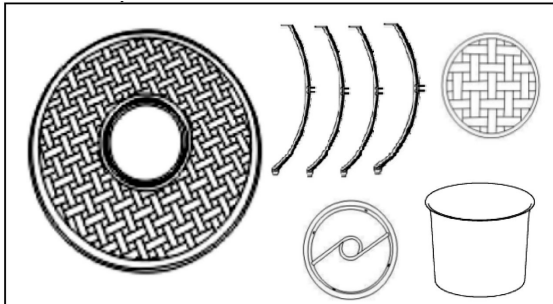

1. Unpack and place all parts on a clean soft surface.

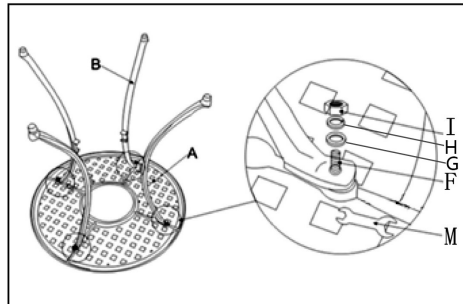

2. Attach part B table legs to part A table top with four part F studs, four part G flat washers, four part H spring washers, and four part I nuts.
DO NOT OVER TIGHTEN

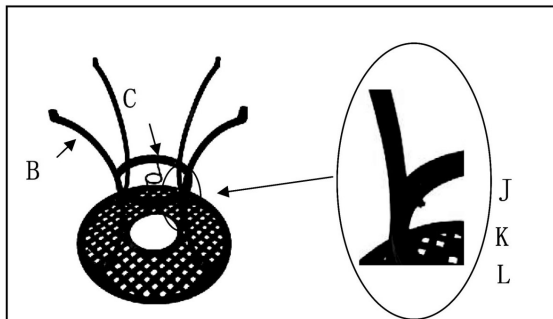

3. Attach part C leg support to part B table legs with four part N studs, four part J flat washers, four part K spring washers, and four part L nuts.
DO NOT OVER TIGHTEN

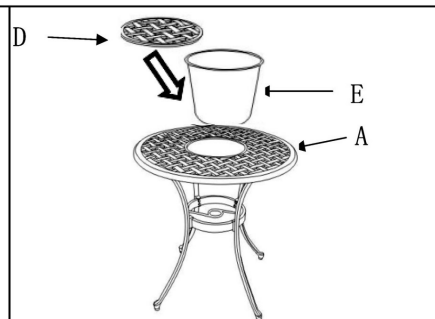

4. Insert part E ice bucket into the middle of part A table top. Place part D cover on top of ice bucket.



5. Flip table upright and adjust the pre-installed leveler until the table is level with the ground.
6. Securely tighten all nuts.

Chair Part List:

No.	Picture	Parts	Qty	No.	Picture	Parts	Qty	No.	Picture	Parts	Qty
F		Backrest	1	I		Right Arm	1	L		Washers(8mm)	10
G		Chair Seat	1	J		Left Arm	1	L		Spring washers(8mm)	10
H		Chair leg	4	K		Washers(6mm)	4	L		Nuts(8mm)	10
						Spring washers(6mm)	4	M		Plastic cap(6mm)	2
						Nuts(6mm)	4	N		Bolts M6*30	4
								O		Allen Wrench	1
								P		Stud M8*30	10
								Q		Wrench	1

Assembly Instructions

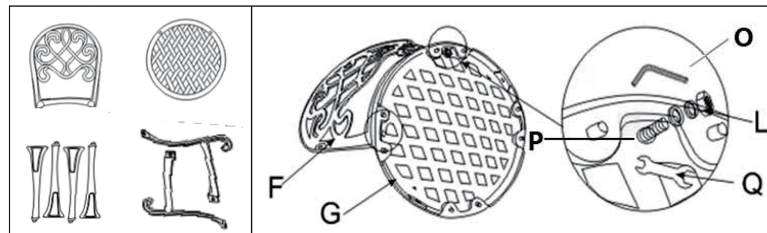

1. Unpack and place all parts on a clean soft surface.

2. Use part O Allen wrench and part Q wrench to attach part F backrest to part G chair seat with two part P studs, and two part L washers, spring washers, and nuts. DO NOT OVERTIGHTEN.

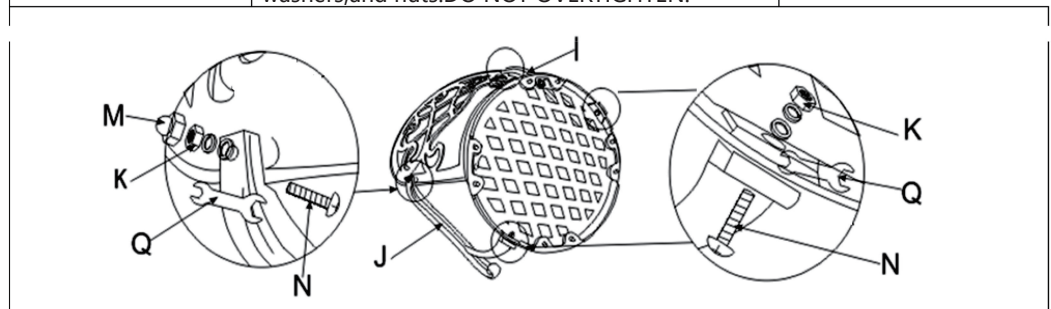

3. Attach part I right arm and part J left arm to part G chair seat with four part N bolts, four part K washers, spring washers, and nuts, and two part M plastic caps.

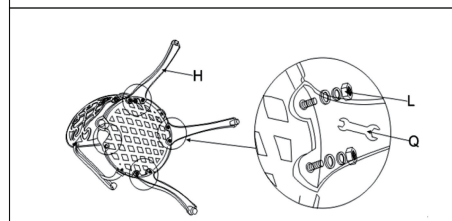

4. Use part Q wrench to attach part H chair legs to part G chair seat with two part L nuts, washers, and spring washers per leg.
DO NOT OVERTIGHTEN.

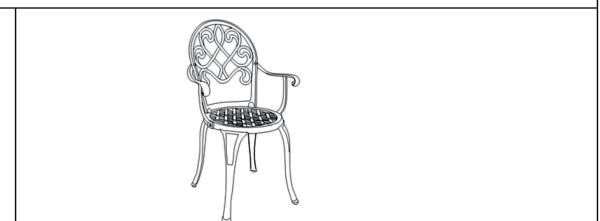

5. Flip chair upright and adjust the pre-installed levelers until the the chair is level with the ground.
6. Securely tighten all bolts, nuts, and screws.