

Tamarack Technologies HV3400 Ghost Whole House Fan
Cools The Indoor Air
of your **WHOLE HOUSE!**



- Energy Efficient
- Easy Installation
- No Maintenance
- Remote Control
- Mechanically Sealed Doors
Insulated
to R38 or R50
- 3400 CFM High
- 1900 CFM Low
- 6' Line Cord

GHOST WHOLE HOUSE Fan

The Ghost Whole House Fan economically reduces the temperature of the home by bringing cool outside air in through the windows, while pushing hot stale air up and out through existing attic vents. The Ghost is a two speed fan equipped with a radio frequency remote control and interior ceiling grille.

LIKE US ON
FACEBOOK



FOLLOW US
ON TWITTER



Tamarack
Technologies, Inc.

Ventilation Solutions

www.tamtech.com

800-222-5932



Cools The Indoor Air of your WHOLE HOUSE!

SPECIFICATIONS

Electrical:

Voltage	115 VAC 60Hz
Power	(High Speed.) 450 Watts (Low Speed.) 340 Watts

Air Flow

High Speed	3400 CFM*
Low Speed	1900 CFM*

Operation

30 second door delay before fans start

Insulation Value of Closed Doors

R-38 or R-50

Weight

Fan Weight: 48 Lbs. Ships in 2 boxes

Top Housing

26 1/4" L x 26" W x 14 1/8" H

Lower Housing

25 7/8" L x 29 1/2" W x 13 5/8" H

Attic Ventilation Requirements

9 Square Feet

DIMENSIONS

Allow 2 feet of clearance above fan for best operation

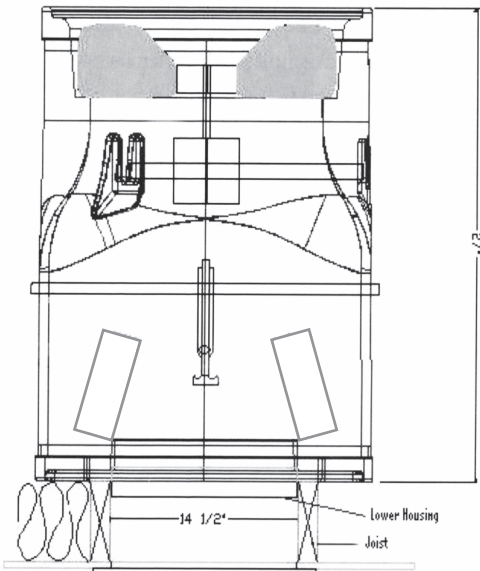

The Ghost ships with a radio frequency remote control but can be hardwired to wall switches.

*CFM rates measured in a controlled test environment. Actual results will vary due to building construction.

Installation instructions include an optional hard wire configuration for fan operation: Recommended controls are an SPST wall switch, or a non-digital spring wound mechanical timer. All other controls will void the product warranty.



Tamarack
Technologies, Inc.

Ventilation Solutions
www.tamtech.com

800-222-5932