

1 : Overhead Valve

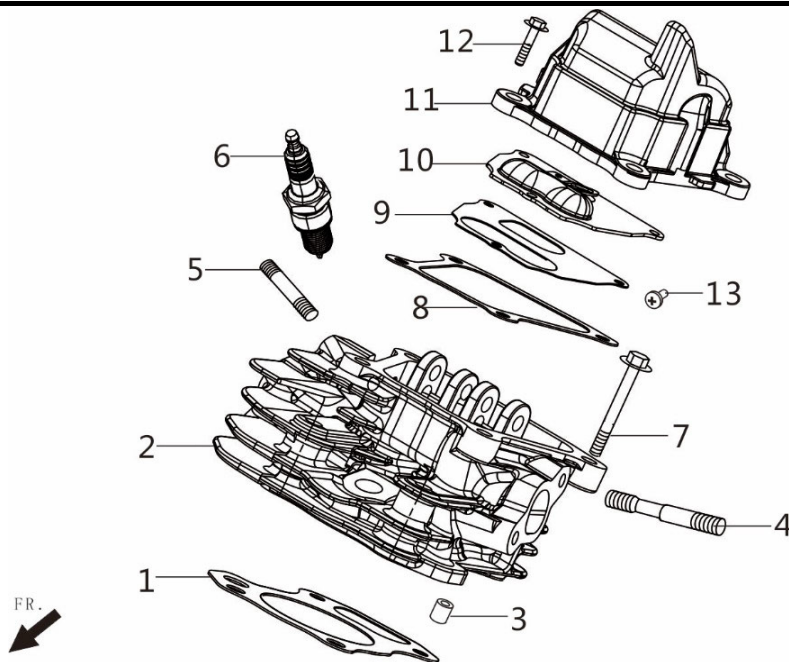

REF.NO.	PART NO	DESCRIPTION	Q'TY
E01-1	148.3020.001.00.00	GASKET, CYLINDER HEAD	1
E01-2	148.0010.001.00.00	CYLINDER HEAD	1
E01-3	188.3170.001.00.00	PIN	2
E01-4	0900.06090.00.01	STUD	2
E01-5	0900.06025.00.01	STUD	2
E01-6	148.2160.001.00.00	PLUG, SPARK	1
E01-7	5789.06050.00.03	BOLT, CYLINDER HEAD	4
E01-8	148.3000.001.00.00	GASKET, COVER SUBASSEMBLY	1
E01-9	148.3088.001.00.00	Breathing slice combination	1
E01-10	148.7061.001.00.00	GASKET, BREATHING	1
E01-11	148.0001.001.00.00	COVER SUBASSEMBLY, CYLINDER HEAD	1
E01-12	5789.06020.00.01	BOLT	4
E01-13	0818.03008.00.01	Cross recessed pan head screw	3

FIG.2 CRANKCASE./COVER SUBASSEMBLY, CRANKCASE

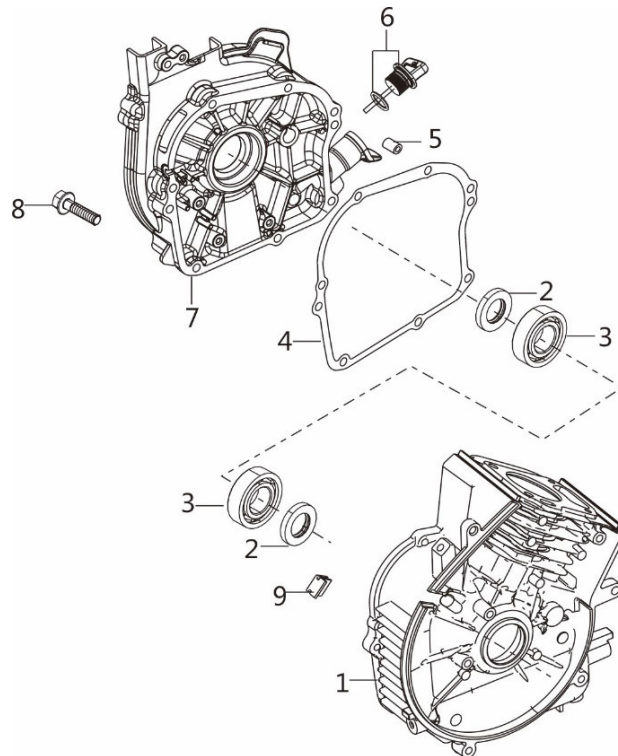

REF.NO.	PART NO	DESCRIPTION	Q'TY
E02-1	148.1000.001.00.00	CRANKCASE SUBASSEMBLY.	1
E02-2	148.3150.001.00.00	OIL-SEAL	2
E02-3	148.0280.001.00.00	BEARING	2
E02-4	148.3040.001.00.00	GASKET, CRANKCASE	1
E02-5	188.3170.001.00.00	PIN	2
E02-6	168.1230.001.00.00	DIPSTICK SUBASSEMBLY, OIL	1
E02-7	148.1010.001.00.00	OVER SUBASSEMBLY, CRANKCASE	1
E02-8	5789.06020.00.01	BOLT	7
E02-9	148.6487.001.00.00	Rubber plug	1

FIG.3 RING SET,OIL / ROD,CRANKSHAFT CONNETING

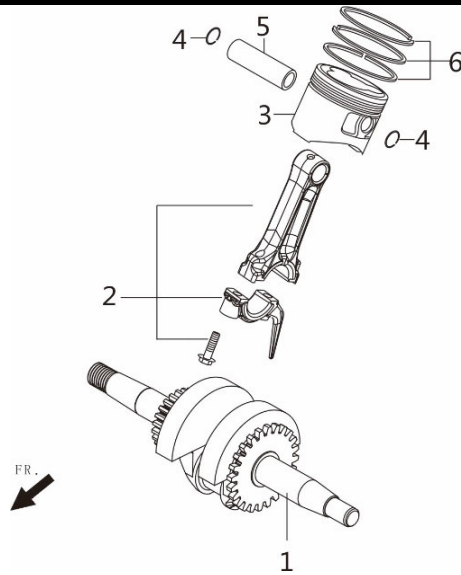

REF.NO.	PART NO	DESCRIPTION	Q'TY
E03-1	148.0180.001.00.00	CRANKSHAFT ASSY.	1
E03-2	148.0190.001.00.00	ROD, CONNECTING	1
E03-3	148.0200.001.00.00	PISTON	1
E03-4	148.0230.001.00.00	CLIP, PISTON PIN	2
E03-5	148.0220.001.00.00	PIN, PISTON	1
E03-6	148.0210.001.00.00	RING SET, OIL	1

FIG.4 TRAIN,VALVE / CAMSHAFT SUBASSEMBLY

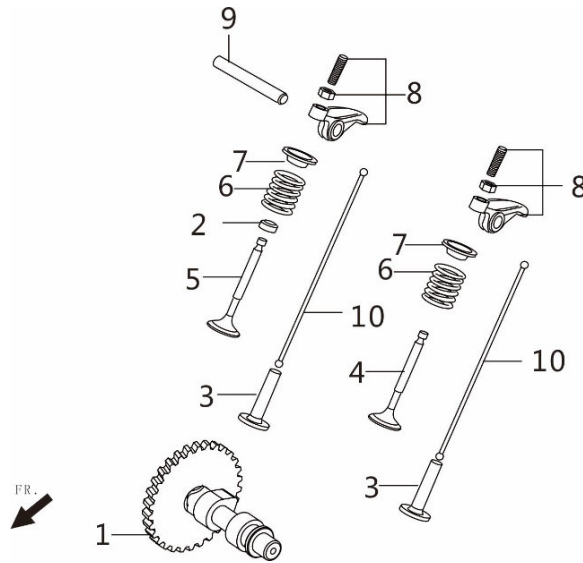

REF.NO.	PART NO	DESCRIPTION	Q'TY
E04-1	148.1040.001.00.00	CAMSHAFT ASSY.	1
E04-2	148.0085.001.00.00	OIL BAFFLE	1
E04-3	148.1030.001.00.00	TAPPET	2
E04-4	148.0020.001.00.00	INTAKE VALVE	1
E04-5	148.0030.001.00.00	EXHAUST VALVE	1
E04-6	148.0040.001.00.00	VALVE SPRING	2
E04-7	148.0060.001.00.00	VALVE-SPRING SEAT	2
E04-8	148.0100.001.00.00	VALVE ROCKER	2
E04-9	148.0101.001.00.00	VALVE ROCKER SHAFT	1
E04-10	148.0160.001.00.00	RODS	2

FIG.5 STARTER,RECOIL

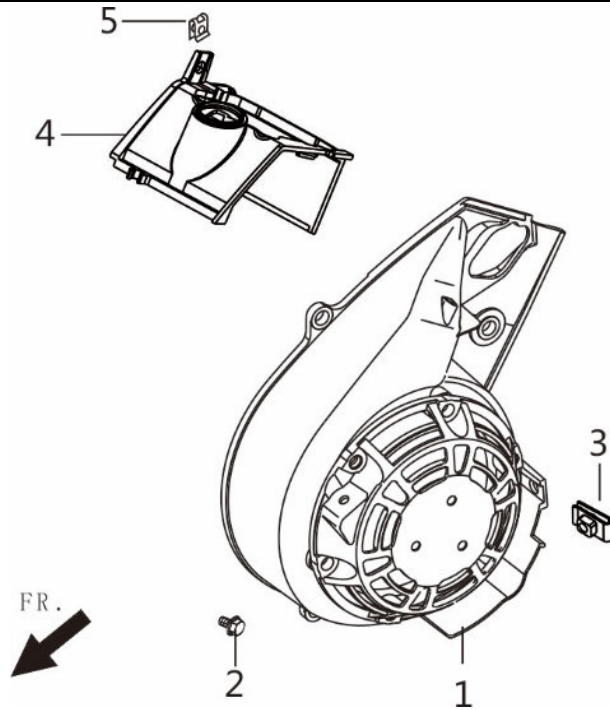

REF.NO.	PART NO	DESCRIPTION	Q'TY
E05-1	148.2000.001.00.00	STARTER,RECOIL	1
E05-2	5789.06016.00.01	BOLT	4
E05-3	6178.05000.00.04	NUT	1
E05-4	148.2230.001.00.00	Air guide plate, CYLINDER HEAD	1
E05-5	148.4701.001.00.00	CLIP	1

FIG.6 FLYWHEEL / IMPELLER / STARTER PULLEY / IGNITION COIL

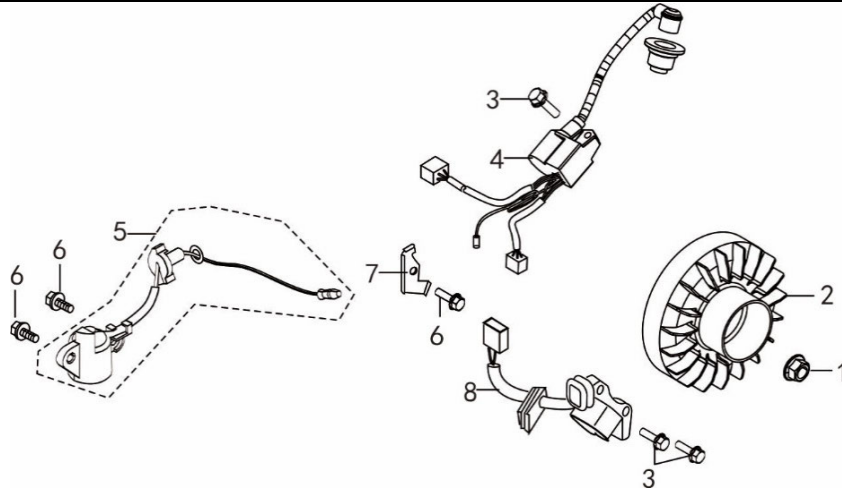

REF.NO.	PART NO	DESCRIPTION	Q'TY
E06-1	6177.12000.05.01	NUT, FLYWHEEL	1
E06-2	148.2040.001.00.00	FLYWHEEL SUBASSEMBLY	1
E06-3	5789.06020.00.01	BOLT	3
E06-4	148.1522.001.00.00	IGNITION	1
E06-5	148.1020.001.00.00	OIL ALERT	1
E06-6	5789.06012.00.01	BOLT	3
E06-7	148.2090.001.00.00	PLATE,OIL ALERT	1
E06-8	148.2050.001.00.00	COIL, IGNITION	1

FIG.7 CARBURETOR ASSY.

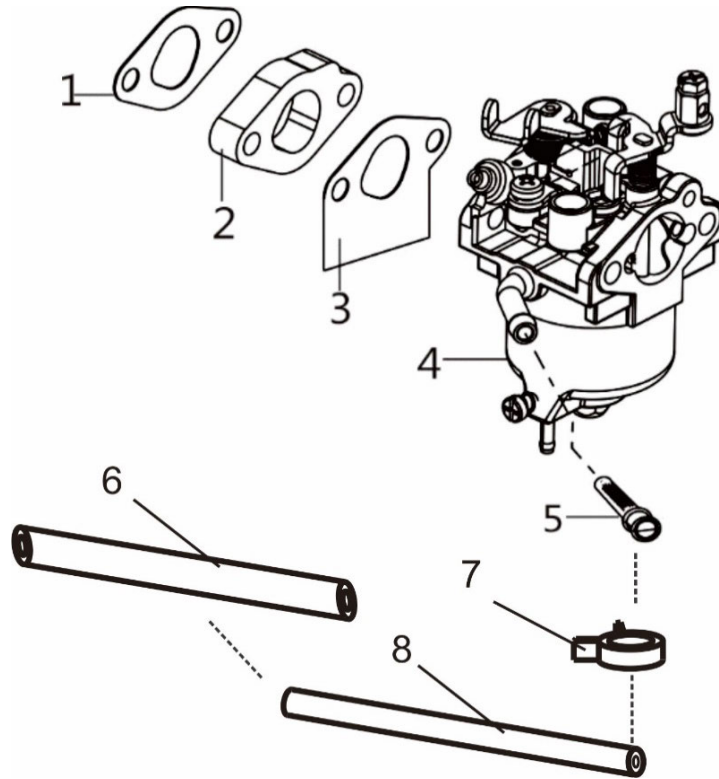

REF.NO.	PART NO	DESCRIPTION	Q'TY
E07-1	148.3090.001.00.00	GASKET, CARBURETOR	1
E07-2	148.2300.001.00.00	PLATE, CARBURETOR INSULATOR	1
E07-3	148.3080.001.00.00	GASKET, CARBURETOR INSULATOR	1
E07-4	148.2260.001.00.00	CARBURETOR ASSY.	1
E07-5	148.2610.001.00.00	filter,CARBURETOR	1
E07-6	467.2332.001.00.00	silicone protective cover	1
E07-7	458.2360.003.00.00	clamp,oil tube	1
E07-8	168.2330.C20.00.00	inlet tube,carburetor	1

FIG.8 MUFFLER ASSY.

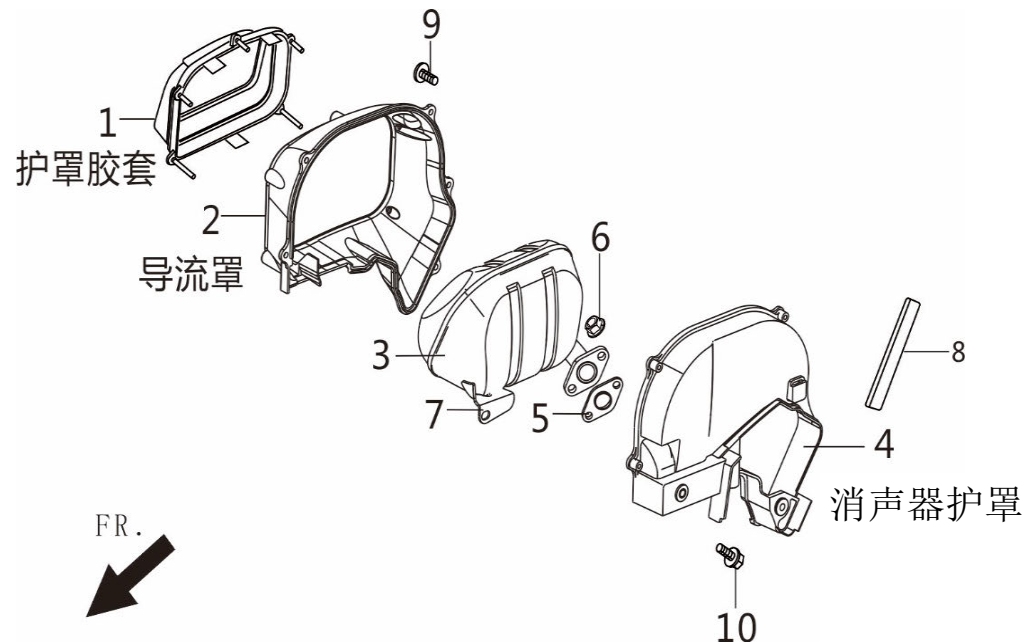

REF.NO.	PART NO	DESCRIPTION	Q'TY
E08-1	148.5231.001.00.00	GUM COVER, MUFFLER SHIELD	1
E08-2	148.2450.001.00.00	WIND SCOOPER, MUFFLER	1
E08-3	148.2400.001.00.00	MUFFLER ASSY.	1
E08-4	148.2420.001.00.00	MUFFLER SHIELD	1
E08-5	148.3100.001.00.00	GASKET, EXHAUST OUTLET	1
E08-6	6177.06000.00.01	HEXAGON NUTS WITH FLANGE	2
E08-7	5789.06012.00.01	HEXAGON BOLTS WITH FLANGE	1
E08-8	148.5232.001.00.00	STRIPPER RUBBER, MUFFLER SHIELD	1
E08-9	0845.48016.00.01	Cross groove small head self-tapping screw	5
E08-10	5789.06016.00.01	HEXAGON BOLTS WITH FLANGE	2

FIG.9 CLEANER, AIR (F02)

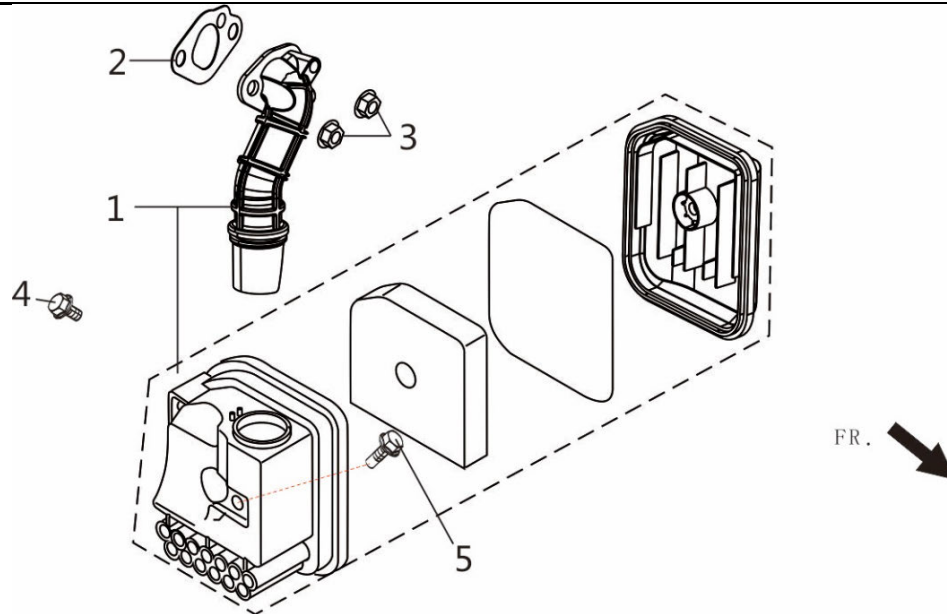

REF.NO.	PART NO	DESCRIPTION	Q'TY
F09-1	148.2280.001.00.00	Air cleaner assy.	1
F09-2	148.3060.001.00.00	GASKET, air cleaner	1
F09-3	6177.06000.00.01	HEXAGON NUTS WITH FLANGE	2
F09-4	5789.05018.00.01	HEXAGON BOLTS WITH FLANGE	1
F09-5	5789.06020.00.01	HEXAGON BOLTS WITH FLANGE	1

FIG.10 TANK, FUEL

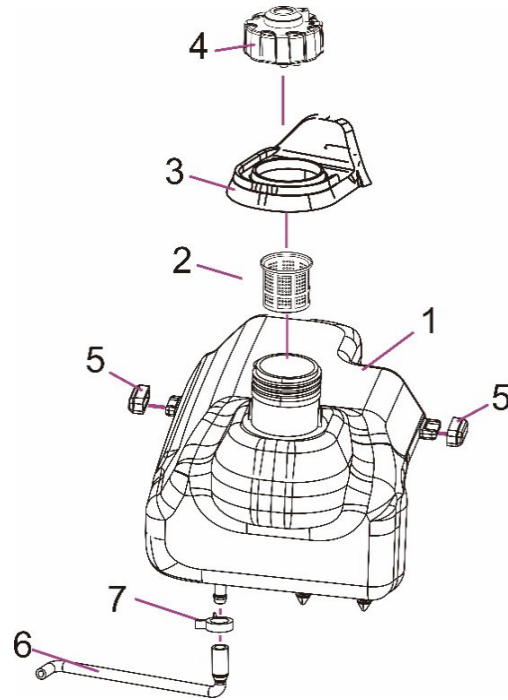

REF.NO.	PART NO	DESCRIPTION	CHINSES	Q'TY	PRICE (\$)
10-1	467.3200.001.00.00	TANK, FUEL	油箱	1	
10-2	467.3200.001.00.02	FUEL FILTER	燃油滤网	1	
10-3	467.3200.001.00.03	SHEATH	注油口胶套	1	
10-4	467.3200.001.00.01	TANK CAP	油箱盖	1	
10-5	467.5522.003.00.00	SHEATH	油箱支撑胶套C	2	
10-6	148.2330.C02.00.00	OIL TUBE	油管	1	
10-7	458.2360.007.00.00	FERRULE	带形油管夹	1	

FIG.11 : TAIL COVER

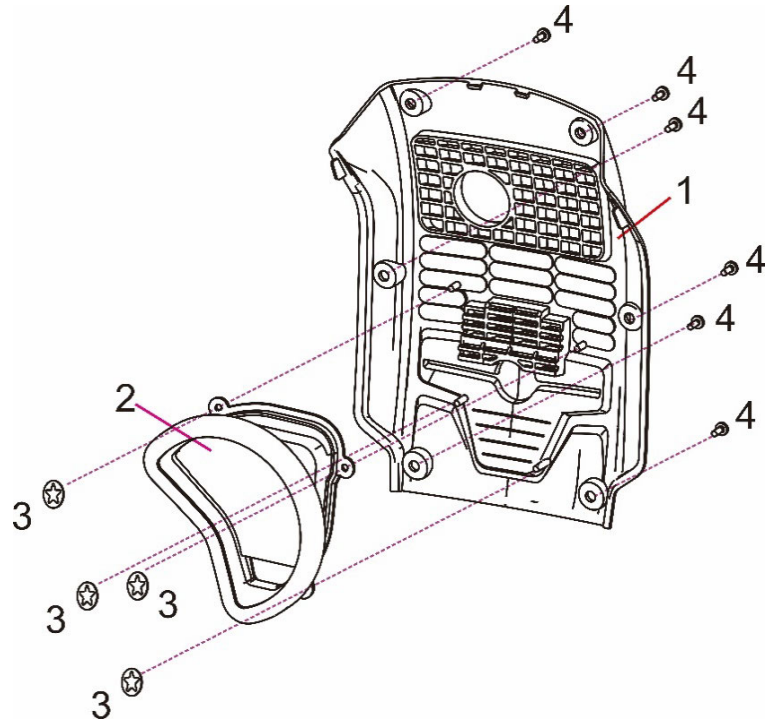

REF.NO.	PART NO	DESCRIPTION	Q'TY
11-1	467.2435.001.04.00	Tail cover	1
11-2	467.5599.001.00.00	ventilate sheath	1
11-3	467.5598.001.00.00	plum ring	4
11-4	0818.05016.00.07	Cross recessed pan head screw	6

FIG.12 : SHELL

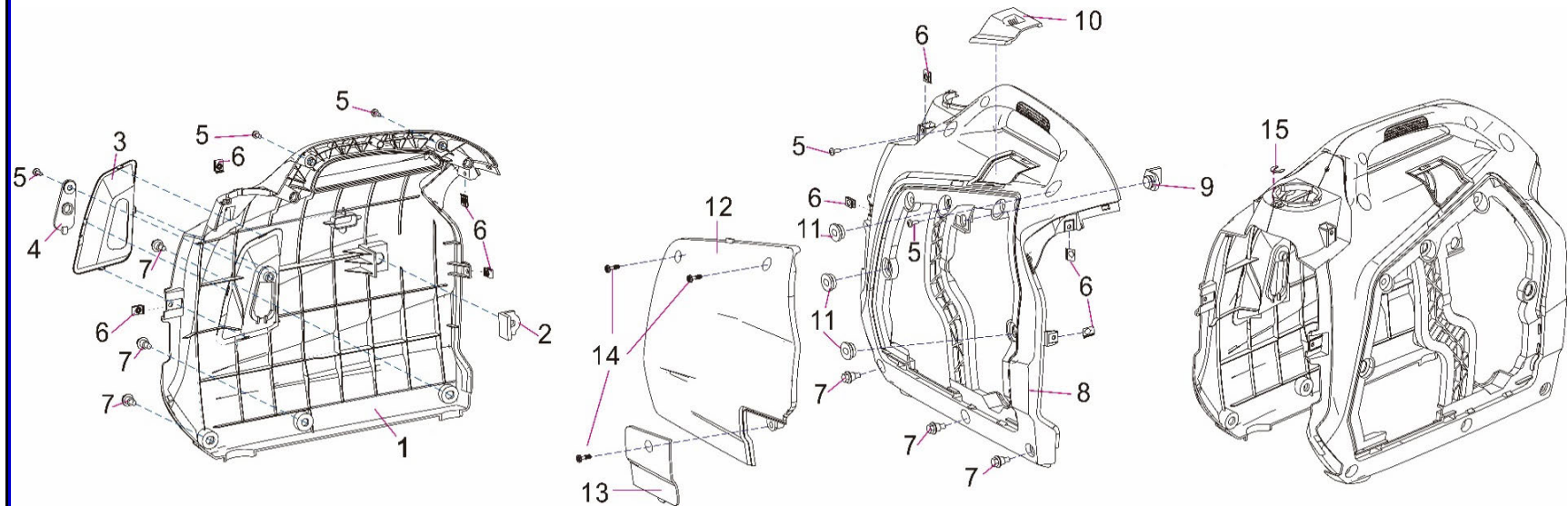

REF.NO.	PART NO	DESCRIPTION	Q'TY
12-1	467.2220.001.15.00	LEFT SHELL	1
12-2	467.6234.001.00.00	sheath	1
12-3	467.2221.001.00.00	ornament shell	1
12-4	148.2186.001.00.00	Cover plate	1
12-5	0818.05016.00.07	Cross recessed pan head screw	5
12-6	6178.05000.00.04	NUT	8
12-7	467.4789.001.00.00	step bolts	6
12-8	467.2222.001.15.00	RIGHT SHELL	1
12-9	467.6234.002.00.00	sheath	1
12-10	467.4259.001.15.00	Spark-plug outer cover	1
12-11	467.5522.002.00.00	sheath	3
12-12	467.5596.001.15.00	Maintenance cover	1
12-13	467.5597.001.15.00	dipstick cover	1
12-14	0949.05014.00.07	anti-off Cross recessed pan head screw	1

FIG.13 : BASEPLATE, INVERTER, SUPPORT

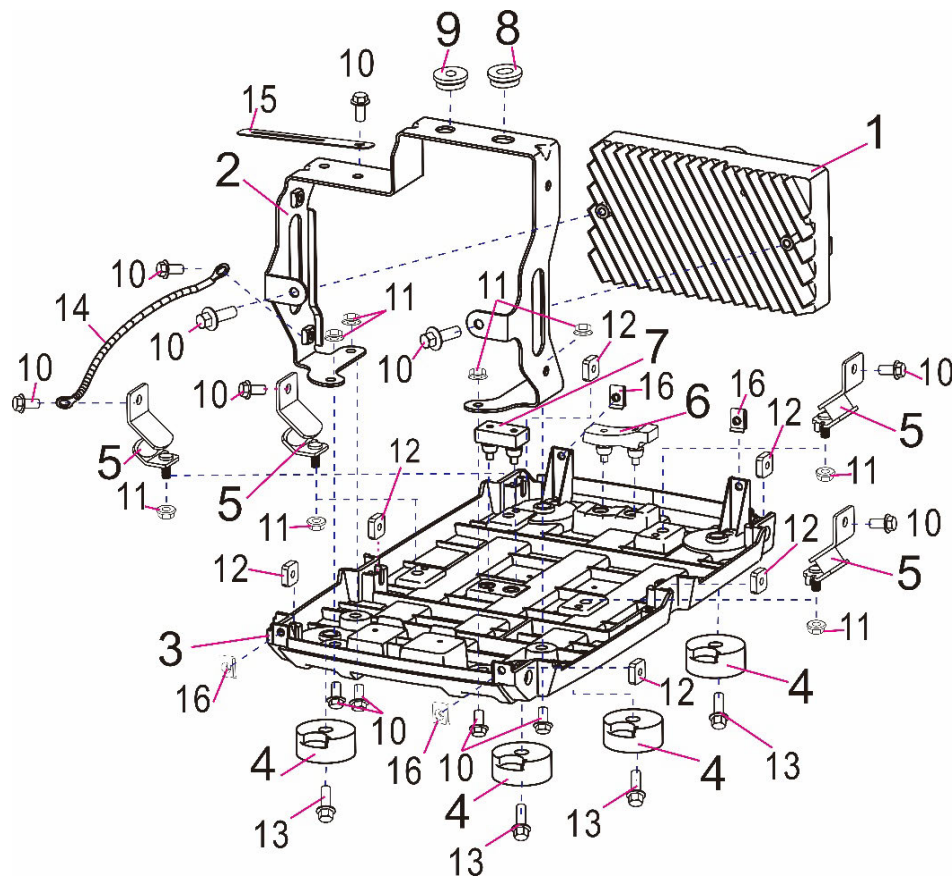

REF.NO.	PART NO	DESCRIPTION	Q'TY
13-1	467.2470.003.00.00	inverter	1
13-2	467.2471.001.00.00	steel support	1
13-3	467.3340.001.00.00	BASEPLATE	1
13-4	467.3350.001.00.00	SEAT,FRAME	4
13-5	467.3360.001.00.00	SEAT,FRAME	4
13-6	467.5523.001.00.00	Rubber bearing	1
13-7	467.5523.002.00.00	Rubber bearing	1
13-8	467.5522.002.00.00	sheath	1
13-9	467.5522.001.00.00	sheath	1
13-10	5787.06012.00.01	BOLT	12
13-11	6177.06000.00.01	NUT	8
13-12	467.5926.001.00.00	NUT	6
13-13	5789.06016.00.01	BOLT	4
13-14	467.3410.003.00.00	Ground wire	1
13-15	188.1220.002.00.00	cable clamp	1
13-16	6178.05000.00.04	NUT	4

FIG.14 CONTROL,ASSY.

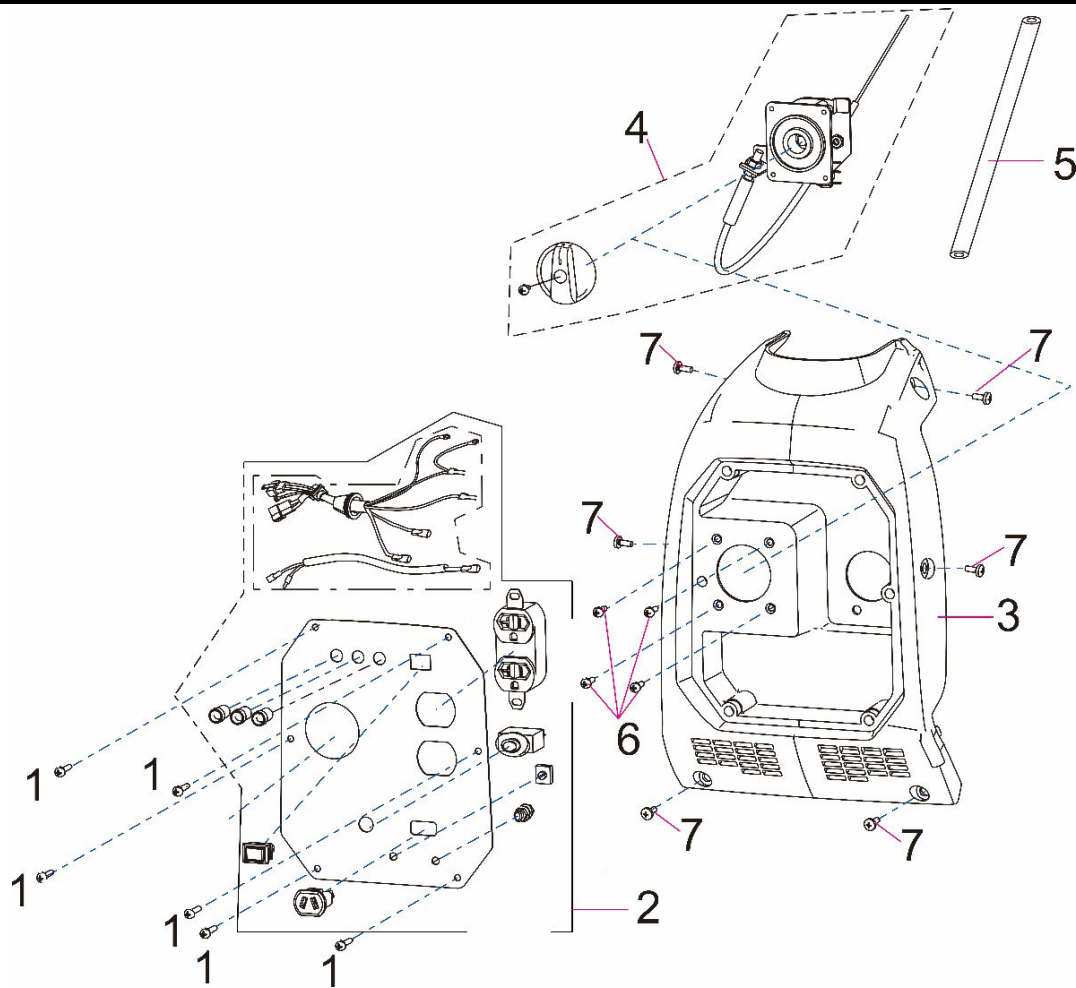

REF.NO.	PART NO	DESCRIPTION	Q'TY
14-1	0818.05016.00.07	Cross recessed pan head screw	6
14-2	467.3370.006.00.00	PANEL, CONTROL,ASSY.	1
14-3	467.6655.002.00.00	panel bed	1
14-4	467.2140.001.00.00	triangle Switch combination	1
14-5	467.2332.002.00.00	PVC fiberglass tube	1
14-6	0819.04212.00.01	sheetmetal screws	4
14-7	0818.05016.00.07	Cross recessed pan head screw	6

FIG.15 ROTOR/STATOR

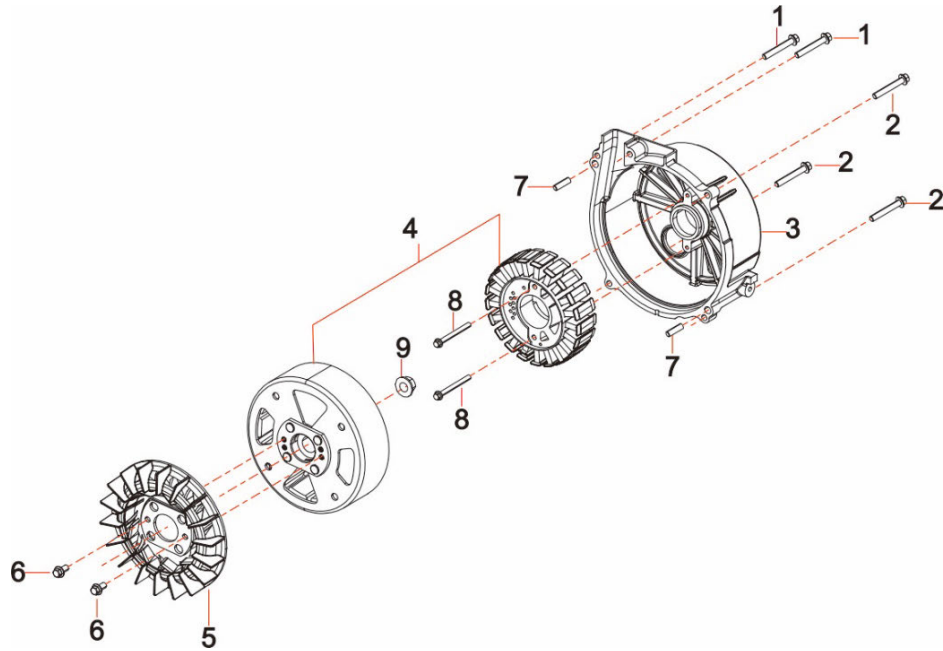

REF.NO.	PART NO	DESCRIPTION	Q'TY
15-1	5789.06030.00.01	BOLT	5
15-2	5789.06025.00.01	SHROUD, MOTOR	1
15-3	467.4060.001.00.00	STATOR COMP	1
15-4	467.4000.002.00.00	ROTOR COMP	1
15-5	148.2030.001.63.00	FAN BLADE	1
15-6	5789.06012.00.01	BOLT	2
15-7	188.3170.001.00.00	PIN	2
15-8	5789.05035.00.01	BOLT	2
15-9	6177.12000.05.01	NUT	1