

Commercial Electric's Panels are commercial luminaires utilizing an advanced LED optical system to deliver superior lighting performance. They achieve high uniformity, DLC PREMIUM energy efficiency and reduced glare in typical T-bar grid ceiling applications.

Our state-of-the-art backlit LED technology utilizes PMMA lensing over the LEDs which will not discolor over time. The need for a light guide is eliminated, thus increasing photometric performance while keeping costs competitive. Combined with the rigid back enclosure that prevents warping in application, this luminaire is designed for worry-free longevity and reliability. Available with factory installed battery backup for 90 minutes emergency egress illumination.

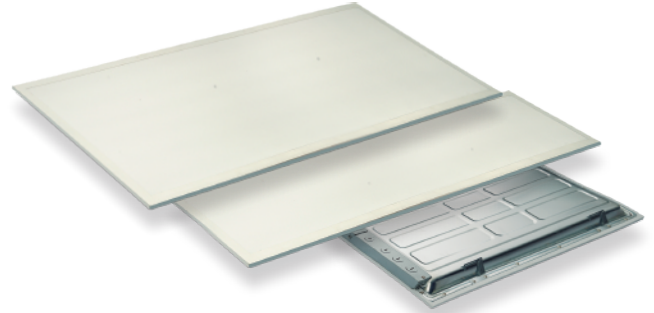

SPECIFICATIONS

CONSTRUCTION

- Aluminum frame in white finish, steel die-formed back enclosure

OPTICS

- PMMA lenses over LEDs, PS diffuser
- SDCM < 5
- UGR < 22
- 120° Beam angle

ELECTRICAL

- 0-10VDC Dimming (10%-100%)

INSTALLATION

- Recessed in T-bar grid ceiling with integral earthquake clips for secure attachment
- Surface mount and suspension mount cable kit accessories available

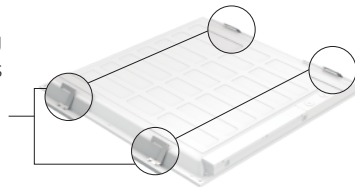

WARRANTY

- 5 Year

PHOTOMETRY

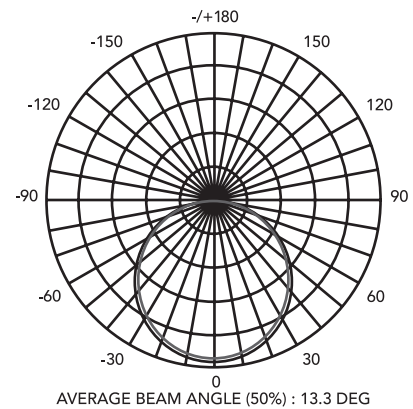

LAMBERTIAN

CERTIFICATIONS

- UL Listed for Damp Locations
- IC Rated for insulated ceilings
- RoHS, FCC
- DLC PREMIUM
- -20°C to 43°C (4°F to 110°F)

DIMENSIONS

1x4

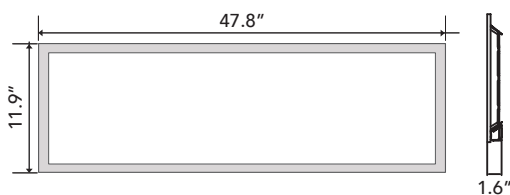

2x2

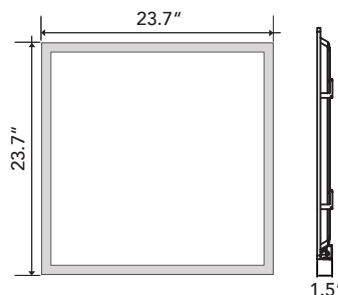

2x4

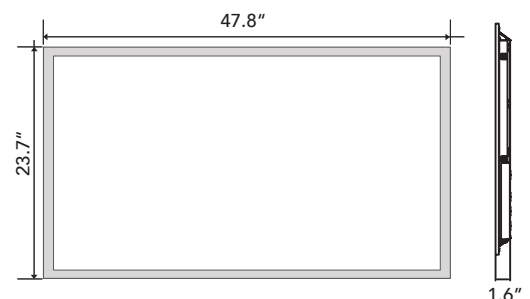

STOCKED MODELS

Catalog #	Size	CCT	Nominal Lumens	Watts	LPW	CRI	Voltage	DLC	Weight	Qty/ Carton
BLP-14-U-P-30-35K-80-D	1' x 4'	3500K	3750	30	125	80	120-277VAC	PREMIUM	5.2 lbs	2
BLP-14-U-P-30-40K-80-D	1' x 4'	4000K	3825	30	127.5	80	120-277VAC	PREMIUM	5.2 lbs	2
BLP-22-U-P-30-35K-80-D	2' x 2'	3500K	3750	30	125	80	120-277VAC	PREMIUM	5.2 lbs	2
BLP-22-U-P-30-40K-80-D	2' x 2'	4000K	3825	30	127.5	80	120-277VAC	PREMIUM	5.2 lbs	2
BLP-22-U-P-30-50K-80-D	2' x 2'	5000K	3825	30	127.5	80	120-277VAC	PREMIUM	5.2 lbs	2
BLP-22-U-P-36-35K-80-D	2' x 2'	3500K	4500	36	125	80	120-277VAC	PREMIUM	5.2 lbs	2
BLP-22-U-P-36-40K-80-D	2' x 2'	4000K	4590	36	127.5	80	120-277VAC	PREMIUM	5.2 lbs	2
BLP-22-U-P-36-50K-80-D	2' x 2'	5000K	4590	36	127.5	80	120-277VAC	PREMIUM	5.2 lbs	2
BLP-24-U-P-40-35K-80-D	2' x 4'	3500K	5000	40	125	80	120-277VAC	PREMIUM	9.2 lbs	2
BLP-24-U-P-40-40K-80-D	2' x 4'	4000K	5100	40	127.5	80	120-277VAC	PREMIUM	9.2 lbs	2
BLP-24-U-P-40-50K-80-D	2' x 4'	5000K	5100	40	127.5	80	120-277VAC	PREMIUM	9.2 lbs	2
BLP-24-U-P-50-35K-80-D	2' x 4'	3500K	6250	50	125	80	120-277VAC	PREMIUM	9.2 lbs	2
BLP-24-U-P-50-40K-80-D	2' x 4'	4000K	6375	50	127.5	80	120-277VAC	PREMIUM	9.2 lbs	2
BLP-24-U-P-50-50K-80-D	2' x 4'	5000K	6375	50	127.5	80	120-277VAC	PREMIUM	9.2 lbs	2

MOUNTING ACCESSORIES

SURFACE MOUNT KITS

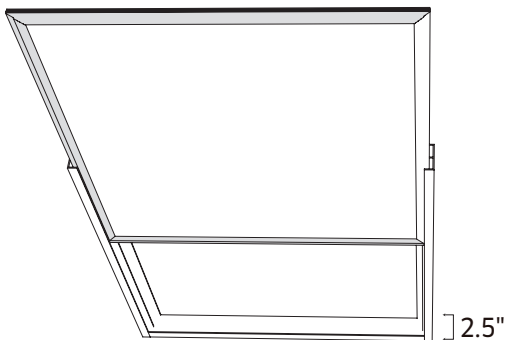

BLP-SMF-14-W

1x4 Surface Mount Kit, White

BLP-SMF-22-W

2x2 Surface Mount Kit, White

BLP-SMF-24-W

2x4 Surface Mount Kit, White

