

# INSTALLATION INSTRUCTIONS

## (FVIR) Atmospheric White-Rodgers Combination Control Replacement Kit

Read these instructions thoroughly and understand all steps and procedures before proceeding with the installation.

### INSPECT SHIPMENT:

Inspect contents for possible missing or damaged components. See Figure 1. This kit includes:

Qty. 1 (one) - Combination Gas Control

Qty. 1 (one) - Installation Instructions

### TOOLS REQUIRED:

3/8" Open-end wrench

7/16" Open-end wrench

3/4" Open-end wrench

Pipe Wrench

Soap and water solution

Pipe Thread Sealant



(Certified for use with Natural and LP Gas/Liquefied Petroleum Gases)

**NOTICE:** Compounds used on threaded joints of gas piping shall be resistant to the action of Liquefied Petroleum Gases.

### ADDITIONAL INSTRUCTIONS:

Refer to the Use and Care Manual supplied with the water heater for complete information on the installation, lighting instructions, operation and maintenance of the water heater.

## 1. TURNING OFF GAS SUPPLY TO THE WATER HEATER:

Set the thermostat dial to the lowest setting "PILOT LIGHTING" by rotating the thermostat dial on the water heater's combination gas control clockwise  until it stops. Rotate the gas control knob on the combination gas control clockwise  to the "Pilot" position and then slightly depress the gas control knob and rotate it clockwise  to the "OFF" position.

**NOTICE:** Knob cannot be turned from "PILOT" position unless pushed down slightly. Do not use force.

Shut off the gas supply at the main gas supply line. Refer to the lighting instruction label located above the water heaters combination gas control and the Use and Care manual supplied with the water heater for additional information on shutting off the gas supply.

- 2. DRAINING THE WATER HEATER:** Shut off the inlet water supply to the water heater. Connect a garden hose to the drain valve and route to a drain or suitable draining area. Open a hot water faucet to allow air to flow into the water heater tank and open the drain valve. See Figure 2.

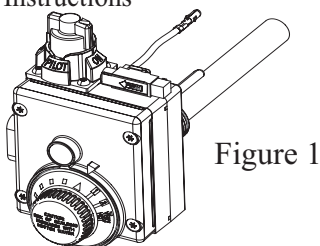

Figure 1

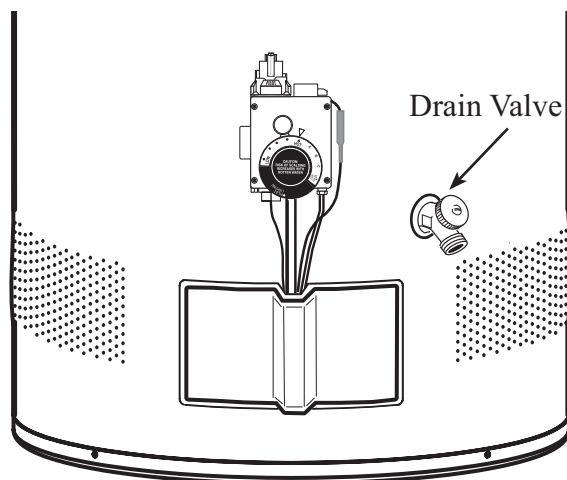

Figure 2

## 3. DISCONNECTION OF THERMOCOUPLE, PILOT SUPPLY TUBE, BURNER SUPPLY TUBE AND PIEZO WIRING FROM THE COMBINATION GAS CONTROL:

Using a 3/8" open-end wrench, disconnect the thermocouple from the combination gas control. Using a 7/16" open-end wrench, disconnect the pilot supply line from the combination gas control. Using a 3/4" open-end wrench, disconnect the burner supply tube from the combination gas control. Locate the piezo wiring, slide the protective wire insulator "boot" away from the piezo generator, and then carefully pull apart the connection. See Figure 3.

**NOTICE:** LP Gas Combination Controls use left-handed threads on the burner supply tube nut.

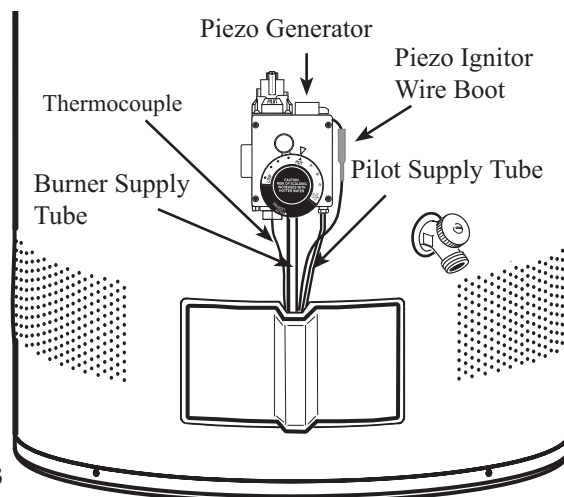

Figure 3

#### 4. COMBINATION GAS CONTROL REMOVAL:

With the gas supply shut off, disconnect the main gas supply piping from the combination gas control. After the water heater is completely drained, screw a suitable length of 1/2" NPT pipe into the gas inlet connection of the combination gas control. Rotate the control counter clockwise  $\cup$  until removed. Remove the 1/2" NPT pipe. See Figure 4.

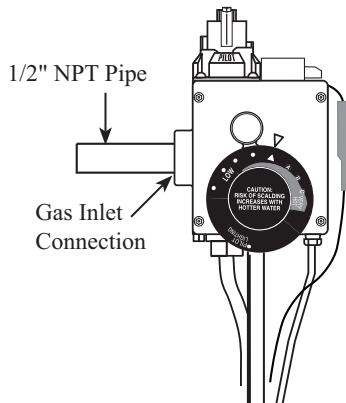

Figure 4

#### 5. NEW COMBINATION GAS CONTROL INSTALLATION:

Ensure the replacement combination gas control is correct for the gas usage of the water heater. Hand start threading the control into the water heater. Install the suitable length of 1/2" NPT pipe previously used to the gas inlet of new control. Rotate the control by turning clockwise  $\cup$  until the control is tight and in the upright position. Remove the 1/2" NPT pipe.

#### 6. CONNECTION OF THERMOCOUPLE, PILOT SUPPLY TUBE, BURNER SUPPLY TUBE AND PIEZO WIRING TO THE COMBINATION GAS CONTROL:

Install the inverted flare end of the burner supply tube into the combination gas control. Hand thread the hex nut fitting on the burner supply tube into the control. Ensure that the fitting is properly aligned with the control, otherwise cross threading of the connection will occur. Tighten the fitting using a 3/4" open-end wrench. See Figure 5.

**NOTICE:** LP Gas Combination Controls use left-handed threads on the burner supply tube nut.

Install the end of the pilot supply tube into the combination gas control. Hand thread the hex nut fitting on the pilot supply tube into the control. Ensure that the fitting is properly aligned with the control, otherwise cross threading of the connection will occur. Tighten the fitting using a 7/16" open-end wrench. See Figure 5.

Install the end of the thermocouple into the combination gas control. Hand thread the hex nut fitting on the thermocouple into the combination gas control. Ensure that the fitting is properly aligned with the control, otherwise cross threading of the connection will occur. Tighten the fitting with a 3/8" Open-end wrench. See Figure 5.

Locate the wire coming from the piezo generator and the wire out of the burner access door. Push the wire connectors together and slide the protective wire insulator "boot" over the connection. See Figure 5.

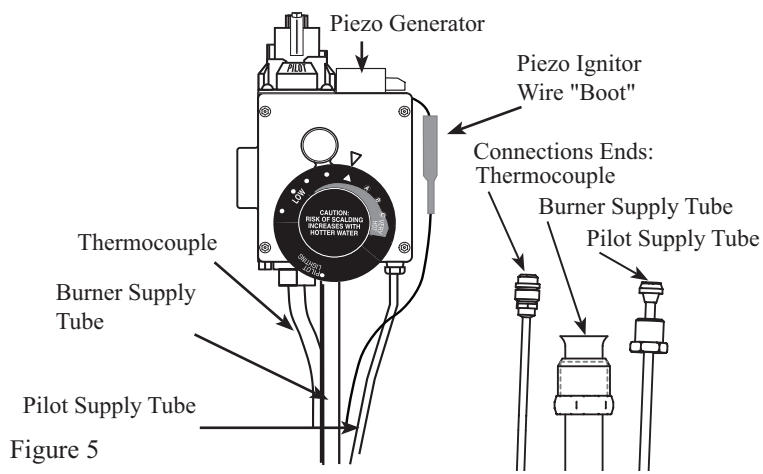

Figure 5

#### 7. CONNECTION OF THE MAIN GAS SUPPLY TO THE COMBINATION GAS CONTROL:

Reconnect the main gas supply piping to the combination gas control. Use pipe thread sealant certified for use with Natural and LP Gas/Liquefied Petroleum Gases.

**NOTICE:** Compounds used on threaded joints of gas piping shall be resistant to the action of Liquefied Petroleum Gases.

#### 8. REFILLING THE WATER HEATER:

Disconnect the garden hose from the water heater's drain valve. Close the drain valve and turn on the inlet water supply to the water heater. Open all hot water faucets to allow all trapped air to escape. Let the water heater fill until a steady stream of water is observed coming from all hot water faucets then close all faucets.

#### 9. TURN ON GAS TO THE WATER HEATER:

Turn on the main gas supply to the water heater. Check for leaks on the inlet supply piping using a soap and water solution.

**NOTICE:** If the soap and water solution bubbles up, there is a leak and the inlet supply piping must be tightened and checked again.

#### 10. LIGHTING AND OPERATION INSTRUCTIONS:

Follow the "FOR YOUR SAFETY READ BEFORE OPERATING" and "LIGHTING INSTRUCTIONS" on the label above the combination gas control or in the Use and Care Manual supplied with the water heater:

With the pilot and main burner in operation, use a soap and water solution to check for gas leaks at the burner supply and pilot tube connections.

**NOTICE:** If the soap and water solution bubbles up, there is a leak and the fittings must be tightened and checked again.

**IMPORTANT:** If the leak(s) cannot be eliminated, turn off the gas supply to the water heater and contact the water heater manufacturer at 1-800-432-8373.

11. TEMPERATURE SETTING:

**▲DANGER: Hotter water increases the potential for Hot Water SCALDS.**

Turn the temperature dial to the desired setting. A temperature setting of 120° F (49°C) or less is recommended as a usable water temperature.

The illustration in Figure 6 details the approximate water temperature for each mark on the Gas Control Temperature Dial.

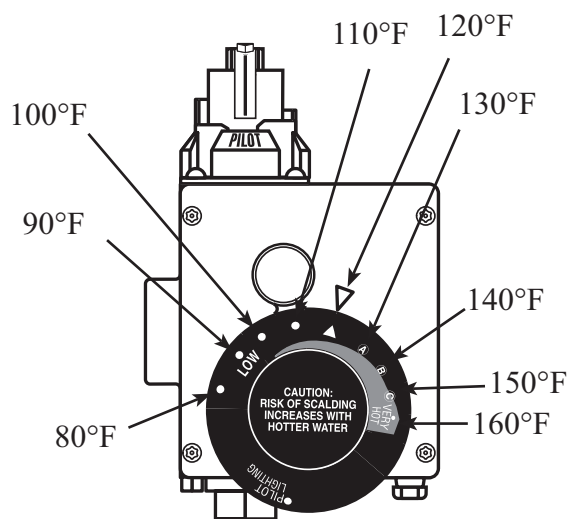

Figure 6      Temperatures are approximate

