

OPERATION



- **CAUTION!** Avoid stopping unit with flow control in “OPEN” position- material will continue to flow through hopper opening. If fertilizer is deposited too heavily in a small area, soak down thoroughly with a garden hose to prevent burning of lawn.
- **IMPORTANT:** When backing up, carefully back STRAIGHT to avoid “jack-knifing”, which can cause damage to your equipment.

WHEN TO USE

Your Aerator-Spreader should not be used when lawn conditions are too wet or too dry. This can be determined by digging a small amount of soil (about three inches deep) and checking it. If soil appears powdery and brittle - its too dry.

Wait until a later date, after a rainfall. If soil appears damp, roll it up in the palm of your hand - if it forms a ball that doesn't break up when it hits the ground, it is too wet. Wait until a later date for soil to dry some. Ideally, the soil should fall apart.

NOTE: If soil is too wet, the aerator tines will penetrate too deep and your tractor could lose traction, causing lawn damage. If soil is too dry, the aerator tines will not penetrate soil properly.

ATTACHING / TRANSPORT MODE

Attach the Aerator-Spreader to your tractor using the 1/2" Drawbar Pin and Hairpin Cotter furnished.

Pull Transport Handle towards tractor and lock it down into the transport lock.

Aerator is now in the raised position, engaging wheels. *Illustrated below.*

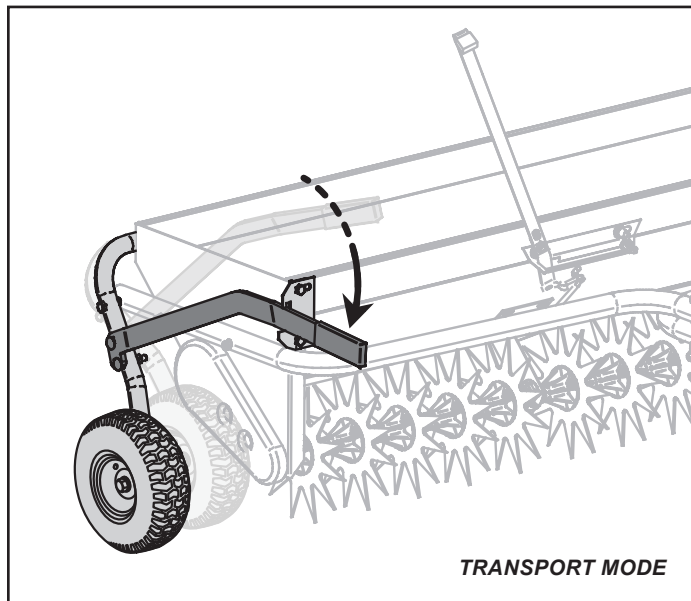
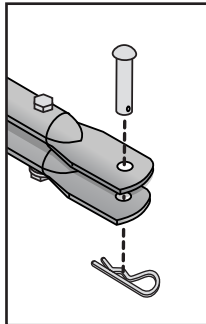

OPERATING TIPS

- Set the Flow Control to proper setting using the Nylon Wing Nut (see Alternative Flow Control Setting Chart on p.14) and move the Control Lever to closed (“0”) position.
- Fill Hopper with material to be spread at operating site.
- **CLUMPY MATERIAL** - Ensure the material is free of clumps for optimal use.

The recommended operating speed is slightly faster than a brisk walk- 3 to 5 MPH. Set the throttle/gear selector to obtain this speed. To obtain this speed Calibrate your tractor to 3 M.P.H. by:

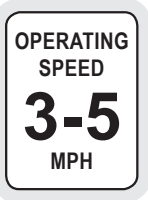

- Measure a distance of 20 feet on flat, level surface. Adjust tractor throttle and select a gear to cover this distance in 4.5 seconds. To adjust for 4 m.p.h., cover same distance in 3.4 seconds.
- Drive tractor/mower forward as you open the flow control with the Control Lever.

IN-USE MODE

After arriving at the location of property that needs aeration, release the Transport Handle. Aerator is now in the lowered position, engaging spikes. *Illustrated below.*

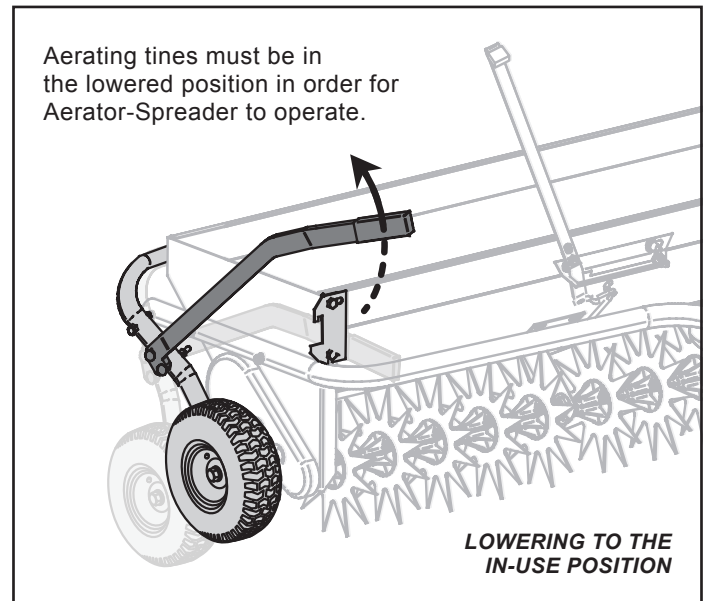

OPERATION

FLOW CONTROL ADJUSTMENT

OPEN & CLOSE: The material flow is shut off by moving Control Lever to the left and locking into “V” notch on calibration plate.

FLOW SETTING: To set the flow rate, put the Control Lever in the shut-off position (in “V” notch). Determine your required number setting as described below. Loosen the nylon wing nut and slide to the desired number setting and retighten the wing nut. Release the control strap and it will open to the pre-set position.

DETERMINING FLOW CONTROL SETTING NUMBER:

NOTE: Fertilizer application rates as described are affected by humidity and the moisture content of the material; therefore, minor setting adjustments may be necessary to compensate for these conditions.

APPLICATION RATES

Material Type	Average Usage Recommended	Flow Control Setting
Seeds:		
Ky. Bluegrass	1 lb / 1000 sq. ft.	4
Rye	2 lb / 1000 sq. ft.	7
Tall Lawn & #31 Fescue . . .	3 lb / 1000 sq. ft.	12
Fertilizer:		
Lawn Food (33-3-10) . . .	3.2 lb / 1000 sq. ft.	5-1/4
Weed & Feed (33-3-5) . .	3.2 lb / 1000 sq. ft.	5-1/4

ALTERNATIVE FLOW CONTROL SETTINGS:

To determine the required setting for materials not listed on the Application Rate Chart, proceed as follows:

Determine the amount of material to be spread over a designated area. (Noted on the material bag).

Example: “The contents of this bag (25 lbs.) will cover 5000 square feet.”

Determine the amount of material required to cover 100 square feet as follows:
Add two zeros to bag weight.

Example: 2500

Divide this number by the number of square feet on the bag.

Example: 2500 divided by 5000 = 0.5 pounds of material for 100 square feet.

NOTE: To convert this weight to ounces, simply multiply by 16 (16 oz. / lb). Example: 0.5 lb. x 16 = 8 oz.

FLOW CONTROL SETTING

Determine approximate flow control setting by using the chart below showing type of material to spread.

Measure off a distance of 40 feet in your yard. This is the distance your 30” spreader must travel in order to cover 100 square feet. (2.5 ft. (30”) x 40 ft. = 100 sq ft.) For 40” spreader measure off a distance of 30 feet in your yard, the distance to cover 100 square feet. (3.33 ft. (40”) x 30 ft. = 100 sq ft.)

Set the spreader flow control at the approximate flow control setting.

Place 5 pounds of material in the Hopper. Weigh the material before and after spreading 100 square feet to determine amount of material used.

Move unit to measure area, lower aerator tines, open Flow Control Lever. Drive the 40 ft. course, stop unit and close Flow Control Lever.

Remove and weigh remaining material. Subtract this weight from 5 pounds to determine material used: If too much material is used: Set Flow Control ONE number LOWER and try again. If too little material is used: Set Flow Control ONE number HIGHER and try again.

After determining proper setting always record the type of material and the setting for future use.

ALTERNATIVE FLOW CONTROL SETTING CHART

	Material Coarseness	Approx. Coverage		Approx. Flow Control Setting
		Wt.	Sq. Ft. Cov.	
FERTILIZER:	Very Coarse (Large, heavy pellets and grain)	0.5 lb.	100	9
		1.0 lb.	100	12
		1.5 lb.	100	15
	Medium Coarse (Pellets & granules)	0.5 lb.	100	7
		1.0 lb.	100	10
		1.5 lb.	100	13
	Light Material (Nitrogen, etc.)	0.1 lb.	100	3.5
		0.2 lb.	100	4.5
		0.3 lb.	100	5.5
SEEDS:	Large (Ky. 31 Fescue, etc.)	0.3 lb.	100	12
		0.5 lb.	100	16
		0.7 lb.	100	19
	Medium (Rye, etc.)	0.2 lb.	100	7
		0.4 lb.	100	11
		0.6 lb.	100	14
	Fine (Blugrass, Lawn Fescue, etc.)	0.1 lb.	100	4
		0.2 lb.	100	4.5
		0.3 lb.	100	5

ACCESSORIES, MAINTENANCE AND SERVICE

ACCESSORIES

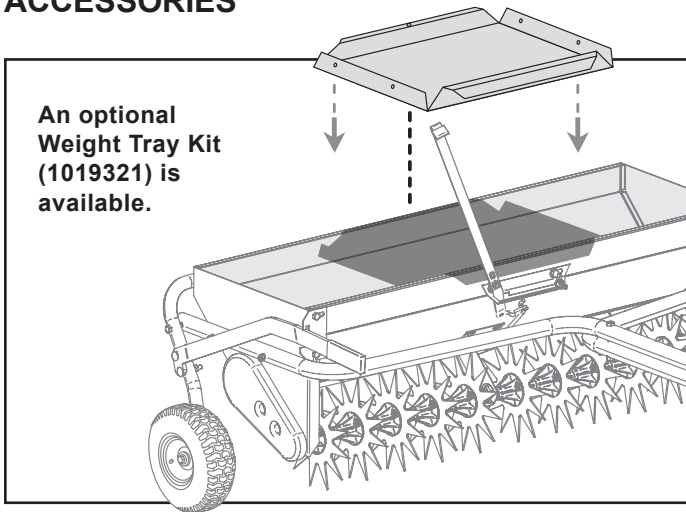

For tougher ground conditions (or to aerate without spreading), an optional weight tray can be added to the Aerator.

After installation, additional weight can then be centered on the tray and secured with bungee cords.

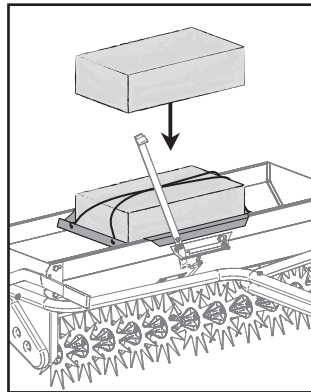

MAINTENANCE

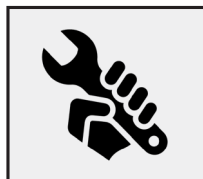

- Should rust appear on any other part of your Aerator-Spreader, sand lightly to remove rust and coat lightly with enamel.
- Apply a drop of lubricating oil to each nylon bearing (aerator tine shaft, agitator shaft, and wheels) before each use.
- Be sure to remove all unused fertilizers from hopper immediately after use and clean with water.
- To prevent rust in aerator tines, apply a light coat of oil on the working areas of tines after each use.
- After each use, service unit as described and store in a dry area, shielding tines to avoid injury.

SERVICE

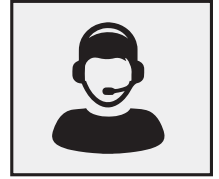

QUALITY CONTINUES WITH QUALITY SERVICE

If you have installation questions, are missing parts or need replacement parts, don't go back to the store!

Please find your product serial number and model number, then contact our Customer Service department:



In North America and Canada call
Toll-Free: **877-728-8224**



Chat online: **www.brinly.com**



Email: **customerservice@brinly.com**

ONLINE

AS2-40BH1-G



BRINLY.COM

Additional info and videos are available on our website. Please visit the URL above OR scan this QR code.